

400Hz Fans



#### Approvals

NATO codification

#### Life expectancy

L-10 LIFE AT 40°C:  
35 000 hours

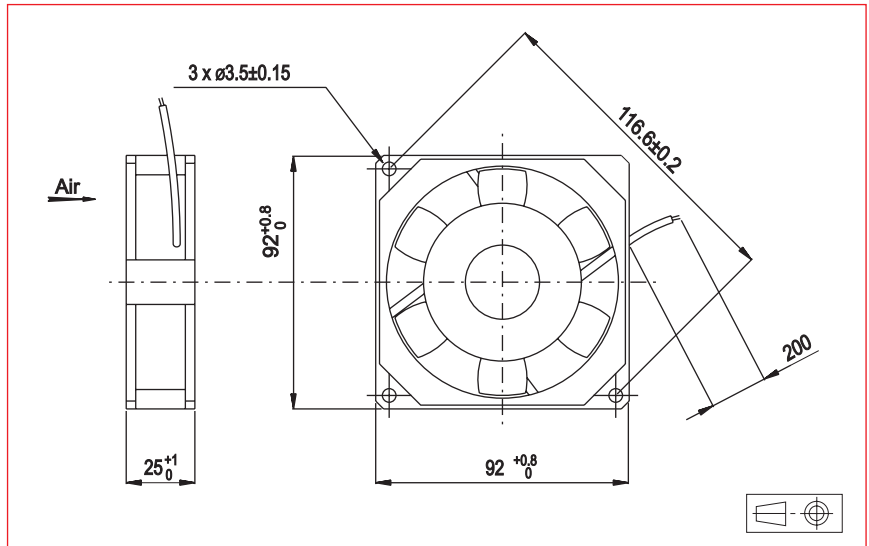

#### 400 Hz Motor

Housing material: zamak  
Impeller material: plastic UL 94 VO  
Weight: 390 g  
Bearing system: ball bearings

Connection: flying leads

Available with:  
- Speed sensor

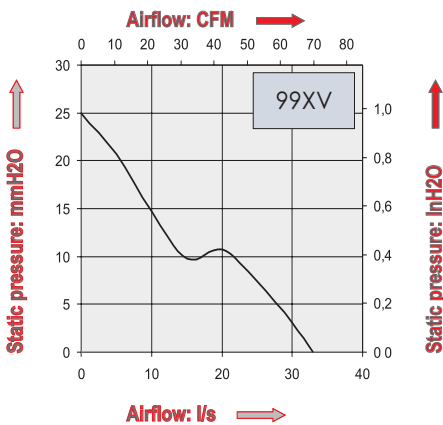

Part Number	Nominal voltage	Airflow	Noise level	Nominal speed	Phases	Capacitor (not included)	Input power	Nominal Current	Starting Current	Operating temperature	
	V	l/s	dB(A)	RPM		µF	W	mA	mA	Min. °C	Max. °C
99XV0162001	115	33	55	5500	3		14	130	280	-10	70
	115	33	55	5500	1	0,47	14	145	225	-10	70
99XV0160001	200	33	55	5500	3		14	75	160	-10	70
	200	33	55	5500	1	0,15	14	85	130	-10	70

**Additional versions:**  
Salt spray protected - Shock and vibration protected - Marine specifications  
Wide temperature range

**Accessories:**  
Refer to Accessories leaflet