

General Description

The ADT7221 is a power supply chip with 5V regulated output. It is composed of one PWM controller and one LDO regulator. It provides the pure and excellent regulated output voltage.

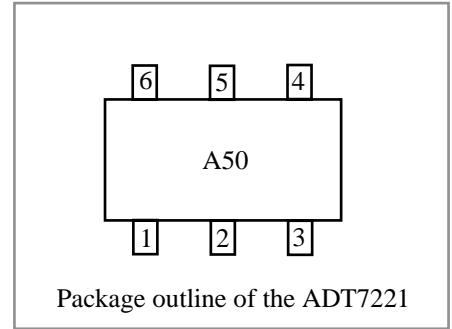

Features

- Input voltage range : 7V to 15V
- Regulated output voltage : 5V
- 350mA output load current available
- PWM controller with built-in compensation components
- Externally composed LDO pass transistor
- 500kHz fixed frequency internal oscillator
- Over voltage protection
- Small outline SOT-26 package (2.9mm x 1.6mm body)

Applications

- DC-DC Converter for 5V output
- CCD Camera module
- Navigation & Portable Devices

Typical Application Circuit

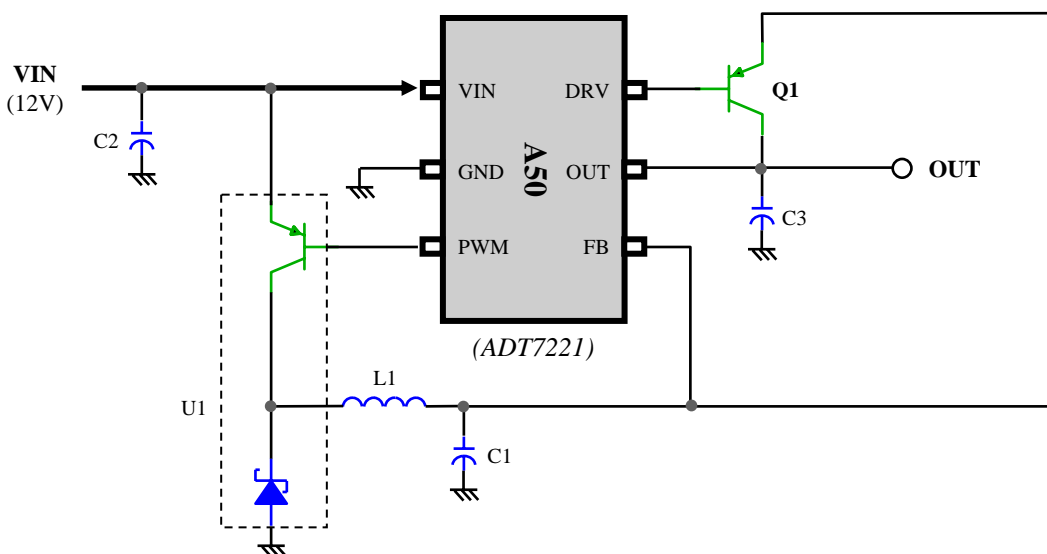

** This specifications are subject to be changed without notice*

Part List

Component	Description	Type	Value
U1*1	Composite type with a PNP transistor and schottky barrier diode	IC	FP103
Q1	PNP transistor	Chip transistor	MMBT589LT1
L1	Output filter inductor	Chip inductor	47uH/590mA
C1	Output filter capacitor	Tantalum capacitor	47uF/10V
C2	Bypass capacitor	Tantalum capacitor	10uF/25V
C3	Load capacitor for LDO	Tantalum capacitor	1uF/10V

*1 : For cost down , it is possible to use discrete component with a PNP transistor and a schottky barrier diode. In this case, you make use the discrete components with proper electrical specification. [Table A](#) shows the required key electrical limits. It is recommended to use PNP and schottky barrier diode having equivalent specification in the [Table A](#).

[Table A](#) : Selection guide for the discrete components

Component	Parameter	Ratings	Unit	Remarks
PNP	Collector to Emitter Voltage	-20	V	Recommend '2SB1424' by ROHM or Equivalent IC
	Collector Current	-2	A	
Schottky Barrier Diode	Repetitive Peak Reverse Voltage	30	V	Recommend 'RSX101M-30' by ROHM or Equivalent
	Average Rectified Current	700	mA	

Pin Configuration

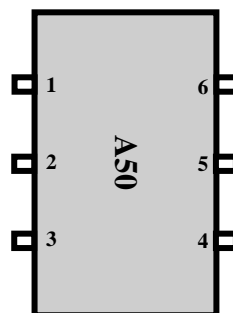

** This specifications are subject to be changed without notice*

Pin Description

Pin No.	Name	I/O	Type	Description
1	VIN	-	P	Power supply input
2	GND	-	G	Ground
3	PWM	O	D	Switching output
4	FB	I	A	Feedback voltage input
5	OUT	O	A	LDO output
6	DRV	I/O	A	LDO pass transistor drive signal

I : Input pin O : Output pin IO : Input/Output pin
 P : Power pin G : Ground pin
 A : Analog pin D : Digital pin

Functional Block Diagram

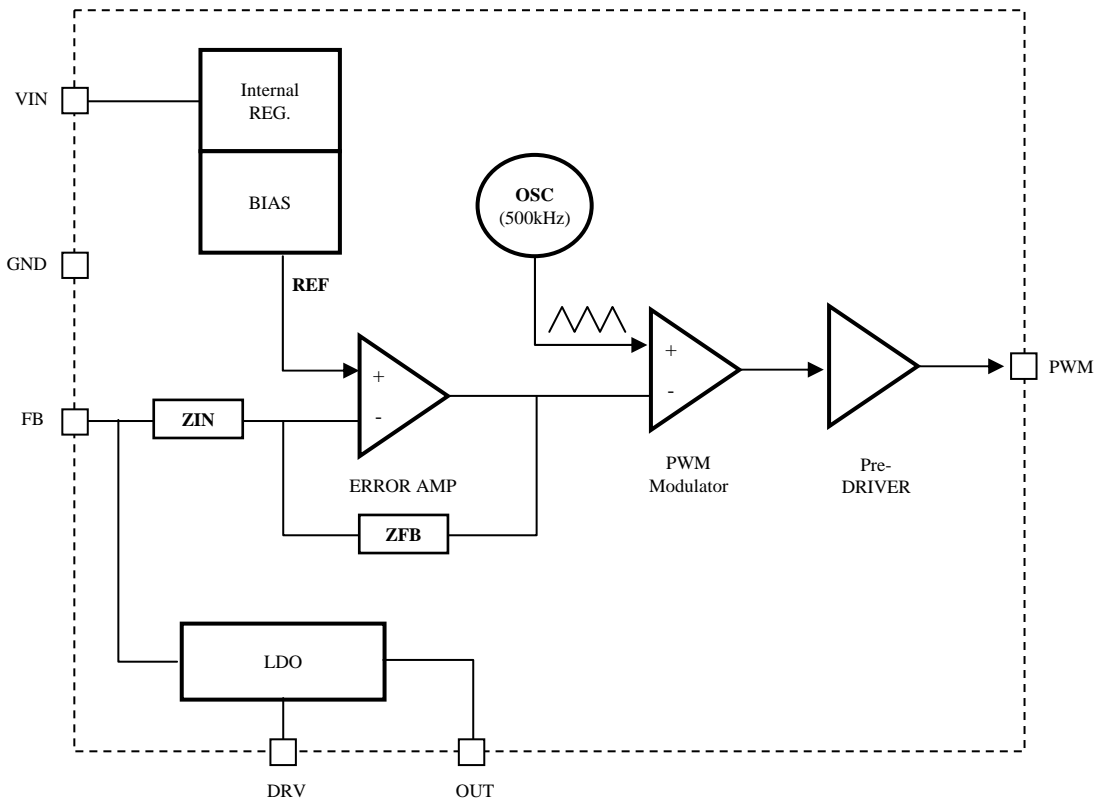

* This specifications are subject to be changed without notice

Absolute Maximum Ratings

Parameter	Symbol	Min.	Typ.	Max.	Unit
Power supply voltage	V_{IN}	-	-	23	V
Power dissipation ($T_a=70^\circ\text{C}$) (Note1)	P_{Dmax}	-	-	265	mW
Storage temperature	T_{STG}	-65	-	+150	$^\circ\text{C}$
Junction temperature	T_{Jmax}	-	-	+150	$^\circ\text{C}$
Thermal resistance	Θ_{JA}	-	301.2	-	$^\circ\text{C}/\text{W}$

Note1. derate 301 $^\circ\text{C}/\text{W}$ above +70 $^\circ\text{C}$.

Stresses beyond those listed under “Absolute Maximum Ratings” may cause permanent damage to the device. These are stress ratings only, and functional operation of the device at these or any other conditions beyond those indicated in the operational sections of the specifications is not implied. Exposure to absolute maximum rating conditions for extended periods may affect device reliability.

Operating Ratings

Parameter	Symbol	Min.	Typ.	Max.	Unit
Power supply voltage*2	V_{IN}	7.0	12.0	15.0	V
Operating temperature	T_{OPR}	-20	-	+85	$^\circ\text{C}$
Junction temperature	T_J	-	-	+125	$^\circ\text{C}$
Max. power dissipation ($T_a=70^\circ\text{C}$)*1	P_D	-	-	180	mW

*1 This spec. indicates that junction temperature of the device is under 125 $^\circ\text{C}$. In specific applications, this is recommended under this power dissipation specification.

*2 Maximum V_{IN} operating range can be extended. In this case, maximum drive current is limited. For using V_{IN} over 15V, refer to the [Table B](#).

Table B : Maximum drive current as maximum V_{IN} operating voltage.

V_{IN} (V)	16	17	18	19	20	21	22
Drive current (mA)	330	310	290	270	250	230	210

Electrical Characteristics ($T_a=25^\circ\text{C}$, $V_{IN}=12\text{V}$, unless otherwise noted)

Parameter	Condition	Min.	Typ.	Max.	Unit	Note
Supply current, operating	$I_O=0\text{mA}$	-	3	-	mA	
	$I_O=300\text{mA}$	-	10	15	mA	
PWM controller						
Efficiency	$I_O=300\text{mA}$	-	77	-	%	
Oscillator frequency	-	350	500	625	kHz	
Output voltage	$I_O=300\text{mA}$ (measured at FB pin voltage)	5.25	5.5	5.75	V	
LDO						
Output voltage	$I_O=300\text{mA}$	4.75	5.0	5.25	V	
Output drive current	-	-	300	350	mA	
Load regulation	$I_O=0$ to 350mA	-	150	-	mV	
Line regulation	$V_{IN}=7\text{V}$ to 15V, $I_O=350\text{mA}$	-	20	-	mV	

* This specifications are subject to be changed without notice

Typical Performance Characteristics

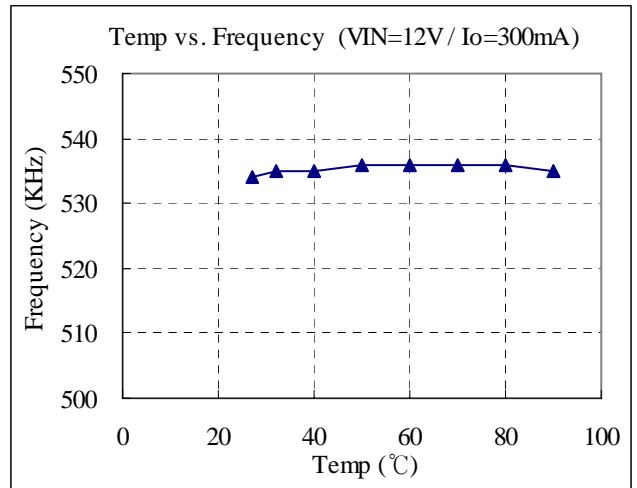
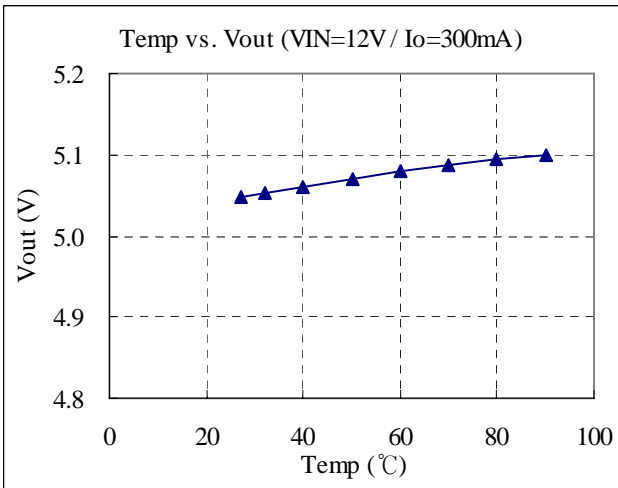
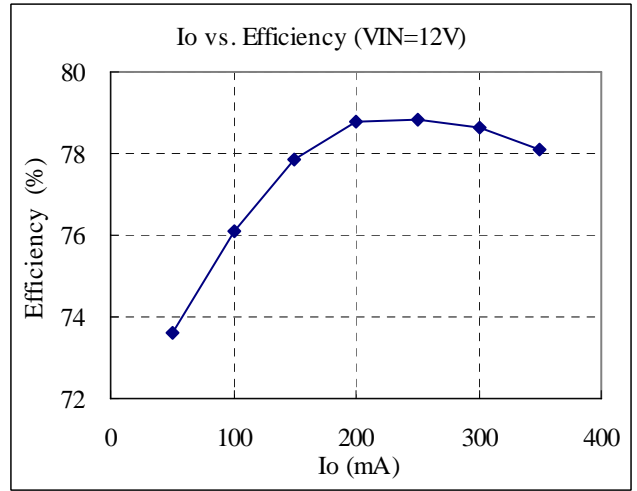
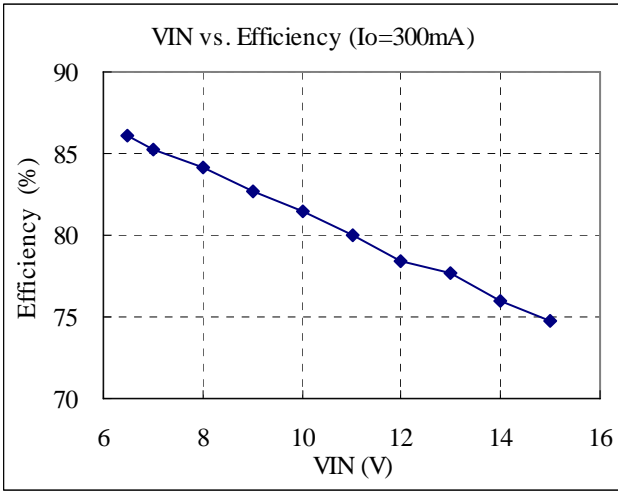

** This specifications are subject to be changed without notice*

Package ; SOT-26, 2.9mm x 1.6mm body (units : mm)

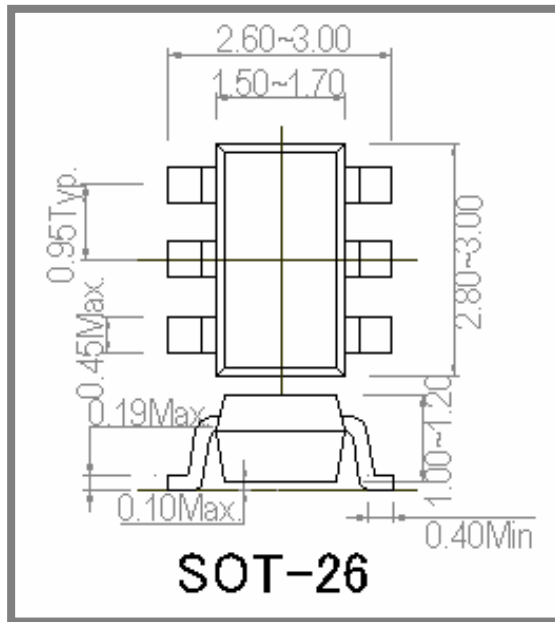

* This specifications are subject to be changed without notice