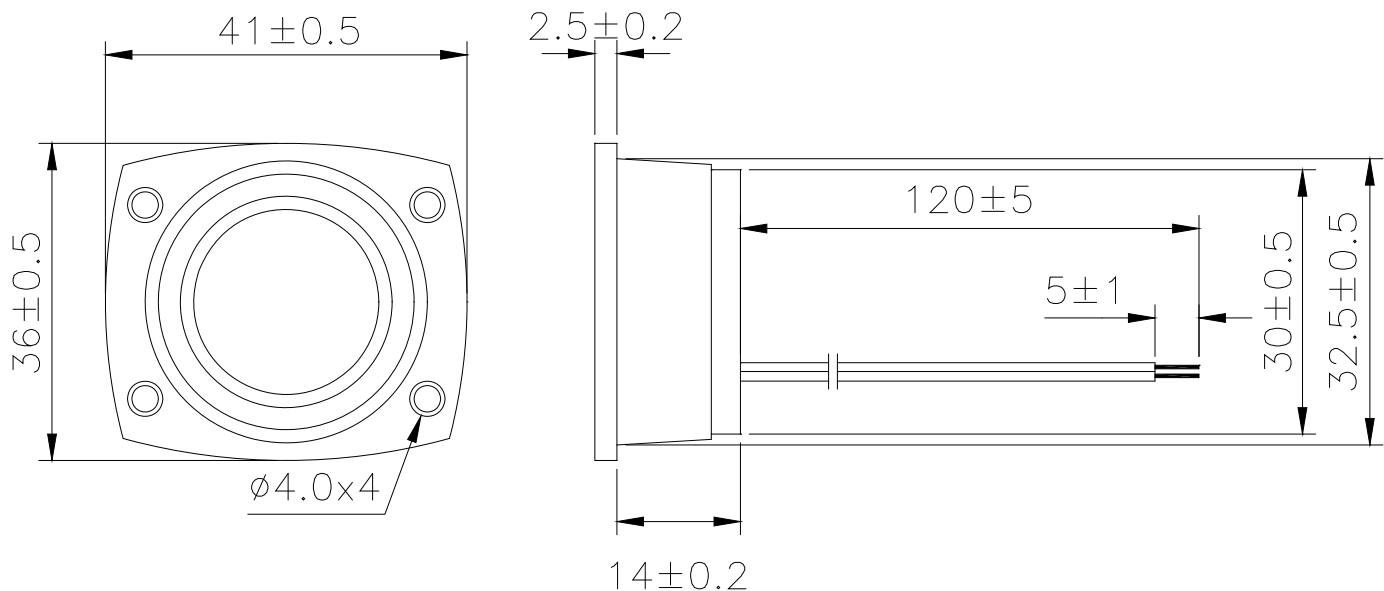

Sales Outline DrawingRevision **B****Specifications:**

Resonant Frequency (Hz)	4400 ± 500
Operating Voltage (Vp-p/max)	30
Rated Voltage (Vp-p)	5.0
Current Consumption (mA/max)	3.0 at Rated Voltage
Sound Pressure Level (dB/min)	85 at 10cm at Rated voltage
Capacitance (pF)	18,000 ±30% at 120Hz
Operating Temperature (°C)	-20 ~ +70
Storage Temperature (°C)	-30 ~ +80
Housing	ABS 757 UL94HB plastic resin (Color: Black)
Lead Wire	28 AWG
Weight (Grams)	10.2
Options	For other options contact factory

Dimensions: (units: mm)**ROHS Compliant**

Mouser Electronics

Authorized Distributor

Click to View Pricing, Inventory, Delivery & Lifecycle Information:

[Mallory Sonalert:](#)

[PT-520-SQ](#)