



## 54AC/74AC175 • 54ACT/74ACT175 Quad D Flip-Flop

### General Description

The 'AC/'ACT175 is a high-speed quad D flip-flop. The device is useful for general flip-flop requirements where clock and clear inputs are common. The information on the D inputs is stored during the LOW-to-HIGH clock transition. Both true and complemented outputs of each flip-flop are provided. A Master Reset input resets all flip-flops, independent of the Clock or D inputs, when LOW.

### Features

- $I_{CC}$  reduced by 50%
- Edge-triggered D-type inputs
- Buffered positive edge-triggered clock
- Asynchronous common reset
- True and complement output
- Outputs source/sink 24 mA
- 'ACT175 has TTL-compatible inputs
- Standard Military Drawing (SMD)
  - 'AC175: 5962-89552
  - 'ACT175: 5962-89693

**Ordering Code:** See Section 8

### Logic Symbols

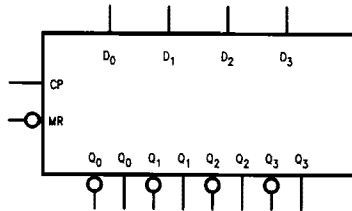

TL/F/9936-1

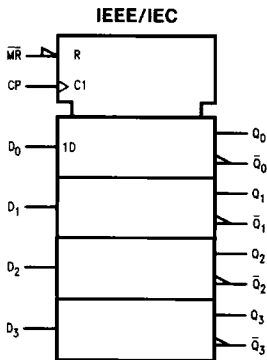

TL/F/9936-2

### Connection Diagrams

#### Pin Assignment for DIP, Flatpak and SOIC

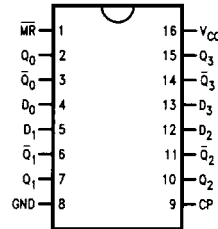

TL/F/9936-3

#### Pin Assignment for LCC

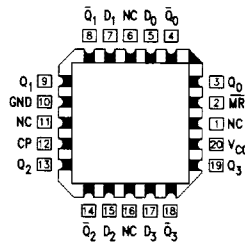

TL/F/9936-4

Pin Names	Description
D <sub>0</sub> -D <sub>3</sub>	Data Inputs
CP	Clock Pulse Input
$\overline{MR}$	Master Reset Input
Q <sub>0</sub> -Q <sub>3</sub>	True Outputs
$\overline{Q}_0$ - $\overline{Q}_3$	Complement Outputs

## Functional Description

The 'AC/ACT175 consists of four edge-triggered D flip-flops with individual D inputs and Q and  $\bar{Q}$  outputs. The Clock and Master Reset are common. The four flip-flops will store the state of their individual D inputs on the LOW-to-HIGH clock (CP) transition, causing individual Q and  $\bar{Q}$  outputs to follow. A LOW input on the Master Reset ( $\bar{MR}$ ) will force all Q outputs LOW and  $\bar{Q}$  outputs HIGH independent of Clock or Data inputs. The 'AC/ACT175 is useful for general logic applications where a common Master Reset and Clock are acceptable.

## Truth Table

Inputs		Outputs	
@ $t_n$ , $\bar{MR} = H$		@ $t_{n+1}$	
$D_n$		$Q_n$	$\bar{Q}_n$
L		L	H
H		H	L

H = HIGH Voltage Level  
 L = LOW Voltage Level  
 $t_n$  = Bit Time before Clock Pulse  
 $t_{n+1}$  = Bit Time after Clock Pulse

## Logic Diagram

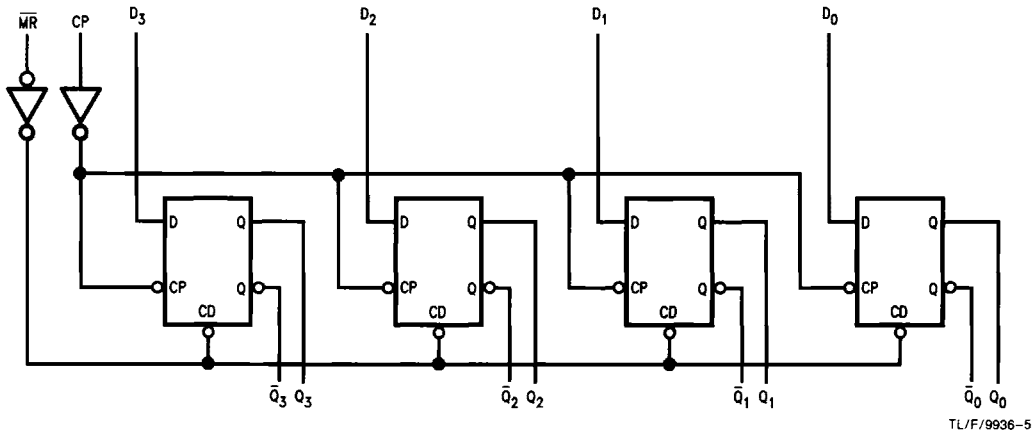

Please note that this diagram is provided only for the understanding of logic operations and should not be used to estimate propagation delays.

## Absolute Maximum Ratings (Note 1)

If Military/Aerospace specified devices are required, please contact the National Semiconductor Sales Office/Distributors for availability and specifications.

Supply Voltage ( $V_{CC}$ )	-0.5V to +7.0V
DC Input Diode Current ( $I_{IK}$ )	
$V_I = -0.5V$	-20 mA
$V_I = V_{CC} + 0.5V$	+20 mA
DC Input Voltage ( $V_I$ )	-0.5V to $V_{CC} + 0.5V$
DC Output Diode Current ( $I_{OK}$ )	
$V_O = -0.5V$	-20 mA
$V_O = V_{CC} + 0.5V$	+20 mA
DC Output Voltage ( $V_O$ )	-0.5V to $V_{CC} + 0.5V$
DC Output Source or Sink Current ( $I_O$ )	±50 mA
DC $V_{CC}$ or Ground Current per Output Pin ( $I_{CC}$ or $I_{GND}$ )	±50 mA
Storage Temperature ( $T_{STG}$ )	-65°C to +150°C
Junction Temperature ( $T_J$ )	
CDIP	175°C
PDIP	140°C

**Note 1:** Absolute maximum ratings are those values beyond which damage to the device may occur. The databook specifications should be met, without exception, to ensure that the system design is reliable over its power supply, temperature, and output/input loading variables. National does not recommend operation of FACT™ circuits outside databook specifications.

## Recommended Operating Conditions

Supply Voltage ( $V_{CC}$ )	
'AC	2.0V to 6.0V
'ACT	4.5V to 5.5V
Input Voltage ( $V_I$ )	0V to $V_{CC}$
Output Voltage ( $V_O$ )	0V to $V_{CC}$
Operating Temperature ( $T_A$ )	
74AC/ACT	-40°C to +85°C
54AC/ACT	-55°C to +125°C
Minimum Input Edge Rate ( $\Delta V/\Delta t$ )	
'AC Devices	
$V_{IN}$ from 30% to 70% of $V_{CC}$	
$V_{CC}$ @ 3.3V, 4.5V, 5.5V	125 mV/ns
Minimum Input Edge Rate ( $\Delta V/\Delta t$ )	
'ACT Devices	
$V_{IN}$ from 0.8V to 2.0V	
$V_{CC}$ @ 4.5V, 5.5V	125 mV/ns

## DC Characteristics for 'AC Family Devices

Symbol	Parameter	$V_{CC}$ (V)	74AC		54AC	74AC	Units	Conditions	
			$T_A = +25^\circ\text{C}$		$T_A = -55^\circ\text{C to } +125^\circ\text{C}$	$T_A = -40^\circ\text{C to } +85^\circ\text{C}$			
			Typ	Guaranteed Limits					
$V_{IH}$	Minimum High Level Input Voltage	3.0	1.5	2.1	2.1	2.1	V	$V_{OUT} = 0.1V$ or $V_{CC} - 0.1V$	
		4.5	2.25	3.15	3.15	3.15			
		5.5	2.75	3.85	3.85	3.85			
$V_{IL}$	Maximum Low Level Input Voltage	3.0	1.5	0.9	0.9	0.9	V	$V_{OUT} = 0.1V$ or $V_{CC} - 0.1V$	
		4.5	2.25	1.35	1.35	1.35			
		5.5	2.75	1.65	1.65	1.65			
$V_{OH}$	Minimum High Level Output Voltage	3.0	2.99	2.9	2.9	2.9	V	$I_{OUT} = -50 \mu\text{A}$	
		4.5	4.49	4.4	4.4	4.4			
		5.5	5.49	5.4	5.4	5.4			
			3.0		2.56	2.4	2.46	V	* $V_{IN} = V_{IL}$ or $V_{IH}$ -12 mA $I_{OH}$ -24 mA -24 mA
			4.5		3.86	3.7	3.76		
			5.5		4.86	4.7	4.76		
$V_{OL}$	Maximum Low Level Output Voltage	3.0	0.002	0.1	0.1	0.1	V	$I_{OUT} = 50 \mu\text{A}$	
		4.5	0.001	0.1	0.1	0.1			
		5.5	0.001	0.1	0.1	0.1			
			3.0		0.36	0.50	0.44	V	* $V_{IN} = V_{IL}$ or $V_{IH}$ 12 mA $I_{OL}$ 24 mA 24 mA
			4.5		0.36	0.50	0.44		
			5.5		0.36	0.50	0.44		
$I_{IN}$	Maximum Input Leakage Current	5.5		±0.1	±1.0	±1.0	μA	$V_I = V_{CC}, \text{GND}$	

\*All outputs loaded; thresholds on input associated with output under test.

## DC Characteristics for 'AC Family Devices (Continued)

Symbol	Parameter	V <sub>CC</sub> (V)	74AC		54AC	74AC		Units	Conditions
			T <sub>A</sub> = +25°C		T <sub>A</sub> = -55°C to +125°C	T <sub>A</sub> = -40°C to +85°C			
			Typ	Guaranteed Limits					
I <sub>OLD</sub>	†Minimum Dynamic Output Current	5.5			50	75		mA	V <sub>OLD</sub> = 1.65V Max
I <sub>OHD</sub>		5.5			-50	-75		mA	V <sub>OHD</sub> = 3.85V Min
I <sub>CC</sub>	Maximum Quiescent Supply Current	5.5		4.0	80.0	40.0		μA	V <sub>IN</sub> = V <sub>CC</sub> or GND

†Maximum test duration 2.0 ms, one output loaded at a time.

**Note:** I<sub>IN</sub> and I<sub>CC</sub> @ 3.0V are guaranteed to be less than or equal to the respective limit @ 5.5V V<sub>CC</sub>.

I<sub>CC</sub> for 54AC @ 25°C is identical to 74AC @ 25°C.

## DC Characteristics for 'ACT Family Devices

Symbol	Parameter	V <sub>CC</sub> (V)	74ACT		54ACT	74ACT		Units	Conditions
			T <sub>A</sub> = +25°C		T <sub>A</sub> = -55°C to +125°C	T <sub>A</sub> = -40°C to +85°C			
			Typ	Guaranteed Limits					
V <sub>IH</sub>	Minimum High Level Input Voltage	4.5	1.5	2.0	2.0	2.0		V	V <sub>OUT</sub> = 0.1V or V <sub>CC</sub> - 0.1V
		5.5	1.5	2.0	2.0	2.0			
V <sub>IL</sub>	Maximum Low Level Input Voltage	4.5	1.5	0.8	0.8	0.8		V	V <sub>OUT</sub> = 0.1V or V <sub>CC</sub> - 0.1V
		5.5	1.5	0.8	0.8	0.8			
V <sub>OH</sub>	Minimum High Level Output Voltage	4.5	4.49	4.4	4.4	4.4		V	I <sub>OUT</sub> = -50 μA
		5.5	5.49	5.4	5.4	5.4			
		4.5		3.86	3.70	3.76	V	*V <sub>IN</sub> = V <sub>IL</sub> or V <sub>IH</sub> -24 mA I <sub>OH</sub> -24 mA	
		5.5		4.86	4.70	4.76			
V <sub>OL</sub>	Maximum Low Level Output Voltage	4.5	0.001	0.1	0.1	0.1		V	I <sub>OUT</sub> = 50 μA
		5.5	0.001	0.1	0.1	0.1			
		4.5		0.36	0.50	0.44	V	*V <sub>IN</sub> = V <sub>IL</sub> or V <sub>IH</sub> 24 mA I <sub>OL</sub> 24 mA	
		5.5		0.36	0.50	0.44			
I <sub>IN</sub>	Maximum Input Leakage Current	5.5		±0.1	±1.0	±1.0		μA	V <sub>I</sub> = V <sub>CC</sub> , GND
I <sub>CC</sub> T	Maximum I <sub>CC</sub> /Input	5.5	0.6		1.6	1.5		mA	V <sub>I</sub> = V <sub>CC</sub> - 2.1V
I <sub>OLD</sub>	†Minimum Dynamic Output Current	5.5			50	75		mA	V <sub>OLD</sub> = 1.65V Max
I <sub>OHD</sub>		5.5			-50	-75		mA	V <sub>OHD</sub> = 3.85V Min
I <sub>CC</sub>	Maximum Quiescent Supply Current	5.5		4.0	80.0	40.0		μA	V <sub>IN</sub> = V <sub>CC</sub> or GND

\*All outputs loaded; thresholds on input associated with output under test.

†Maximum test duration 2.0 ms, one output loaded at a time.

**Note:** I<sub>CC</sub> for 54ACT @ 25°C is identical to 74ACT @ 25°C.

### AC Electrical Characteristics: See Section 2 for waveforms

Symbol	Parameter	V <sub>CC</sub> * (V)	74AC			54AC		74AC		Units	Fig. No.
			T <sub>A</sub> = +25°C C <sub>L</sub> = 50 pF			T <sub>A</sub> = -55°C to +125°C C <sub>L</sub> = 50 pF		T <sub>A</sub> = -40°C to +85°C C <sub>L</sub> = 50 pF			
			Min	Typ	Max	Min	Max	Min	Max		
f <sub>max</sub>	Maximum Clock Frequency	3.3 5.0	149 187	214 244		95 95		139 187	MHz		
t <sub>PLH</sub>	Propagation Delay CP to Q <sub>n</sub> or $\bar{Q}_n$	3.3 5.0	2.0 1.5	9.5 7.0	12.0 9.0	1.0 1.5	14.5 10.5	2.0 1.0	13.5 9.5	ns	2-3,4
t <sub>PHL</sub>	Propagation Delay CP to Q <sub>n</sub> or $\bar{Q}_n$	3.3 5.0	2.5 1.5	8.5 6.0	13.0 9.5	1.0 1.5	15.0 11.5	2.0 1.5	14.5 10.5	ns	2-3,4
t <sub>PLH</sub>	Propagation Delay $\bar{MR}$ to $\bar{Q}_n$	3.3 5.0	3.0 2.0	7.5 5.5	12.5 9.0	1.0 1.5	15.0 11.0	2.5 1.5	13.5 10.0	ns	2-3,4
t <sub>PHL</sub>	Propagation Delay $\bar{MR}$ to Q <sub>n</sub>	3.3 5.0	3.0 2.0	8.5 6.0	11.0 8.5	1.0 1.5	13.5 10.5	2.5 1.5	12.5 9.0	ns	2-3,4

\*Voltage Range 3.3 is 3.3V ± 0.3V  
Voltage Range 5.0 is 5.0V ± 0.5V

### AC Operating Requirements: See Section 2 for waveforms

Symbol	Parameter	V <sub>CC</sub> * (V)	74AC		54AC		74AC		Units	Fig. No.
			T <sub>A</sub> = +25°C C <sub>L</sub> = 50 pF		T <sub>A</sub> = -55°C to +125°C C <sub>L</sub> = 50 pF		T <sub>A</sub> = -40°C to +85°C C <sub>L</sub> = 50 pF			
			Typ	Guaranteed Minimum						
t <sub>s</sub>	Setup Time, HIGH or LOW D <sub>n</sub> to CP	3.3 5.0	2.0 1.0	4.5 3.0		5.0 3.5		4.5 3.0	ns	2-7
t <sub>h</sub>	Hold Time, HIGH or LOW D <sub>n</sub> to CP	3.3 5.0	1.0 1.0	1.0 1.0		2.0 2.5		1.0 1.0	ns	2-7
t <sub>w</sub>	CP Pulse Width HIGH or LOW	3.3 5.0	2.5 2.0	4.5 3.5		6.0 5.0		4.5 3.5	ns	2-4
t <sub>w</sub>	$\bar{MR}$ Pulse Width, LOW	3.3 5.0	2.5 2.0	4.5 3.5		5.5 5.0		5.0 3.5	ns	2-4
t <sub>rec</sub>	Recovery Time $\bar{MR}$ to CP	3.3 5.0	-2.0 -1.0	0 0		1.5 1.5		0 0	ns	2-4,7

\*Voltage Range 3.3 is 3.3V ± 0.3V  
Voltage Range 5.0 is 5.0V ± 0.5V

**AC Electrical Characteristics:** See Section 2 for waveforms

Symbol	Parameter	V <sub>CC</sub> * (V)	74ACT			54ACT		74ACT		Units	Fig. No.
			T <sub>A</sub> = +25°C C <sub>L</sub> = 50 pF			T <sub>A</sub> = -55°C to +125°C C <sub>L</sub> = 50 pF		T <sub>A</sub> = -40°C to +85°C C <sub>L</sub> = 50 pF			
			Min	Typ	Max	Min	Max	Min	Max		
f <sub>max</sub>	Maximum Clock Frequency	5.0	175	236		95		145	MHz		
t <sub>PLH</sub>	Propagation Delay CP to Q <sub>n</sub> or $\bar{Q}_n$	5.0	2.0	6.0	10.0	1.5	11.5	1.5	11.0	ns	2-3,4
t <sub>PHL</sub>	Propagation Delay CP to Q <sub>n</sub> or $\bar{Q}_n$	5.0	2.0	7.0	11.0	1.5	12.5	1.5	12.0	ns	2-3,4
t <sub>PLH</sub>	Propagation Delay MR to $\bar{Q}_n$	5.0	2.0	6.0	9.5	1.5	11.5	1.5	10.5	ns	2-3,4
t <sub>PHL</sub>	Propagation Delay MR to Q <sub>n</sub>	5.0	2.0	5.5	9.5	1.5	11.0	1.5	10.5	ns	2-3,4

\*Voltage Range 5.0 is 5.0V ± 0.5V

**AC Operating Requirements:** See Section 2 for waveforms

Symbol	Parameter	V <sub>CC</sub> * (V)	74ACT		54ACT		74ACT		Units	Fig. No.
			T <sub>A</sub> = +25°C C <sub>L</sub> = 50 pF		T <sub>A</sub> = -55°C to +125°C C <sub>L</sub> = 50 pF		T <sub>A</sub> = -40°C to +85°C C <sub>L</sub> = 50 pF			
			Typ	Guaranteed Minimum						
t <sub>s</sub> (H) t <sub>s</sub> (L)	Setup Time D <sub>n</sub> to CP	5.0	3.0	2.0	3.5	2.0	3.5	2.5	ns	2-7
t <sub>h</sub>	Hold Time, HIGH or LOW D <sub>n</sub> to CP	5.0	0	1.0	1.5	1.0			ns	2-7
t <sub>w</sub>	CP Pulse Width HIGH or LOW	5.0	4.0	3.0	5.0	3.5			ns	2-4
t <sub>w</sub>	MR Pulse Width, LOW	5.0	4.0	3.0	5.0	4.0			ns	2-4
t <sub>rec</sub>	Recovery Time, MR to CP	5.0	0	0	1.5	0			ns	2-4,7

\*Voltage Range 5.0 is 5.0V ± 0.5V

**Capacitance**

Symbol	Parameter	Typ	Units	Conditions
C <sub>IN</sub>	Input Capacitance	4.5	pF	V <sub>CC</sub> = OPEN
C <sub>PD</sub>	Power Dissipation Capacitance	45.0	pF	V <sub>CC</sub> = 5.0V