

# NPN SILICON TRANSISTOR

## 2SC2784

**DESCRIPTION** The 2SC2784 is the best for use as the middle range amplifier in Hi-Fi stereo control amplifiers, power amplifiers, and etc.

- FEATURES**
- High voltage.  $V_{CEO} : 60 \text{ V}$
  - Low output capacitance.  $C_{ob} : 1.6 \text{ pF TYP. } (V_{CB} = 30 \text{ V})$
  - High  $h_{FE}$   $h_{FE} : 600 \text{ TYP. } (V_{CE} = 6.0 \text{ V, } I_C = 1.0 \text{ mA})$
  - Super low noise.  $NV : 25 \text{ mV TYP. } (\text{See test circuit.})$
  - Complementary to the NEC 2SA1174 PNP transistor.

**ABSOLUTE MAXIMUM RATINGS ( $T_a = 25^\circ \text{C}$ )**

<b>Maximum Temperatures</b>	
Storage Temperature	-55 to +125 °C
Junction Temperature	+125 °C Maximum
<b>Maximum Power Dissipation (<math>T_a = 25^\circ \text{C}</math>)</b>	
Total Power Dissipation	300 mW
<b>Maximum Voltages and Currents</b>	
$V_{CBO}$ Collector to Base Voltage	60 V
$V_{CEO}$ Collector to Emitter Voltage	60 V
$V_{EBO}$ Emitter to Base Voltage	5.0 V
$I_C$ Collector Current	50 mA
$I_B$ Base Current	10 mA

**PACKAGE DIMENSIONS**  
in millimeters

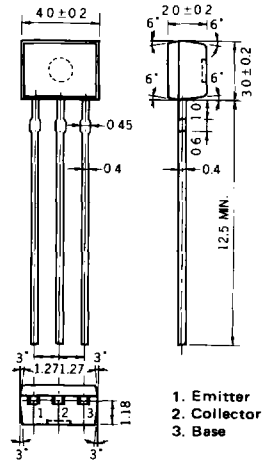

**ELECTRICAL CHARACTERISTICS ( $T_a = 25^\circ \text{C}$ )**

SYMBOL	CHARACTERISTIC	MIN.	TYP.	MAX.	UNIT	TEST CONDITIONS
$h_{FE1}$	DC Current Gain	150	580		—	$V_{CE}=6.0 \text{ V, } I_C=0.1 \text{ mA}$
$h_{FE2}$	DC Current Gain	200	600	1200	—	$V_{CE}=6.0 \text{ V, } I_C=1.0 \text{ mA}$
$f_T$	Gain Bandwidth Product	50	110		MHz	$V_{CE}=6.0 \text{ V, } I_C=1.0 \text{ mA}$
$C_{ob}$	Output Capacitance		1.6	2.5	pF	$V_{CB}=30 \text{ V, } I_E=0, f=1.0 \text{ MHz}$
NV	Noise Voltage		25	40	mV	$V_{CE}=5.0 \text{ V, } I_C=1.0 \text{ mA, } R_G=100 \text{ k}\Omega$ $G_V=80 \text{ dB, } f=10 \text{ Hz to } 1.0 \text{ kHz}$
$I_{CBO}$	Collector Cutoff Current			50	nA	$V_{CB}=60 \text{ V, } I_E=0$
$I_{CEO}$	Collector Cutoff Current		1.0		$\mu\text{A}$	$V_{CE}=60 \text{ V, } R_{BE}=\infty$
$I_{EBO}$	Emitter Cutoff Current		50		nA	$V_{EB}=5.0 \text{ V, } I_C=0$
$V_{BE}$	Base to Emitter Voltage	0.55	0.59	0.65	V	$V_{CE}=6.0 \text{ V, } I_C=1.0 \text{ mA}$
$V_{CE(sat)}$	Collector Saturation Voltage		0.07	0.30	V	$I_C=10 \text{ mA, } I_B=1.0 \text{ mA}$

Classification of  $h_{FE2}$

Rank	P	F	E	U
Range	200 - 400	300 - 600	400 - 800	600 - 1200

$h_{FE2}$  Test Conditions :  $V_{CE} = 6.0 \text{ V, } I_C = 1.0 \text{ mA}$

TYPICAL CHARACTERISTICS (Ta = 25 °C unless otherwise noted)

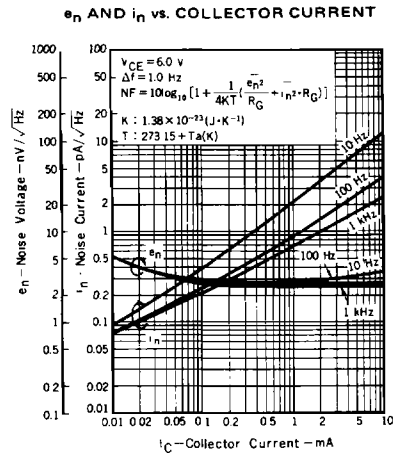
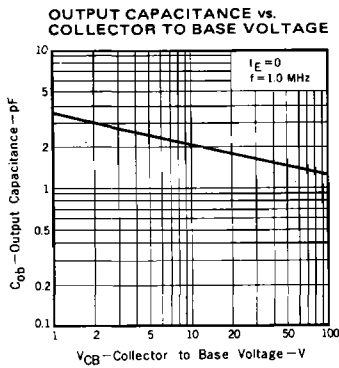
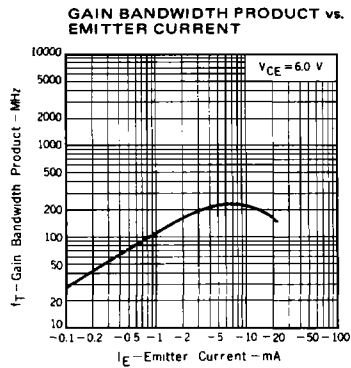
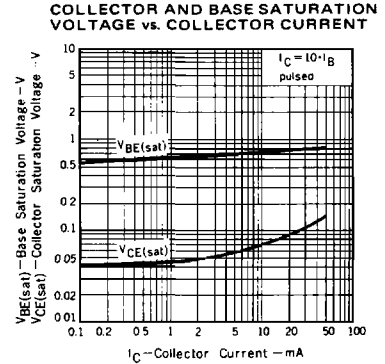
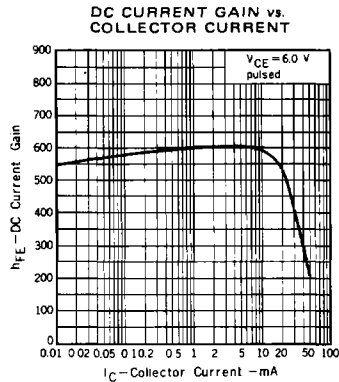
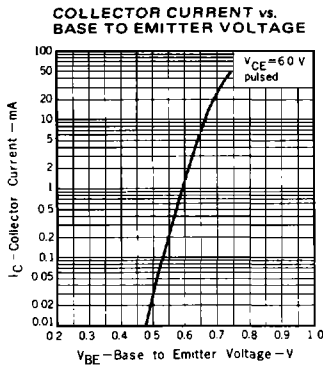
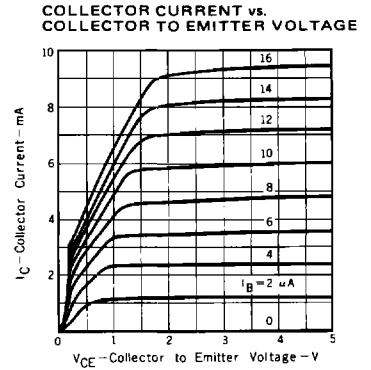
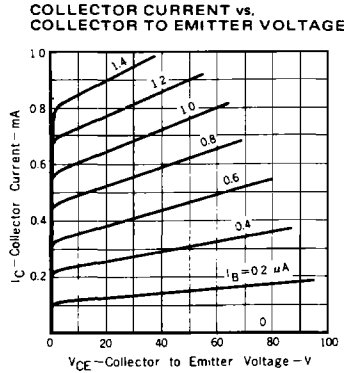
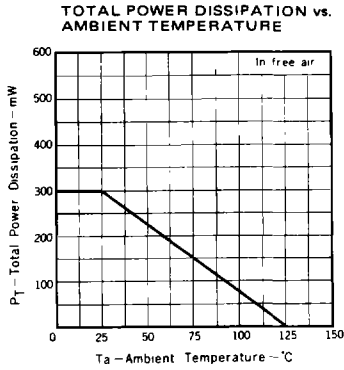

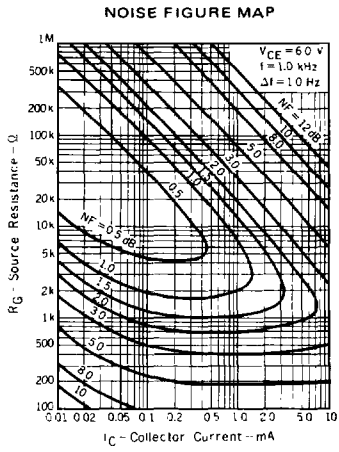

**NOISE VOLTAGE TEST CIRCUIT**

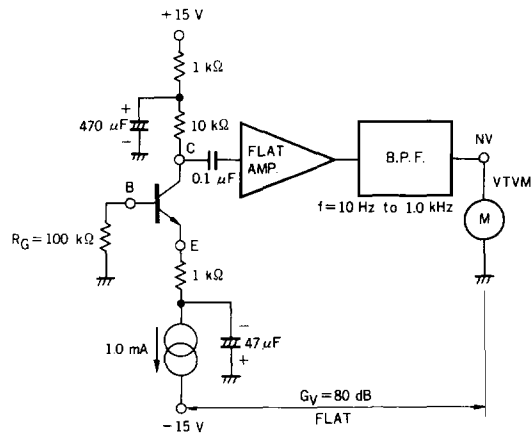

$V_{CE} = 5$  V,  $I_C = 1.0$  mA,  $R_G = 100$  k $\Omega$ ,  $G_V \cong 80$  dB, FLAT( $f = 10$  Hz to 1.0 kHz)