

BMR 463 series POL Regulators
 Input 4.5-14 V, Output up to 20 A / 66 W

EN/LZT 146 434 R1A January 2011

© Ericsson AB

Key Features

- Small package
25.65 x 13.8 x 8.2 mm (1.01 x 0.543 x 0.323 in)
- 0.6 V - 3.3 V output voltage range
- High efficiency, typ. 97.1% at 5Vin, 3.3Vout half load
- Configuration and Monitoring via PMBus
- Synchronization & phase spreading
- Current sharing, Voltage Tracking & Voltage margining
- MTBF 20 Mh

General Characteristics

- Fully regulated
- For narrow board pitch applications (15 mm/0.6 in)
- Non-Linear Response for reduction of decoupling cap.
- Input under voltage shutdown
- Over temperature protection
- Output short-circuit & Output over voltage protection
- Remote Control & Power Good
- Voltage setting via pin-strap or PMBus
- Advanced Configurable via Graphical Used Interface
- ISO 9001/14001 certified supplier
- Highly automated manufacturing ensures quality

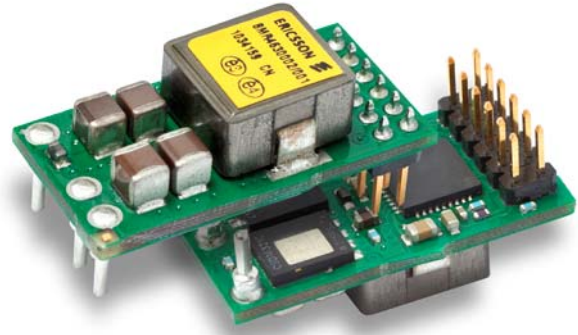

Safety Approvals



Design for Environment



Meets requirements in high-temperature lead-free soldering processes.

Contents

Ordering Information	2
General Information	2
Safety Specification	3
Absolute Maximum Ratings	4
Electrical Specification		
0.6-3.3 V, 20 A/ 66 W	BMR463.....	5
EMC Specification	14
Operating Information	14
Thermal Consideration	20
Connections	21
Mechanical Information	27
Soldering Information	30
Delivery Information	30
Product Qualification Specification	31

BMR 463 series POL Regulators
Input 4.5-14 V, Output up to 20 A / 66 W

EN/LZT 146 434 R1A January 2011

© Ericsson AB

Ordering Information

Product program	Output
BMR 463	0.6-3.3 V, 20 A/ 66 W

Product number and Packaging

BMR 463 n ₁ n ₂ n ₃ n ₄ /n ₅ n ₆ n ₇ n ₈									
Options	n ₁	n ₂	n ₃	n ₄	/	n ₅	n ₆	n ₇	n ₈
Mounting	o				/				
Mechanical		o			/				
Interface			o	o	/				
Configuration					/	o	o	o	
Packaging					/				o

Options	Description
n ₁	0 Through hole mount version (TH) 1 Surface mount version (SMD)
n ₂	0 Open frame
n ₃ n ₄	02 PMBus and analog pin strap
n ₅ n ₆ n ₇	001 Basic configuration
n ₈	C Antistatic tape & reel of 200 products (1 full reel/box =200 products)

Example: A through-hole mounted, open frame, PMBus and analog pin strap, basic configuration with antistatic tape & reel packaging would be BMR 463 0002/001C

General Information

Reliability

The failure rate (λ) and mean time between failures (MTBF) is calculated at max output power and an operating ambient temperature (T_A) of +40°C. Different calculations methods could be used which may give different results. Ericsson Power Modules uses Telcordia SR-332 Issue 2 Method 1 (parts count method) to calculate the mean steady-state failure rate and standard deviation (σ). MTBF = $1/\lambda$.

MTBF for the BMR 463 series = 20 Mh and σ = 12 Mh

Telcordia SR-332 Issue 2 also provides techniques to estimate the upper confidence levels of failure rates based on the mean and standard deviation.

MTBF at 90% confidence level = 15 Mh

Compatibility with RoHS requirements

The products are compatible with the relevant clauses and requirements of the RoHS directive 2002/95/EC and have a maximum concentration value of 0.1% by weight in homogeneous materials for lead, mercury, hexavalent chromium, PBB and PBDE and of 0.01% by weight in homogeneous materials for cadmium.

Exemptions in the RoHS directive utilized in Ericsson Power Modules products include:

- Lead in glass of electronics components [5]
- Lead as an alloying element in copper alloy containing up to 4% lead by weight [6 c]
- Lead in high melting temperature type solder [7a]
- Lead in electronic ceramic parts [7c]
- Lead in solders to complete a viable connection between semiconductor die and carrier within integrated circuit flip chip packages [15]

Quality Statement

The products are designed and manufactured in an industrial environment where quality systems and methods like ISO 9000, Six Sigma, and SPC are intensively in use to boost the continuous improvements strategy. Infant mortality or early failures in the products are screened out and they are subjected to an ATE-based final test. Conservative design rules, design reviews and product qualifications, plus the high competence of an engaged work force, contribute to the high quality of our products.

Warranty

Warranty period and conditions are defined in Ericsson Power Modules General Terms and Conditions of Sale.

Limitation of Liability

Ericsson Power Modules does not make any other warranties, expressed or implied including any warranty of merchantability or fitness for a particular purpose (including, but not limited to, use in life support applications, where malfunctions of product can cause injury to a person's health or life).

© Ericsson AB 2011

The information and specifications in this technical specification is believed to be correct at the time of publication. However, no liability is accepted for inaccuracies, printing errors or for any consequences thereof. Ericsson AB reserves the right to change the contents of this technical specification at any time without prior notice.

BMR 463 series POL Regulators
Input 4.5-14 V, Output up to 20 A / 66 W

EN/LZT 146 434 R1A January 2011

© Ericsson AB

Safety Specification

General information

Ericsson Power Modules DC/DC converters and DC/DC regulators are designed in accordance with safety standards IEC/EN/UL 60950-1 *Safety of Information Technology Equipment*.

IEC/EN/UL 60950-1 contains requirements to prevent injury or damage due to the following hazards:

- Electrical shock
- Energy hazards
- Fire
- Mechanical and heat hazards
- Radiation hazards
- Chemical hazards

On-board DC/DC converters and DC/DC regulators are defined as component power supplies. As components they cannot fully comply with the provisions of any safety requirements without "Conditions of Acceptability". Clearance between conductors and between conductive parts of the component power supply and conductors on the board in the final product must meet the applicable safety requirements. Certain conditions of acceptability apply for component power supplies with limited stand-off (see Mechanical Information for further information). It is the responsibility of the installer to ensure that the final product housing these components complies with the requirements of all applicable safety standards and regulations for the final product.

Component power supplies for general use should comply with the requirements in IEC 60950-1, EN 60950-1 and UL 60950-1 *Safety of Information Technology Equipment*. There are other more product related standards, e.g. IEEE 802.3 *CSMA/CD (Ethernet) Access Method*, and ETS-300132-2 *Power supply interface at the input to telecommunications equipment, operated by direct current (dc)*, but all of these standards are based on IEC/EN/UL 60950-1 with regards to safety.

Ericsson Power Modules DC/DC converters and DC/DC regulators are UL 60950-1 recognized and certified in accordance with EN 60950-1.

The flammability rating for all construction parts of the products meet requirements for V-0 class material according to IEC 60695-11-10, *Fire hazard testing, test flames* – 50 W horizontal and vertical flame test methods.

The products should be installed in the end-use equipment, in accordance with the requirements of the ultimate application. Normally the output of the DC/DC converter is considered as SELV (Safety Extra Low Voltage) and the input source must be isolated by minimum Double or Reinforced Insulation from the primary circuit (AC mains) in accordance with IEC/EN/UL 60950-1.

Isolated DC/DC converters

It is recommended that a slow blow fuse is to be used at the input of each DC/DC converter. If an input filter is used in the circuit the fuse should be placed in front of the input filter.

In the rare event of a component problem that imposes a short circuit on the input source, this fuse will provide the following functions:

- Isolate the fault from the input power source so as not to affect the operation of other parts of the system.
- Protect the distribution wiring from excessive current and power loss thus preventing hazardous overheating.

The galvanic isolation is verified in an electric strength test. The test voltage (V_{iso}) between input and output is 1500 Vdc or 2250 Vdc (refer to product specification).

24 V DC systems

The input voltage to the DC/DC converter is SELV (Safety Extra Low Voltage) and the output remains SELV under normal and abnormal operating conditions.

48 and 60 V DC systems

If the input voltage to the DC/DC converter is 75 Vdc or less, then the output remains SELV (Safety Extra Low Voltage) under normal and abnormal operating conditions.

Single fault testing in the input power supply circuit should be performed with the DC/DC converter connected to demonstrate that the input voltage does not exceed 75 Vdc.

If the input power source circuit is a DC power system, the source may be treated as a TNV-2 circuit and testing has demonstrated compliance with SELV limits in accordance with IEC/EN/UL60950-1.

Non-isolated DC/DC regulators

The input voltage to the DC/DC regulator is SELV (Safety Extra Low Voltage) and the output remains SELV under normal and abnormal operating conditions.

BMR 463 series POL Regulators
 Input 4.5-14 V, Output up to 20 A / 66 W

EN/LZT 146 434 R1A January 2011

© Ericsson AB

Absolute Maximum Ratings

Characteristics		min	typ	max	Unit
T_{P1}	Operating temperature (see Thermal Consideration section)	-40		120	°C
T_s	Storage temperature	-40		125	°C
V_I	Input voltage (See Operating Information Section for input and output voltage relations)	-0.3		16	V
Logic I/O voltage	CTRL, SA0, SALERT, SCL, SDA, VSET, SYNC, GCB	-0.3		6.5	V
Ground voltage differential	S-, PREF, GND	-0.3		0.3	V
Analog pin voltage	V_o , S+, VTRK	-0.3		6.5	V

Stress in excess of Absolute Maximum Ratings may cause permanent damage. Absolute Maximum Ratings, sometimes referred to as no destruction limits, are normally tested with one parameter at a time exceeding the limits in the Electrical Specification. If exposed to stress above these limits, function and performance may degrade in an unspecified manner.

Fundamental Circuit Diagram

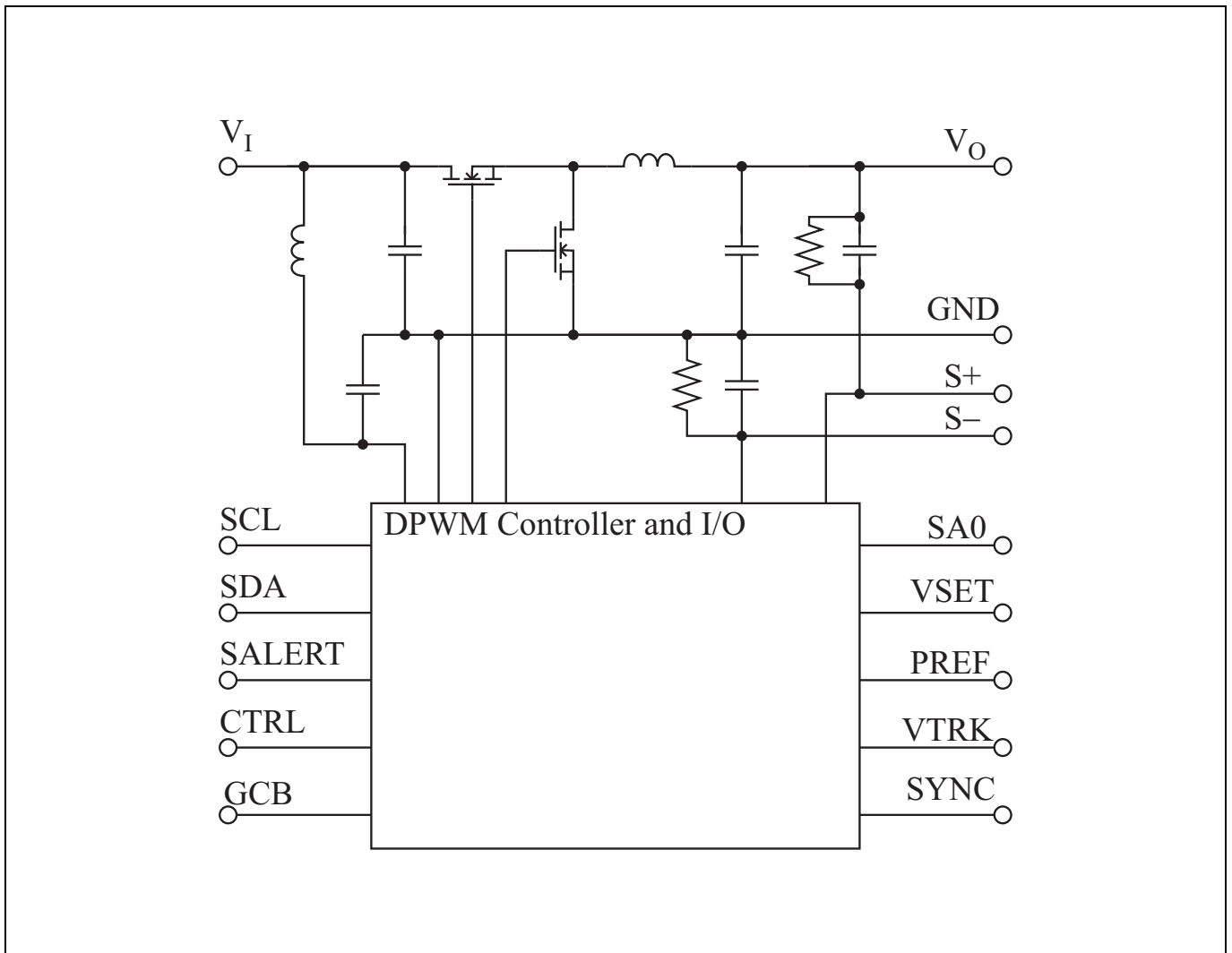

BMR 463 series POL Regulators
 Input 4.5-14 V, Output up to 20 A / 66 W

EN/LZT 146 434 R1A January 2011

© Ericsson AB

Electrical Specification
BMR 463
 $T_{P1} = -30$ to $+85^{\circ}\text{C}$, $V_I = 4.5$ to 14 V

 Typical values given at: $T_{P1} = +25^{\circ}\text{C}$, $V_I = 12.0$ V, max I_O , unless otherwise specified under Conditions.

Basic configuration (configuration file: 190 10-CDA 102 0175/001)

 Additional $C_I = 470$ μF , $C_O = 470$ μF . See Operating Information section for selection of capacitor types.

Sense pins are connected to the output pins.

Characteristics	Conditions	min	typ	max	Unit
V_I	Input voltage rise time	monotonic		5	ms

V_O	Output voltage without pin stap		1.2		V		
	Output voltage adjustment range		$V_I > V_O + 1.0$ V		0.60	3.30	V
	Output voltage adjustment including margining		$V_I > V_O + 1.0$ V		0.54	3.63	V
	Output voltage set-point resolution				± 0.025	% V_O	
	Output voltage accuracy		Includes, line, load, temp.		-1	1	%
	Line regulation	$V_O = 0.6$ V		2		mV	
		$V_O = 1.0$ V		2			
		$V_O = 1.8$ V		2			
		$V_O = 3.3$ V		3			
	Load regulation; $I_{out} = 0 - 100\%$	$V_O = 0.6$ V		3		mV	
$V_O = 1.0$ V		2					
$V_O = 1.8$ V		2					
$V_O = 3.3$ V		2					
V_{Oac}	Output ripple & noise		$V_O = 0.6$ V		mVp-p		
			$V_O = 1.0$ V				
			$V_O = 1.8$ V				
			$V_O = 3.3$ V				

I_O	Output current		20		A			
I_S	Static input current		$V_O = 0.6$ V		A			
			$V_O = 1.0$ V					
			$V_O = 1.8$ V					
			$V_O = 3.3$ V					
I_{lim}	Current limit threshold		Full working range		22	25	30	A
I_{sc}	Short circuit current	RMS, hiccup mode, See Note 3	$V_O = 0.6$ V		8		A	
			$V_O = 1.0$ V		6			
			$V_O = 1.8$ V		5			
			$V_O = 3.3$ V		4			

η	Efficiency	50% of max I_O	$V_O = 0.6$ V		84.0		%
			$V_O = 1.0$ V		89.3		
			$V_O = 1.8$ V		92.8		
			$V_O = 3.3$ V		94.8		
	max I_O	$V_O = 0.6$ V		79.3		%	
		$V_O = 1.0$ V		86.0			
		$V_O = 1.8$ V		90.7			
		$V_O = 3.3$ V		93.6			
P_d	Power dissipation		$V_O = 0.6$ V		3.12		W
			$V_O = 1.0$ V		3.25		
			$V_O = 1.8$ V		3.68		
			$V_O = 3.3$ V		4.52		
P_{ii}	Input idling power	Factory default: Continuous Conduction Mode, CCM	$V_O = 0.6$ V		0.56		W
			$V_O = 1.0$ V		0.57		
			$V_O = 1.8$ V		0.68		
			$V_O = 3.3$ V		0.99		
	DCM, Discontinuous Conduction Mode (diode emulation)	$V_O = 0.6$ V		0.36		W	
		$V_O = 1.0$ V		0.30			
		$V_O = 1.8$ V		0.20			
		$V_O = 3.3$ V		0.21			

BMR 463 series POL Regulators
 Input 4.5-14 V, Output up to 20 A / 66 W

EN/LZT 146 434 R1A January 2011

© Ericsson AB

		DCM with Adaptive Frequency and Minimum Pulse Enabled	$V_o = 0.6\text{ V}$	0.26	W
			$V_o = 1.0\text{ V}$	0.27	
			$V_o = 1.8\text{ V}$	0.34	
			$V_o = 3.3\text{ V}$	0.43	
		DCM with Adaptive Frequency and Minimum Pulse Disabled	$V_o = 0.6\text{ V}$	0.25	W
			$V_o = 1.0\text{ V}$	0.20	
			$V_o = 1.8\text{ V}$	0.20	
			$V_o = 3.3\text{ V}$	0.20	
P_{CTRL}	Input standby power	Turned off with CTRL-pin	Factory default: Monitoring enabled, Precise timing enabled	180	mW
			Monitoring enabled, Precise timing disabled	120	
			Low power mode: Monitoring disabled, Precise timing disabled	85	mW

C_i	Internal input capacitance		70	μF
C_{oi}	Internal output capacitance		200	μF
C_o	Total external output capacitance	300	15 000	μF
	ESR range of capacitors (per single capacitor)	5	30	m Ω

V_{tr1}	Load transient peak voltage deviation	Factory default configuration $di/dt = 2\text{ A}/\mu\text{s}$	$V_o = 0.6\text{ V}$	210	mV
			$V_o = 1.0\text{ V}$	220	
			$V_o = 1.8\text{ V}$	220	
			$V_o = 3.3\text{ V}$	240	
	Load step 25-75-25% of max I_o	Optimized PID and NLR configuration $di/dt = 2\text{ A}/\mu\text{s}$	$V_o = 0.6\text{ V}$	60	
			$V_o = 1.0\text{ V}$	70	
			$V_o = 1.8\text{ V}$	70	
			$V_o = 3.3\text{ V}$	80	
t_{tr1}	Load transient recovery time, Note 5	Factory default configuration $di/dt = 2\text{ A}/\mu\text{s}$	$V_o = 0.6\text{ V}$	120	μs
			$V_o = 1.0\text{ V}$	100	
			$V_o = 1.8\text{ V}$	100	
			$V_o = 3.3\text{ V}$	50	
	Load step 25-75-25% of max I_o	Optimized PID and NLR configuration $di/dt = 2\text{ A}/\mu\text{s}$	$V_o = 0.6\text{ V}$	30	
			$V_o = 1.0\text{ V}$	25	
			$V_o = 1.8\text{ V}$	25	
			$V_o = 3.3\text{ V}$	20	

f_s	Switching frequency	Factory default	320	kHz	
	Switching frequency range	See Note 7	200	640	kHz
	Switching frequency set-point accuracy		± 5	%	
	Maximum PWM Duty Cycle		5	95	%
	Minimum Sync Pulse Width		150		ns
	Synchronization Frequency Tolerance	External clock source		± 13	%

Input Under Voltage Lockout, UVLO	UVLO Threshold	Factory default	3.85	V	
	UVLO Threshold range		3.85	14	V
	Set point accuracy		-200	200	mV
	Hysteresis	Factory default	0.35		V
	Hysteresis range		0	10.15	V
	Delay			2.5	μs
Input Over Voltage Protection	Fault response	Factory default, See Note 3	Automatic restart, 70ms		
	IOVP Threshold	Factory default	16	V	
	IOVP Threshold range		4.2	16	V
	Set point accuracy		± 200		mV
	Hysteresis	Factory default	1		V
	Hysteresis range		0	11.8	V
Delay			2.5	μs	

Technical Specification

BMR 463 series POL Regulators
 Input 4.5-14 V, Output up to 20 A / 66 W

EN/LZT 146 434 R1A January 2011

© Ericsson AB

	Fault response	Factory default, See Note 3	Automatic restart, 70ms		
Power Good, PG, See Note 2	PG threshold	Factory default	90		% V _O
	PG hysteresis	Factory default	5		% V _O
	PG delay	Factory default	10		ms
	PG delay range		0	500	s
Output voltage Over/Under Voltage Protection, OVP/UVP	UVP threshold	Factory default	85		% V _O
	UVP range		0	110	% V _O
	UVP hysteresis		5		% V _O
	OVP threshold	Factory default	115		% V _O
	OVP range		0	115	% V _O
	UVP/OVP Response time	Factory default	25		μs
	UVP/OVP Response time range		5	60	μs
	Fault response	Factory default, See Note 3	Automatic restart, 70ms		
Over Current Protection, OCP	Threshold	Factory default	25		A
	Threshold range		0	25	A
	Set-point accuracy		±10		% of Full Scale
	Protection delay, See Note 4	Factory default	5		T _{sw}
	Protection delay range		1	32	T _{sw}
	Fault response	Factory default, See Note 3	Automatic restart, 70ms		
Over Temperature Protection, OTP at P1	Threshold	Factory default	120		°C
	Threshold range		-40	120	°C
	Hysteresis	Factory default	15		°C
	Hysteresis range		0	160	°C
	Fault response	Factory default, See Note 3	Automatic restart, 70ms		

V _{IL}	Logic input low threshold	SALERT, SCL, SDA, VSET, GCB	0.8		V
V _{IH}	Logic input high threshold		2		V
V _{OL}	Logic output low (sinking)	SALERT, SCL, SDA, VSET, GCB I _{OL} ≤ 4 mA	0.4		V
V _{OH}	Logic output high (sourcing)	SALERT, SCL, SDA, VSET, GCB I _{OL} ≤ 2 mA	2.25		V
t _{set}	Setup time, SMBus	See Note 1	300		ns
t _{hold}	Hold time, SMBus	See Note 1	250		ns
C _p	Internal capacitance on pins	SCL,SDA, SALERT,GCB	10		pF

Delay Time	Delay duration, Note 6	Factory default	10		ms	
	Delay duration range		2	500 000		
	Delay accuracy	CTRL controlled Precise timing enabled Factory default		±0.25		ms
		PMBus controlled Precise timing disabled		-0.25/+4		ms
Ramp Time	Ramp duration	Factory default	10		ms	
	Ramp duration range		0	200		
	Ramp time accuracy		100		μs	

VTRK Input Bias Current	VTRK = 5.5 V		110	200	μA
VTRK Tracking Static Accuracy, Note 8	100% Tracking (V _{OUT} -VTRK)		-100	100	mV
VTRK Regulation Accuracy	100% Tracking (V _{OUT} -VTRK)		-1	1	%

Current share accuracy			20		% of Full Sscale
Number of modules in current sharing group			1	8	

VIN_READ, 0x88h	Accuracy vs. V _I		3		%
-----------------	-----------------------------	--	---	--	---

Technical Specification

BMR 463 series POL Regulators
 Input 4.5-14 V, Output up to 20 A / 66 W

EN/LZT 146 434 R1A January 2011

© Ericsson AB

VOUT_READ, 0x8Bh	Accuracy vs. V_O		1	%
IOUT_READ, 0x8Ch	Accuracy vs. I_O	$V_I = 12\text{ V}, V_O = 1\text{ V},$ $T_{P1} = 0\text{ to }+85^\circ\text{C}$	± 1.4	A
IOUT_READ, 0x8Ch	Accuracy vs. I_O	$V_I = 4.5\text{-}14\text{ V}, V_O = 1\text{ V},$ $T_{P1} = 0\text{ to }+85^\circ\text{C}$	± 2.6	A

Note 1: See Power Management section for I2C/SMBus Setup and Hold Times – Definitions.

Note 2: Monitorable over PMBus Interface.

Note 3: Continuous re-starts with 70 ms between each start. See Power Management section for additional fault response types.

 Note 4: T_{sw} is the switching period.

 Note 5: Within +/-3% of V_O

Note 6: See Soft-start Power Up section.

Note 7: The product is not fully verified outside default switching frequency.

Note 8: In a dynamical case accuracy will depend on VTRK slewrate and the regulator bandwidth.

BMR 463 series POL Regulators
 Input 4.5-14 V, Output up to 20 A / 66 W

EN/LZT 146 434 R1A January 2011

© Ericsson AB

Typical Characteristics
Efficiency and Power Dissipation

BMR 463

Efficiency vs. Output Current at $V_I = 5\text{ V}$

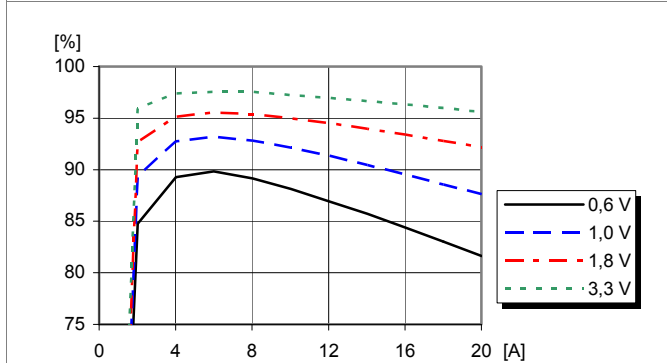

Efficiency vs. load current and output voltage:
 $T_{P1} = +25^\circ\text{C}$, $V_I = 5\text{ V}$, $f_{sw} = 320\text{ kHz}$, $C_O = 470\text{ }\mu\text{F}$. Default Configuration.

Power Dissipation vs. Output Current at $V_I = 5\text{ V}$

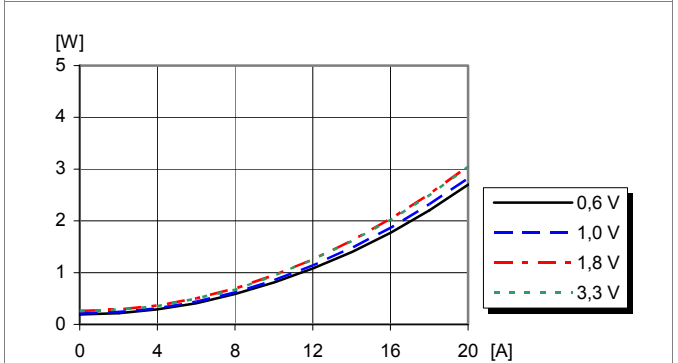

Dissipated power vs. load current and output voltage:
 $T_{P1} = +25^\circ\text{C}$, $V_I = 5\text{ V}$, $f_{sw} = 320\text{ kHz}$, $C_O = 470\text{ }\mu\text{F}$. Default Configuration.

Efficiency vs. Output Current at $V_I = 12\text{ V}$

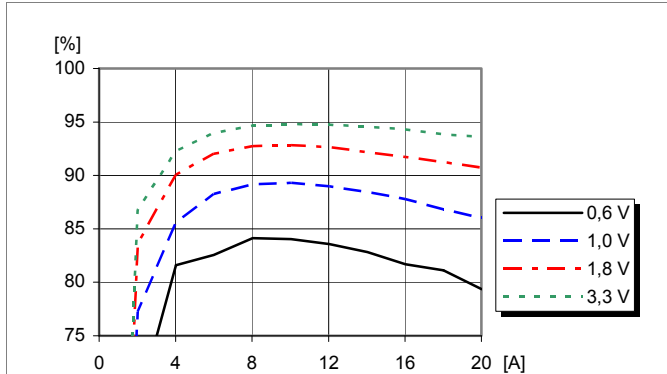

Efficiency vs. load current and output voltage at
 $T_{P1} = +25^\circ\text{C}$, $V_I = 12\text{ V}$, $f_{sw} = 320\text{ kHz}$, $C_O = 470\text{ }\mu\text{F}$. Default Configuration.

Power Dissipation vs. Output Current at $V_I = 12\text{ V}$

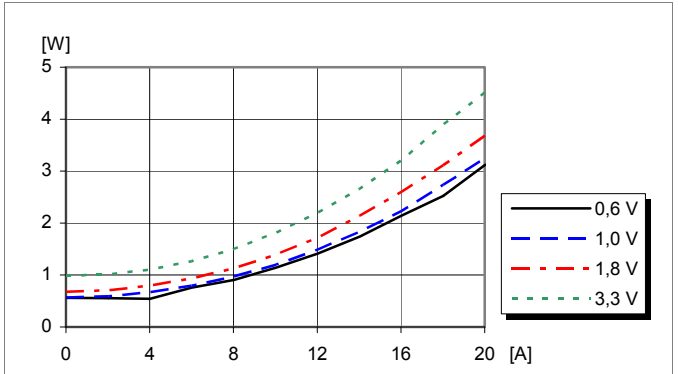

Dissipated power vs. load current and output voltage:
 $T_{P1} = +25^\circ\text{C}$, $V_I = 12\text{ V}$, $f_{sw} = 320\text{ kHz}$, $C_O = 470\text{ }\mu\text{F}$. Default Configuration.

Efficiency vs. Output Current and Switch Frequency

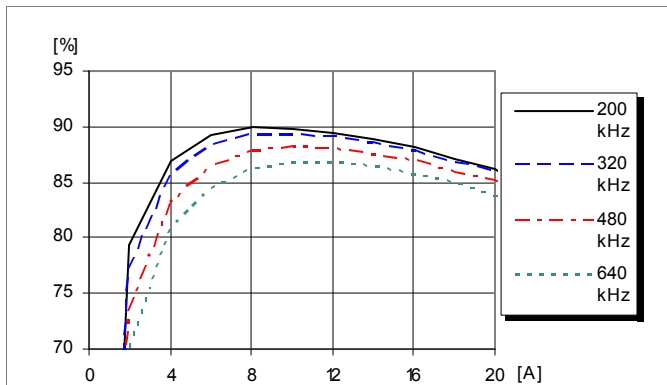

Efficiency vs. load current and switch frequency at
 $T_{P1} = +25^\circ\text{C}$, $V_I = 12\text{ V}$, $V_O = 1.0\text{ V}$, $C_O = 470\text{ }\mu\text{F}$.

Power Dissipation vs. Output Current and Switch Frequency

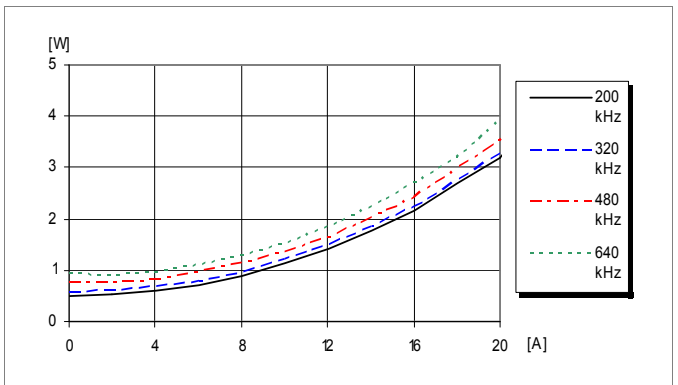

Dissipated power vs. load current and switch frequency at
 $T_{P1} = +25^\circ\text{C}$, $V_I = 12\text{ V}$, $V_O = 1.0\text{ V}$, $C_O = 470\text{ }\mu\text{F}$.

BMR 463 series POL Regulators
 Input 4.5-14 V, Output up to 20 A / 66 W

EN/LZT 146 434 R1A January 2011

© Ericsson AB

Typical Characteristics
Load Transient

BMR 463

Load Transient vs. Decoupling Capacitance, $V_O = 1.0 V$

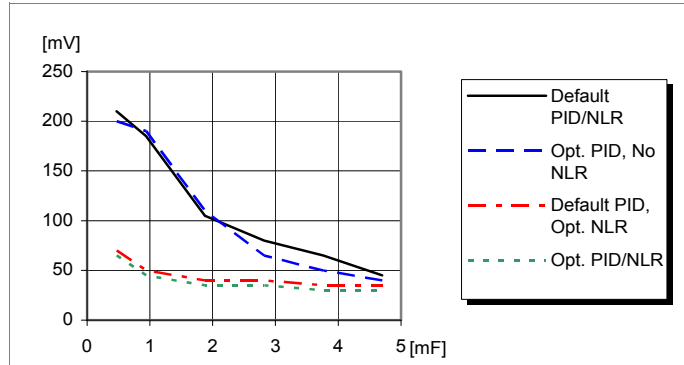

Load transient peak voltage deviation vs. decoupling capacitance. Step-change (5-15-5 A). Parallel coupling of capacitors with 470 μF / 10 m Ω , $T_{P1} = +25^\circ C$, $V_I = 12 V$, $V_O = 1.0 V$, $f_{sw} = 320 kHz$, $di/dt = 2 A/\mu s$

Load Transient vs. Decoupling Capacitance, $V_O = 3.3 V$

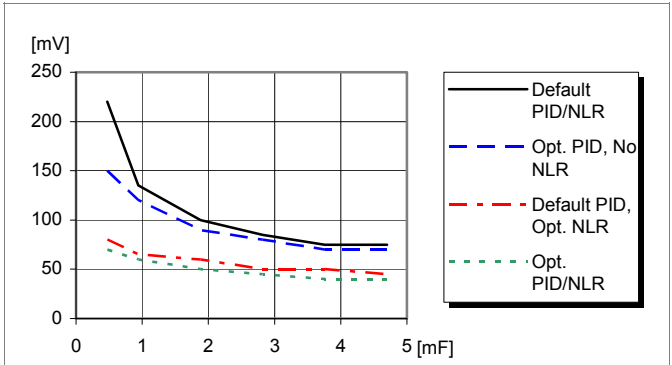

Load transient peak voltage deviation vs. decoupling capacitance. Step-change (5-15-5 A). Parallel coupling of capacitors with 470 μF / 10 m Ω , $T_{P1} = +25^\circ C$, $V_I = 12 V$, $V_O = 3.3 V$, $f_{sw} = 320 kHz$, $di/dt = 2 A/\mu s$

Load transient vs. Switch Frequency

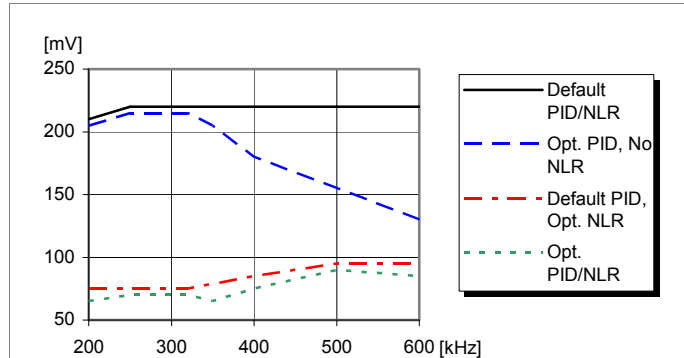

Load transient peak voltage deviation vs. frequency. Step-change (5-15-5 A). $T_{P1} = +25^\circ C$, $V_I = 12 V$, $V_O = 1.0 V$, $C_O = 470 \mu F$.

Output Load Transient Response, Default

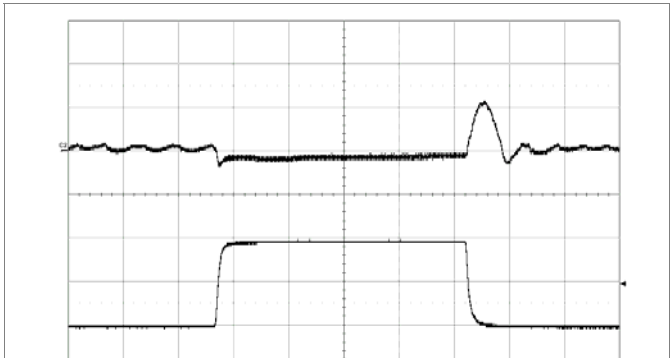

Output voltage response to load current step-change (5-15-5 A) at: $T_{P1} = +25^\circ C$, $V_I = 12 V$, $V_O = 1.0 V$, $di/dt = 2 A/\mu s$, $f_{sw} = 320 kHz$, $C_O = 470 \mu F$. Default PID Control Loop and NLR. Top trace: output voltage (200 mV/div.). Bottom trace: load current (5 A/div.). Time scale: (0.1 ms/div.).

Output Load Transient Response, Optimized PID, no NLR

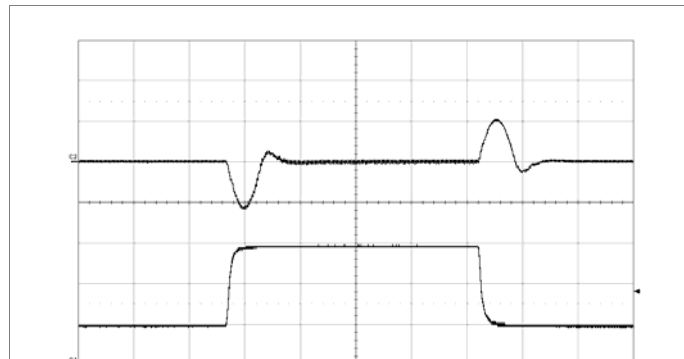

Output voltage response to load current step-change (5-15-5 A) at: $T_{P1} = +25^\circ C$, $V_I = 12 V$, $V_O = 1.0 V$, $di/dt = 2 A/\mu s$, $f_{sw} = 320 kHz$, $C_O = 470 \mu F$. Optimized PID Control Loop and no NLR. Top trace: output voltage (200 mV/div.). Bottom trace: load current (5 A/div.). Time scale: (0.1 ms/div.).

Output Load Transient Response, Optimized NLR

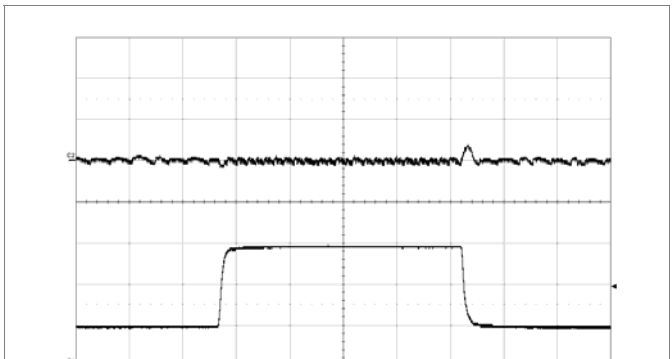

Output voltage response to load current step-change (5-15-5 A) at: $T_{P1} = +25^\circ C$, $V_I = 12 V$, $V_O = 1.0 V$, $di/dt = 2 A/\mu s$, $f_{sw} = 320 kHz$, $C_O = 470 \mu F$. Default PID Control Loop and optimized NLR. Top trace: output voltage (200 mV/div.). Bottom trace: load current (5 A/div.). Time scale: (0.1 ms/div.).

BMR 463 series POL Regulators
 Input 4.5-14 V, Output up to 20 A / 66 W

EN/LZT 146 434 R1A January 2011

© Ericsson AB

Typical Characteristics
Output Current Characteristic

BMR 463

Output Current Derating, $V_O = 0.6\text{ V}$

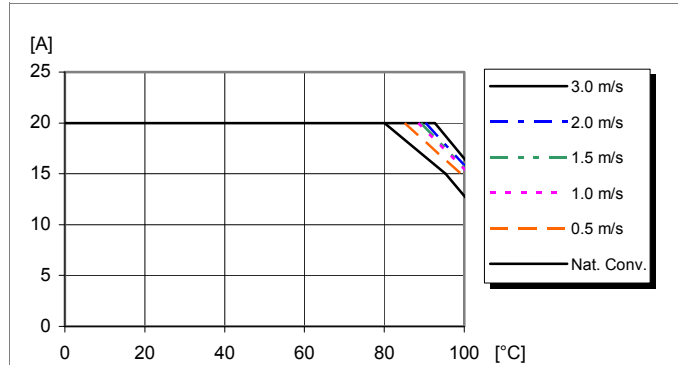

Available load current vs. ambient air temperature and airflow at $V_O = 0.6\text{ V}$, $V_I = 12\text{ V}$. See Thermal Consideration section.

Output Current Derating, $V_O = 1.0\text{ V}$

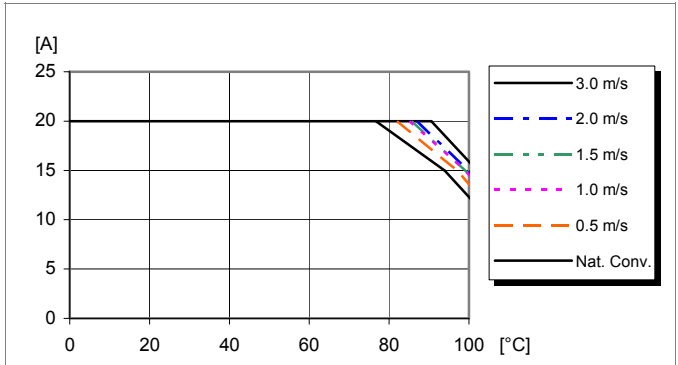

Available load current vs. ambient air temperature and airflow at $V_O = 1.0\text{ V}$, $V_I = 12\text{ V}$. See Thermal Consideration section.

Output Current Derating, $V_O = 1.8\text{ V}$

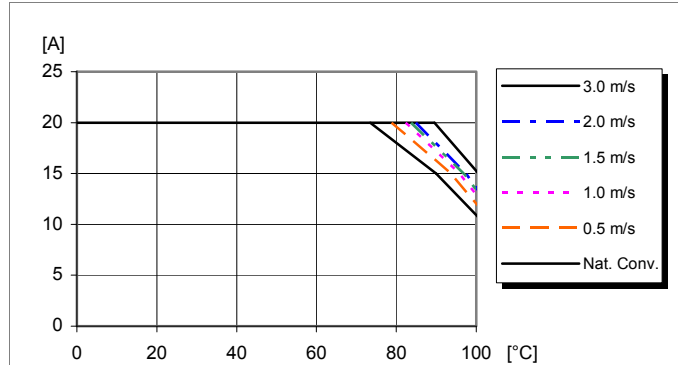

Available load current vs. ambient air temperature and airflow at $V_O = 1.8\text{ V}$, $V_I = 12\text{ V}$. See Thermal Consideration section.

Output Current Derating, $V_O = 3.3\text{ V}$

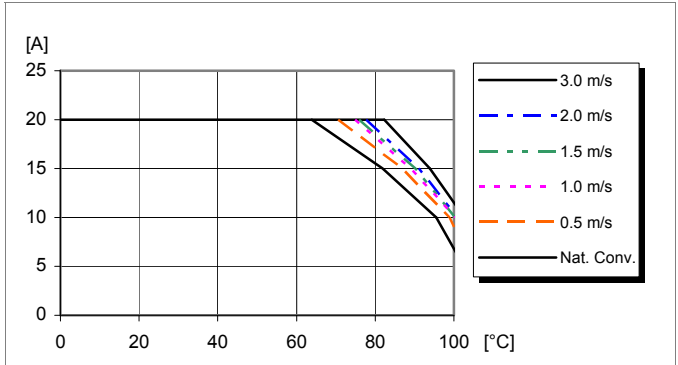

Available load current vs. ambient air temperature and airflow at $V_O = 3.3\text{ V}$, $V_I = 12\text{ V}$. See Thermal Consideration section.

Current Limit Characteristics, $V_O = 1.0\text{ V}$

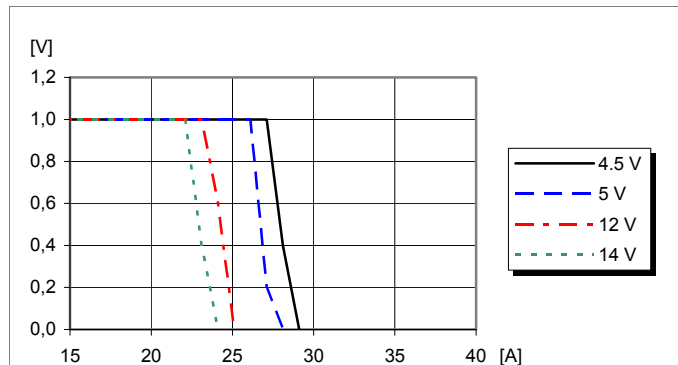

Output voltage vs. load current at $T_{P1} = +25^\circ\text{C}$.

Current Limit Characteristics, $V_O = 3.3\text{ V}$

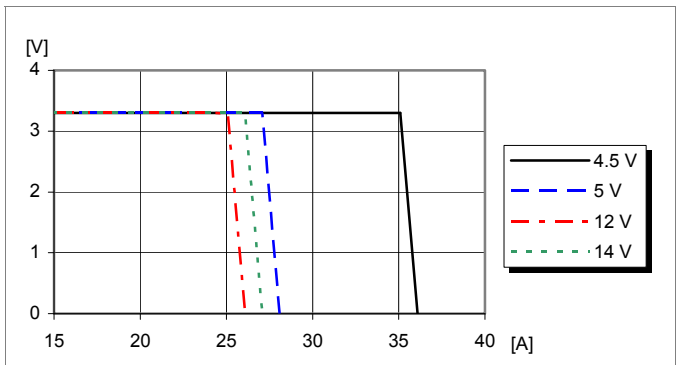

Output voltage vs. load current at $T_{P1} = +25^\circ\text{C}$.

BMR 463 series POL Regulators
 Input 4.5-14 V, Output up to 20 A / 66 W

EN/LZT 146 434 R1A January 2011

© Ericsson AB

Typical Characteristics
Output Voltage

BMR 463

Output Ripple & Noise, $V_O = 1.0\text{ V}$

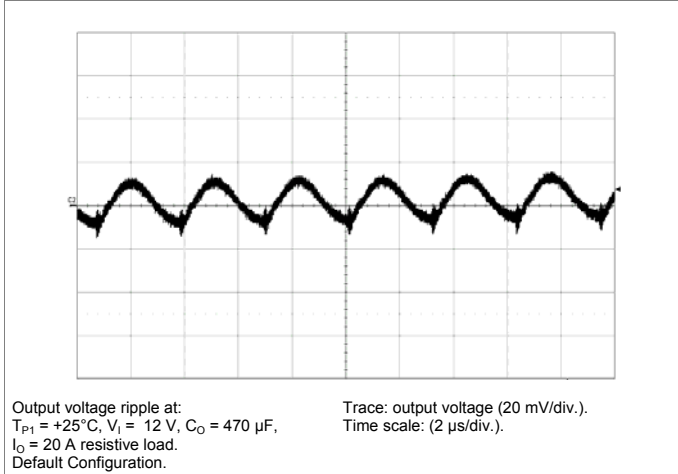

Output Ripple & Noise, $V_O = 3.3\text{ V}$

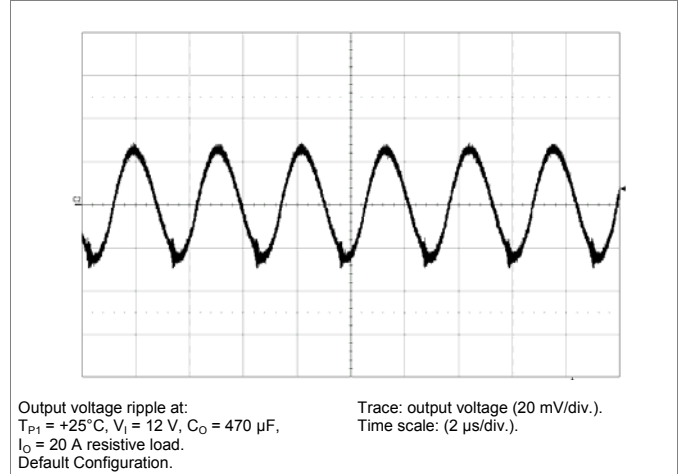

Output Ripple vs. Input Voltage

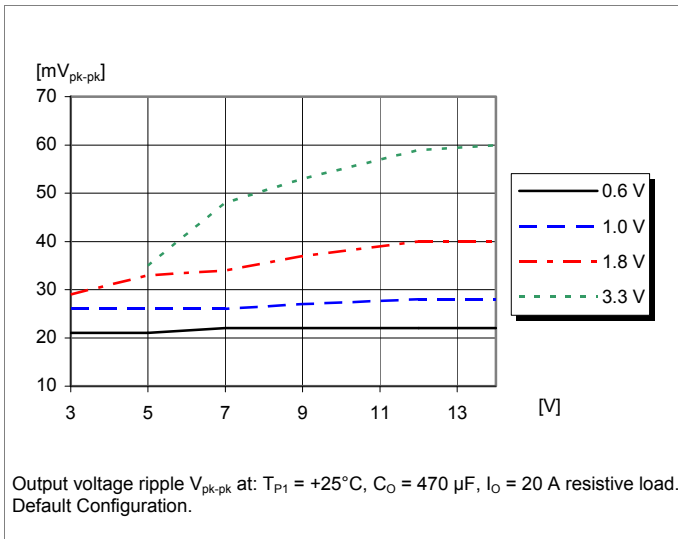

Output Ripple vs. Frequency

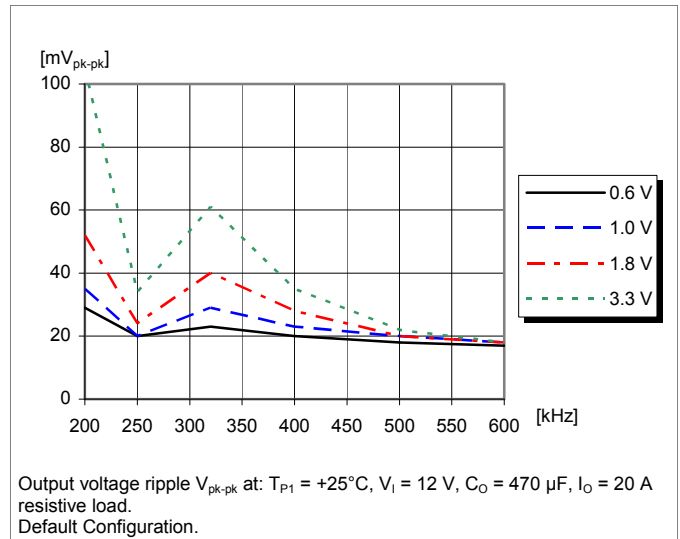

Load regulation, $V_O = 1.0\text{ V}$

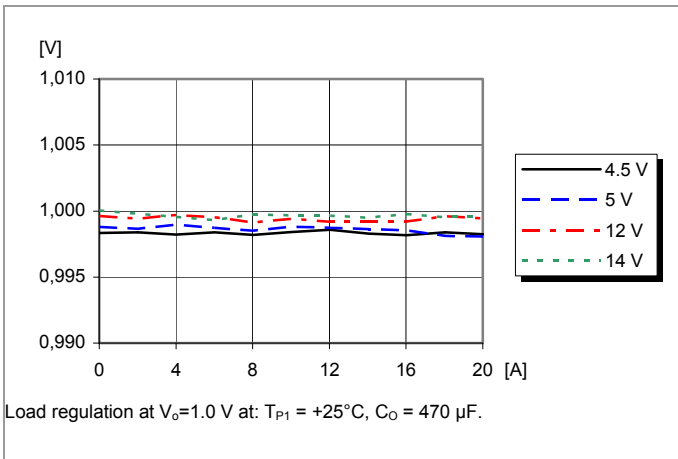

Load regulation, $V_O = 3.3\text{ V}$

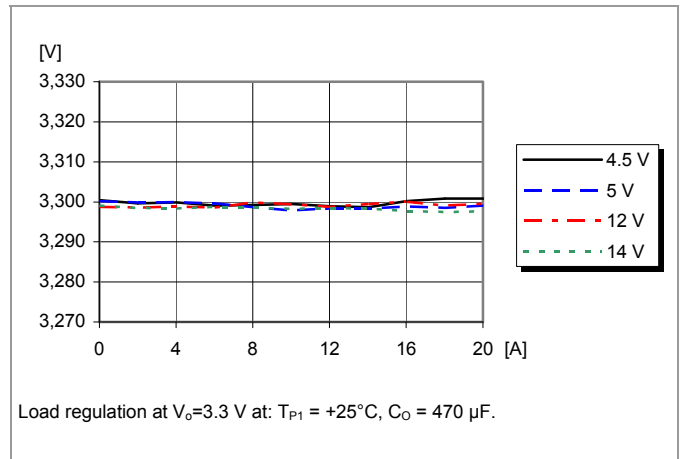

BMR 463 series POL Regulators
 Input 4.5-14 V, Output up to 20 A / 66 W

EN/LZT 146 434 R1A January 2011

© Ericsson AB

Typical Characteristics
Start-up and shut-down

BMR 463

Start-up by input source

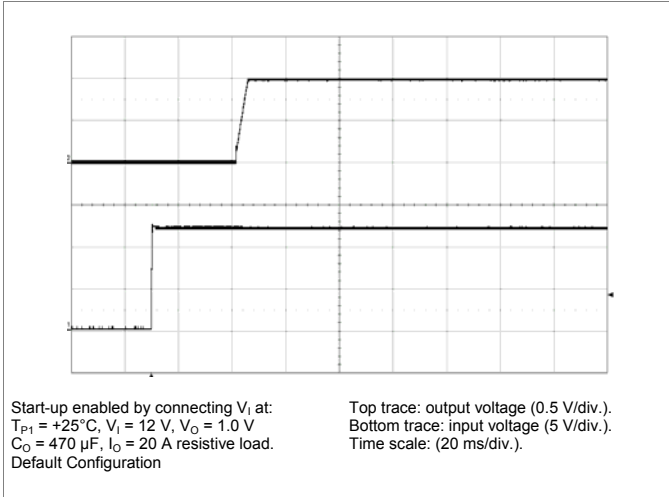

Shut-down by input source

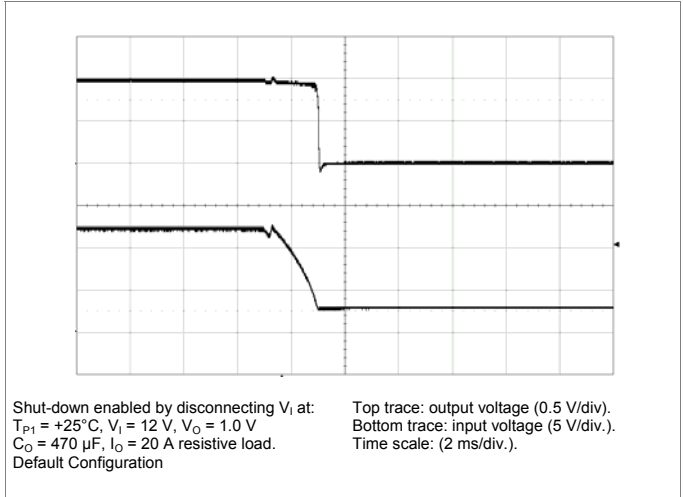

Start-up by CTRL signal

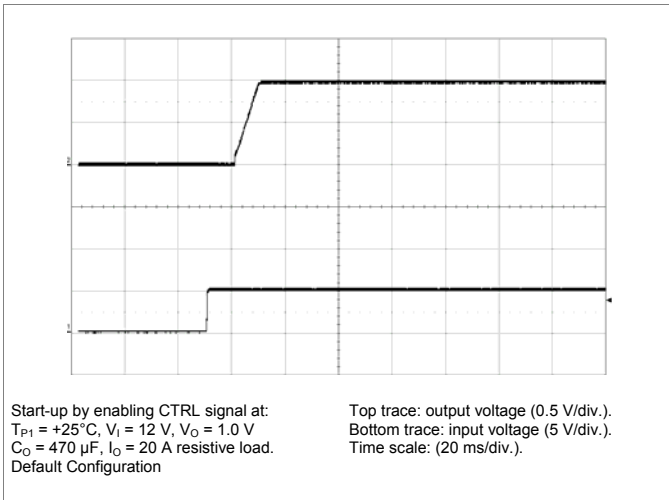

Shut-down by CTRL signal

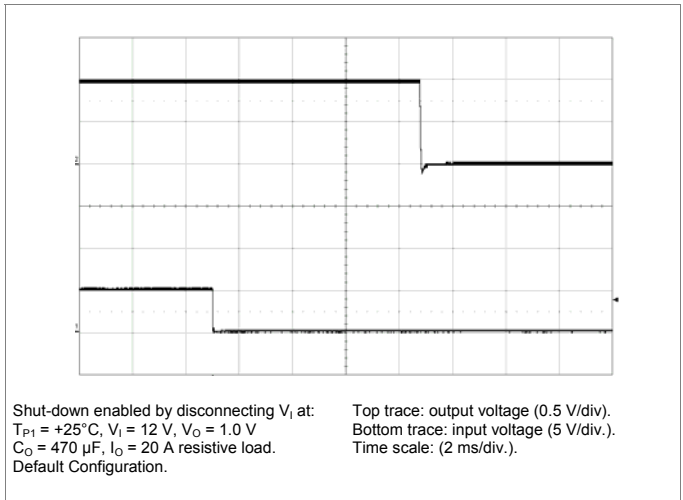

BMR 463 series POL Regulators
 Input 4.5-14 V, Output up to 20 A / 66 W

EN/LZT 146 434 R1A January 2011

© Ericsson AB

EMC Specification

Conducted EMI measured according to test set-up and standard MIL std 0141 - 58000.
 The fundamental switching frequency is 320 kHz for BMR463 at $V_1 = 12.0$ V, max I_O .

Conducted EMI Input terminal value (typ)

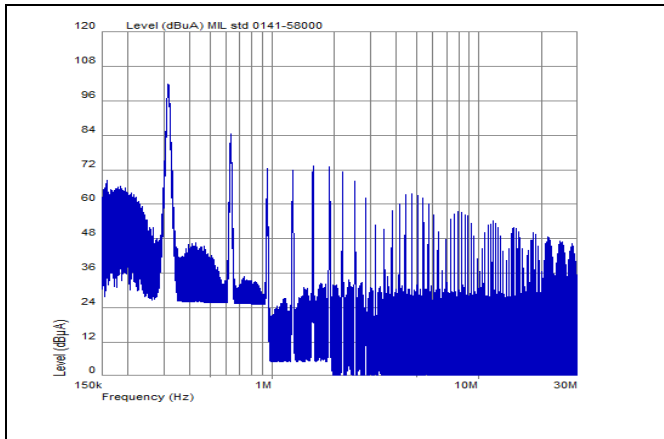

EMI without filter

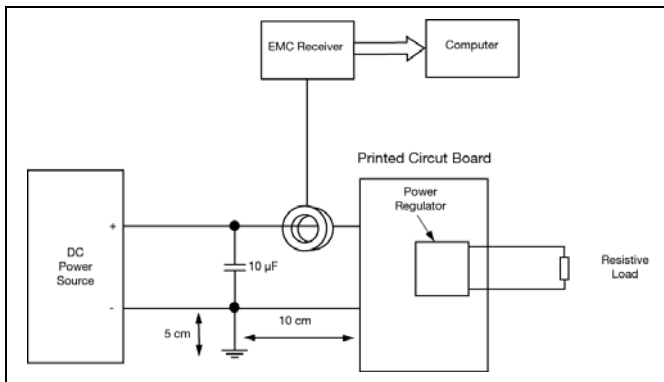

Test set-up

Layout Recommendations

The radiated EMI performance of the product will depend on the PWB layout and ground layer design. It is also important to consider the stand-off of the product. If a ground layer is used, it should be connected to the output of the product and the equipment ground or chassis.
 A ground layer will increase the stray capacitance in the PWB and improve the high frequency EMC performance.

Output Ripple and Noise

Output ripple and noise measured according to figure below. A 50 mm conductor works as a small inductor forming together with the two capacitances a damped filter.

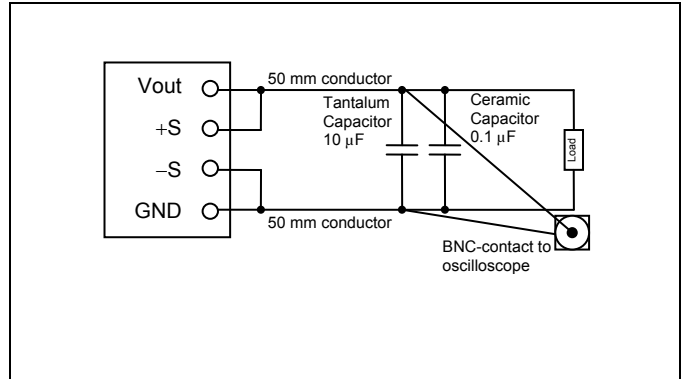

Output ripple and noise test set-up. Additional $C_O = 470 \mu F$ was added close to the output pins.

Operating information

Power Management Overview

This product is equipped with a PMBus interface. The product incorporates a wide range of readable and configurable power management features that are simple to implement with a minimum of external components. Additionally, the product includes protection features that continuously safeguard the load from damage due to unexpected system faults. A fault is also shown as an alert on the SALERT pin. The following product parameters can continuously be monitored by a host: Input voltage, output voltage/current, and internal temperature. If the monitoring is not needed it can be disabled and the product enters a low power mode reducing the power consumption. The protection features are not affected.

The product is delivered with a default configuration suitable for a wide range operation in terms of input voltage, output voltage, and load. The configuration is stored in an internal Non-Volatile Memory (NVM). All power management functions can be reconfigured using the PMBus interface. Please contact your local Ericsson Power Modules representative for design support of custom configurations or appropriate SW tools for design and down-load of your own configurations.

Input Voltage

The input voltage range, 4.5 - 14 V, makes the product easy to use in intermediate bus applications when powered by a non-regulated bus converter or a regulated bus converter. See Ordering Information for input voltage range.

BMR 463 series POL Regulators
 Input 4.5-14 V, Output up to 20 A / 66 W

EN/LZT 146 434 R1A January 2011

© Ericsson AB

Input Under Voltage Lockout, UVLO

The product monitors the input voltage and will turn-on and turn-off at configured levels. The default turn-on input voltage level setting is 4.20 V, whereas the corresponding turn-off input voltage level is 3.85 V. Hence, the default hysteresis between turn-on and turn-off input voltage is 0.35 V. Once an input turn-off condition occurs, the device can respond in a number of ways as follows:

1. Continue operating without interruption. The unit will continue to operate as long as the input voltage can be supported. If the input voltage continues to fall, there will come a point where the unit will cease to operate.
2. Continue operating for a given delay period, followed by shutdown if the fault still exists. The device will remain in shutdown until instructed to restart.
3. Initiate an immediate shutdown until the fault has been cleared. The user can select a specific number of retry attempts.

The default response from a turn-off is an immediate shutdown of the device. The device will continuously check for the presence of the fault condition. If the fault condition is no longer present, the product will be re-enabled. The turn-on and turn-off levels and response can be reconfigured using the PMBus interface.

Remote Control

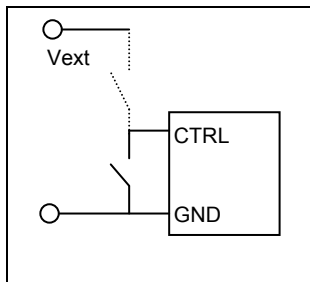

The product is equipped with a remote control function, i.e., the CTRL pin. The remote control can be connected to either the primary negative input connection (GND) or an external voltage (Vext), which is a 3 - 5 V positive supply voltage in accordance to the SMBus Specification version 2.0.

The CTRL function allows the product to be turned on/off by an external device like a semiconductor or mechanical switch. By default the product will turn on when the CTRL pin is left open and turn off when the CTRL pin is applied to GND. The CTRL pin has an internal pull-up resistor. The maximum required sink current is 0.5 mA. When the CTRL pin is left open, the voltage generated on the CTRL pin is max 6 V.

The product can also be configured using the PMBus interface to be "Always on", i.e., starts immediately when an appropriate input voltage is applied, or turn on/off can be performed with PMBus commands.

Input and Output Impedance

The impedance of both the input source and the load will interact with the impedance of the product. It is important that the input source has low characteristic impedance. The performance in some applications can be enhanced by addition of external capacitance as described under External Decoupling Capacitors. If the input voltage source contains significant inductance, the addition a capacitor with low ESR at the input of the product will ensure stable operation.

External Decoupling Capacitors

Input capacitors:

The input ripple RMS current in a buck converter is equal to

$$\text{Eq. 1. } I_{inputRMS} = I_{load} \sqrt{D(1-D)},$$

where I_{load} is the output load current and D is the duty cycle.

The maximum load ripple current becomes $I_{load}/2$. The ripple current is divided into three parts, i.e., currents in the input source, external input capacitor, and internal input capacitor. How the current is divided depends on the impedance of the input source, ESR and capacitance values in the capacitors. A minimum capacitance of 300 μ F with low ESR is recommended. The ripple current rating of the capacitors must follow Eq. 1. For high-performance/transient applications or wherever the input source performance is degraded, additional low ESR ceramic type capacitors at the input is recommended. The additional input low ESR capacitance above the minimum level insures an optimized performance.

Output capacitors:

When powering loads with significant dynamic current requirements, the voltage regulation at the point of load can be improved by addition of decoupling capacitors at the load. The most effective technique is to locate low ESR ceramic and electrolytic capacitors as close to the load as possible, using several capacitors in parallel to lower the effective ESR. The ceramic capacitors will handle high-frequency dynamic load changes while the electrolytic capacitors are used to handle low frequency dynamic load changes. Ceramic capacitors will also reduce high frequency noise at the load.

It is equally important to use low resistance and low inductance PWB layouts and cabling.

External decoupling capacitors are a part of the control loop of the product and may affect the stability margins.

Stable operation is guaranteed for the following total capacitance C_o in the output decoupling capacitor bank where

$$\text{Eq. 2. } C_o = [C_{min}, C_{max}] = [300, 15000] \mu\text{F.}$$

The decoupling capacitor bank should consist of capacitors which has a capacitance value larger than $C \geq C_{min}$ and has an ESR range of

$$\text{Eq. 3. } ESR = [ESR_{min}, ESR_{max}] = [5, 30] \text{ m}\Omega$$

The control loop stability margins are limited by the minimum time constant τ_{min} of the capacitors. Hence, the time constant of the capacitors should follow Eq. 4.

BMR 463 series POL Regulators
Input 4.5-14 V, Output up to 20 A / 66 W

EN/LZT 146 434 R1A January 2011

© Ericsson AB

Eq. 4. $\tau \geq \tau_{min} = C_{min} ESR_{min} = 1.5 \mu s$

This relation can be used if your preferred capacitors have parameters outside the above stated ranges in Eq. 2 and Eq.3.

- If the capacitors capacitance value is $C < C_{min}$ one must use at least N capacitors where

$$N \geq \left\lceil \frac{C_{min}}{C} \right\rceil \text{ and } ESR \geq ESR_{min} \frac{C_{min}}{C} .$$

- If the ESR value is $ESR > ESR_{max}$ one must use at least N capacitors of that type where

$$N \geq \left\lceil \frac{ESR}{ESR_{max}} \right\rceil \text{ and } C \geq \frac{C_{min}}{N} .$$

- If the ESR value is $ESR < ESR_{min}$ the capacitance value should be

$$C \geq C_{min} \frac{ESR_{min}}{ESR} .$$

For a total capacitance outside the above stated range or capacitors that do not follow the stated above requirements above a re-design of the control loop parameters will be necessary for robust dynamic operation and stability.

Control Loop Compensation

The product is configured with a robust control loop compensation which allows for a wide range operation of input and output voltages and capacitive loads as defined in the section External Decoupling Capacitors. For an application with a specific input voltage, output voltage, and capacitive load, the control loop can be optimized for a robust and stable operation and with an improved load transient response. This optimization will minimize the amount of required output decoupling capacitors for a given load transient requirement yielding an optimized cost and minimized board space. The control loop parameters can be reconfigured using the PMBus interface.

Load Transient Response Optimization

The product incorporates a Non-Linear transient Response, NLR, loop that decreases the response time and the output voltage deviation during a load transient. The NLR results in a higher equivalent loop bandwidth than is possible using a traditional linear control loop. The product is pre-configured with appropriate NLR settings for robust and stable operation for a wide range of input voltage and a capacitive load range as defined in the section External Decoupling Capacitors. For an application with a specific input voltage, output voltage, and capacitive load, the NLR configuration can be optimized for a robust and stable operation and with an improved load transient response. This will also reduce the amount of output decoupling capacitors and yield a reduced cost. However, the NLR reduces the energy efficiency. In order to obtain maximal energy efficiency the load transient requirement has to be met by the standard control loop compensation and the decoupling capacitors. The NLR settings can be reconfigured using the PMBus interface.

Remote Sense

The product has remote sense that can be used to compensate for voltage drops between the output and the point of load. The sense traces should be located close to the PWB ground layer to reduce noise susceptibility. The remote sense circuitry will compensate for up to 0.3 V voltage drop between output pins and the point of load. If the remote sense is not needed +S should be connected to VOUT and -S should be connected to GND.

Output Voltage Adjust using Pin-strap Resistor

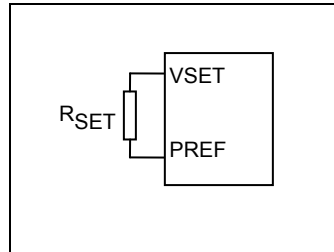

Using an external Pin-strap resistor, R_{SET} , the output voltage can be set in the range 0.6 V to 3.3 V at 28 different levels shown in the table below. The resistor should be applied between the VSET pin and the PREF pin.

R_{SET} also sets the maximum output voltage, see section Limiting the maximum output voltage. The resistor is sensed only during product boot-up. Changing the resistor value during normal operation will not change the output voltage. The input voltage must be at least 1 V larger than the output voltage in order to deliver the correct output voltage. See Ordering Information for output voltage range.

The following table shows recommended resistor values for R_{SET} (1% tolerance resistors suggested).

V_{OUT} [V]	R_{SET} [kΩ]	V_{OUT} [V]	R_{SET} [kΩ]
0.60	10	1.50	46.4
0.65	11	1.60	51.1
0.70	12.1	1.70	56.2
0.75	13.3	1.80	61.9
0.80	14.7	1.90	68.1
0.85	16.2	2.00	75
0.90	17.8	2.10	82.5
0.95	19.6	2.20	90.9
1.00	21.5	2.30	100
1.05	23.7	2.50	110
1.10	26.1	3.00	121
1.15	28.7	3.30	133
1.20	31.6		
1.25	34.8		
1.30	38.3		
1.40	42.2		

BMR 463 series POL Regulators
 Input 4.5-14 V, Output up to 20 A / 66 W

EN/LZT 146 434 R1A January 2011

© Ericsson AB

The output voltage and the maximum output voltage can be pin strapped to three fixed values by connecting the VSET pin according to the table below.

V_{OUT} [V]	VSET
0.60	Shorted to PREF
1.2	Open "high impedance"
2.5	Logic High, GND as reference

Output Voltage Adjust using PMBus

The output voltage of the product can be configured using the PMBus interface in the range 0.54 to 3.63. See Ordering Information for output voltage range.

Limiting the maximum output voltage

The product can be configured for maximum output voltage protection. The output voltage pin-strap resistor R_{SET} also sets the maximum output voltage equal to 110% of the nominal output value, $V_{OUTMAX} = 1.1 \times V_{OUT}$. A PMBus command can not set the nominal output voltage higher than V_{OUTMAX} . This protects the load from an over voltage due to an accidental wrong PMBus command.

Over Voltage Protection (OVP)

The product includes over voltage limiting circuitry for protection of the load. The default OVP limit is 15% above the nominal output voltage. If the output voltage exceeds the OVP limit, the product can respond in different ways:

1. Initiate an immediate shutdown until the fault has been cleared. The user can select a specific number of retry attempts.
2. Turn off the high-side MOSFET and turn on the low-side MOSFET. The low-side MOSFET remains ON until the device attempts a restart, i.e. the output voltage is pulled to ground level (crowbar function).

The default response from an overvoltage fault is to immediately shut down as in 2. The device will continuously check for the presence of the fault condition, and when the fault condition no longer exists the device will be re-enabled. For continuous OVP when operating from an external clock for synchronization, the only allowed response is an immediate shutdown. The OVP limit and fault response can be reconfigured using the PMBus interface.

Under Voltage Protection (UVP)

The product includes output under voltage limiting circuitry for protection of the load. The default UVP limit is 15% below the nominal output voltage. The UVP limit can be reconfigured using the PMBus interface.

Power Good

The product provides a Power Good (PG) signal as a flag in the Status Word register that indicates the output voltage is within a specified tolerance of its target level and no fault condition exists. By default, the PG signal will be asserted if

the output is within -10%/+15% of the target voltage. These limits may be changed via the PMBus interface. A PG delay period is defined as the time from when all conditions within the product for asserting PG are met to when the PG signal is actually asserted. By default, the PG delay is set equal to the soft-start ramp time setting. Therefore, if the soft-start ramp time is set to 10 ms, the PG delay will be set to 10 ms. The PG delay may be set independently of the soft-start ramp using the PMBus interface.

Switching Frequency

The fundamental switching frequency f_{PROG} is 320 kHz, which yields optimal power efficiency. The switching frequency can be set to any value between 200 kHz and 640 kHz using the PMBus interface. The switching frequency will change the efficiency/power dissipation, load transient response and output ripple. For optimal control loop performance the control loop must be re-designed when changing the switching frequency.

Synchronization

Synchronization is a feature that allows multiple products to be synchronized to a common frequency. Synchronized products powered from the same bus eliminate beat frequencies reflected back to the input supply, and also reduces EMI filtering requirements. Eliminating the slow beat frequencies (usually <10 kHz) allows the EMI filter to be designed to attenuate only the synchronization frequency. Synchronization can also be utilized for phase spreading, described in section Phase Spreading.

The products can be synchronized with an external oscillator or one product can be configured with the SYNC pin as a SYNC Output working as a master driving the synchronization. All others on the same synchronization bus should be configured with SYNC Input or SYNC Auto Detect (Default configuration) for correct operation. When the SYNC pin is configured in auto detect mode the product will automatically check for a clock signal on the SYNC pin.

Phase Spreading

When multiple products share a common DC input supply, spreading of the switching clock phase between the products can be utilized. This dramatically reduces input capacitance requirements and efficiency losses, since the peak current drawn from the input supply is effectively spread out over the whole switch period. This requires that the products are synchronized. Up to 16 different phases can be used. The phase spreading of the product can be configured using the PMBus interface.

Parallel Operation (Current Sharing)

Paralleling multiple products can be used to increase the output current capability of a single power rail. By connecting the GCB pins of each device and configuring the devices as a current sharing rail, the units will share the current equally within a few percent. Enabling up to 100% utilization of the current capability for each device in the current sharing rail. The product uses a low-bandwidth, first-order digital current sharing technique to balance the unequal device output

BMR 463 series POL Regulators Input 4.5-14 V, Output up to 20 A / 66 W	EN/LZT 146 434 R1A January 2011
	© Ericsson AB

loading by aligning the load lines of slave devices to a master device. Artificial droop resistance is added to the output voltage path to control the slope of the load line curve, calibrating out the physical parasitic mismatches due to power train components and PWB layout. Up to 8 devices can be configured in a given current sharing group.

During periods of light loading, it may be beneficial to disable one or more phases in order to eliminate the current drain and switching losses associated with those phases, resulting in higher efficiency. The product offers the ability to add and drop phases using a PMBus command in response to an observed load current change. All phases in a current share rail are considered active prior to the current sharing rail ramp to power-good. Phases can be dropped after power-good is reached. Any member of the current sharing rail can be dropped. If the reference device is dropped, the remaining active device with the lowest member position will become the new reference. Additionally, any change to the number of members of a current sharing rail will precipitate autonomous phase distribution within the rail where all active phases realign their phase position based on their order within the number of active members. If the members of a current sharing rail are forced to shut down due to an observed fault, all members of the rail will attempt to re-start simultaneously after the fault has cleared.

Adaptive Diode Emulation

Most power converters use synchronous rectification to optimize efficiency over a wide range of input and output conditions. However, at light loads the synchronous MOSFET will typically sink current and introduce additional energy losses associated with higher peak inductor currents, resulting in reduced efficiency. Adaptive diode emulation mode turns off the low-side FET gate drive at low load currents to prevent the inductor current from going negative, reducing the energy losses and increasing overall efficiency. Diode emulation is not available for current sharing groups. Note: the overall bandwidth of the product may be reduced when in diode emulation mode. It is recommended that diode emulation is disabled prior to applying significant load steps. The diode emulation mode can be configured using the PMBus interface.

Adaptive Frequency and Pulse Skip Control

Since switching losses contribute to the efficiency of the power converter, reducing the switching frequency will reduce the switching losses and increase efficiency. The product includes an Adaptive Frequency Control mode, which effectively reduces the observed switching frequency as the load decreases. Adaptive frequency mode is only available while the device is operating within Adaptive Diode Emulation Mode. As the load current is decreased, diode emulation mode decreases the Synch-FET on-time to prevent negative inductor current from flowing. As the load is decreased further, the Switch-FET pulse width will begin to decrease while maintaining the programmed frequency, f_{PROG} (set by the `FREQ_SWITCH` command). Once the Switch-FET pulse width (D) reaches 50% of the nominal duty cycle, D_{NOM} (determined by V_I and V_O), the switching frequency will start to decrease according to the following equation:

$$\text{Eq. 5. } f_{sw} = D \left(\frac{2(f_{PROG} - f_{MIN})}{D_{NOM}} \right) + f_{MIN} .$$

Disabling a minimum Synch-FET makes the product also pulse skip which reduces the power loss further. It should be noted that adaptive frequency mode is not available for current sharing groups and is not allowed when the device is placed in auto-detect mode and a clock source is present on the SYNC pin, or if the device is outputting a clock signal on its SYNC pin. The adaptive frequency and pulse skip modes can be configured using the PMBus interface.

Efficiency Optimized Dead Time Control

The product utilizes a closed loop algorithm to optimize the dead-time applied between the gate drive signals for the switch and synch FETs. The algorithm constantly adjusts the deadtime non-overlap to minimize the duty cycle, thus maximizing efficiency. This algorithm will null out deadtime differences due to component variation, temperature and loading effects. The algorithm can be configured via the PMBus interface.

Over Current Protection (OCP)

The product includes current limiting circuitry for protection at continuous overload. The following OCP response options are available:

1. Initiate a shutdown and attempt to restart an infinite number of times with a preset delay period between attempts.
2. Initiate a shutdown and attempt to restart a preset number of times with a preset delay period
3. Continue operating for a given delay period, followed by shutdown if the fault still exists.
4. Continue operating through the fault (this could result in permanent damage to the product).
5. Initiate an immediate shutdown.

The default response from an over current fault is an immediate shutdown of the device. The device will continuously check for the presence of the fault condition, and if the fault condition no longer exists the device will be re-enabled. The load distribution should be designed for the maximum output short circuit current specified. The OCP limit and response of the product can be reconfigured using the PMBus interface.

Note.

When the ratio V_O/V_I is higher than 0.66 (e.g. $V_I = 4.5$ V and $V_O = 3.3$ V), and with the current sense configuration according to factory default, the current limit threshold will be above specified maximum value. To achieve the specified current limit threshold, the current sense configuration should be changed to "up slope sensing". This is configured by using the PMBus interface.

BMR 463 series POL Regulators
 Input 4.5-14 V, Output up to 20 A / 66 W

EN/LZT 146 434 R1A January 2011

© Ericsson AB

Soft-start Power Up

The soft-start control introduces a time-delay (default setting 10 ms) before allowing the output voltage to rise. The default rise time of the ramp up is 10 ms. Power-up is hence completed within 20 ms in default configuration using remote control. When starting by applying input voltage the control circuit boot-up time adds an additional ~25 ms delay. The soft-start power up of the product can be reconfigured using the PMBus interface.

Output Voltage Sequencing

A group of products may be configured to power up in a predetermined sequence. This feature is especially useful when powering advanced processors, FPGAs, and ASICs that require one supply to reach its operating voltage prior to another. Multi-product sequencing can be achieved by configuring the start delay and rise time of each device through the PMBus interface and by using the CTRL start signal.

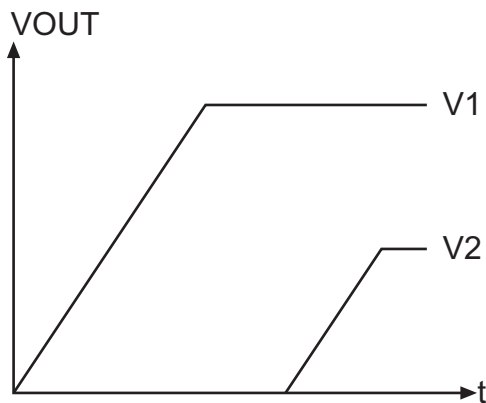

Illustration of Output Voltage Sequencing.

Voltage Tracking

The product integrates a lossless tracking scheme that allows its output to track a voltage that is applied to the VTRK pin with no external components required. During ramp-up, the output voltage follows the VTRK voltage until the preset output voltage level is met. The product offers two modes of tracking as follows:

1. Coincident. This mode configures the product to ramp its output voltage at the same rate as the voltage applied to the VTRK pin.

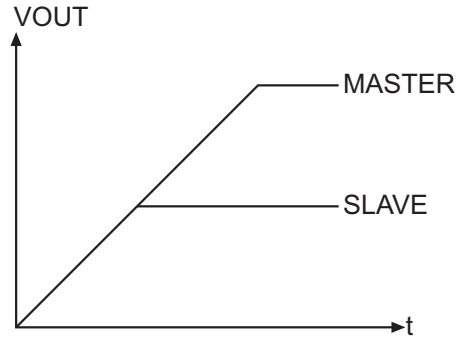

Illustration of Coincident Voltage Tracking.

2. Ratiometric. This mode configures the product to ramp its output voltage at a rate that is a percentage of the voltage applied to the VTRK pin. The default setting is 50%, but a different tracking ratio may be set by an external resistive voltage divider or through the PMBus interface.

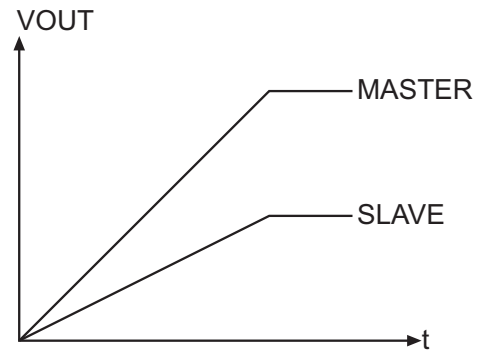

Illustration of Ratiometric Voltage Tracking

The master device in a tracking group is defined as the device that has the highest target output voltage within the group. This master device will control the ramp rate of all tracking devices and is not configured for tracking mode. All of the CTRL pins in the tracking group must be connected and driven by a single logic source. It should be noted that current sharing groups that are also configured to track another voltage do not offer pre-bias protection; a minimum load should therefore be enforced to avoid the output voltage from being held up by an outside force.

BMR 463 series POL Regulators Input 4.5-14 V, Output up to 20 A / 66 W	EN/LZT 146 434 R1A January 2011
	© Ericsson AB

Voltage Margining Up/Down

The product can adjust its output higher or lower than its nominal voltage setting in order to determine whether the load device is capable of operating over its specified supply voltage range. This provides a convenient method for dynamically testing the operation of the load circuit over its supply margin or range. It can also be used to verify the function of supply voltage supervisors. Margin limits of the nominal output voltage $\pm 5\%$ are default, but the margin limits can be reconfigured using the PMBus interface to as high as 10% or as low as 0 V.

Pre-Bias Startup Capability

Pre-bias startup often occurs in complex digital systems when current from another power source is fed back through a dual-supply logic component, such as FPGAs or ASICs. The BMR463 product family incorporates synchronous rectifiers, but will not sink current during startup, or turn off, or whenever a fault shuts down the product in a pre-bias condition. Pre-bias protection is not offered for current sharing groups that also have voltage tracking enabled.

Group Communication Bus

The Group Communication Bus, GCB bus, is used to communicate between products. This dedicated bus provides the communication channel between devices for features such as sequencing, fault spreading, and current sharing. The GCB bus solves the PMBus data rate limitation. The GCB pin on all devices in an application should be connected. A pull-up resistor is required on the GCB bus order to guarantee the rise time as follows:

$$\text{Eq. 6 } \tau = R_{GCB} C_{GCB} = 1\mu\text{s},$$

where R_{GCB} is the pull up resistor value and C_{GCB} is the bus loading. The pull-up resistor should be tied to an external 3.3 V or 5 V supply voltage, which should be present prior to or during power-up.

Fault spreading

The product can be configured to broadcast a fault event over the GCB bus to the other devices in the group. When a non-destructive fault occurs and the device is configured to shut down on a fault, the device will shut down and broadcast the fault event over the GCB bus. The other devices on the GCB bus will shut down together if configured to do so, and will attempt to re-start in their prescribed order if configured to do so.

Over Temperature Protection (OTP)

The products are protected from thermal overload by an internal over temperature shutdown circuit. When T_{P1} as defined in thermal consideration section exceeds 120°C the product will shut down. The product will make continuous attempts to start up and resume normal operation automatically when the temperature has dropped $>15^\circ\text{C}$ below the temperature threshold. The OTP level, hysteresis, and fault response of the product can be reconfigured using the PMBus interface. The fault response can be configured as follows:

1. Initiate a shutdown and attempt to restart an infinite number of times with a preset delay period between attempts (default configuration).
2. Initiate a shutdown and attempt to restart a preset number of times with a preset delay period between attempts.
3. Continue operating for a given delay period, followed by shutdown if the fault still exists.
4. Continue operating through the fault (this could result in permanent damage to the power supply).
5. Initiate an immediate shutdown.

Thermal Consideration**General**

The product is designed to operate in different thermal environments and sufficient cooling must be provided to ensure reliable operation.

Cooling is achieved mainly by conduction, from the pins to the host board, and convection, which is dependant on the airflow across the product. Increased airflow enhances the cooling of the product.

The Output Current Derating graph found in the Output section for each model provides the available output current vs. ambient air temperature and air velocity at specified V_i .

The products with an output power $\geq 100\text{ W}$ are tested on a 254 x 254 mm, 35 μm (1 oz), 16-layer test board, and for output power $< 100\text{ W}$ a 254 x 254 mm, 35 μm (1 oz), 8-layer test board is used. The test board is mounted vertically in a wind tunnel with a cross-section of 608 x 203 mm.

Proper cooling of the product can be verified by measuring the temperature at positions P1 and P2. The temperature at these positions should not exceed the max values provided in the table below.

Note that the max value is the absolute maximum rating (non destruction) and that the electrical Output data is guaranteed up to $T_{P1} + 85^\circ\text{C}$.

See Design Note 019 for further information.

BMR 463 series POL Regulators
 Input 4.5-14 V, Output up to 20 A / 66 W

EN/LZT 146 434 R1A January 2011

© Ericsson AB

Definition of product operating temperature

The product operating temperatures are used to monitor the temperature of the product, and proper thermal conditions can be verified by measuring the temperature at positions P1 and P2. The temperature at these positions (T_{P1} , T_{P2}) should not exceed the maximum temperatures in the table below. The number of measurement points may vary with different thermal design and topology. Temperatures above maximum T_{P1} , measured at the reference point P1 are not allowed and may cause permanent damage.

Position	Description	Max Temp.
P1	Reference point, L1, inductor	120° C
P2	N1, control circuit	120° C

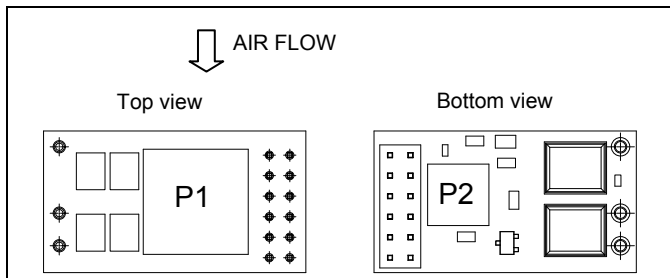

Temperature positions and air flow direction.

Definition of reference temperature T_{P1}

The reference temperature is used to monitor the temperature limits of the product. Temperature above maximum T_{P1} , measured at the reference point P1 is not allowed and may cause degradation or permanent damage to the product. T_{P1} is also used to define the temperature range for normal operating conditions. T_{P1} is defined by the design and used to guarantee safety margins, proper operation and high reliability of the product.

Connections

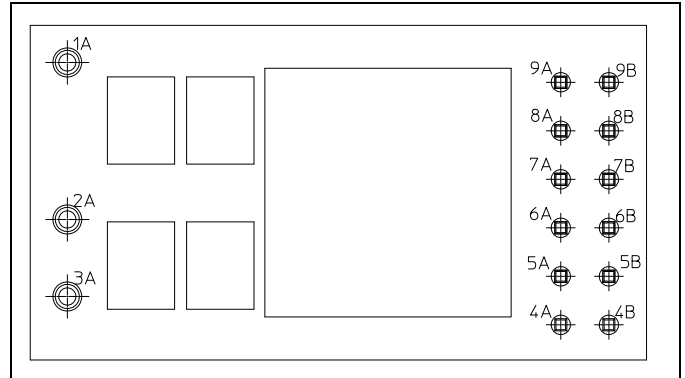

Pin layout, top view.

Pin	Designation	Function
1A	VIN	Input Voltage
2A	GND	Power Ground
3A	VOOUT	Output Voltage
4A	VTRK	Voltage Tracking input
4B	PREF	Pin-strap reference
5A	+S	Positive sense
5B	-S	Negative sense
6A	SA0	PMBus address pinstrap
6B	GCB	Group Communication Bus
7A	SCL	PMBus Clock
7B	SDA	PMBus Data
8A	VSET	Output voltage pinstrap
8B	SYNC	Synchronization I/O
9A	SALERT	PMBus Alert
9B	CTRL	Remote Control

PWB layout considerations

The pinstrap resistors, R_{set} , and R_{SA0} should be placed as close to the product as possible to minimize loops that may pick up noise. Avoid current carrying planes under the pinstrap resistors and the PMBus signals. The capacitor C_1 (or capacitors implementing it) should be placed as close to the input pins as possible. Capacitor C_0 (or capacitors implementing it) should be placed close to the load.

BMR 463 series POL Regulators
 Input 4.5-14 V, Output up to 20 A / 66 W

EN/LZT 146 434 R1A January 2011

© Ericsson AB

Typical Application Circuit

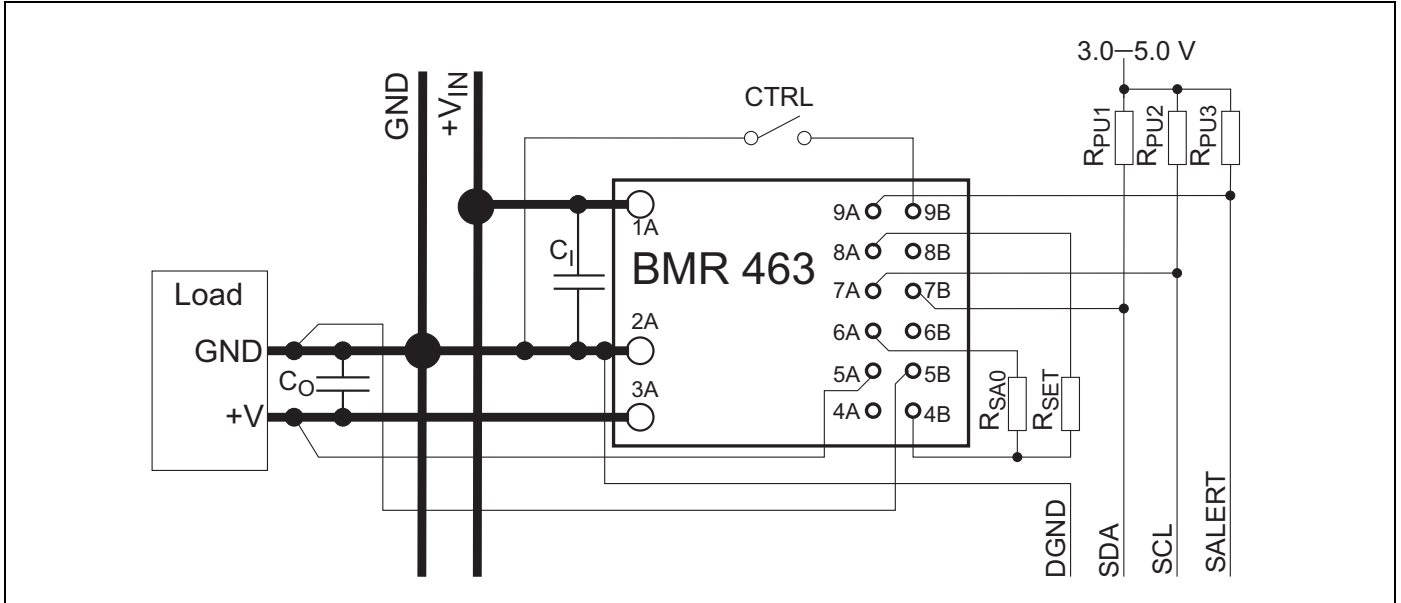

Standalone with PMBus communication

BMR 463 series POL Regulators
 Input 4.5-14 V, Output up to 20 A / 66 W

EN/LZT 146 434 R1A January 2011

© Ericsson AB

PMBus Interface

This product provides a PMBus digital interface that enables the user to configure many aspects of the device operation as well as to monitor the input and output voltages, output current and device temperature. The product can be used with any standard two-wire I²C or SMBus host device. In addition, the module is compatible with PMBus version 1.1 and includes an SALERT line to help mitigate bandwidth limitations related to continuous fault monitoring. The product supports both 100 kHz and 400 kHz bus clock frequency. The PMBus signals, SCL, SDA and SALERT require passive pull-up resistors as stated in the SMBus Specification. Pull-up resistors is required to guarantee the rise time as follows:

$$\text{Eq. 7} \quad \tau = R_p C_p = 1\mu\text{s}$$

where R_p is the pull-up resistor value and C_p is the bus loading, the maximum allowed bus load is 400 pF. The pull-up resistor should be tied to an external 3.0 to 5.0 V $\pm 10\%$ supply voltage, which should be present prior to or during power-up.

Monitoring via PMBus

It is possible to monitor a wide variety of different parameters through the PMBus interface. Fault conditions can be monitored using the SALERT pin, which will be asserted when any number of pre-configured fault or warning conditions occur. It is also possible to continuously monitor one or more of the power conversion parameters including but not limited to the following:

- Input voltage
- Output voltage
- Output current
- Internal junction temperature
- Switching frequency
- Duty cycle

Snap Shot Parameter Capture

This product offers a special feature that enables the user to capture parametric data during normal operation or following a fault. The following parameters are stored:

- Input voltage
- Output voltage
- Output current
- Internal junction temperature
- Switching frequency
- Duty cycle
- Status registers

The Snapshot feature enables the user to read the parameters via the PMBus interface during normal operation, although it should be noted that reading the 22 bytes will occupy the bus for some time. The Snapshot enables the user to store the snapshot parameters to Flash memory in response to a pending fault as well as to read the stored data from Flash

memory after a fault has occurred. Automatic store to Flash memory following a fault is triggered when any fault threshold level is exceeded, provided that the specific fault response is to shut down. Writing to Flash memory is not allowed if the device is configured to re-try following the specific fault condition. It should also be noted that the device supply voltage must be maintained during the time the device is writing data to Flash memory; a process that requires between 700-1400 μs depending on whether the data is set up for a block write. Undesirable results may be observed if the input voltage of the modules drops below 3.0 V during this process

Software Tools for Design and Production

Ericsson provides software for configuration and monitoring of this product via the PMBus interface.

For more information please contact your local Ericsson sales representative.

PMBus addressing

The PMBus address should be configured with a resistor connected between the SA0 pin and the PREF pin, as shown in the figure below. Recommended resistor values for hard-wiring PMBus addresses (series E96, 1% tolerance resistors suggested) are shown in the table.

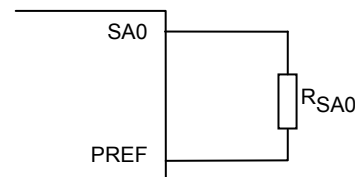

Schematic of connection of address resistor.

Index	R _{SA0} [kΩ]	Index	R _{SA0} [kΩ]
0	10	13	34.8
1	11	14	38.3
2	12.1	15	42.2
3	13.3	16	46.4
4	14.7	17	51.1
5	16.2	18	56.2
6	17.8	19	61.9
7	19.6	20	68.1
8	21.5	21	75
9	23.7	22	82.5
10	26.1	23	90.9
11	28.7	24	100
12	31.6		

BMR 463 series POL Regulators
 Input 4.5-14 V, Output up to 20 A / 66 W

EN/LZT 146 434 R1A January 2011

© Ericsson AB

The PMBus address follows the equation below:

Eq. 8 PMBus Address (decimal) = 75 + Index

This allows the use of 25 different PMBus addresses, yielding the decimal address range of 0d [75,K ,99]. However, the address 0d75 is allocated for production needs and can not be used. If more than 24 devices of this type are required on the same PMBus another address range is required. See Ordering Information for different PMBus address ranges. The user shall also be aware of further limitations of the address space as stated in the SMBus Specification.

Optional PMBus Addressing

The address space is increased by connecting the SA0 pin according to the following table.

SA0 R _{SA0} [kΩ]	Address
Shorted to PREF	0d33
Open "high impedance"	0d36
Logic High, GND as reference	0d39

Logic High definitions see Electrical Specification

I²C/SMBus Setup and Hold Times – Definitions

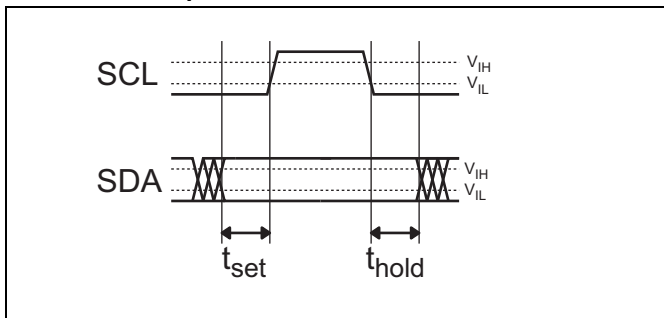

SMBus timing diagram

The setup time, t_{set} , is the time data, SDA, must be stable before the rising edge of the clock signal, SCL. The hold time t_{hold} , is the time data must be stable after the rising edge of the clock signal, SCL. If these times are violated incorrect data may be captured or meta-stability may occur and the bus communication may fail.

BMR 463 series POL Regulators
 Input 4.5-14 V, Output up to 20 A / 66 W

EN/LZT 146 434 R1A January 2011

© Ericsson AB

PMBus Commands

The product is PMBus compliant. The following table lists the implemented PMBus commands. For more detailed information see PMBus Power System Management Protocol Specification; Part I – General Requirements, Transport and Electrical Interface and PMBus Power System Management Protocol; Part II – Command Language.

Designation	Cmd	Impl
Standard PMBus Commands		
Control Commands		
PAGE	00h	No
OPERATION	01h	Yes
ON_OFF_CONFIG	02h	Yes
WRITE_PROTECT	10h	No
Output Commands		
VOUT_MODE (Read Only)	20h	Yes
VOUT_COMMAND	21h	Yes
VOUT_TRIM	22h	Yes
VOUT_CAL_OFFSET	23h	Yes
VOUT_MAX	24h	Yes
VOUT_MARGIN_HIGH	25h	Yes
VOUT_MARGIN_LOW	26h	Yes
VOUT_TRANSITION_RATE	27h	Yes
VOUT_DROOP	28h	Yes
MAX_DUTY	32h	Yes
FREQUENCY_SWITCH	33h	Yes
IOUT_CAL_GAIN	38h	Yes
IOUT_CAL_OFFSET	39h	Yes
VOUT_SCALE_LOOP	29h	No
VOUT_SCALE_MONITOR	2Ah	No
COEFFICIENTS	30h	No
Fault Limit Commands		
POWER_GOOD_ON	5Eh	Yes
VOUT_OV_FAULT_LIMIT	40h	Yes
VOUT_UV_FAULT_LIMIT	44h	Yes
IOUT_OC_FAULT_LIMIT	46h	Yes
IOUT_UC_FAULT_LIMIT	4Bh	Yes
OT_FAULT_LIMIT	4Fh	Yes
OT_WARN_LIMIT	51h	Yes
UT_WARN_LIMIT	52h	Yes
UT_FAULT_LIMIT	53h	Yes
VIN_OV_FAULT_LIMIT	55h	Yes
VIN_OV_WARN_LIMIT	57h	Yes

Designation	Cmd	Impl
VIN_UV_WARN_LIMIT	58h	Yes
VIN_UV_FAULT_LIMIT	59h	Yes
VOUT_OV_WARN_LIMIT	42h	No
VOUT_UV_WARN_LIMIT	43h	No
IOUT_OC_WARN_LIMIT	4Ah	No
Fault Response Commands		
VOUT_OV_FAULT_RESPONSE	41h	Yes
VOUT_UV_FAULT_RESPONSE	45h	Yes
OT_FAULT_RESPONSE	50h	Yes
UT_FAULT_RESPONSE	54h	Yes
VIN_OV_FAULT_RESPONSE	56h	Yes
VIN_UV_FAULT_RESPONSE	5Ah	Yes
IOUT_OC_FAULT_RESPONSE	47h	No
IOUT_UC_FAULT_RESPONSE	4Ch	No
Time setting Commands		
TON_DELAY	60h	Yes
TON_RISE	61h	Yes
TOFF_DELAY	64h	Yes
TOFF_FALL	65h	Yes
TON_MAX_FAULT_LIMIT	62h	No
Status Commands (Read Only)		
CLEAR_FAULTS	03h	Yes
STATUS_BYTE	78h	Yes
STATUS_WORD	79h	Yes
STATUS_VOUT	7Ah	Yes
STATUS_IOUT	7Bh	Yes
STATUS_INPUT	7Ch	Yes
STATUS_TEMPERATURE	7Dh	Yes
STATUS_CML	7Eh	Yes
Monitor Commands (Read Only)		
READ_VIN	88h	Yes
READ_VOUT	8Bh	Yes
READ_IOUT	8Ch	Yes
READ_TEMPERATURE_1	8Dh	Yes
READ_TEMPERATURE_2	8Eh	No
READ_FAN_SPEED_1	90h	No
READ_DUTY_CYCLE	94h	Yes
READ_FREQUENCY	95h	Yes
Identification Commands (Read Only)		
PMBUS_REVISION	98h	Yes
MFR_ID	99h	Yes

BMR 463 series POL Regulators
 Input 4.5-14 V, Output up to 20 A / 66 W

EN/LZT 146 434 R1A January 2011

© Ericsson AB

Designation	Cmd	Impl
MFR_MODEL	9Ah	Yes
MFR_REVISION	9Bh	Yes
MFR_LOCATION	9Ch	Yes
MFR_DATE	9Dh	Yes
MFR_SERIAL	9Eh	Yes
Group Commands		
INTERLEAVE	37h	Yes
Supervisory Commands		
STORE_DEFAULT_ALL	11h	Yes
RESTORE_DEFAULT_ALL	12h	Yes
STORE_USER_ALL	15h	No
RESTORE_USER_ALL	16h	No
Product Specific Commands		
Time Setting Commands		
POWER_GOOD_DELAY	D4h	Yes
Fault limit Commands		
IOUT_AVG_OC_FAULT_LIMIT	E7h	Yes
IOUT_AVG_UC_FAULT_LIMIT	E8h	Yes
Fault Response Commands		
MFR_IOUT_OC_FAULT_RESPONSE	E5h	Yes
MFR_IOUT_UC_FAULT_RESPONSE	E6h	Yes
OVUV_CONFIG	D8h	Yes
Configuration and Control Commands		
MFR_CONFIG	D0h	Yes
USER_CONFIG	D1h	Yes
MISC_CONFIG	E9h	Yes
PID_TAPS	D5h	Yes
PID_TAPS_ADAPT	F2h	Yes
INDUCTOR	D6h	Yes
NLR_CONFIG	D7h	Yes
TEMPCO_CONFIG	DCh	Yes
DEADTIME	DDh	Yes
DEADTIME_CONFIG	DEh	Yes
DEADTIME_MAX	BFh	Yes
SNAPSHOT	EAh	Yes
SNAPSHOT_CONTROL	F3h	Yes
DEVICE_ID	E4h	Yes
USER_DATA_00	B0h	Yes
Group Commands		
SEQUENCE	E0h	Yes
GCB_GROUP	E2h	Yes

Designation	Cmd	Impl
ISHARE_CONFIG	D2h	Yes
PHASE_CONTROL	F0h	Yes
Supervisory Commands		
PRIVATE_PASSWORD	FBh	Yes
PUBLIC_PASSWORD	FCh	Yes
UNPROTECT	FDh	Yes
SECURITY_LEVEL	FAh	Yes

Notes:

Cmd is short for Command.

Impl is short for Implemented.

BMR 463 series POL Regulators
 Input 4.5-14 V, Output up to 20 A / 66 W

EN/LZT 146 434 R1A January 2011

© Ericsson AB

Mechanical Information – Through hole mount version

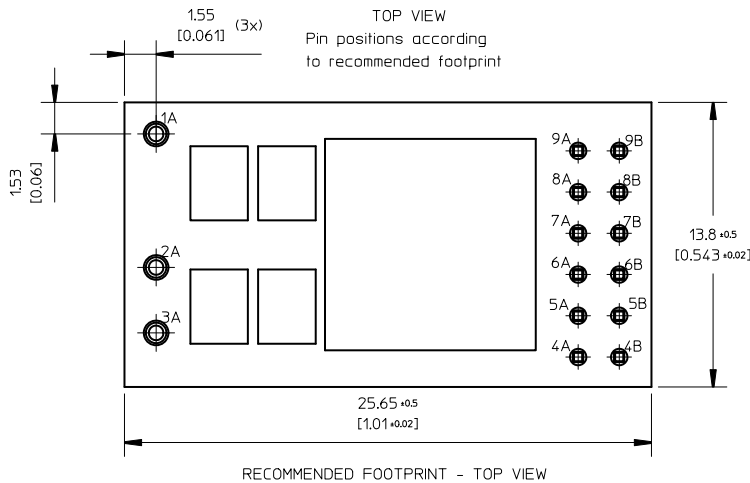
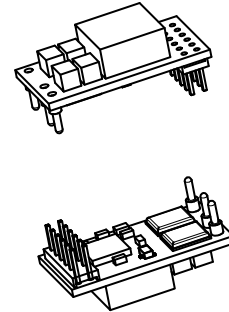
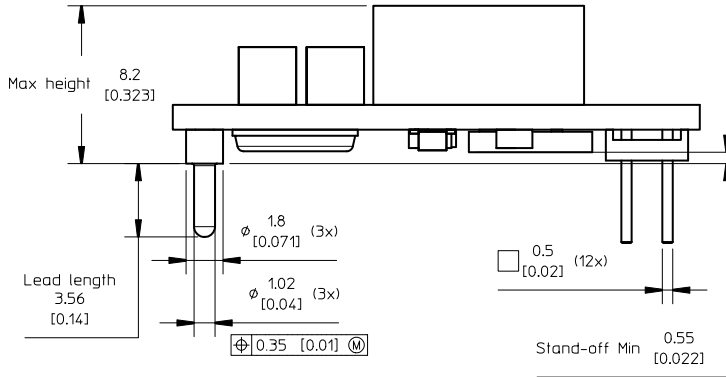

PIN SPECIFICATIONS

Pin 1A-3A Material: Copper alloy
 Plating: Min Matte tin 8-13 μm over 2.5-5 μm Ni
 Pin 4A-9B Material: Brass
 Plating: Min Au 0.2 μm over 1.27 μm Ni

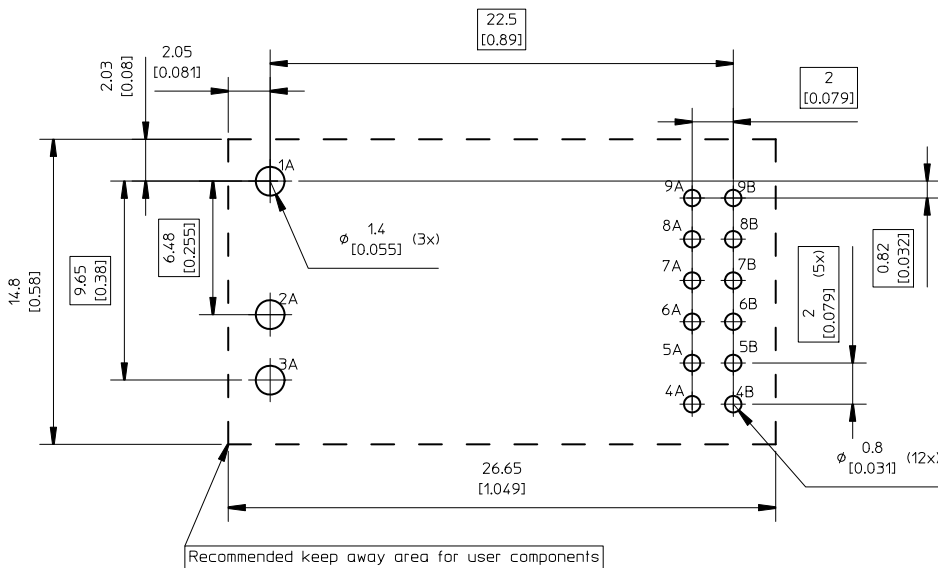

Weight: Typical 5.6 g
 All dimensions in mm [inch].
 Tolerances unless specified:
 x.x \pm 0.50 mm [0.02].
 x.xx \pm 0.25 mm [0.01]
 (not applied on footprint or typical values)



BMR 463 series POL Regulators
 Input 4.5-14 V, Output up to 20 A / 66 W

EN/LZT 146 434 R1A January 2011

© Ericsson AB

Mechanical Information – Surface Mount Version

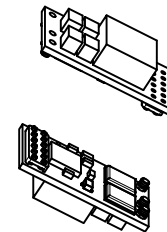
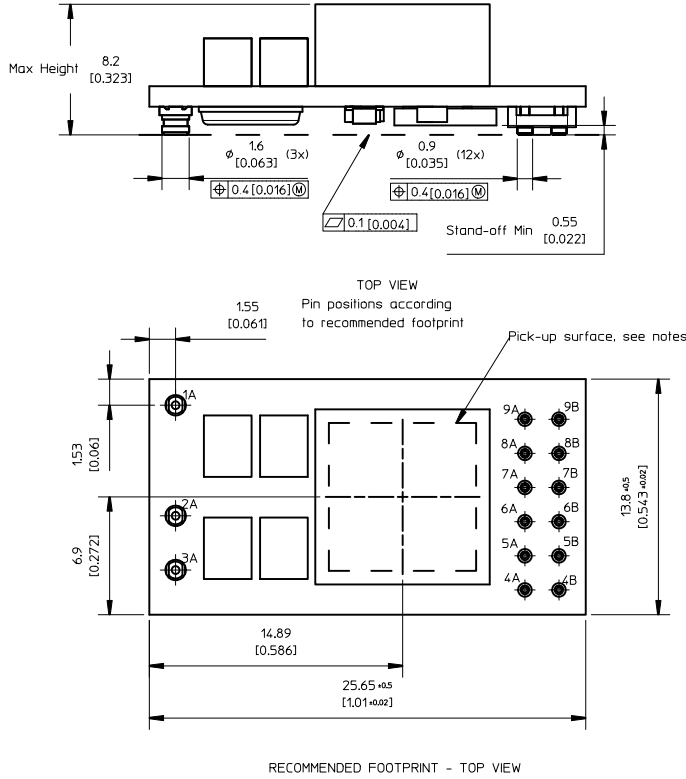

NOTES

- PIN SPECIFICATIONS**
 Pin 1A-3A Material: Copper alloy
 Plating: Au 0.1 μ m over 1-3 μ m Ni.
 Pin 4A-9B Material: Brass
 Plating: Au 0.1 μ m over 2 μ m Ni.
- PICK-UP SURFACE**
 Recommended pick-up nozzle size for assigned pick-up area is maximum $\text{\textcircled{O}}8$ [0.315].

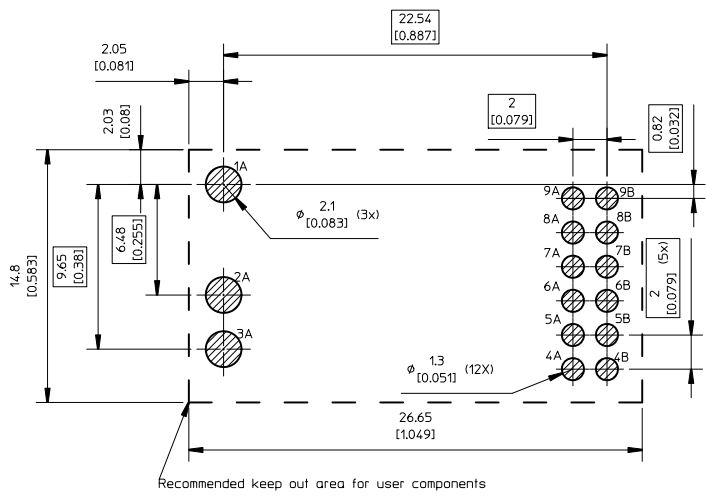

Weight: Typical 5.6 g
 All dimensions in mm [inch].
 Tolerances unless specified:
 x.x +0.50 [0.02]
 x.xx±0.25 [0.01]
 (not applied on footprint or typical values)



All component placements – whether shown as physical components or symbolical outline – are for reference only and are subject to change throughout the product's life cycle, unless explicitly described and dimensioned in this drawing.

BMR 463 series POL Regulators
 Input 4.5-14 V, Output up to 20 A / 66 W

EN/LZT 146 434 R1A January 2011

© Ericsson AB

Soldering Information - Surface Mounting

The surface mount product is intended for forced convection or vapor phase reflow soldering in SnPb or Pb-free processes.

The reflow profile should be optimised to avoid excessive heating of the product. It is recommended to have a sufficiently extended preheat time to ensure an even temperature across the host PCB and it is also recommended to minimize the time in reflow.

A no-clean flux is recommended to avoid entrapment of cleaning fluids in cavities inside the product or between the product and the host board, since cleaning residues may affect long time reliability and isolation voltage.

Minimum Pin Temperature Recommendations

Pin number 2A chosen as reference location for the minimum pin temperature recommendation since this will likely be the coolest solder joint during the reflow process.

SnPb solder processes

For SnPb solder processes, a pin temperature (T_{PIN}) in excess of the solder melting temperature, (T_L , 183°C for Sn63Pb37) for more than 30 seconds and a peak temperature of 210°C is recommended to ensure a reliable solder joint.

For dry packed products only: depending on the type of solder paste and flux system used on the host board, up to a recommended maximum temperature of 245°C could be used, if the products are kept in a controlled environment (dry pack handling and storage) prior to assembly.

Lead-free (Pb-free) solder processes

For Pb-free solder processes, a pin temperature (T_{PIN}) in excess of the solder melting temperature (T_L , 217 to 221°C for SnAgCu solder alloys) for more than 30 seconds and a peak temperature of 235°C on all solder joints is recommended to ensure a reliable solder joint.

Maximum Product Temperature Requirements

Top of the product PCB near pin 4B is chosen as reference location for the maximum (peak) allowed product temperature ($T_{PRODUCT}$) since this will likely be the warmest part of the product during the reflow process.

SnPb solder processes

For SnPb solder processes, the product is qualified for MSL 1 according to IPC/JEDEC standard J-STD-020C.

During reflow $T_{PRODUCT}$ must not exceed 225 °C at any time.

Pb-free solder processes

For Pb-free solder processes, the product is qualified for MSL 3 according to IPC/JEDEC standard J-STD-020C.

During reflow $T_{PRODUCT}$ must not exceed 260 °C at any time.

Dry Pack Information

Surface mounted versions of the products are delivered in standard moisture barrier bags according to IPC/JEDEC standard J-STD-033 (Handling, packing, shipping and use of moisture/reflow sensitivity surface mount devices).

Using products in high temperature Pb-free soldering processes requires dry pack storage and handling. In case the products have been stored in an uncontrolled environment and no longer can be considered dry, the modules must be baked according to J-STD-033.

General reflow process specifications		SnPb eutectic	Pb-free
Average ramp-up ($T_{PRODUCT}$)		3°C/s max	3°C/s max
Typical solder melting (liquidus) temperature	T_L	183°C	221°C
Minimum reflow time above T_L		30 s	30 s
Minimum pin temperature	T_{PIN}	210°C	235°C
Peak product temperature	$T_{PRODUCT}$	225°C	260°C
Average ramp-down ($T_{PRODUCT}$)		6°C/s max	6°C/s max
Maximum time 25°C to peak		6 minutes	8 minutes

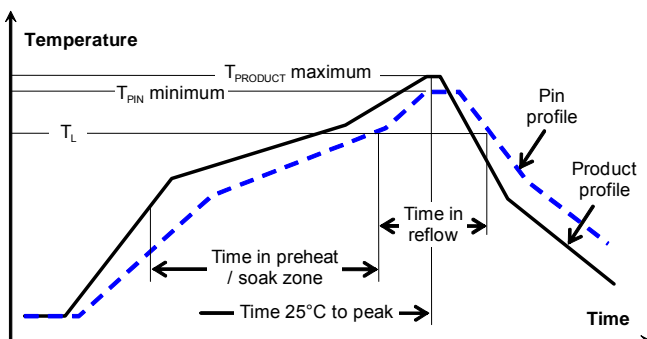

Thermocoupler Attachment

Pin 2A for measurement of minimum Pin (solder joint) temperature T_{PIN}

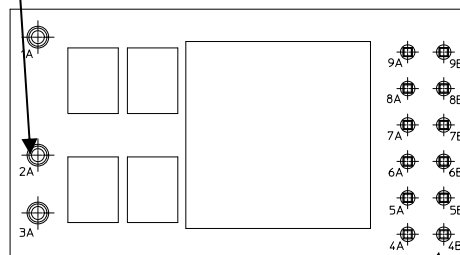

Pin 4B for measurement of maximum Product temperature $T_{PRODUCT}$

BMR 463 series POL Regulators
 Input 4.5-14 V, Output up to 20 A / 66 W

EN/LZT 146 434 R1A January 2011

© Ericsson AB

Soldering Information - Hole Mounting

The hole mounted product is intended for plated through hole mounting by wave or manual soldering. The pin temperature is specified to maximum to 270°C for maximum 10 seconds.

A maximum preheat rate of 4°C/s and maximum preheat temperature of 150°C is suggested. When soldering by hand, care should be taken to avoid direct contact between the hot soldering iron tip and the pins for more than a few seconds in order to prevent overheating.

A no-clean flux is recommended to avoid entrapment of cleaning fluids in cavities inside the product or between the product and the host board. The cleaning residues may affect long time reliability and isolation voltage.

Delivery Package Information

The products are delivered in antistatic carrier tape (EIA 481 standard).

Carrier Tape Specifications	
Material	PS, antistatic
Surface resistance	< 10 ⁷ Ohm/square
Bakeability	The tape is not bakable
Tape width, W	44 mm [1.73 inch]
Pocket pitch, P₁	24 mm [0.95 inch]
Pocket depth, K₀	12.4 mm [0.488 inch]
Reel diameter	381 mm [15 inch]
Reel capacity	200 products /reel
Reel weight	TBD kg/full reel

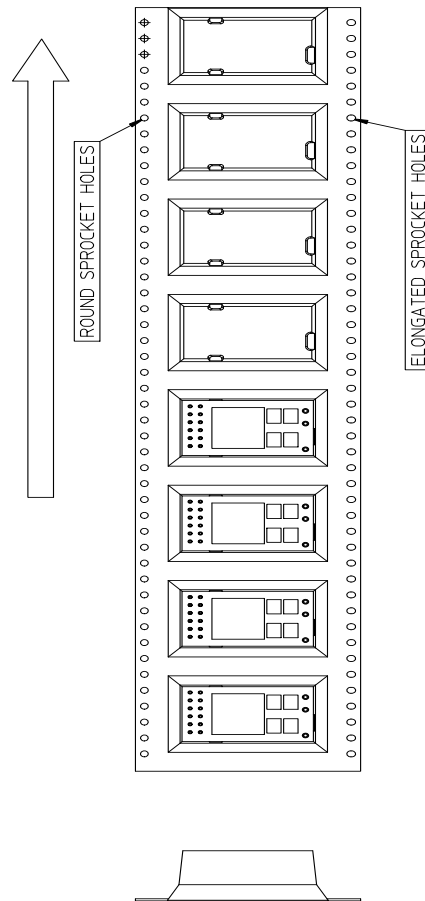

Technical Specification

BMR 463 series POL Regulators Input 4.5-14 V, Output up to 20 A / 66 W	EN/LZT 146 434 R1A January 2011
	© Ericsson AB

Product Qualification Specification

Characteristics			
External visual inspection	IPC-A-610		
Change of temperature (Temperature cycling)	IEC 60068-2-14 Na	Temperature range Number of cycles Dwell/transfer time	-40 to 100°C 1000 15 min/0-1 min
Cold (in operation)	IEC 60068-2-1 Ad	Temperature T _A Duration	-45°C 72 h
Damp heat	IEC 60068-2-67 Cy	Temperature Humidity Duration	85°C 85 % RH 1000 hours
Dry heat	IEC 60068-2-2 Bd	Temperature Duration	125°C 1000 h
Electrostatic discharge susceptibility	IEC 61340-3-1, JESD 22-A114 IEC 61340-3-2, JESD 22-A115	Human body model (HBM) Machine Model (MM)	Class 2, 2000 V Class 3, 200 V
Immersion in cleaning solvents	IEC 60068-2-45 XA, method 2	Water Glycol ether Isopropyl alcohol	55°C 35°C 35°C
Mechanical shock	IEC 60068-2-27 Ea	Peak acceleration Duration	100 g 6 ms
Moisture reflow sensitivity ¹	J-STD-020C	Level 1 (SnPb-eutectic) Level 3 (Pb Free)	225°C 260°C
Operational life test	MIL-STD-202G, method 108A	Duration	1000 h
Resistance to soldering heat ²	IEC 60068-2-20 Tb, method 1A	Solder temperature Duration	270°C 10-13 s
Robustness of terminations	IEC 60068-2-21 Test Ua1 IEC 60068-2-21 Test Ue1	Through hole mount products Surface mount products	All leads All leads
Solderability	IEC 60068-2-58 test Td ¹	Preconditioning Temperature, SnPb Eutectic Temperature, Pb-free	150°C dry bake 16 h 215°C 235°C
	IEC 60068-2-20 test Ta ²	Preconditioning Temperature, SnPb Eutectic Temperature, Pb-free	Steam ageing 235°C 260°C
Vibration, broad band random	IEC 60068-2-64 Fh, method 1	Frequency Spectral density Duration	10 to 500 Hz 0.07 g ² /Hz 10 min in each 3 perpendicular directions

Notes

¹ Only for products intended for reflow soldering (surface mount products)

² Only for products intended for wave soldering (plated through hole products)

Mouser Electronics

Authorized Distributor

Click to View Pricing, Inventory, Delivery & Lifecycle Information:

[Ericsson Power Modules:](#)

[BMR4630002/001](#) [BMR4631002/001](#)