



A1 PROs

Ai1002

Vertical Clock Driver for Camera System

GENERAL DESCRIPTION

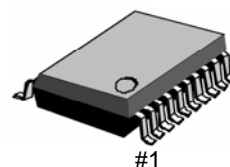
The **Ai1002** is a vertical driver for CCD image sensors. This IC is the successor of the Ai1001S with better features. 3.3V and 5V clock interface is acceptable while Ai1001S can accept only 5V clock interface.

20-pin SSOP

FEATURES

- Only two power supplies are (+15V and -8.5V) needed.
- 3.3V and 5V clock interface is acceptable.
- 20-pin SSOP package

APPLICATIONS

CCD Cameras

PROCESS

High Voltage CMOS

BLOCK DIAGRAM

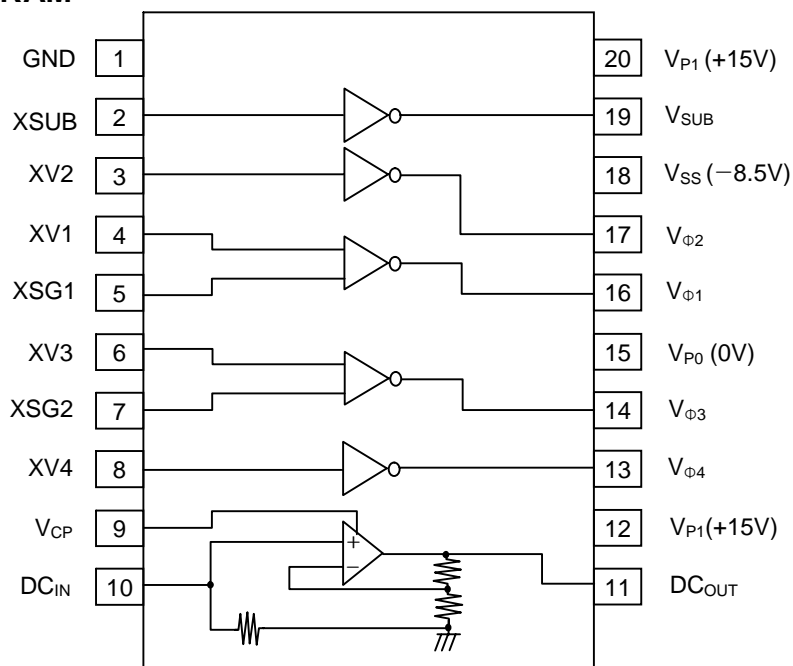

PIN DESCRIPTION

Pin	Symbol	I/O	Description
1	GND	-	Ground Control
2	XSUB	I	Output Control (V_{SUB})
3	XV2	I	Output Control ($V_{\Phi 2}$)
4	XV1	I	Output Control ($V_{\Phi 1}$)
5	XSG1	I	Output Control ($V_{\Phi 1}$)
6	XV3	I	Output Control ($V_{\Phi 3}$)
7	XSG2	I	Output Control ($V_{\Phi 3}$)
8	XV4	I	Output Control ($V_{\Phi 4}$)
9	V_{CP}	I	Power of Amp
10	DC_{IN}	I	OP-Amp Input (internal pull-down resistor)
11	DC_{OUT}	O	OP-Amp Output
12	V_{P1}	-	Power (15V)
13	$V_{\Phi 4}$	O	High Voltage Output (2 level : V_{P0} , V_{SS})
14	$V_{\Phi 3}$	O	High Voltage Output (3 level : V_{P0} , V_{SS} , V_{P1})
15	V_{P0}	-	Power (0V)
16	$V_{\Phi 1}$	O	High Voltage Output (3 level : V_{P0} , V_{SS} , V_{P1})
17	$V_{\Phi 2}$	O	High Voltage Output (2 level : V_{P0} , V_{SS})
18	V_{SS}	-	Power (- 8.5V)
19	V_{SUB}	O	High Voltage Output (2 level : V_{SS} , V_{P1})
20	V_{P1}	-	Power (15V)

ABSOLUTE MAXIMUM RATINGS ($T_a = 25^{\circ}\text{C}$)

Characteristics	Symbol	Value	Unit
Supply Voltage	V_{SS}	$0 \sim -10$	V
	V_{P1}	$-0.3 \sim V_{SS} + 35$	
	V_{P0}	$V_{SS} - 0.3 \sim 3.0$	
Input Voltage	V_I	$-0.3 \sim V_{P1} + 0.3$	
	V_{CP}	$-0.3 \sim V_{SS} + 35$	
Output Voltage	$V_{\phi1}, V_{\phi2}, V_{\phi3}, V_{\phi4}, V_{SUB}$	$V_{SS} - 0.3 \sim V_{P1} + 0.3$	
OP-Amp Output Current	I_{OUT}	± 5	mA
Operating Temperature	T_{OPR}	$-25 \sim +85$	$^{\circ}\text{C}$
Storage Temperature	T_{STG}	$-45 \sim +120$	

LOGIC FUNCTION TABLE

INPUT				OUTPUT		
XV1,3	XSG1,2	XV2,4	XSUB	$V_{\phi1,3}$	$V_{\phi2,4}$	V_{SUB}
L	L	X	X	V_{P1}	X	X
H	L	X	X	Z	X	X
L	H	X	X	V_{P0}	X	X
H	H	X	X	V_{SS}	X	X
X	X	L	X	X	V_{P0}	X
X	X	H	X	X	V_{SS}	X
X	X	X	L	X	X	V_{P1}
X	X	X	H	X	X	V_{SS}

X : Don't care
Z : High impedance

AC CHARACTERISTICS

($V_{P1} = 15V$, $V_{P0} = GND$, $V_{SS} = -8.5V$; $T_a = 25^{\circ}C$)

Description	Symbol	Test Condition	Min	Typ	Max	Unit
Delay Time	T_{PLM}	No Load (*1)	10	40	70	ns
	T_{PMH}	No Load(*1)	10	30	70	
	T_{PLH}	No Load(*1)	10	40	100	
	T_{PML}	No Load(*1)	10	100	200	
	T_{PHM}	No Load(*1)	10	100	180	
	T_{PHL}	No Load(*1)	10	60	100	
Rising Time	T_{TLM}	$V_{SS} \rightarrow V_{P0}$ (*1)	400	700	930	
	T_{TMH}	$V_{P0} \rightarrow V_{P1}$ (*1)	400	650	930	
	T_{TLH}	$V_{SS} \rightarrow V_{P1}$ (*1)	10	50	100	
	T_{TML}	$V_{P0} \rightarrow V_{SS}$ (*1)	200	300	500	
	T_{THM}	$V_{P1} \rightarrow V_{P0}$ (*1)	400	600	820	
	T_{THL}	$V_{P1} \rightarrow V_{P0}$ (*1)	10	50	100	
Output Noise Voltage	V_{CLH} , V_{CLL} V_{CMH} , V_{CML}	(*2)	-	-	0.5	V

(*1) Refer the timing diagram of page 5.

(*2) Refer the noise diagram of page 5.

DC CHARACTERISTICS

($V_{P1} = 15V$, $V_{P0} = GND$, $V_{SS} = -8.5V$, $V_{CP} = 22V$; $T_a = 25^{\circ}C$)

Description	Symbol	Test Condition	Min	Typ	Max	Unit
Supply Voltage	V_{P1}		14.5	15	15.5	V
	V_{SS}		- 9.5	- 8.5	- 7.5	
Input Voltage	V_{CP}	When V_{CP} is used	V_{P1}	22	23.5	
High Level Input Voltage	V_{IH}	(*3)	2.3	-	-	
Low Level Input Voltage	V_{IL}	(*3)	-	-	1.2	
Input Current	I_i	$V_{IN} = 0 \sim 5V$ (*3)	- 1.0	0.0	1.0	μA
	I_{DCIN}	$V_{DCIN} = 1.0V$	80	100	140	
Operation Current	I_{P1}	(*1)	-	2.0	3.5	mA
	I_{P0}	(*1)	-	4.5	5.0	
	I_{SS}	(*1)	- 8.5	- 6.5	-	
Output Current	I_{OL}	$V_{\Phi 1-4} = - 8.0V$	25	37	-	
	I_{OM1}	$V_{\Phi 1-4} = - 0.5V$	-	- 15	- 10	
	I_{OM2}	$V_{\Phi 1,3} = 0.5V$	9	13.5	-	
	I_{OH}	$V_{\Phi 1,3} = 14.5V$	-	- 18	- 12	
	I_{OSL}	$V_{SUB} = - 8.0V$	12	18	-	
	I_{OSH}	$V_{SUB} = 14.5V$	-	- 10.5	- 7	
Op-Amp Gain	G	$I_{OUT} = - 200\mu A$	X 4.0	X 4.2	X 4.7	
Gain Variation	ΔG	$T_a = - 20 \sim 75^{\circ}C$ (*2), $I_{OUT} = - 200mA$ $V_{DCIN} = 1.0 \sim 4.5V$	- 3	-	+ 3	%
Operation Current	I_{VCP}	$V_{DCIN} = 1.0 \sim 4.5V$ $I_{OUT} = 0mA$	0.08	-	1.0	mA

(*1) : Refer the test circuit of page 7. Shutter speed : 1/100000 sec.

(*2) : Refer the characteristics of OP-AMP of page 7.

(*3) : XV1 ~ 4, XSG1, XSG2, XSUB pin

TEST CIRCUIT

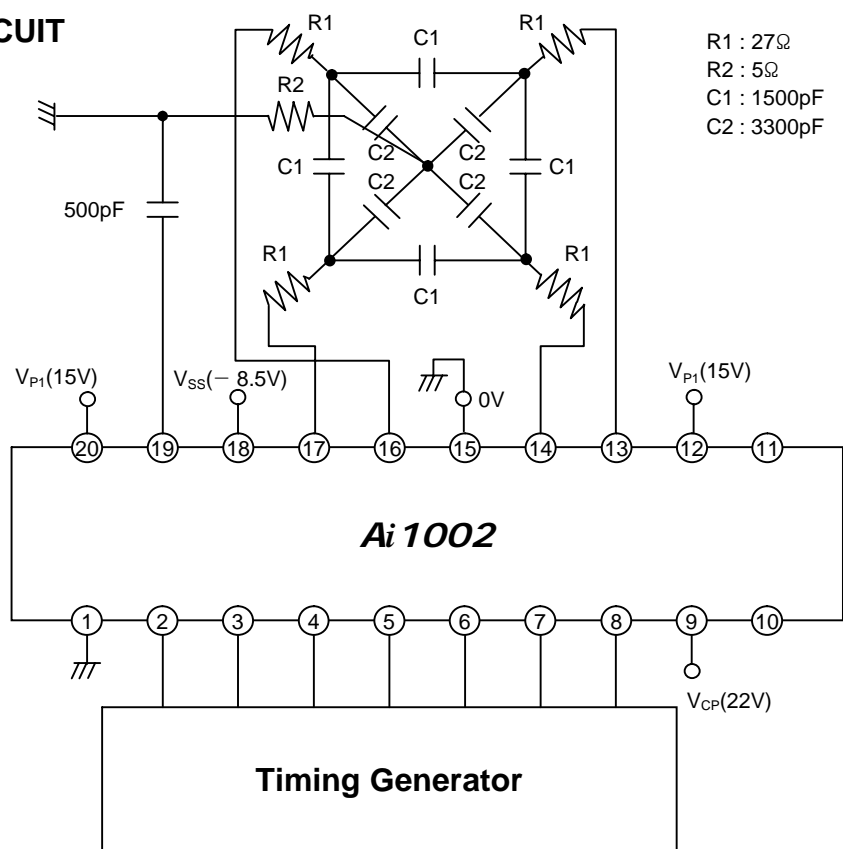

OP-AMP GAIN CHARACTERISTICS ($T_a = -20 \sim 75^\circ C$)

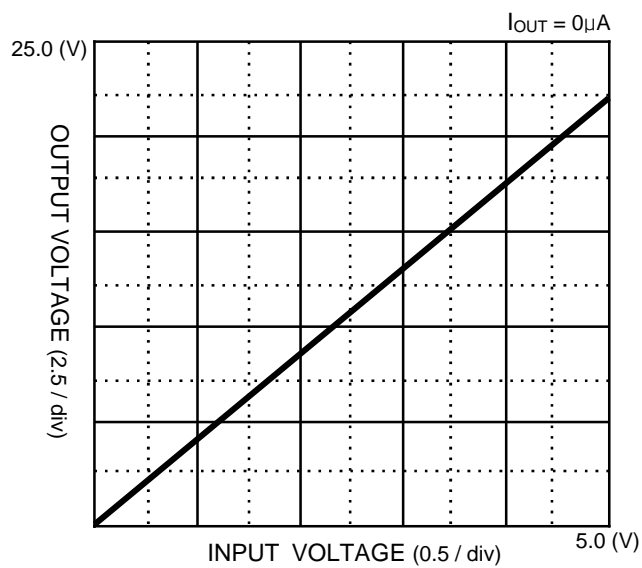

APPLICATION CIRCUIT

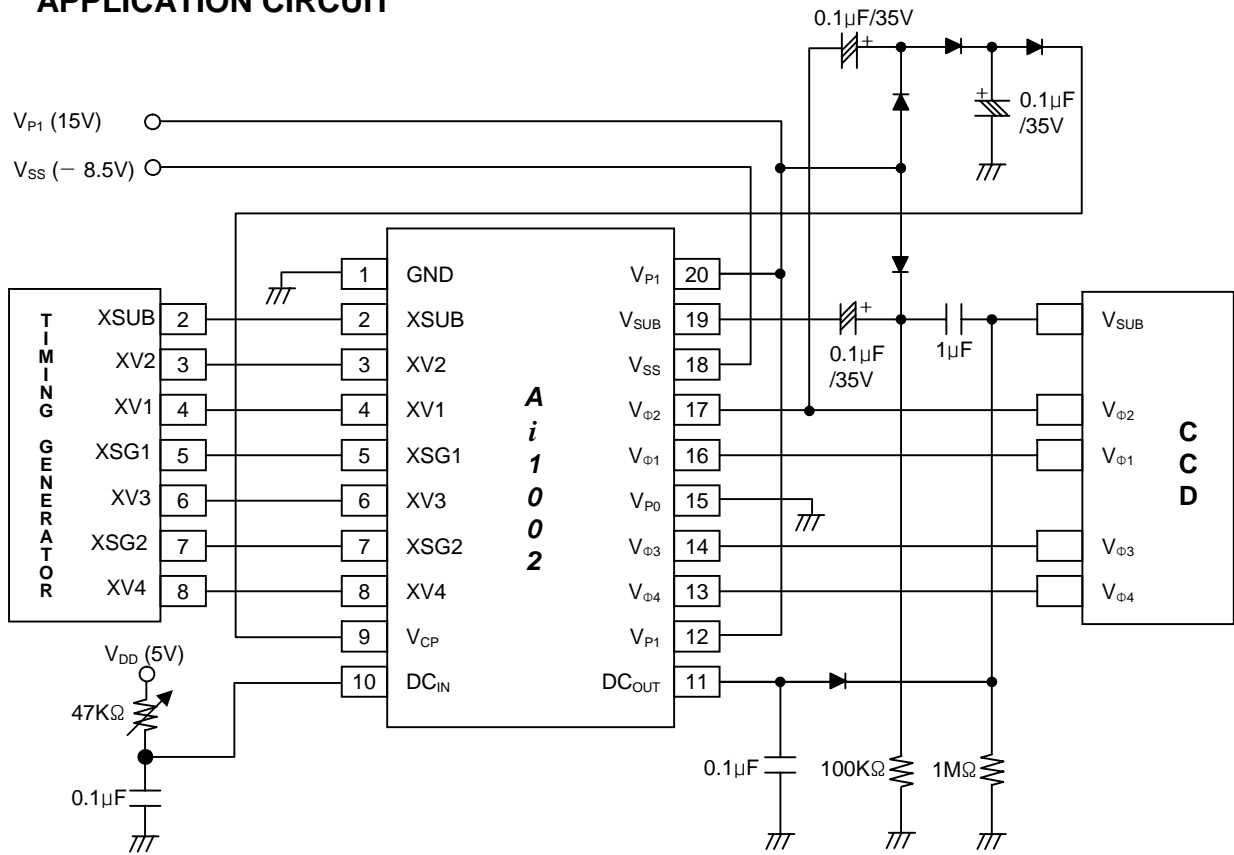

* In case of $DC_{OUT} \leq V_{P1} - 1.0V$, V_{CP} PIN connects with V_{P1} .

* **Warning** : When voltage is biased, You must keep this flow. If you don't keep this flow, Negative voltage is applied to CCD image sensor's SUB.

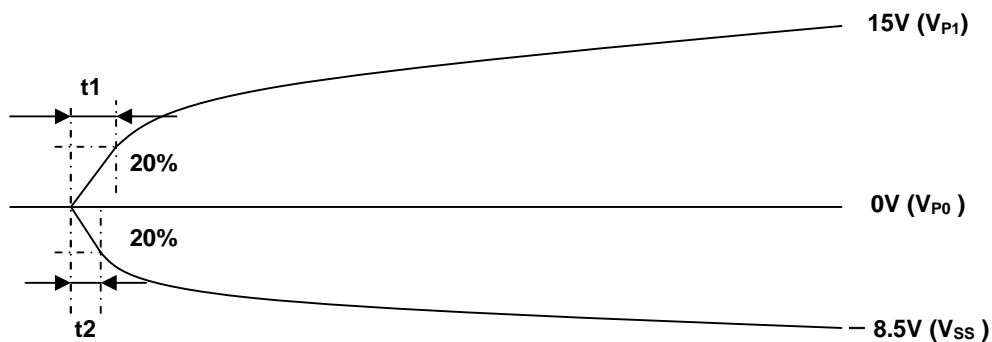

* $t1 \geq t2 \geq 10ms$

PACKAGE DIMENSION

20-pin SSOP

Unit : mm

