

Programmable Single Phase Energy Metering IC with Tamper Detection

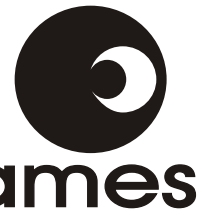

SA2007P

FEATURES

- Provides direct interface to mechanical counters
- Calibration and setup stored on external EEPROM - no trim pots required
- Monitors both Live and Neutral for tamper detection
- Flexible programmable features
- Meets the IEC 521/1036 Specification for Class 1 AC Watt hour meters
- Total power consumption rating below 50mW
- Adaptable to different types of sensors
- Operates over a wide temperature range
- Precision voltage reference on-chip
- Precision oscillator on chip

DESCRIPTION

The SAMES SA2007P is a single phase bi-directional energy metering integrated circuit. It provides a cost effective solution for energy meters with electro-mechanical displays, such as stepper motors and impulse counters. A precision oscillator, that replaces an external crystal is integrated on chip.

Two current sensor inputs allow the measurement of energy consumption on both the live and neutral lines.

Direction detection of energy flow as well as other common tamper conditions are flagged.

The power consumption on both the live and neutral are

continuously measured and the larger of the two is selected for energy metering.

The SA2007P drives the calibration LED, the indicator LEDs and the electro-mechanical counter directly.

The SA2007P does not require any external trim-pots. All required calibration and configuration data is read from a small external EEPROM.

The SA2007P integrated circuit is available in 20 pin dual-in-line plastic (DIP-20) and small outline (SOIC-20) package types.

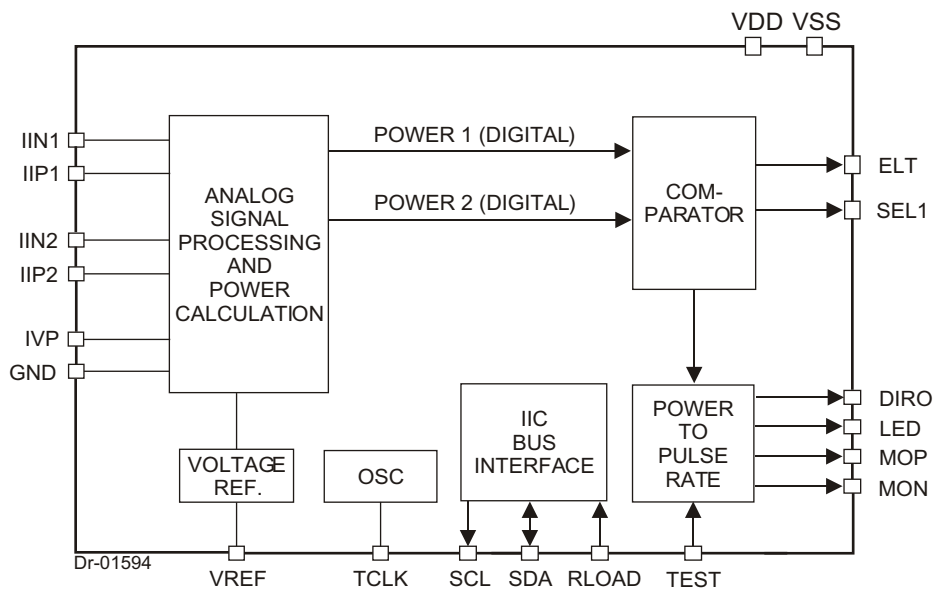

Figure 1: Block diagram

**ELECTRICAL CHARACTERISTICS**(V_{DD} = 2.5V, V_{SS} = -2.5V, over the temperature range -10°C to +70°C[#], unless otherwise specified.)

Parameter	Symbol	Min	Typ	Max	Unit	Condition
Operating temp. Range	T _O	-25		+85	°C	
Supply Voltage: Positive	V _{DD}	2.25		2.75	V	
Supply Voltage: Negative	V _{SS}	-2.75		-2.25	V	
Supply Current: Positive	I _{DD}	4.7	6.6	9.4	mA	
Supply Current: Negative	I _{SS}	4.7	6.6	9.4	mA	
Current Sensor Inputs (Differential)						
Input Current Range	I _{II}	-25		+25	µA	Peak value
Voltage Sensor Input (Asymmetrical)						
Input Current Range	I _{IV}	-25		+25	µA	Peak value
Pin VREF Ref. Current Ref. Voltage	-I _R V _R	45 1.1	50 1.2	55 1.3	µA V	With R = 24k connected to V _{SS} Reference to V _{SS}
Digital I/O						
Pins RLOAD, TCLK, TEST, SEL1, ELT, SDA Input High Voltage Input Low Voltage	V _{IH} V _{IL}	V _{DD} -1		V _{SS} +1	V V	
Pins MOP, MON, LED, SCL, DIRO Output High Voltage Output Low Voltage	V _{OH} V _{OL}	V _{DD} -1		V _{SS} +1	V V	I _{OH} = -2mA I _{OL} = 5mA
Pin SDA Pull up current	-I _{IL}	24		54	µA	V _I = V _{SS}
Pins TEST, RLOAD, TCLK Pull down current	I _{IH}	48		110	µA	V _I = V _{DD}

Extended Operating Temperature Range available on request.

ABSOLUTE MAXIMUM RATINGS*

Parameter	Symbol	Min	Max	Unit
Supply Voltage	V _{DD} - V _{SS}	-0.3	6.0	V
Current on any pin	I _{PIN}	-150	+150	mA
Storage Temperature	T _{STG}	-40	+125	°C
Operating Temperature	T _O	-40	+85	°C

*Stresses above those listed under "Absolute Maximum Ratings" may cause permanent damage to the device. This is a stress rating only. Functional operation of the device at these or any other condition above those indicated in the operational sections of this specification, is not implied. Exposure to Absolute Maximum Ratings for extended periods may affect device reliability.

**PIN DESCRIPTION**

PIN	Designation	Description
20	GND	Analog Ground. The voltage to this pin should be mid-way between V_{DD} and V_{SS} .
8	V_{DD}	Positive supply voltage. The voltage to this pin is typically +2.5V if a shunt resistor is used for current sensing or in the case of a current transformer a +5V supply can be applied.
14	V_{SS}	Negative supply voltage. The voltage to this pin is typically -2.5V if a shunt resistor is used for current sensing or in the case of a current transformer a 0V supply can be applied.
19	IVP	The current into the A/D converter should be set at $14\mu A_{RMS}$ at nominal mains voltage. The voltage sense input saturates at an input current of $\pm 25\mu A$ peak.
1, 2, 3, 4	IIN1, IIP1 IIN2, IIP2	Inputs for current sensor - channel 1 and channel 2. The shunt resistor voltage from each channel is converted to a current of $16\mu A_{RMS}$ at rated conditions. The current sense input saturates at an input current of $\pm 25\mu A$ peak.
5	VREF	This pin provides the connection for the reference current setting resistor. A 24k resistor connected to V_{SS} sets the optimum operating condition.
6	SCL	Serial clock output. This output is used to strobe data from the external EEPROM.
7	SDA	Serial data. Send and receive data from an external EEPROM.
9, 12	MON, MOP	Motor pulse outputs. These outputs can be used to drive an impulse counter or stepper motor directly.
13	LED	Calibration LED output. Refer to section Led Output (LED) for the pulse rate output options.
15	RLOAD	Configuration reload input. A falling edge will trigger a register reload from the external EEPROM.
16	SEL1	Current channel select output. This output indicates which channel is been used for kWh metering.
17	ELT	Earth loop tamper output. This output indicates an earth loop tamper condition.
18	DIRO	Direction output. This output indicates the energy flow direction
10, 11	TEST, TCLK	Test input. Connect to V_{SS} for normal operation.

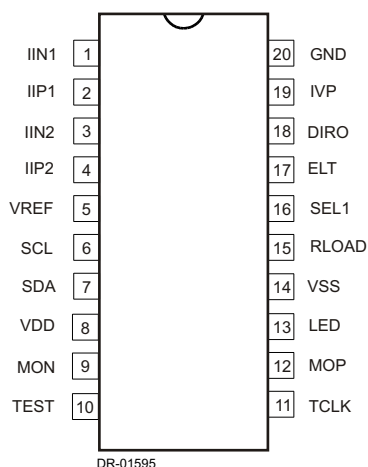
**ORDERING INFORMATION**

Part Number	Package
SA2007PPA	DIP-20
SA2007PSA	SOIC-20

Figure 2: Pin connections: Package: DIP-20, SOIC-20

FUNCTIONAL DESCRIPTION

The SA2007P is a CMOS mixed signal Analog/Digital integrated circuit, which performs power/energy calculations across a power range of 1000:1, to an overall accuracy of better than Class 1.

The integrated circuit includes all the required functions for single phase power and energy measurement such as oversampling A/D converters for the voltage and current sense inputs, power calculation and energy integration. Internal offsets are eliminated through the use of cancellation procedures. The SA2007P incorporates an anti-tamper scheme by continuously measuring the power consumption on both LIVE and NEUTRAL lines. A fault is indicated when these measurements differ by more than 12.5%. The SA2007P generates pulses with a frequency proportional to the larger of the two current measurements. The source (LIVE or NEUTRAL) for these pulses is indicated on the SEL1 pin. The metering of energy consumption is taken from the source, which shows the higher consumption.

Various pulse outputs (MOP, MON and LED) are available. The pulse rate on these pins follows the active power consumption measured.

A low voltage stepper may be driven directly from the device by connecting it between the MOP and MON pins, alternatively an impulse counter may be driven directly by connecting it between MOP and V_{SS} .

The SA2007P configures itself from an external low cost EEPROM that contain all meter configurations and calibration data. No external trimming is required for this device. Calibration of the meter may be fully automated.

POWER CALCULATION

In Figure 7, the voltage drops across the current transformers terminating resistors are converted to currents for each current sense input, by means of resistors R_{10} and R_{11} (channel 1) as well as R_{12} and R_{13} . (channel 2). The current sense input saturates at an input current of $\pm 25\mu\text{A}$ peak.

The mains voltage (230VAC) is divided down through a divider to $14V_{RMS}$. The current into the A/D converter input is set at $14\mu\text{A}_{RMS}$ at nominal mains voltage, via resistor R_7 (1M).

See Device Configuration for more details on the processing of measured energy to frequency outputs.

ANALOG INPUT CONFIGURATION

The input circuitry of the current and voltage sensor inputs are illustrated in figure 3. These inputs are protected against electrostatic discharge through clamping diodes.

The feedback loops from the outputs of the amplifiers A_I and A_V generate virtual shorts on the signal inputs. Exact duplications of the input currents are generated for the analog signal processing circuitry.

AUTOMATIC DEVICE CONFIGURATION (BOOT UP)

During power up, registers containing configuration and calibration information are updated from an external EEPROM. The device itself never writes to the EEPROM so any write protect features offered by manufacturer of EEPROM's may be used to protect the configuration and calibration data of the meter. The device reloads its configuration every 1193 seconds from the external EEPROM in order to ensure correct operation of the meter. Every data byte stored in the EEPROM is protected with a checksum byte to ensure data integrity.

ELECTROSTATIC DISCHARGE (ESD) PROTECTION

The SA2007P integrated circuit's input's/outputs are protected against ESD.

POWER CONSUMPTION

The power consumption rating of the SA2007P integrated circuit is less than 30mW.

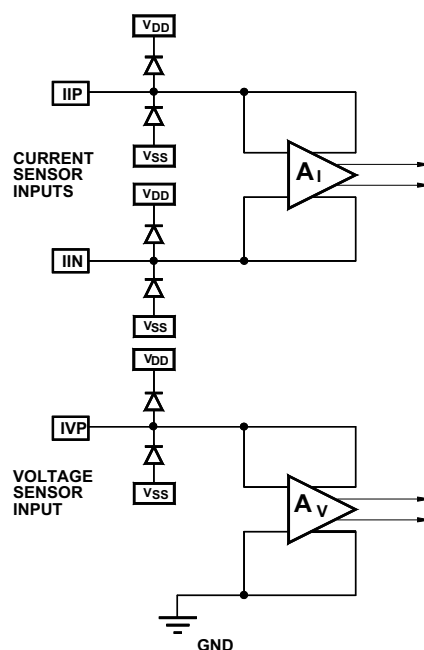

DR-01288

Figure 3: Analog input internal configuration



INPUT SIGNALS

VREF

A bias resistor of 24k set optimum bias and reference conditions on chip. Calibration of the SA2007P should be done as described in the Device Configuration section.

Serial Data (SDA)

The SDA pin connects directly to the SDA pin of an external EEPROM. The pin is used to transfer data between the EEPROM to the SA2007P. An external pull up resistor is not needed.

Serial Clock (SCL)

The SCL pin connects directly to the SCL pin of an external EEPROM. The SCL output is used to strobe data at a rate of 50kHz out of the EEPROM. An external pull up resistor is not needed.

Configuration Reload (RLOAD)

A falling edge on the RLOAD pin, will trigger a register update from the external EEPROM. This feature may be used during calibration to load updated register data in the SA2007P. For normal operation of the SA2007P the RLOAD pin may be left floating.

OUTPUT SIGNALS

Motor output (MOP, MON)

The motor pulse width is programmable for 71ms and 142ms. The MON pulse will follow the MOP pulse within the selected pulse width time. This prevents that the motor armature is in the wrong position after a power failure. Both MOP and MON outputs are active high. One energy pulse is represented by a MOP pulse followed by a MON pulse. The motor drive wave forms are shown in figure 4.

LED output (LED)

Three options for the LED output pulse rate are available, 6400 and 3200 pulses per kWh, as well as a pulse rate of 1252 pulses per second at rated conditions. At 1252 pulse per second t_{LED} is 71 μ s, for the other options t_{LED} is 10ms. The LED output is active low as in figure 5.

An integrated anti-creep function prevents any output pulses if the measured power is less than 0.02% of the meters rated current.

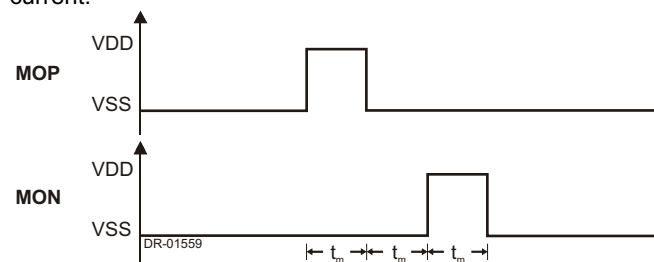

Figure 4: Motor drive on MON and MOP pins

Selected Input Indicator (SEL1)

The SA2007P continuously compares the power consumptions on current channel 1 inputs and current channel 2 inputs. The larger of the two measurements is used for metering. The SEL1 output pin indicates which channel is currently being used for the pulse output.

Signal Output	Value	Description
SEL 1	0	Channel 1 selected (IIN1/IIP1)
	1	Channel 2 selected (IIN2/IIP2)

Switching between channels will not be faster than once per second in case both channels are balanced.

Earth Loop Tamper Indication (ELT)

In case the power measurements from both current channels differ by more than 12.5%, (indicating a earth loop tamper condition), the ELT output is set to zero. The SA2007P continues to generate output pulses from the larger of the two measured powers in this condition. The ELT output is active low.

Direction Indication (DIRO)

The SA2007P provides information about the energy flow direction of both current channels on pin DIRO .

A logic 1 on pin DIRO indicates reverse energy flow of both current channels. Reverse energy flow is defined as the condition where the voltage sense input and current sense input are out of phase (greater than 90 degrees). Positive energy flow, when voltage sense and both current sense input are in phase, is indicated on pin DIRO as a logic 0.

The DIRO output will toggle between 1 and 0 a rate of 1Hz in case one of the current channels measure positive energy and the other negative energy. The condition may accure with a improper installed or tampered meter.

The DIRO pin may be used to drive a LED in order to indicate reverse energy.

Signal Output	Value	Description
DIRO	1	Reverse energy flow
	0	Forward energy flow
	1Hz	Out of phase current channels

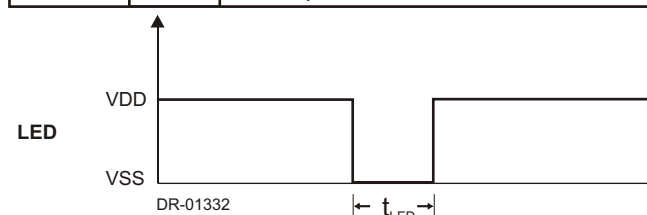

Figure 5: LED pulse output



DEVICE CONFIGURATION SIGNAL FLOW DESCRIPTION

The following is an overview of the SA2007P's registers. For a detailed description of each parameter please refer to parameter description section.

Figure 6 shows the various registers in the SA2007P's power to pulse rate block. The inputs to this block are two single bit pulse density modulated signals, each having a pulse rate of 641454 pulses per second at rated conditions. The parameters Kc1, Kc2, Ne, Cs, Kr, Cres, and Cled contain values which are read from the external EEPROM during power up.

The divider registers, *Channel 1 Balance* and *Channel 2*

Balance, are used for calibration and to balance the gain of each channel. The *Earth Leakage Compensation* register is used to compensate for any permissible earth leakage that may cause the SA2007P to indicate a tamper condition at low current. The *Channel Select* register selects the source (channel 1 or channel 2) which will be used for the pulse output. Register *Rated Condition* is used to program the rated condition of the meter and feeds the registers *LED-constant* and *Counter Resolution* with the applicable pulse rate. These two registers are programmed to select the LED output rate and the counter resolution (pulses per kWh) respectively. The *Counter Pulse Width* register is used to program the pulse width for the mechanical counter driver output MOP and MON.

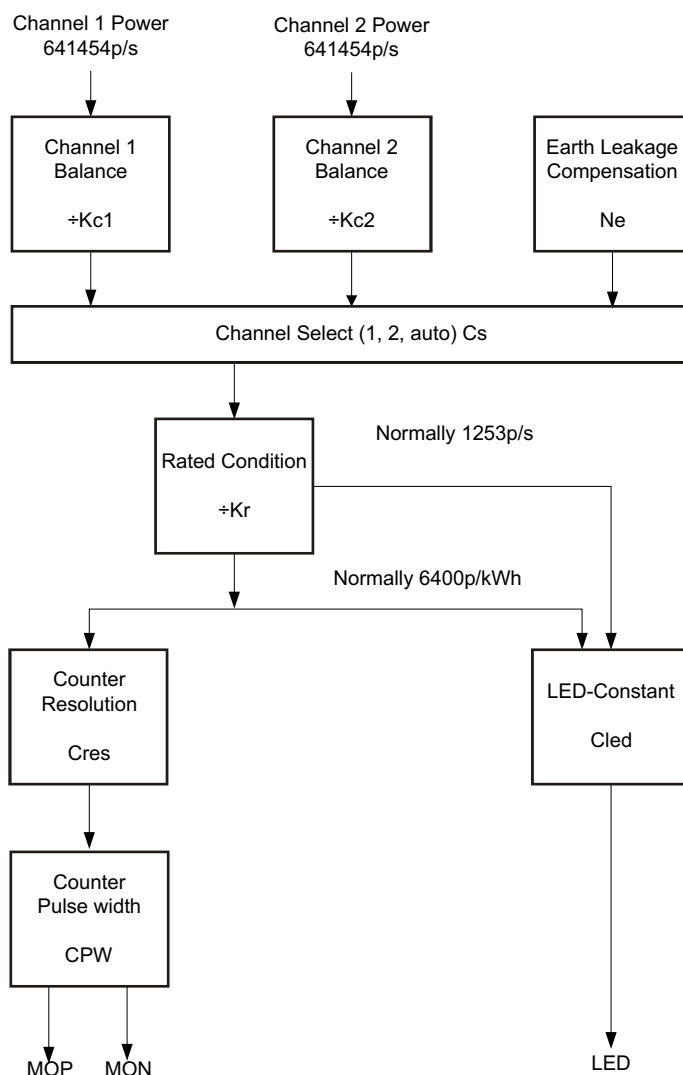

Figure 6: Signal flow block diagram



PARAMETER DESCRIPTION

Refer to the EEPROM memory allocation map as well as the Signal flow diagram figure 6, for a description of the registers used in this section.

EEPROM Memory Allocation

The following table shows the EEPROM memory allocation as well as the corresponding name. The uneven byte always contains the XORed byte of the previous even byte. This is the checksum byte used by the SA2007P to ensure data integrity.

Channel Balance (Kc)

Kc defines the dividing factor, which is applied to the incoming pulse rate. This value is typically 511. This factor is used for calibration and gain balancing of the 2 current channels. The value for Kc is usually between 400 and 640.

Kc is made up of 2 bytes, D12 and D14 or D16 or D18 which forms a 10 bit value.

Rated Condition (Kr)

Kr is used to program the rated condition of the meter. This feature is required for a correct counter increment of meters designed for different rated conditions using the same integrated circuit. Rated conditions from less than 10A to several 100A are possible.

The channel balance values should be used to compensate for rounding errors in Kr. Kr is calculated as follows:

$$Kr = (1252 \times 1000 \times 3600) / (\text{Rated volt} \times \text{Rated current} \times 6400) - 1$$

Kr is made up of 1 byte (D20)

Description	E ² Address	Contents	Bit [7:0]	Name
Channel 1 Balance LSB	12	Kc1	vvvvvvvv	D12
	13	XOR of ADDR 12	xxxxxxxx	
Channel 1 Balance MSB	14	Kc1	-----vv	D14
	15	XOR of ADDR 14	xxxxxxxx	
Channel 2 Balance LSB	16	Kc2	vvvvvvvv	D16
	17	XOR of ADDR 16	xxxxxxxx	
Channel 2 Balance MSB	18	Kc2	-----vv	D18
	19	XOR of ADDR 18	xxxxxxxx	
Rated Condition	20	Kr	vvvvvvvv	D20
	21	XOR of ADDR 22	xxxxxxxx	
Led Pulse-rate	22	Cled	-----vv	D22
	23	XOR of ADDR 22	xxxxxxxx	
Counter Pulse-width	24	Cpw	0v-----	D24
Counter Resolution	24	Cres	-----vv	
	25	XOR of ADDR 24	1xxxxxxxx	
Earth leak Compensation	26	Ne	-----vv	D26
Channel Select Mode	26	Cs	----v--	
	27	XOR of ADDR 24	xxxxxxxx	

KEY: (- = DON'T CARE); (V = VALUE/PARAMETER); (0,1 = LOGICAL VALUE); (X = BIT-XOR)

**LED Pulse-rate (CLED)**

Two bits of byte D22 allow for the selection of 3 different LED Pulse-rate as follows.

D22[1]	D22[0]	Calibrated LED - Output
0	0	6400 p/KWh
0	1	3200 p/KWh
1	-	1252 pulses/second @rated for fast calibration

Refer to LED output section for details on the LED pulse width.

Counter Pulse-Width (CPW)

The pulse width for the mechanical counter driver output is selectable to accommodate various step-motor and impulse-counter requirements. Bit 6 from byte D24 selects the pulse rate as follows:

D24[6]	Counter Pulse-Width
0	71ms
1	142ms

Counter Resolution (CRES)

Bit 1 and 0 from byte D24 allow for the selection of 3 different counter resolutions. Note that one energy pulse is represented by a MOP pulse followed by a MON pulse.

D24[1]	D24[0]	Counter Resolution
0	0	1 p/KWh
1	0	10 p/KWh
-	1	100 p/KWh

Channel Select Mode (CS)

For calibration purposes, the source for the energy metering may be selected from a specific channel. The ELT-indication is not influenced, but the metering is taken from the selected channel only. For normal operation, the channel select mode is set to automatic mode so that the larger of the two channels is used for energy measurement. Bits 3 and 2 of byte D26 sets the channel select mode as follows:

D26[3]	D26[2]	Metering Source
-	0	Automatic, channel 1 or 2 whichever shows higher consumption
1	1	Channel 1
0	1	Channel 2

Earth Leak Compensation (NE)

Earth leakage in domestic wiring systems could result in tamper detection at low current levels. The SA2007P caters for these conditions, by taking possible earth leakage into account when comparing the power consumption in live and neutral.

The value for the permissible earth leakage is usually around 30mA. It has to be adjusted according to the rated meter condition and allows for derivations from the 30mA value. The actual value of the leak current can be calculated from the following formula:

$$I_{leak} = \text{Rated current} \times N_e$$

I_{leak} is the earth leakage current in mA used for correction. this value is subtracted from the difference measured between live and neutral power.

N_e is made up of bits 1 and 2 of byte D26 and can be set as follows:

D26[1]	D26[0]	N_e factor
0	0	0.15
0	1	0.076
1	-	0.038

**TYPICAL APPLICATION**

The analog (metering) interface described in this section is designed for measuring 230V/60A with precision better than Class 1.

The most important external components for the SA2007P integrated circuit are the current sense resistors, the voltage sense resistors and the bias setting resistor. The resistors used in the metering section should be of the same type so temperature effects are minimized.

Current Input IIN1, IIP1, IIN2, IIP2

Two current transformers are used to measure the current in the live and neutral phases. The output of the current transformer is terminated with a low impedance resistor. The voltage drop across the termination resistor is converted to a current that is fed to the differential current inputs of the SA2007P.

CT Termination Resistor

The voltage drop across the CT termination resistor at rated current should be at least 20mV. The CTs have low phase shift and a ratio of 1:2500. The CT is terminated with a 3.6 resistor giving a voltage drop of 86.4mV across the termination resistor at rated conditions (I_{max} for the meter).

Current Sensor Input Resistors

The resistors R10, R11 and R12, R13 define the current level into the current sense inputs of the SA2007P. The resistor values are selected for an input current of 16μA on the current inputs of the SA2007P at rated conditions. For a 60A meter at 2500:1 CT the resistor values are calculated as follows:

$$\begin{aligned} R10 = R11 &= (I_L / 16\mu A) \times R_{SH} / 2 \\ &= 60A / 2500 / 16\mu A \times 3.6 / 2 \\ &= 2.7k \end{aligned}$$

I_L = Line current

R_{SH} = CT Termination resistor

2500 = CT ratio

The two current channels are identical so $R10 = R11 = R12 = R13$.

Voltage Input IVP

The voltage input of the SA2007P (IVP) is driven with a current of 14μA at nominal mains voltage. The voltage input saturates

at approximately 17μA. At a nominal voltage current of 14μA allows for 20% overdriving. The mains voltage is divided with a voltage divider to 14V that is fed to the voltage input pins via a 1M resistor.

Voltage Divider

The voltage divider is calculated for a voltage drop of 14V. Equations for the voltage divider in figure 4 are:

$$\begin{aligned} RA &= R1 + R2 + R3 \\ RB &= R7 \parallel R5 \end{aligned}$$

Combining the two equations gives:

$$(RA + RB) / 230V = RB / 14V$$

Values for resistors $R5 = 24k$ and $R7 = 1M$ is chosen.

Substituting the values result in:

$$\begin{aligned} RB &= 23.437k \\ RA &= RB \times (230V / 14V - 1) \\ RA &= 362k \end{aligned}$$

Standard resistor values for R1, R2 and R3 are chosen to be 120k each.

The capacitor C1 is used to compensate for phase shift between the voltage sense inputs and the current sense inputs of the device, in cases where CTs with phase errors are used. The phase shift caused by the CT may be corrected by inserting a capacitor in the voltage divider circuit. To compensate for a phase shift of 0.18 degrees the capacitor value is calculated as follows:

$$\begin{aligned} C &= 1 / (2 \times \text{Mains frequency} \times R5 \times \tan(\text{Phase shift angle})) \\ C &= 1 / (2 \times 50 \times 1M \times \tan(0.18 \text{ degrees})) \\ C &= 1.013\mu F \end{aligned}$$

Reference Voltage Bias resistor

R6 defines all on chip and reference currents. With $R6 = 24k$ optimum conditions are set. Device calibration is done with calibration data.

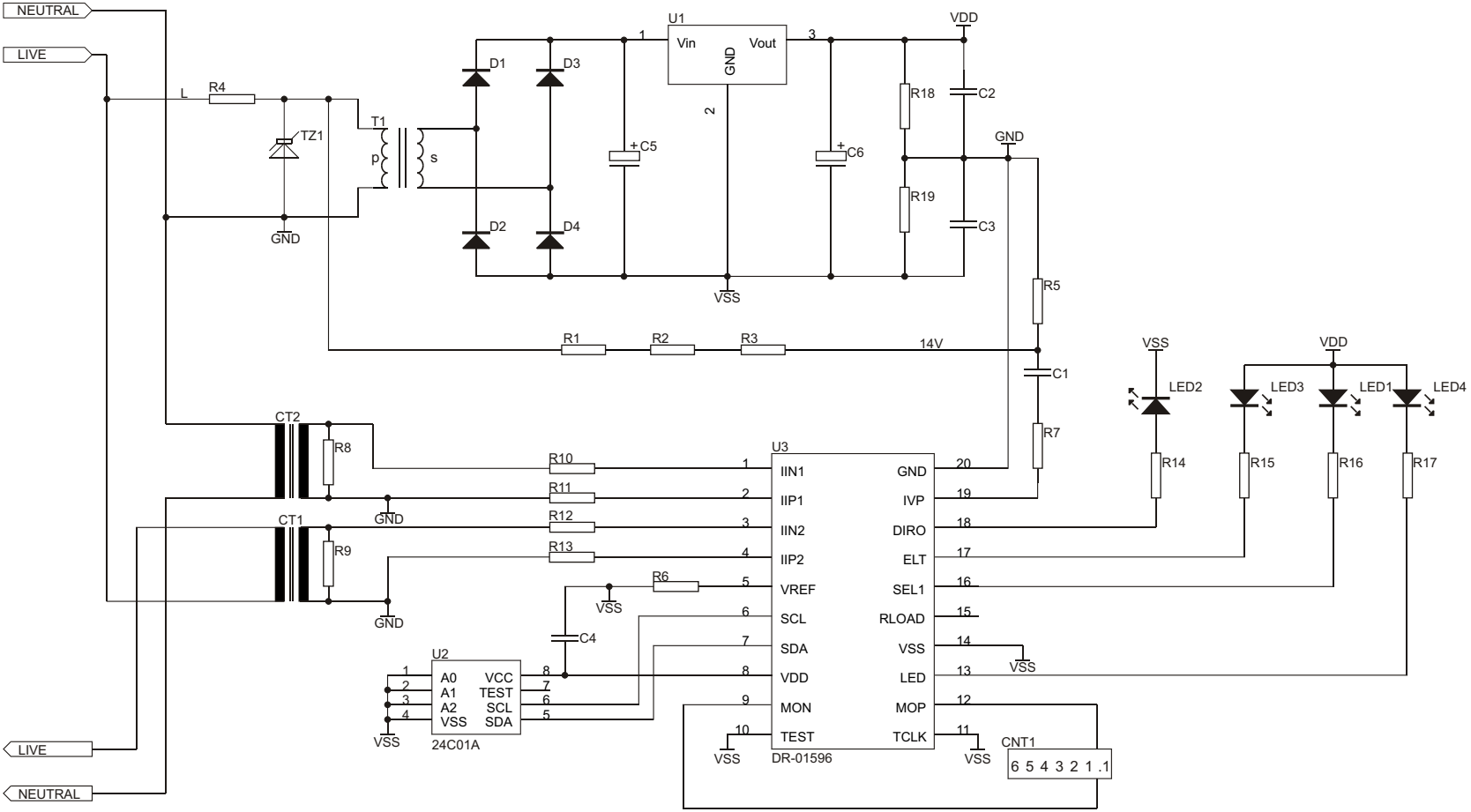

Figure 7: Typical application circuit



Parts List for Application Circuit: Figure 7

Item	Symbol	Description	Detail
1	U1	SA2007P	DIP-20/SOIC-20
2	U2	AT24C01, or equivalent device	
3	D1	Diode, Silicon 1N4148	or Similar
4	D2	Diode, Silicon 1N4148	or Similar
5	D3	Diode, Silicon 1N4148	or Similar
6	D4	Diode, Silicon 1N4148	or Similar
7	LED1	Light emitting diode, Green	
8	LED2	Light emitting diode, Amber	
9	LED3	Light emitting diode, Red	
10	LED4	Light emitting diode, Green	
11	R1	Resistor, 120k, 1/4W, 1%, metal	
12	R2	Resistor, 120k, 1/4W, 1%, metal	
13	R3	Resistor, 120k, 1/4W, 1%, metal	
14	R4	Resistor, 10 , 2W, Wire wound	
15	R5	Resistor, 24k, 1/4W, 1%, metal	
16	R6	Resistor, 24k, 1/4W, 1%, metal	
17	R7	Resistor, 1M, 1/4W, 1%, metal	
18	R8	Resistor, 1/4W, 1%, metal	Note 2
19	R9	Resistor, 1/4W, 1%, metal	Note 2
20	R10	Resistor, 1/4W, 1%, metal	Note 1
21	R11	Resistor, 1/4W, 1%, metal	Note 1
22	R12	Resistor, 1/4W, 1%, metal	Note 1
23	R13	Resistor, 1/4W, 1%, metal	Note 1
24	R14	Resistor, 1k, 1/4W	
25	R15	Resistor, 1k, 1/4W	
26	R16	Resistor, 1k, 1/4W	
27	R17	Resistor, 1k, 1/4W	
28	R18	Resistor, 1k, 1/4W, 1%, metal	
29	R19	Resistor, 1k, 1/4W, 1%, metal	
30	C1	Capacitor	Note 4
31	C2	Capacitor, 220nF	
32	C3	Capacitor, 220nF	
33	C4	Capacitor, 820nF	Note 3
34	C5	Capacitor, 2200μF, 25V, electrolytic	
35	C6	Capacitor, 100μF, 16V, electrolytic	
36	CT1	Current Transformer	
37	CT2	Current Transformer	
38	T1	Transformer, 230V/9V	
39	U1	78LC05, Voltage regulator	
40	CNT1	Bipolar step motor	
41	TZ1	400V, Metal oxide varistor	

Note 1: Resistor (R10, R11, R12 and R13) values are dependent upon the selected value of R8 and R9

Note 2: See TYPICAL APPLICATION when selected the value of R8 and R9.

Note 3: Capacitor (C4) to be positioned as closed to Supply Pins (V_{DD} & V_{SS}) of U-1, as possible.

Note 4: Capacitor (C1) selected to minimize phase error introduced by current transformer (typically 1.5μF for normal CTs)

**DISCLAIMER:**

The information contained in this document is confidential and proprietary to South African Micro-Electronic Systems (Pty) Ltd ("SAMES") and may not be copied or disclosed to a third party, in whole or in part, without the express written consent of SAMES. The information contained herein is current as of the date of publication; however, delivery of this document shall not under any circumstances create any implication that the information contained herein is correct as of any time subsequent to such date. SAMES does not undertake to inform any recipient of this document of any changes in the information contained herein, and SAMES expressly reserves the right to make changes in such information, without notification, even if such changes would render information contained herein inaccurate or incomplete. SAMES makes no representation or warranty that any circuit designed by reference to the information contained herein, will function without errors and as intended by the designer.

Any sales or technical questions may be posted to our e-mail address below:
energy@sames.co.za

For the latest updates on datasheets, please visit our web site:
<http://www.sames.co.za>

**SOUTH AFRICAN MICRO-ELECTRONIC SYSTEMS
DIVISION OF LABAT TECHNOLOGIES (PTY) LTD**

Tel: (012) 333-6021
Tel: Int +27 12 333-6021
Fax: (012) 333-8071
Fax: Int +27 12 333-8071

**P O BOX 15888
33 ELAND STREET
LYNN EAST 0039
REPUBLIC OF SOUTH AFRICA**

**33 ELAND STREET
KOEDOESPOORT INDUSTRIAL AREA
PRETORIA
REPUBLIC OF SOUTH AFRICA**