



INSTRUCTIONAL MANUAL ADVANCED WIRE TRACER



MODELS:
AT-2001 AT-2002 AT-2003 AT-2004 AT-2005

Version : 05/2007 / PAEB27439150



BEHA-AMPROBE GmbH
In den Engematten 14, D-79286 Glottertal, Germany
Phone: +49 (0)7684 - 8009-0, Fax: +49 (0)7968 - 8009-410
www.amprobe.com – info@amprobe.com

CONTENTS

INTRODUCTION 3

AT-2000 SERIES PRODUCT DESCRIPTION 4

COMPONENT DESCRIPTION..... 6

 R2000 Receiver..... 6

 Changing Batteries 6

 Using the R2000 Receiver 7

 S2300 and S2600 Load Signal Generators (LSG's) 8

 Using the S2300 and S2600 Load Signal Generators (LSG's) 10

 T2200 Transmitter 11

 Using the T2200 Transmitter..... 11

 A2201 Clamp-On Transmitter Accessory 12

 Using the A2201 Clamp-on transmitter Accessory 13

 B2024 Battery Pack..... 13

 B2025 220V Converter/Recharger..... 13

 EU-200 sensing lines with test prods and alligator clips..... 14

APPLICATION NOTES 14

 Finding Opens 14

 Finding Ground Faults..... 15

 Tracing Wires in Conduit..... 16

 Locating Circuit Breakers or Fuses..... 17

 Tracing Energized Wires..... 17

 Tracing Unenergized Lines and Finding Shorts..... 18

 Locating Individual Wires in a Bundle 19

 Locating Outlets from the Breaker Panel 20

 Locating Buried Conduit or Metal Pipe 21

SPECIFICATIONS 22

PRECAUTIONS FOR PERSONAL AND INSTRUMENT PROTECTION

IMPORTANT:

1. Before using any electrical instrument, it should be checked to make certain it is operating properly.
2. In many instances, you will be working with dangerous levels of voltages and/or current, therefore, it is important that you avoid direct contact with any uninsulated, current carrying surfaces. Appropriate insulated gloves, safety glasses and protective clothing should be worn.
3. Before attaching anything to the conductor, make sure the voltage present is not beyond the range of the instrument.
4. When not in use, keep the Instrument in its carrying case.
5. When the R2000 or the T2200 will not be used for a period of time, remove the battery.

INTRODUCTION

AMPROBE PASAR is dedicated to designing, manufacturing and marketing high quality, reliable Instruments for the skilled professional. The AMPROBE PASAR Current Tracer has a history of providing safe, reliable operation in tracing energized wires, locating circuit breakers and locating wires shorted to the ground. The AMPROBE PASAR Open Tracer has the capability of tracing unenergized wires, locating open breakers and locating open wires.

The AT-2000 Advanced Tracing System combines both Current Tracing and Open Tracing into one versatile tool providing the ability to solve virtually all your tracing problems.

Having confidence in an instrument is an important part of using the instrument. All applications are different and special. An understanding of the system's operation could be the difference between several minutes or several hours on the job.

Invest time learning the operation of the Advanced Tracer to build confidence in the unit. Please read this manual carefully. Take the time to learn how the instrument operates. Test it in a variety of situations. You will soon have the confidence to use it on a daily basis to solve problems which were previously unsolvable.

AT-2000 SERIES PRODUCT DESCRIPTION

The AT-2000 System consists of different, yet fully compatible components that are combined into four interchangeable systems:

AT-2001 Commercial Circuit Tracer- includes R2000 Receiver and S2300 Load Signal Generator (9-300 volts AC or DC).

AT-2002 Industrial Circuit Tracer- includes R2000 Receiver and S2600 Load Signal Generator (9-600 volts AC or DC).

AT-2003 Commercial Open Tracer- includes R2000 and T2200 Transmitter.

AT-2004 Industrial Multipurpose Tracer- includes R2000, S2300, and T2200 Transmitter.

AT-2005 Industrial Multipurpose Tracer- includes R2000, S2600 and T2200 Transmitter.

All above tracer are delivered in the carrying case CA-200. Available is also the large case CC-2000 for the Clamp-On Accessory A-2201, the B2024 Battery Booster and B2025 Recharger

Accessory:

- B2024 Battery Booster
- B2025 Recharger
- A-2201 Inductive clamp
- ATGC-1 Ground Coil
- CC-2000 Carrying Case large

LIMITED WARRANTY

Congratulations! Your new instrument has been crafted according to quality standards and contains quality components and workmanship. It has been inspected for proper operation of all of its functions and tested by qualified factory technicians according to the long-established standards of our company.

Your instrument has a limited warranty against defective materials and/or workmanship for one year from the date of purchase provided that, in the opinion of the factory, the instrument has not been tampered with or taken apart.

Should your instrument fail due to defective materials, and/or workmanship during this one year period, a no charge repair or replacement will be made to the original purchaser. Please have your dated bill of sale, which must identify the instrument model number and serial number and call the number listed below:

Amprobe Repair Department
Phone: +49 (0)2161 – 59906-0
Fax: +49 (0)2161 – 59906-16

COMPONENT DESCRIPTION

R2000 Receiver

Has two built in detector that are tuned to pick up the 32.768khz signals generated by any of the other devices in the AT-2000 family: S2300, S2600, T2200, A2201. The R2000 is designed to display the signal's strength to enable quick locating of the conductor carrying the signal.

Mode Adjustment Switch

'OPEN' mode is used for open conductors. 'SHORT' mode is used on conductors that make up a complete circuit.

Range Switch

Coarse sensitivity adjustment

Battery light

Will illuminate when unit is turned 'on' provided the battery is in place and charged

Lanyard Attachment Hole

attach a wrist strap to prevent accidental dropping



Electromagnetic and Electrostatic detectors located In tip

Signal Strength Indicator
10 LED's positioned behind a red filter lens to allow readability in direct sunlight

Sensitivity Adjustment/ON-OFF thumbwheel

On -Off switch combined with fine adjustment of sensitivity

Battery Compartment
Drop-In-And-Close design automatically connects battery with the contacts. Battery must be oriented properly to allow it to close

Fig.1

Changing Batteries

The battery compartment on the back of the R2000 and the T2200 is a new design that allows you to drop the battery in and out quickly and easily. Two holes on the bottom of the compartment accept the round terminals of a 9 volt battery. The compartment is designed to accept the battery 180° and try again.

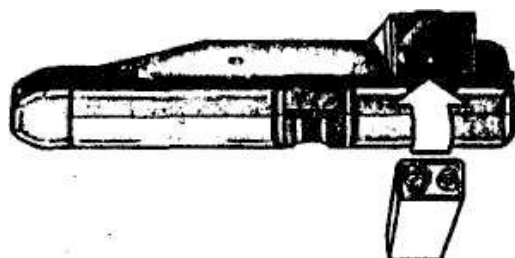

Fig.2

Using the R2000 Receiver

1. Turn the R2000 'ON' by rotating the thumbwheel and leave it around position '5'.
2. Move the range switch to x1 (this is the least sensitive setting).
3. Place the mode switch into the appropriate position and aim the R2000 properly (see illustration below).
4. If there is no indication on the display, increase the sensitivity by moving the range switch to x10 or x100. The thumbwheel is used as a fine adjustment to maintain a midrange indication (3-9 LED's).

IMPORTANT: Always try to keep the sensitivity low enough to a maximum of 9 LED'S on the indicator. Otherwise, you could waste a lot of time determining the proper signal source - a weak signal may register 10 LED'S in the x 100 range, but so will a strong signal (typically the one you want to follow).

5. When tracing, move the R2000 back and forth over the path of the wire and adjust the sensitivity so that you can see the rise and fall of the signal level. The strongest signal confirms the path of the wire.

NOTE: The R2000 will experience electromagnetic saturation when held up against wires carrying more than 500Amps. If this occurs, the signal strength indicator will go black. To remedy this, simply move the R2000 a few inches away from the wire.

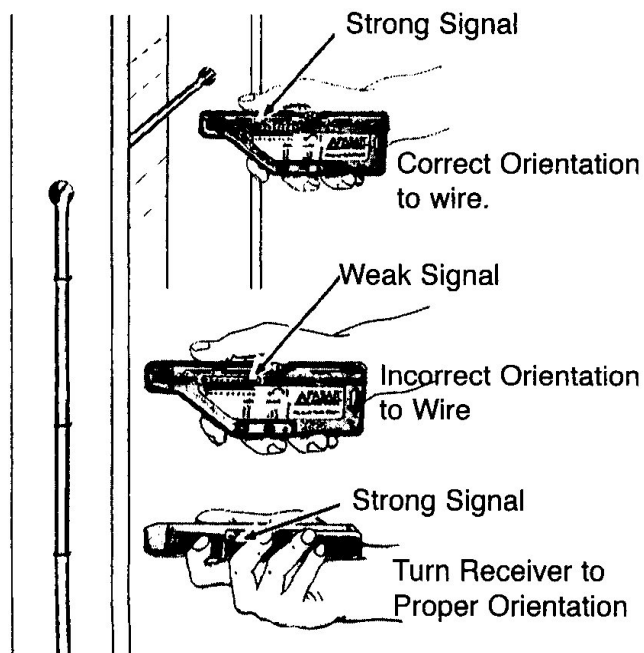

Fig. 3

In the 'SHORT' mode, orient Receiver so that is perpendicular to the wire.

Example:

Horizontal wire- thumbwheel should face up;

Vertical wire- thumbwheel should face either left or right.

S2300 and S2600 Load Signal Generators (LSG's)

When connected to an energized circuit, the LSG's will rapidly turn themselves on and off. This causes a slight, periodic current fluctuation that causes the power line to emit its own, trace-able signal, this signal can be detected all the way back to the main generator. However, the signal will not interfere with any sensitive electronic equipment and does not require power interruption.

S2300- For use on 9 to 300 volts AC or DC circuits only.

S2600- For use on 9 to 600 volts AC or DC circuits only.

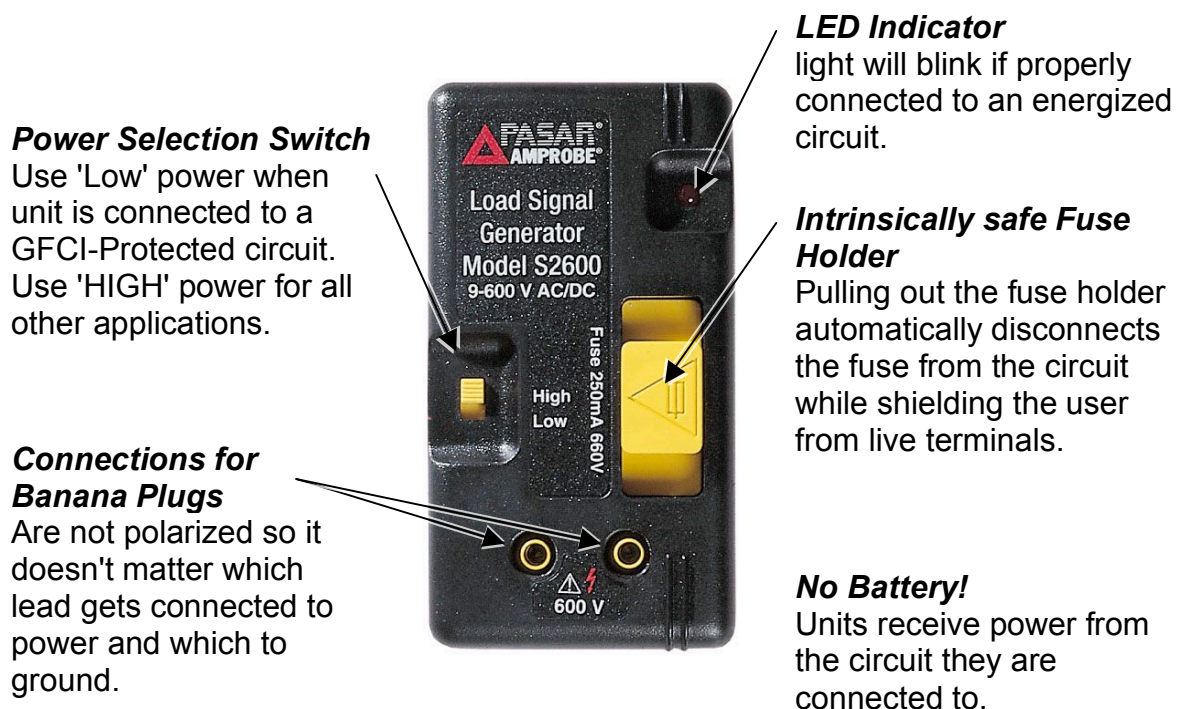
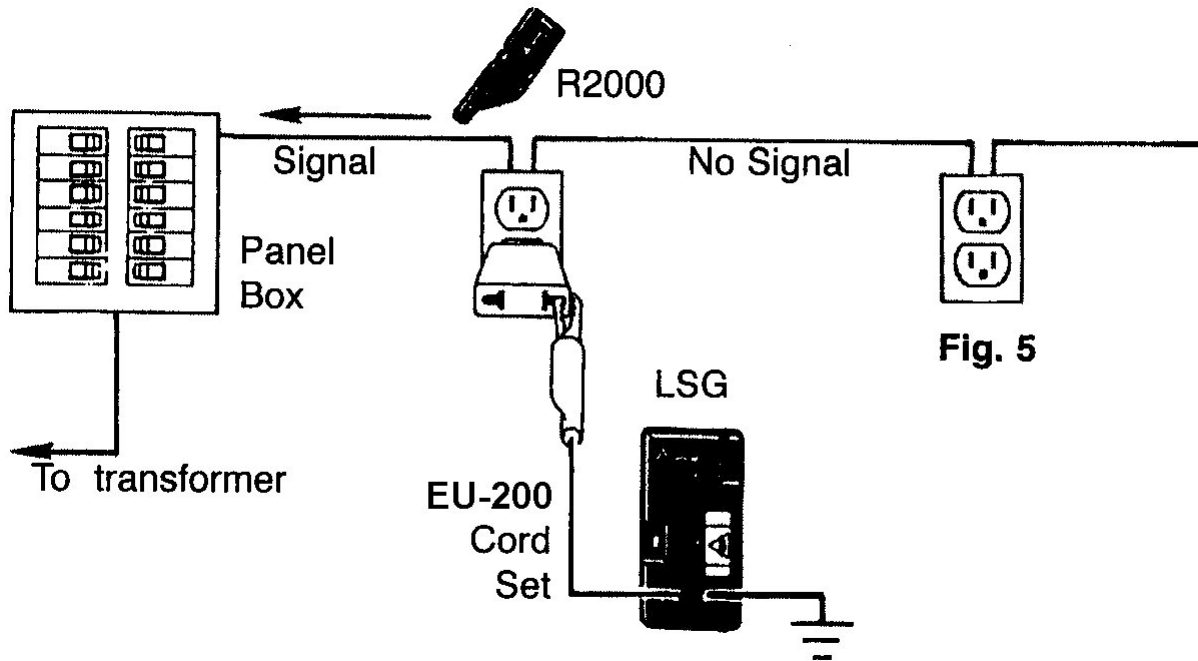

Fig.4

Both units are intrinsically safe and have a special 'LOW' - power setting used when tracing GFCI- protected circuits.

As their name implies, when connected to a circuit as a load, the LSG's cause the power line to generate a signal. The signal will be present anywhere between the LSG and the power source (line side or 'upstream') - no signal will be present on wiring on the other side of the LSG (load side or 'downstream'). For example, an LSG connected to a circuit breaker will produce no signal on that circuit. It will, however, cause a signal to be generated between that panel and the transformer.... and beyond.

NOTE: The signal strength after transformer will decrease according to its stepdown ratio.



The signal that generated is present at all points around the circuit. An LSG connected to a 220V outlet via the EU-200 cordset (thrust with the 220V) will cause an incoming signal on the neutral wire as well as an outgoing signal on the hot wire. The close proximity of these two wires may cause the signals to cancel each out, making it difficult to trace the cable in these areas (increasing the sensitivity will help detect the signal).

At the panel, the hot wire is separate from the neutral wire (where it's grounded) allowing easy circuit breaker identification. So, if tracing the branch wiring through the walls is not necessary, using the EU-200 cordset may be quicker to connect.

To trace downstream (load side) wiring, see Application Notes, page 20.
R2000 Signals Cancel

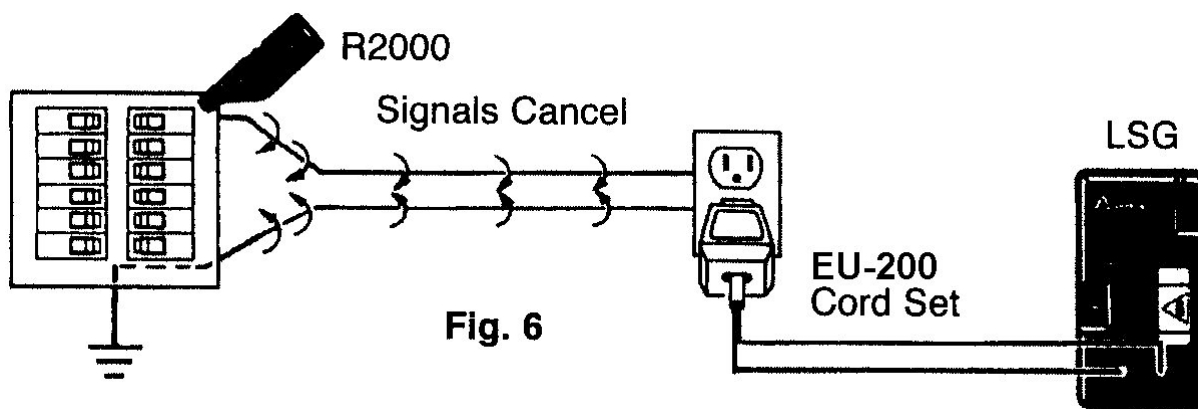

Easy tracing of wires and buried cable is accomplished by **simply separating wire from the return path (ground)**. Instead of using the neutral wire or the conduit as the ground, use the EU-200 Alligator clip cordset and attach one clip to separate ground such as a water pipe or a ground rod. A blinking light indicates a completed, functioning circuit.

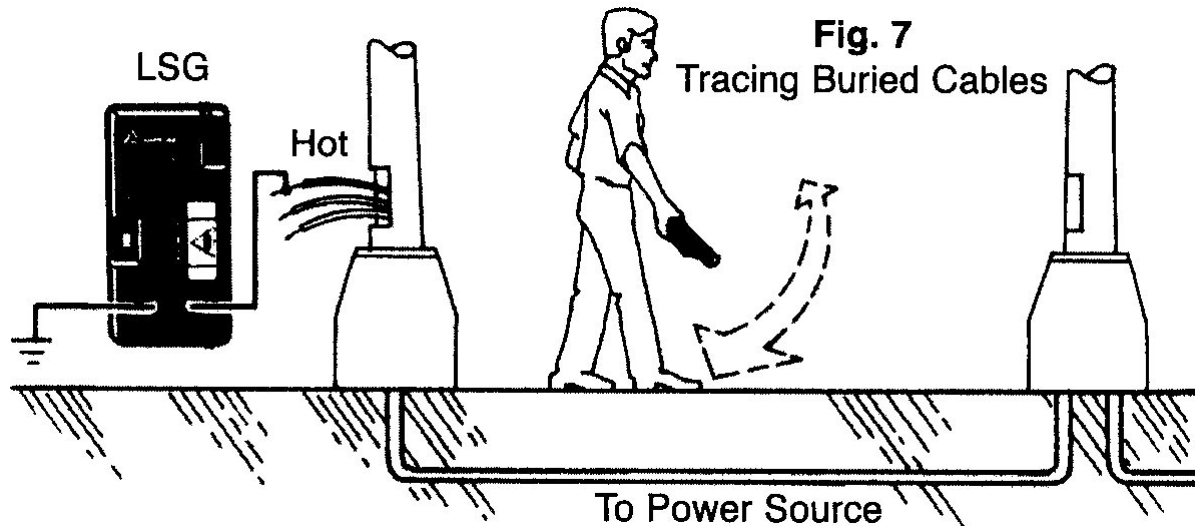

Using the S2300 and S2600 Load Signal Generators (LSG's)

- 1. Make sure the voltage does not exceed the rating of the LSG.***
- 2. Always connect the banana plugs to the LSG before connecting to the circuit.*** Use the cordset (EU-200) when the task is to identify which 220V breakers control certain receptacles. Use the alligator clip for all other applications.
- 3. Set power switch to 'High' when not tracing GFCI-protected circuits.***
- 4. Light will blink if circuit is complete and energized.***

T2200 Transmitter

The T2200 injects a signal onto a conductor. This signal will travel along the conductor until it ends. Primarily used for finding breaks in hidden or buried conductors, the T2200 will also allow you to trace wires and locate shorts as long as the lines are unenergized.

On an open line, no current will flow, so the injected signal will present itself as a voltage spike along the wire which is detected by the R2000 in the 'OPEN' mode. When the conductor is part of a complete circuit, the voltage causes a current to flow which produces a signal that is detected in the 'SHORT' mode.

Contains a 9V battery. A 24V input jack accepts the B2024 rechargeable battery or the B2025 220V converter, both for use when a very strong signal is necessary.

Intrinsically Safe Fuse Holder

Pulling out the fuse holder automatically disconnects the fuse from the circuit while shielding the user from live terminals.

Mode Switch

'High', 'MED', and 'LOW' voltage setting used to match the impedance of the line. Set at maximum signal level received on wire.

On/Off Switch

Turn 'OFF' when not in use.



Banana Plug Jacks Non-polarized

'ON Indicator Light

24 Volt Jack

For use with the B2024 battery Pack or the B2025 Converter to boost the T2200 output.

Easy Access Battery Compartment

See 'Changing Batteries', Page 6.

Fig.8

Using the T2200 Transmitter

- 1. Check to make sure there is no voltage on the conductor you wish to trace.**
- 2. Using the alligator clip cordset, connect the banana plugs to the transmitter.**
- 3. Connect one alligator clip to the wire you wish to trace (it doesn't matter which one as the input plugs are not polarized) and the other one to separate ground.**

4. Select power level and switch to 'ON' - The light should blink.
5. Trace the wire with the 2000. The signal will stop at the break in the wire.

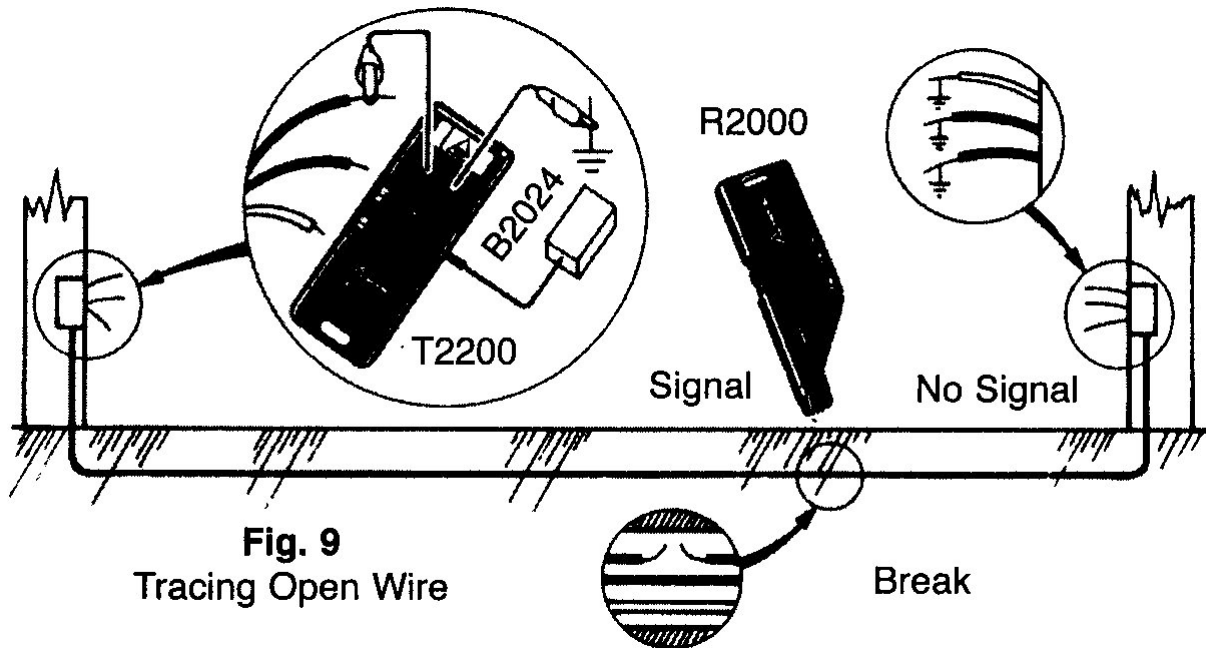

A2201 Clamp-On Transmitter Accessory

Enables the T2200 to induce its signal onto an unenergized or energized circuit. Plug the A2201 into the T2200 and clamp it around any conductor in an unenergized circuit, or the hot wire in an energized circuit. The signal will be induced on top of the 50 Hz frequency which may be present. The A2201 acts like a 1/2 Volt battery when clamped around a conductor. On a complete circuit this voltage will cause about 80mA of current to flow on top of whatever frequency is present.

To increase the signal strength, loop the wire around the clamp a few times or use the B2024 Battery Pack. The A2201 will allow wire tracing without the need for direct connection.



Fig.10

Using the A2201 Clamp-on transmitter Accessory

The A2201 will allow non-contact signal indication onto energized or non-energized conductors. On energized lines, the signal will propagate downstream to the end of the circuit, provided there is current flowing in the circuit. Unenergized lines must be grounded at both ends or made into a complete circuit. The signal strength can be boosted significantly by using the B2024 Battery Pack. One typical application for the A2201 is to access the hot wire at the panel in order to identify the 'downstream' loads:

1. Plug A2201 into T2200. Set mode switch to 'HIGH'.
2. Clamp the A2201 around the 'hot' wire.
3. Set the R2000 to 'OPEN' mode and trace the downstream wiring. To trace buried lines, switch to 'SHORT' mode (see Application Note, page 20).

B2024 Battery Pack

24 Volt Nickel-Cadmium recharge-able cell custom designed for light weight, small size, and durability. Used to boost the output of the T2200: Consult the specs for the boost levels. Includes a self-reset-table fuse.

Be sure to charge fully before use.



Fig.11

B2025 220V Converter/Recharger

Can be used to either recharge the B2024 or directly boost the T2200. To recharge the battery, leave it connected for at least 8 hours.



Fig12

EU-200 sensing lines with test prods and alligator clips

Fig. 13

APPLICATION NOTES***Finding Opens***

'Opens' are dead-end conductors that are not connected to anything and therefore do not pass current.

To find an open, use the T2200 transmitter, R2000 Receiver, and the alligator clip cordset. See fig. 9 on page 12.

1. Verify that there is no voltage on the conductor you wish to trace.
2. Plug the two banana plugs into the T2200.
3. Connect the other alligator clip to a separate ground.
4. Connect the other alligator clip to the conductor.
5. Where possible, ground any other conductors sharing the same path as the open wire.
6. Set mode switch to 'LOW'.
7. Turn the R2000 'On' by rotating the thumbwheel.
8. Switch to 'OPEN' mode and the x] sensitivity setting. Note: if the conductor is buried in moist soil, the 'SHORT' mode will give better results.
9. Move the R2000 down the wire a few feet and adjust the sensitivity until 5 to 9 LED's are lit. Move the T2200's mode switch to 'MED' and then 'HIGH' and leave it at the setting that causes the strongest

signal on the R2000.

10. Starting from the T2200, trace the conductor. When in the 'SHORT' mode, be sure to rotate the R2000 while tracing to maintain proper orientation in case the wire changes direction. The open will be at the point you begin to lose the signal.
11. Repeat process starting from the other end of the wire to verify the location of the open.

If you end up tracing the entire length of the wire without locating the open, you may be experiencing capacitive coupling, or 'signal bleed-off' onto the adjacent conductors. This condition may be alleviated by: a) grounding all adjacent conductors; b) minimizing the distance between the point of connection and the open.

If another conductor is connected to the first conductor somewhere along its length, the signal will split between them, causing both conductors to emit half the signal each. The B2024 battery or the B2025 converter can be used to increase the signal strength.

Finding Ground Faults

A ground fault is a direct connection of the conductor to ground. A typical ground fault may cause a tripped circuit breaker or a blown fuse (in contrast to an 'open', which passes no current). In this situation, a battery can be used as the current source. The battery can be any voltage over 9V, however, higher voltage will be more likely to overcome a high resistance fault and will produce a stronger signal (several 9V batteries in series work very well).

Also, you can use line voltage as the power source by connecting the LSG across the breaker.

1. Plug the alligator clip cordset into the LSG.
2. Attach one clip to the faulted wire and the other to one terminal of a battery (minimum 9V), or the hot side of the breaker.
3. If using a battery, connect the other battery terminal to ground.
4. The light on the LSG should blink indicating a complete circuit. If possible, ground all adjacent conductors.
5. The R2000 receiver can then be used to trace the wire. The signal should remain relatively constant until you pass the ground fault. At the fault, the signal from the LSG will pass from the wire and disperse into the ground. For this reason, the signal strength will decrease gradually (within 2-3 feet) so you will have to watch the LED's carefully in order to get within a few inches.

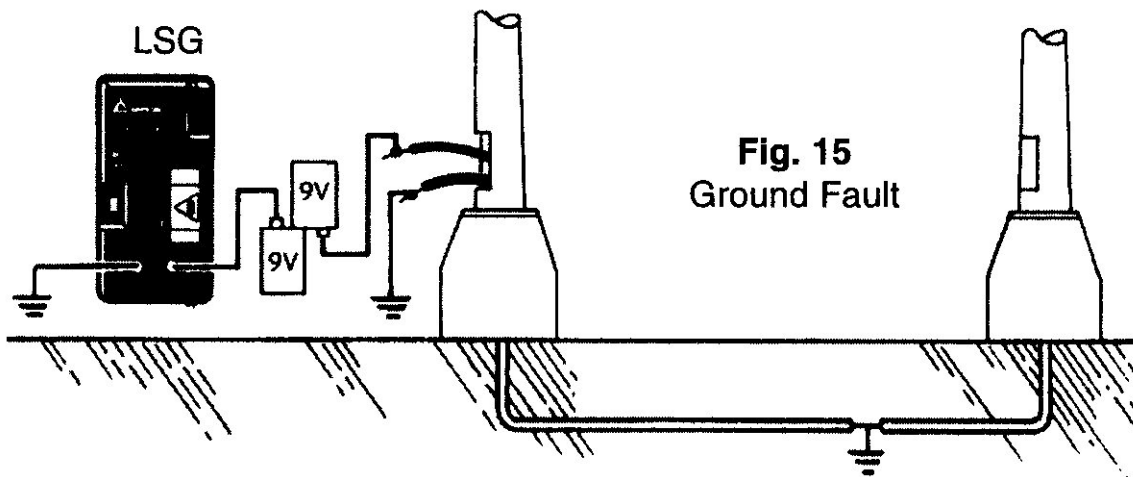

Tracing Wires in Conduit

When seeking a ground fault within metal conduit, the 'ground' is the conduit. Connect the battery to the conduit to complete the circuit. Steel conduit will tend to attenuate the signal strength so tracing will require higher sensitivity levels and access to within a few feet of the conduit. Aluminum conduit will severely attenuate the signal sometimes blocking all the signals from the wire. In this situation, steel couplings and junction boxes will transmit a signal. It may be necessary to periodically access the wire in the conduit to confirm signal presence.

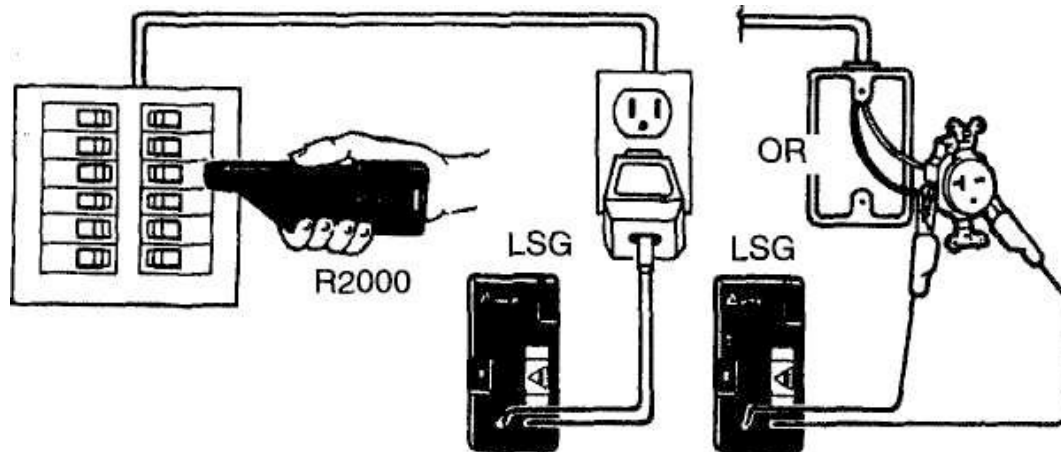

Fig. 16

Identifying Circuit Breakers

Locating Circuit Breakers or Fuses

Caution: Always check to make sure the line voltage DOES NOT EXCEED the range of the LSG - S2300: 9-300V, S2600: 9-600V.

1. Connect the LSG to the circuit as shown using either the C2901 Pigtail Cordset for 220V receptacles or the C2902 Alligator Clip Cordset. The light will blink.
2. Turn the Receiver on by rotating the thumbwheel and leave it around position '5'. The battery light should be on.
3. Set range to x1, and the mode switch to 'SHORT'.
4. Move the Receiver in front of the outside of each circuit breaker, as shown, to determine which one has the strongest signal. Use thumbwheel to reduce the sensitivity when the signal strength goes above 9 LED's and leave it in this position until you come across another breaker with a stronger signal. In this way you can accurately determine the proper breaker.
5. If two or more breakers produce the same signal strength indication, remove the panel cover and test each wire, reducing the sensitivity where necessary.

Tracing Energized Wires

(Also see "Locating Outlets from the Breaker Panel", page 20)

1. Connect the alligator clip Cordset to the LSG.
2. Make sure the voltage does not exceed the LSG's rating.
3. Connect one alligator clip to the hot wire and other to a separate ground (not something that runs along the same path as the hot wire). At a receptacle, use the AD-1 Adapter to access the hot wire). At a

receptacle, use the AD-1 Adapter to access the hot wire and the water pipe or such for the ground, as shown in fig. 5 on page 9.

4. Starting at the lowest sensitivity setting, x1, circle the area with the R2000 in the 'SHORT' mode.
5. Increase the sensitivity, if necessary, to locate the path of the wire.
6. Follow the signal path, keeping the sensitivity as low as possible and adjusting the R2000's orientation periodically to check for bends in the wire (Fig. 3 on page 7).

Tracing Unenergized Lines and Finding Shorts

If the wire you wish to trace is part of a complete circuit, or can be made into a complete circuit easily, use the following procedure. If it is not part of a complete circuit then use the "Finding Opens" procedure on page 14.

There are two methods that you can use:

1. A) Connect alligator clip Cordset to ILSG.
 - B) Attach one alligator clip to the wire you wish to trace and the other to one terminal of an AC or DC power source (one or two 9V batteries work fine).
 - C) Connect the other battery terminal to the other side of your circuit:
 - a. For line to neutral faults, connect to neutral wire.
 - b. For grounded wires, connect to a suitable, separate ground.
 - D) If the LSG blinks, then you have a complete circuit.
 - E) Turn the R2000 'ON' and switch to 'SHORT' mode.
 - F) Trace the wire –
 - a. In the case of finding shorts, follow the cable path until you lose all the signal. That will be the location of the short.
 - b. In all other cases, follow the wire path to its end.

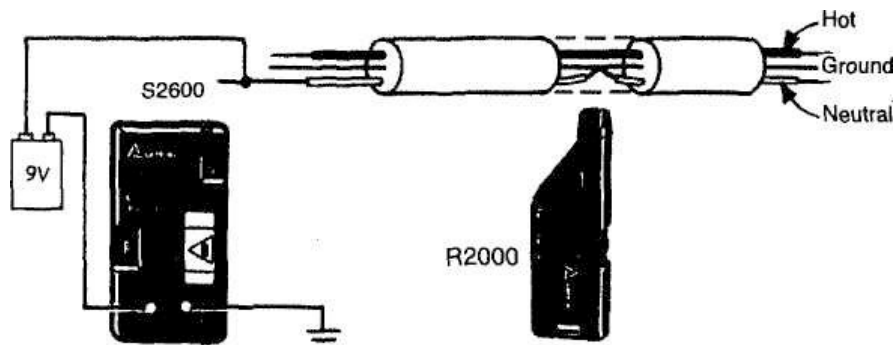

Fig. 17
Short to Ground

2. A) Connect the alligator clip cordset to the T2200.
- B) Attach one clip to one wire and the other to the circuit's return path (for a line to neutral short, use the neutral wire).
- C) Turn the T2200 'ON' and switch to 'LOW'.
- D) Turn the R2000 'ON' and switch to 'SHORT' mode.
- E) Hold the R2000 near the wire, 2-3 feet from the connection.
- F) Adjust the sensitivity to get 3-9 LED's.
- G) Switch the T2200's mode switch to 'MED' and then 'HIGH' and leave it at the position that registers the highest reading on the R2000.
- H) Trace the wire.

Locating Individual Wires in a Bundle

A. Energized Lines

1. Attach alligator clip Cordset to the ILSG.
2. Verify that voltage on the line does not exceed LSG's rating.
3. Connect one alligator clip to the wire you wish to identify and the other to a separate ground.
4. Turn R2000 'ON' and leave thumbwheel in position '5'.
5. Set mode switch to 'SHORT' and sensitivity to x1.
6. At bundle, pull each individual wire away from the other wires and touch to R2000 tip.
7. The strongest signal indicates the proper wire.

NOTE: In some instances, capacitive coupling may occur which can cause other wires to emit the signal, making it difficult to identify the proper wire. In this situation, switch the LSG to 'LOW' and try again, If this doesn't work, disconnect power and use a 9V battery as the power source and attach similar to the 'ground fault' set-up.

B. Unenergized Lines

Same procedure as "Tracing Unenergized Lines" except, at the bundle, proceed as in step 6 on previous page.

Locating Outlets from the Breaker Panel

If possible, have current flowing in the circuit while tracing. If circuit is not already in use, plug something in to it.

1. Connect the A2201 Clamp-on to the T2200 Transmitter and then clamp it around the conductor.
2. Set the T2200 to 'HIGH' mode.
3. Set the R2000 to 'OPEN' mode, x10 range, and turn thumb wheel to '5'.
4. If you do not have the B2024 Battery Pack, increase the sensitivity to the x1 00 range.
5. Hold the R2000 in front of each suspected outlet or piece of equipment. If it is on the same wire as the Clamp, the R2000 will indicate it.
6. If a known outlet does not produce a signal, increase the sensitivity on the R2000. If this doesn't work, check to make sure the battery is charged.

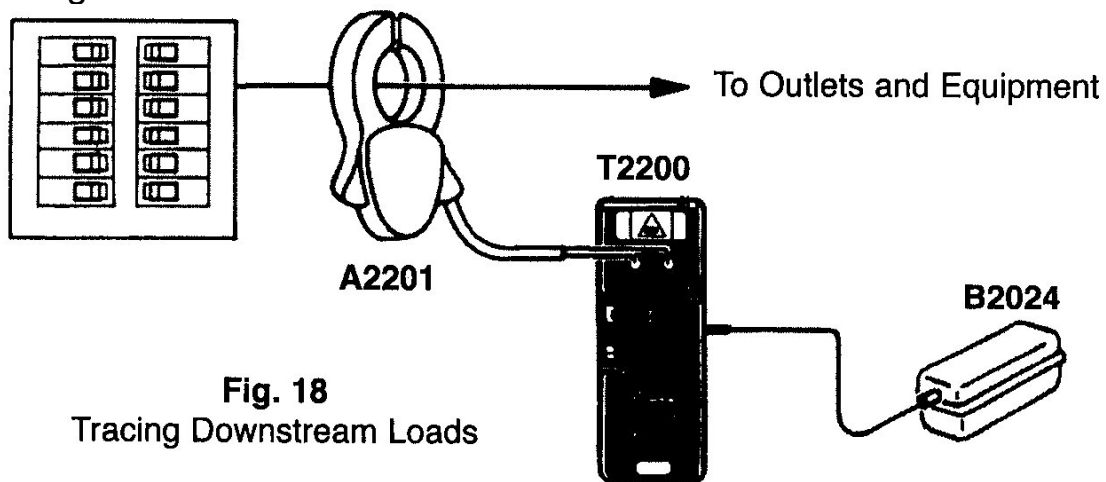

Fig. 18
Tracing Downstream Loads

Locating Buried Conduit or Metal Pipe

1. Connect the A2201 Clamp to the T2200 transmitter and then clamp it around the conduit or pipe.
2. Use the B2024 battery or the BV2025 Converter is recommended. Plug either one into the jack on the side of the T2200.
3. Set the T2200 to 'higher' mode.
4. Set the R2000 to 'short' mode, x 10 range and turn thumb wheel to 5'.
5. Trace the conduit (see page 7 for technique).

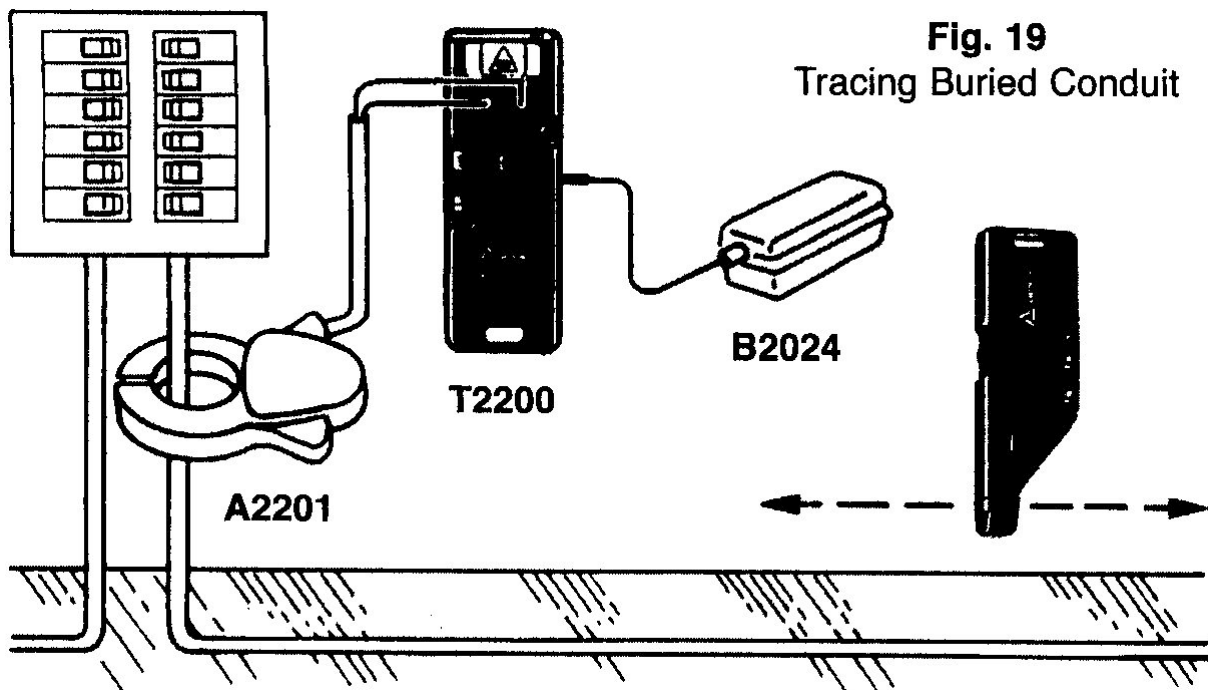

Fig. 19
Tracing Buried Conduit

SPECIFICATIONS

General

Operating Temperature: 0 to 120° F (-18°C to 49°C)

Storage Temperature: -40 to 150° F (-40°C to 66°C)

Case Material: ABS

Case Size: 11"x15"1/2" x 4" (39.4 x 27.9 x 10.2 cm)

R2000 Receiver

Detectors: Electromagnetic coil pickup for short mode.

Electrostatic plate pickup for open mode.

Sensitivity Selection: x1, x10, x100 course gain adjustment;
0-10 fine adjustment.

Short Mode performance: Over 20 feet in air under test conditions

Open Mode Performance: Over 12 feet in air under test conditions

60Hz Rejection: 120db

Power Source: 9V alkaline battery

Display: 10 LED's with chroma filter lens

Case: Flame retardant ABS 911

Weight: 6.2 oz (176grms)

S2300 Load Signal Generator

Operating Voltage: 9-300 volts AC or DC

Operating frequency: 32.768 KHz

Duty Cycle: Transmits 2 pulses with a duration of 0.0625 each every
0.5 seconds

Current Output-

Low Mode: 35mA peak, 4mA average

HIGH Mode: 70mA peak, 6mA average

Fuse: Fast acting 250mA @ 380V (6mm x 32mm)

Cat. No. 380.25-6x32

Case: Flame retardant ABS 911

Weight: 3.7 oz (105 grams)

S2600 Load Signal Generator

Operating Voltage: 9-600 volts AC or DC

Operating Frequency: 32.768 KHz

Duty Cycle: Transmits 2 pulses with a duration of 0.0625 each every 0.5 seconds

Current Output-

Low Mode: 35 mA peak, 4mA average

High Mode: 70 mA peak, 6mA average

Fuse: Fast acting 250mA @ 660V (6mm x 32mm)
Cat. No. 660.25-6X32

Case: Flame retardant ABS 911

Weight: 3.8 oz (108 grams)

T2200 Transmitter

Operating Frequency: 32.768 KHz

Duty Cycle: Transmits 2 pulses with a duration of 0.0625 each every 0.5 seconds.

Signal Output:

	<u>9V supply</u>	<u>24V supply</u>
High Setting:	1A, 31V	3A 105V
Medium Setting:	1.8A, 13V	6A 45V
Low Setting:	3.0A, 6.5	10A 22V

High Setting: 1A, 31V 3A 105V

Medium Setting: 1.8A, 13V 6A 45V

Low Setting: 3.0A, 6.5 10A 22V

Fuse: Fast acting 2A @ 250V 3AG 1/4" x 11/4"
Cat No. No. 2502-6x32

Battery: 9V alkaline- 24V jack will accept battery pack accessory
(B2024 or B2025)

Case: Flame retardant ABS 911

Weight: 6.4 oz (182 grams)

A2201 Clamp-on Transmitter Accessory

Operating Frequency: 32.768 KHz as supplied by the T2200

Case Breakdown Voltage: 3000 volts

Maximum Wiresize: 2000 MCM or 2" dia. cable

Battery: None, power is supplied by T2200

Weight: 9.9 oz (281 grams)

B2024 Battery Pack

Type: Nickel-Cadmium Rechargeable (20AA cells)

Capacity: 24Volt, 600 mah

Recharge Time: 14 hours

Fuse: Internal self-resetting

B2025 Recharger/Converter

Input: 115VAC

Output: 24VDC @ 350 mah

