

Digi Connect ME[®] 9210 Family

Compact and powerful wired and wireless embedded modules

Ultra-compact high-performance embedded modules for M2M networking combine on-chip security and integrated 802.11b/g/n Wi-Fi or Ethernet networking.



Overview

The Digi Connect ME 9210 family of embedded modules enables secure wired and wireless networking. Built on Digi's powerful NS9210 ARM9 processor, these high-performance modules allow customers to implement next generation network-enabled products. Additionally, their RJ-45 form factor is pin compatible with modules in the Digi Connect ME family.

These modules can provide future application-specific interface options through the programmable Flexible Interface Module (FIM), while keeping the main serial port or other key peripheral interfaces available. They are well-suited for more advanced core module applications by supporting up to ten shared GPIOs, external IRQs and an extended set of peripheral interface options.

The Digi Connect ME 9210 family features the development and operational benefits of the Device Cloud by Etherios[™]. This secure, highly-scalable platform seamlessly ties enterprise applications and remote devices together. Using Device Cloud, customers can also easily configure, upgrade, monitor and troubleshoot their devices from a centralized location.

Platforms and Services



Design Services



Accessory Kits



Support

NET + OS



Supported Software Platforms

Block Diagram

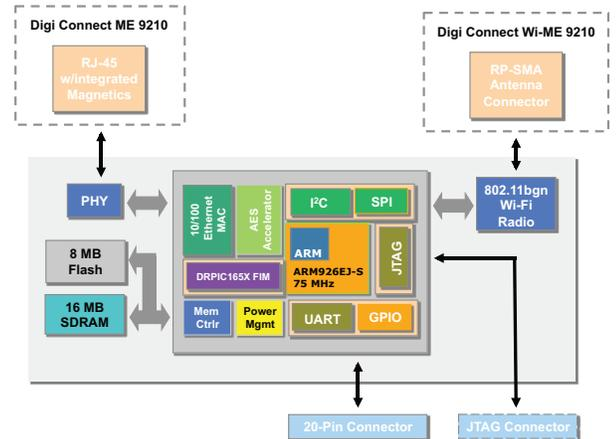

Features/Benefits

- Secure 802.11b/g/n Wi-Fi support
- Integrated 10/100 Mbit Ethernet interface
- Support for Digi Embedded Linux and Digi NET+OS
- Industrial operating temperature System-on-Module
- RJ-45 form factor compatible with Digi Connect ME
- On-chip hardware encryption engine
- Extended set of on-chip interfaces and signals
- Power management modes
- Low-emission design (FCC Class B)
- Seamless migration to NET+ARM chip design



Development Kits

Digi JumpStart Kits® Overview

Digi JumpStart Kit® for NET+OS

This royalty-free turnkey solution for embedded software development is based on the ThreadX Real-Time Operating System (RTOS), one of the most reliable and field-proven RTOS solutions available. In addition to ThreadX, NET+OS provides the integrated building blocks needed to create product solutions with leading network security using Digi embedded modules and microprocessors.

For professional NET+OS software development, the Eclipse based Digi ESP™ Integrated Development Environment (IDE) with graphical user interface and high-speed USB 2.0 hardware debugger is provided out-of-the-box.

- Royalty-free turnkey solution for embedded software development
- Built on field-proven and compact ThreadX RTOS
- Fully integrated support for secure, IPv4/IPv6 networking applications
- Professional software development using Windows-based Digi ESP IDE



Digi JumpStart Kit® for Embedded Linux

Built around a standard Linux 2.6 kernel distribution, the Digi JumpStart Kit for Embedded Linux is tailored to the specific needs of embedded Linux development and provides an easy-to-use, complete off-the-shelf embedded development platform. It includes all components that are required to build secure network-enabled products based on the Digi Connect ME 9210 family.

The kit includes Digi ESP™ for Embedded Linux, a powerful and fully Linux-hosted Integrated Development Environment based on the open Eclipse™ framework. Ideal for new and experienced Linux developers, Digi ESP improves software design productivity by accelerating and greatly simplifying driver and application development through a user-friendly graphical interface.

- Off-the-shelf development platform for network-enabled embedded systems
- Royalty-free and with optimized 2.6 kernel and services support
- Linux Digi ESP IDE for accelerated software development
- Full Linux and Digi BSP source code included



Digi Connect ME kits shown

Digi JumpStart Kits® Contents

Software Platform	NET+OS	Embedded Linux
Module	Digi Connect ME 9210 or Digi Connect Wi-ME 9210 w/ 8 MB Flash, 16 MB SDRAM	
Development Board	1 RS-232 serial port, GPIO configuration switches, screw terminal for GPIO signals, prototyping area, status LEDs (serial, GPIO, power), logic signal header, test points, reset button, user/wake-up buttons, PoE module header, 9-30VDC power supply, JTAG header and RS-232 console/debug port for JTAG-equipped modules	
CD/DVD	Digi NET+OS CD: NET+OS 7, Digi ESP IDE, BSP source code, sample code, Green Hills MULTI IDE support files, user documentation	Digi Embedded Linux 4 DVD: Digi Embedded Linux, Digi ESP IDE, Linux and platform specific source code, Universal boot loader source code (U-Boot), sample code, documentation
Documentation	Quick start guide, Digi ESP tutorial, NET+OS porting guide, NET+OS API documentation, Advanced Web Server, hardware reference manual, development board schematics	Quick start guide, Digi Embedded Linux user's guide, hardware reference manual, development board schematics
Power Supplies and Accessories	External wall power supply (110/240VAC) with interchangeable outlet adapters (North America, EU, UK, and Australia), crossover serial cable, Ethernet cable	
Other	Digi JTAG Link USB 2.0 hardware debugger	N/A
Kit Part Numbers		
Ethernet Only	DC-ME-9210-NET	DC-ME-9210-LX
WLAN + Ethernet	DC-WME-9210-NET	DC-WME-9210-LX

Please refer to the feature specs on our website for detailed information about the specific software platform capabilities.

Specifications

Digi Connect ME® 9210

Digi Connect Wi-ME® 9210

Hardware

Processor Type	32-bit Digi NS9210 processor	
ARM Core	ARM926EJ-S	
Processor Speed	75 MHz	
Cache	4k I/D Cache	
Memory Base Population	Support up to 8 MB NOR Flash Support up to 16 MB SDRAM	
Flexible Interface Modules (FIMs)	300 MHz DRPIC165X CPU; 2k program/192 bytes data RAM	
On-chip 256-bit AES Accelerator	•	
Power Management Modes	On-the-fly clock scaling; Low-power sleep modes; Configurable scaling/wake-up events (EIRQ, UART, Ethernet, etc.)	
Pins/Form Factor	RJ-45 connector style with 20-pin micro pin header (Samtec FTS-110-01-F-DV-TR)	
High-Speed TTL Serial Interface	Full signal support (TXD, RXD, RTS, CTS, DTR, DSR and DCD); Hardware/Software flow control	
GPIO	10 shared; Up to 3 external IRQ options	
SPI	Master data rate up to 16.7 Mbps; Slave data rate up to 7.5 Mbps	
I ² C	v1.0 bus interface; 7-bit and 10-bit address modes	
Flexible Interface Support (FIM)	UART, 1-Wire, USB device (low-speed), CAN BUS	
Watchdog Timer (16-bit)	•	
JTAG Interface	Available on development modules only	
On-Board Power Supervisor	•	
Wave-Solderable Design	No clean flux process	
Dimensions (L x W x H)	1.445 in (36.7 mm) x 0.75 in (19.05 mm) x 0.735 in (18.67 mm)	

Network Interface - Wired

Physical Layer	10/100Base-T	N/A
Data Rate	10/100 Mbps (auto-sensing)	N/A
Mode	Full- or half-duplex (auto-sensing)	N/A
Connector	RJ-45 w/ magnetics	N/A
PoE Power Pass-Through	802.3af compliant (Mid- and End-span)	N/A

Network Interface – Wireless LAN

Standard	N/A	IEEE 802.11b/g/n
Frequency	N/A	2.4 GHz
Data Rate	N/A	Up to 65 Mbps with automatic fallback
Modulation	N/A	CCK (11/5 Mbps), DQPSK (2 Mbps), DBPSK (1 Mbps), OFDM (6, 9, 12, 18, 24, 48, 54 and 65 Mbps)
Typical Transmit Power	N/A	+17 dBm
Receive Sensitivity	N/A	-69 dBm @ 54 Mbps
Connector	N/A	1 x RP-SMA

WLAN Security

WEP (Wired Equivalent Privacy)	N/A	64/128-bit encryption (RC4)
WPA/WPA2/802.11i	N/A	128-bit TKIP/CCMP (AES) encryption. Enterprise mode (802.1X): LEAP (WEP only), PEAP, TTLS, TLS, EAP-FAST, GTC, MD5, OTP, PAP, CHAP, MSCHAP, MSCHAPv2, TTLS-MSCHAPv2. Pre-shared key mode (PSK/Personal).

Environmental

Operating Temperature	-40° C to +75° C (-40° F to +167° F) -40° C to +85° C (-40° F to +185° F) with external thermal pad*	
Storage Temperature	-50° C to +125° C (-58° F to +257° F)	
Relative Humidity	5% to 90% (non-condensing)	
Altitude	12,000 feet (3,658 meters)	

• Module Feature

*Please see hardware reference manual for detailed information

Power Requirements (3.3 VDC)

Maximum	450 mA (1.485 W)	
Typical	346 mA (1.14 W) UART and Ethernet activated	
Idle	186 mA (613 mW) /16 clock scaling, Ethernet activated	-
Sleep	3.3 VDC @ 34 mA (113 mW)	3.3 VDC @ 142 mA (486 mW)

Regulatory Approvals

FCC Part 15 Class B, EN 55022 Class B	•
EN 61000-3-2 and EN 61000-3-3	•
ICES-003 Class B, VCCI Class II, AS 3548	•
FCC Part 15 Sub C Section 15.247	•
IC RSS-210 Issue 5 Section 6.2.2(o)	•
EN 300 328, EN 301 489-17	•
UL 60950-1, EN 60950 (EU)	•
CSA C22.2, No. 60950	•
EN 55024	•
Intentional Radiation	•

• Module Feature

Module Pinout

Pin	UART	GPIO	Ext IRQ	I ² C	SPI	FIM	Other
1							VETH+
2							VETH-
3-6	Positions removed						
7	RxD	GPIO[3]			IN	PIC[3]	
8	TxD	GPIO[7]			OUT		Timer Out 7 Timer In 8
9	RTS	GPIO[5]	3		CLK		Timer Out 6
10	DTR	GPIO[6]					Timer In 7
11	CTS	GPIO[1]	0			PIC[1]	
12	DSR	GPIO[2]	1			PIC[2]	
13	DCD	GPIO[0]			EN	PIC[0]	
14							/RST
15							3.3V
16							GND
17		GPIO[12]		SDA	CLK		RESET_DONE
18		GPIO[9]	0	SCL			
19	Reserved						
20		GPIO[13]			CLK		INIT Timer Out 9

Recommended PCB Layout

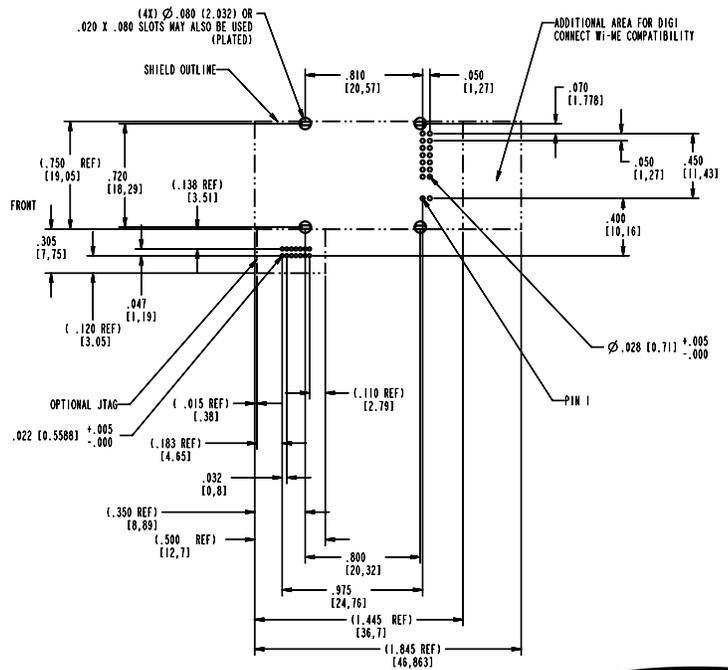

Visit www.digiembedded.com for part numbers.

DIGI SERVICE AND SUPPORT - You can purchase with confidence knowing that Digi is here to support you with expert technical support and a strong five-year warranty. www.digi.com/support

91001478
D4/1113

**Digi International
Worldwide HQ**

877-912-3444
952-912-3444

**Digi International
France**

+33-1-55-61-98-98
www.digi.fr

**Digi International
Japan**

+81-3-5428-0261
www.digi-intl.co.jp

**Digi International
India**

+91-80-4287-9887

**Digi International
Singapore**

+65-6213-5380

**Digi International
China**

+86-21-5150-6898
www.digi.cn

BUY ONLINE • www.digiembedded.com

© 2009-2013 Digi International Inc. All rights reserved. Digi, Digi International, Etherios, the Digi logo, the Device Cloud by Etherios logo, Digi Connect ME, Digi ESP, Digi JumpStart Kit, Device Cloud by Etherios, NET+ and NET+OS are trademarks or registered trademarks of Digi International Inc. in the United States and other countries worldwide. ARM and NET+ARM are trademarks or registered trademarks of ARM Limited. All other trademarks are the property of their respective owners. All information provided is subject to change without notice.

