

LENGTH TABLE

| MATERIAL NO. | NO. CIRCUITS | "E"            | "D"            | "C"         | "B"           | "A"          |
|--------------|--------------|----------------|----------------|-------------|---------------|--------------|
| 394260002    | 02           | 34.56 (1.361)  | 33.35 (1.313)  | 25.0 (0.98) | 12.00 (0.472) | 44.1 (1.74)  |
| 394260003    | 03           | 46.56 (1.833)  | 45.35 (1.785)  | 37.0 (1.46) | 24.00 (0.945) | 56.1 (2.21)  |
| 394260004    | 04           | 58.56 (2.306)  | 57.35 (2.258)  | 49.0 (1.93) | 36.00 (1.417) | 68.1 (2.68)  |
| 394260005    | 05           | 70.56 (2.778)  | 69.35 (2.730)  | 61.0 (2.40) | 48.00 (1.890) | 80.1 (3.15)  |
| 394260006    | 06           | 82.56 (3.250)  | 81.35 (3.203)  | 73.0 (2.87) | 60.00 (2.362) | 92.1 (3.63)  |
| 394260007    | 07           | 94.56 (3.723)  | 93.35 (3.675)  | 85.0 (3.35) | 72.00 (2.835) | 104.1 (4.10) |
| 394260008    | 08           | 106.56 (4.195) | 105.35 (4.148) | 97.0 (3.82) | 84.00 (3.307) | 116.1 (4.57) |

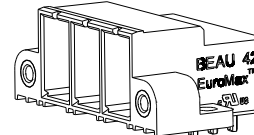

2 AND 3 CIRCUIT HEADERS  
HAVE NO "PRY SLOTS"

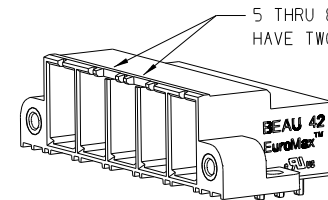

5 THRU 8 CIRCUIT HEADERS  
HAVE TWO "PRY SLOTS"

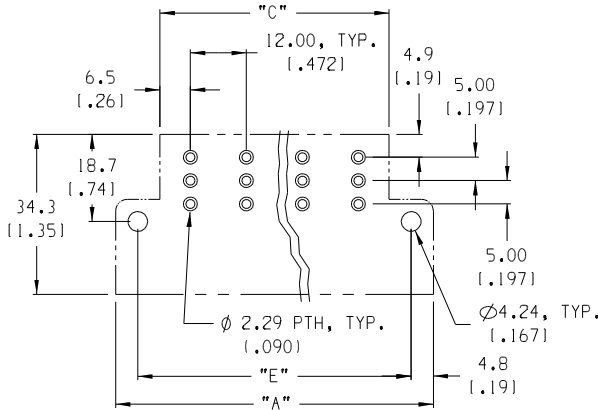

RECOMMENDED PTH PATTERN

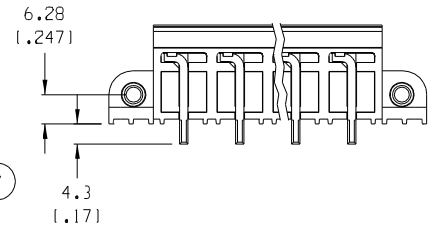
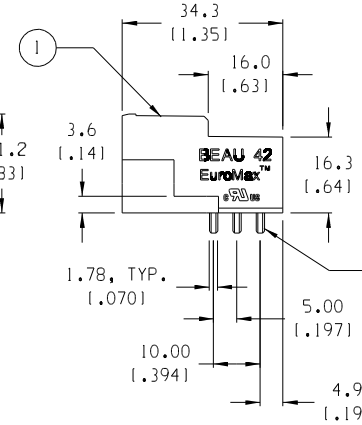
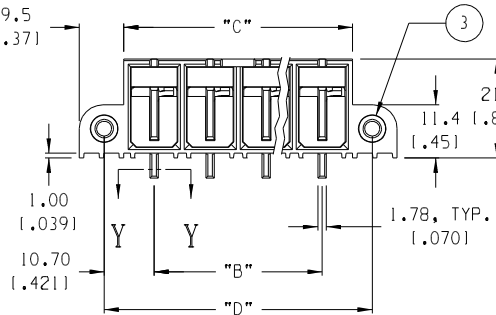
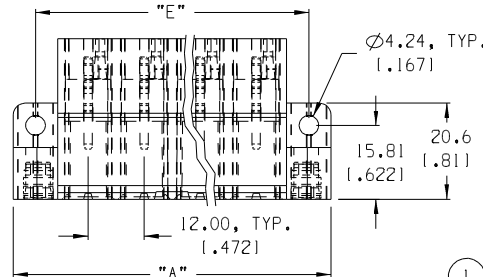

NOTES:

1. MATERIAL: SEE TABLE
2. FINISHES: SEE TABLE
3. PRODUCT SPECIFICATION: SEE PPS.42.001
4. PACKAGING: NOT REQUIRED
5. MATES WITH: 3942200XX PLUG
6. XX EQUALS NUMBER OF CIRCUITS

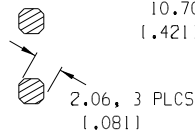

SECTION Y-Y  
SCALE 3:1

| ITEM | QTY. | DESCRIPTION     | MATERIAL | FINISH |
|------|------|-----------------|----------|--------|
| 3    | 2    | THD. INSERT, M4 | BRASS    | NONE   |
| 2    | XX   | BLADE CONTACT   | COPPER   | TIN    |
| 1    | 1    | MOLDING, HEADER | PBT      | BLACK  |

|        |          |       |          |
|--------|----------|-------|----------|
| EC NO. | RELEASED | RK    | 11-16-04 |
| DRWING | CHK'D    | APPR: |          |
| REV    | A        |       |          |

|                 |       |          |     |
|-----------------|-------|----------|-----|
| QUALITY SYMBOLS | MAJOR | CRITICAL | SPC |
|                 | ▲     | ▽        | △   |
| DESCRIPTION     |       |          |     |

|  |             |
|--|-------------|
| GENERAL TOLERANCES (UNLESS SPECIFIED)                |             |
| mm   | INCH        |
| 4 PLACES   | ±.0015      |
| 3 PLACES   | ±.038 ±.005 |
| 2 PLACES   | ±.13 ±.01   |
| 1 PLACE  | ±.3         |
| ANGULAR: ±2°   |             |
| DRAFT WHERE APPLICABLE MUST REMAIN WITHIN DIMENSIONS |             |

|                    |  |
|--------------------|--|
| SCALE              | DESIGN UNITS   |
| 1:1                | <input type="checkbox"/> mm <input checked="" type="checkbox"/> INCH |
| DRAWN BY & DATE    |  |
| R. KEMP 10-19-04   |  |
| CHECKED BY & DATE  |  |
| APPROVED BY & DATE |  |
| CAD FILENAME       |  |
| 4259XX             |  |

|  |                               |                                  |                    |
|--|-------------------------------|----------------------------------|--------------------|
| PROJECT NO. 03-65  |                               | -                                | -                  |
| DIMENSIONS:  |                               | SHT                              | REV                |
| <input checked="" type="checkbox"/> mm   | <input type="checkbox"/> INCH | <input type="checkbox"/> mm ONLY | REVISE ON CAD ONLY |
| TITLE:   |                               |                                  |                    |
| HEADER, 12MM, 85A, 600V,   |                               |                                  |                    |
| MOLEX INCORPORATED   |                               |                                  |                    |
| MATERIAL NO.   | DRAWING NO.                   | SHEET NO.                        |                    |
| SEE CHART  | SD-39426-001                  | 1 OF 1                           |                    |
| THIS DRAWING CONTAINS INFORMATION THAT IS PROPRIETARY TO MOLEX INCORPORATED AND SHOULD NOT BE USED WITHOUT WRITTEN PERMISSION. |                               |                                  | SIZE               |
|  |                               |                                  | B                  |