



AKD4112B

AK4112B Evaluation Board Rev.A

GENERAL DESCRIPTION

AKD4112B is the evaluation board for AK4112B, 96kHz digital audio transceiver. This has optical and BNC connector to interface with other digital audio equipment. The AKD4112B is also available to output analog data via on-board DAC, AK4394.

■ **Ordering guide**

AKD4112B --- Evaluation board for AK4112B
 (A cable for connecting with printer port of IBM-AT compatible PC
 and a control software are packed with this.)

FUNCTION

□ **Digital interface**

-S/PDIF :

4 channel input (optical or BNC)

1 channel output (optical or BNC)

- Serial audio data I/F :

1 output (for DIR data output. 10-pin port)

□ **Analog interface**

-DAC output :

Differential stereo output (Lch/Rch)

□ **10pin header for serial control interface**

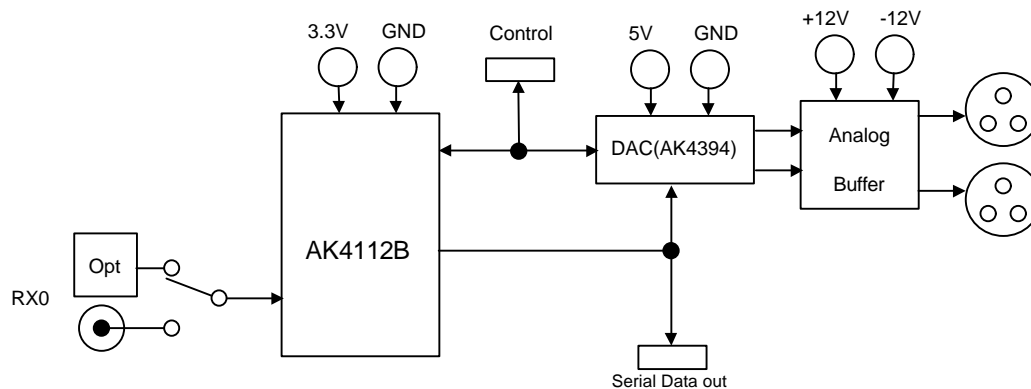

Fig 1. AKD4112B Block Diagram

*Circuit diagram and PCB layout are attached at the end of this manual.

■ Evaluation modes

- (1) Evaluation for DIR (Digital output)
S/PDIF in(optical or BNC) – AK4112B – Serial Data out(10pin port)
- (2) Evaluation for DIR(analog output via DAC)
S/PDIF in(optical or BNC) – AK4112B – DAC(AK4394) – Analog out(Balance XLR)

■ Operating sequence

(1) Set up the power supply lines.

[-12V]	(Blue)	= -12 ~ -15V	
[+12V]	(Orange)	= +12 ~ +15V	
[Analog 5V]	(Red)	= 5V	: Open when the JP15(REG5V) is short.
[AGND]	(Black)	= 0V	
[Digital 5V]	(Red)	= 5V	
[DGND]	(Black)	= 0V	
[Analog 3V]	(Green)	= 3.3V	: Open when the JP13(REG3V) is short.
[AGND2]	(Black)	= 0V	
[Digital 3V]	(Green)	= 3.3V	

Each supply line should be distributed from the power supply unit.

(2) Set up the evaluation mode and jumper pins. (See p.3.)

(3) Connect cables.

(4) Power on.

The AK4112B and AK4394 should be reset once bringing PDN(SW3) “L” upon power-up.

(5) Set up software.

Both the serial and parallel mode are available for AK4112B. AK4394 is fixed to serial control mode. In the serial mode, The IBM-AT compatible PC can control both AK4112B and AK4394 by using the printer port and PORT2 on the AKD4112B. Connect PORT2 (uP-I/F) with PC by 10-line flat cable packed with the AKD4112B.

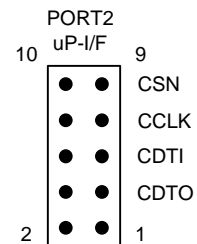

Take care of the direction of connector. There is a mark at pin#1.
The pin layout of PORT2 is as Figure 2.

Figure 2. PORT2 pin layout

■ Connection of PORT2

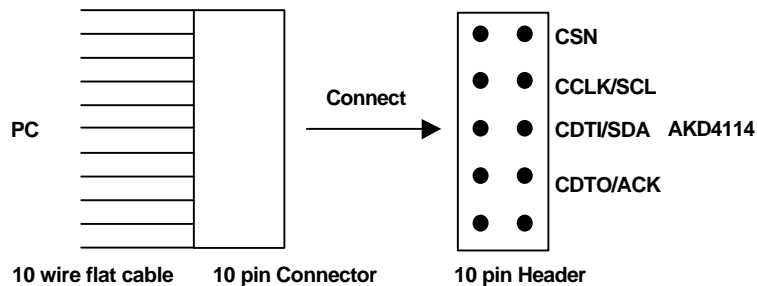

■ Jumper set up. (See the datasheet of AK4112B)

No.	Jumper Name	Function
1	RX0	RX0 input circuit set-up. OPT : Optical (default) BNC : BNC
2	SDA/CDTO	SDA/CDTO pin set-up Serial mode : Short both "SDA" and "CDTO/CM0=L". (default) Parallel mode : Select CM0="H" or CM0="L" to set CM0
3		Don't care
5,6,8	RX4-7	Don't care
4	DIT MCLK	Don't care
7	DIR MCLK ,	MCKO set-up for PORT4(DIR; DAC) MCKO1 : MCKO1 of AK4112B (default) MCKO2 : MCKO2 of AK4112B
9	TX0	Don't care
10	TX1	Don't care
11	BNC	Don't care
12	4112B VD	Power supply source set-up for DVDD of AK4112B. D3V : from Digital 3V Jack (default) A3V : from Analog 3V Jack.
13	REG3V	Power supply source set-up for AVDD of AK4112B. Open : from Analog 3V Jack (default) Short : from the regulator. Do not connect anything the Analog 3V Jack.
14	4395_DVDD	Power supply source set-up for DVDD of AK4394. D5V : from Digital 5V Jack (default) A5V : from Analog 5V Jack
15	REG5V	Power supply source set-up for AVDD of AK4394. Open : from Analog 5V Jack (default) Short : from the regulator. Do not connect anything the Analog 5V Jack.
16	AGND2/DGND	Connection of AGND2(AK4112B AVSS) and DGND(AK4112B DVSS) Open : Separate two grounds. Short : Connect two grounds. (default)
17	AGND2/DGND	Connection of AGND(AK4394 AVSS) and DGND(AK4112B DVSS) Open : Separate two grounds. (default) Short : Connect two grounds.

■ **DIP switch(SW1) set-up : -off- means “L”**

No.	Switch Name	Function
1	IPS0	Don't care
2	DIF0	DIF0 pin set-up (for parallel mode)
3	DIF1	DIF1 pin set-up (for parallel mode)
4	DIF2	DIF2 pin set-up (for parallel mode)
5	IPS1/IIC	Don't care
6	P/SN	P/SN pin set-up. “H”: parallel mode, “L”: serial mode.
7	XTL0	Don't care
8	XTL1	Don't care

■ **DIP switch(SW2) set-up : -off- means “L”**

No.	Switch Name	Function
1	CM1	CM1 pin set-up (for parallel mode)
2	OCKS1	OCKS1 pin set-up (for parallel mode)
3	OCKS0	OCKS0 pin set-up (for parallel mode)
4	TEST1	Don't care
5	-	(reserved)
6	-	(reserved)
7	-	(reserved)
8	-	(reserved)

■ **Toggle switch set-up**

3	PDN	Reset switch for AK4112B and AK4394. Set to “H” during operation. Bring to “L” once after the power is supplied.
---	-----	--

■ **LED indication**

1	INT0	Bright when ERF pin goes to “H”.
2	INT1	Bright when FS96 pin goes to “H”.

■ **Set-up of AK4394 (for the evaluation via DAC. Refer the AK4394 datasheet)**

In case of evaluating via DAC(AK4394), the AK4394 needs to be controlled by serial control. The default set-up of AK4394 audio format is 16bit right justified, but AK4112B is left justified slave mode. Please adjust those two audio formats. In detail, please refer those datasheets.

■ **Set-up of AK4112B (Refer the AK4394 datasheet)**

1. **MCKO1/2 output**

No.	OCKS1	OCKS0	MCKO1	MCKO2	X'tal	fs (kHz)		
0	0	0	256fs	256fs	256fs	32, 44.1, 48, 96	Default	
1	0	1	256fs	128fs	256fs	32, 44.1, 48, 96		
2	1	0	512fs	256fs	512fs	32, 44.1, 48		
3	1	1	Test Mode					

Table 1. Master Clock Frequency Select

2. Clock operation mode

Mode	CM1	CM0	UNLOCK	PLL	X'tal	Clock source	SDTO
0	0	0	-	ON	ON(Note)	PLL	RX
1	0	1	-	OFF	ON	X'tal	DAUX
2	1	0	0	ON	ON	PLL	RX
			1	ON	ON	X'tal	DAUX
3	1	1	-	ON	ON	X'tal	DAUX

Default

ON: Oscillation (Power-up), OFF: STOP (Power-down)

Table 2. Clock Operation Mode select

3. Audio interface format

DIF2	DIF1	DIF0	DAUX	SDTO	LRCK		BICK	
						I/O		I/O
0	0	0	24bit, Left justified	16bit, Right justified	H/L	O	64fs	O
0	0	1	24bit, Left justified	18bit, Right justified	H/L	O	64fs	O
0	1	0	24bit, Left justified	20bit, Right justified	H/L	O	64fs	O
0	1	1	24bit, Left justified	24bit, Right justified	H/L	O	64fs	O
1	0	0	24bit, Left justified	24bit, Left justified	H/L	O	64fs	O
1	0	1	24bit, I ² S	24bit, I ² S	L/H	O	64fs	O
1	1	0	24bit, Left justified	24bit, Left justified	H/L	I	64-128fs	I
1	1	1	24bit, I ² S	24bit, I ² S	L/H	I	64-128fs	I

Default

Table3. Audio Data Format

AKD4112B Control Program operation manual

■ Set-up of evaluation board and control software

1. Set up the AKD4112B according to previous term.
2. Connect IBM-AT compatible PC with AKD4112B by 10-line type flat cable (packed with AKD4112B). Take care of the direction of 10pin header. (Please install the driver in the floppy-disk when this control software is used on Windows 2000/XP. Please refer “Installation Manual of Control Software Driver by AKM device control software”. In case of Windows95/98/ME, this installation is not needed. This control software does not operate on Windows NT.)
3. Insert the CD-ROM labeled “AK4112B Evaluation Kit” into the CD-ROM drive.
4. Access the CD-ROM drive and double-click the icon of “akd4112B” to set up the control program.
5. Then please evaluate according to the follows.

■ Operation flow

Keep the following flow.

1. Set up the control program according to explanation above.
2. Click “Port Setup” button.
3. Then set up the dialog and input data.

■ Explanation of each buttons

1. [Port Setup] : set up the printer port.
2. [Write default] : initialize the register of AK4112B.
3. [All read] : read all registers.
4. [Read] : read data from each register.
5. [Write] : write data to each register.

If you want to write the input data to AK4112B, click “OK” button. If not, click “Cancel” button.

■ Indication of data

Input data is indicated on the register map. Red letter indicates “H” or “1” and blue one indicates “L” or “0”. Blank is the part that is not defined in the datasheet.

End.

AK4394 Control Program ver 1.0 operation manual

1. Connect IBM-AT compatible PC with AKD4112B by 10-line type flat cable (packed with AKD4112B). Take care of the direction of 10pin header. (Please install the driver in the floppy-disk when this control software is used on Windows 2000/XP. Please refer "Installation Manual of Control Software Driver by AKM device control software". In case of Windows95/98/ME, this installation is not needed. This control software does not operate on Windows NT.)
2. Insert the CD-ROM labeled "AK4112B Evaluation Kit" into the CD-ROM drive.
3. Access the CD-ROM drive and double-click the icon of "ak4394.exe" to set up the control program.
4. Then follow the displayed comment (See the following).

```
===== <<Operating flow>> =====
Display register map → Write data / Reset etc. → loop
=====
```

At first the following default data and register map are displayed:

```
***** AK4394 Control Program ver 2.0 , '02/12 *****
Copyright(c) 2002, Asahi Kasei Microsystems co.,ltd.
All rights reserved.

-----
ADDR = 00 : 01 <Control 1> ( 0      CKS2  CKS1  CKS0  DIF2  DIF1  DIF0  RSTN )
ADDR = 01 : 00 <Control 2> ( DZFE  DZFM  SLOW  DFS1  DFS0  DEM1  DEM0  SMUTE )
ADDR = 02 : 00 <TEST>      ( GA1   GA0   TEST5  TEST4  TEST3  TEST2  TEST1  TEST0 )

Input 1(Write), R(Reset) or S(Stop) :
```

- 1) If you input "1", you can write data to AK4394.
The following message is displayed:

```
You can write data to AK4394
Input Register Address(2 figure, hex)(00-02) =
```

Input register address in 2 figures of hexadecimal. (Significant figure can be omitted if it is "0".)

Then current data of this address is displayed:

```
ADDR = 00 : 01 <Control 1> ( 0      CKS2  CKS1  CKS0  DIF2  DIF1  DIF0  RSTN )
                        0      0      0      0      0      0      0      1
Input Register Data   (2 figure, hex)(00-FF) =
```

Input control data in 2 figures of hexadecimal.

Then the data written to this address is displayed.

```
ADDR = 00 : 01 <Control 1> ( 0      CKS2  CKS1  CKS0  DIF2  DIF1  DIF0  RSTN )
                        0      0      0      1      0      1      0      1
```

- 2) If you input "R" or "r", this program writes default data to all register addresses.
- 3) If you input "S" or "s", this program is terminated.

End.

IMPORTANT NOTICE

- These products and their specifications are subject to change without notice. Before considering any use or application, consult the Asahi Kasei Microsystems Co., Ltd. (AKM) sales office or authorized distributor concerning their current status.
- AKM assumes no liability for infringement of any patent, intellectual property, or other right in the application or use of any information contained herein.
- Any export of these products, or devices or systems containing them, may require an export license or other official approval under the law and regulations of the country of export pertaining to customs and tariffs, currency exchange, or strategic materials.
- AKM products are neither intended nor authorized for use as critical components in any safety, life support, or other hazard related device or system, and AKM assumes no responsibility relating to any such use, except with the express written consent of the Representative Director of AKM. As used here:
 - (a) A hazard related device or system is one designed or intended for life support or maintenance of safety or for applications in medicine, aerospace, nuclear energy, or other fields, in which its failure to function or perform may reasonably be expected to result in loss of life or in significant injury or damage to person or property.
 - (b) A critical component is one whose failure to function or perform may reasonably be expected to result, whether directly or indirectly, in the loss of the safety or effectiveness of the device or system containing it, and which must therefore meet very high standards of performance and reliability.
- It is the responsibility of the buyer or distributor of an AKM product who distributes, disposes of, or otherwise places the product with a third party to notify that party in advance of the above content and conditions, and the buyer or distributor agrees to assume any and all responsibility and liability for and hold AKM harmless from any and all claims arising from the use of said product in the absence of such notification.

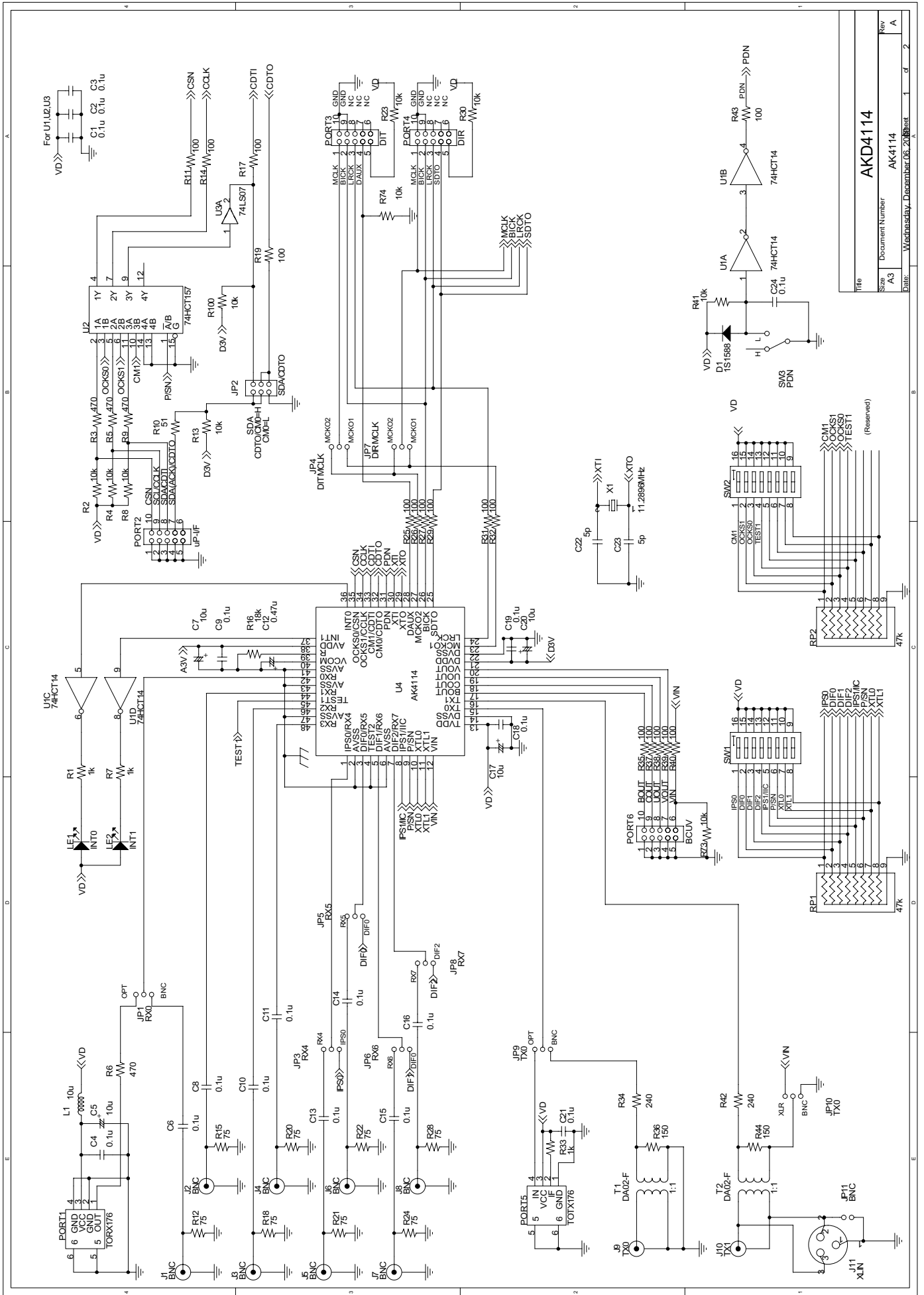

Title	AKD4114		
Size	A3	Document Number	AK4114
Date	Wednesday, December 06, 2006	Rev	A

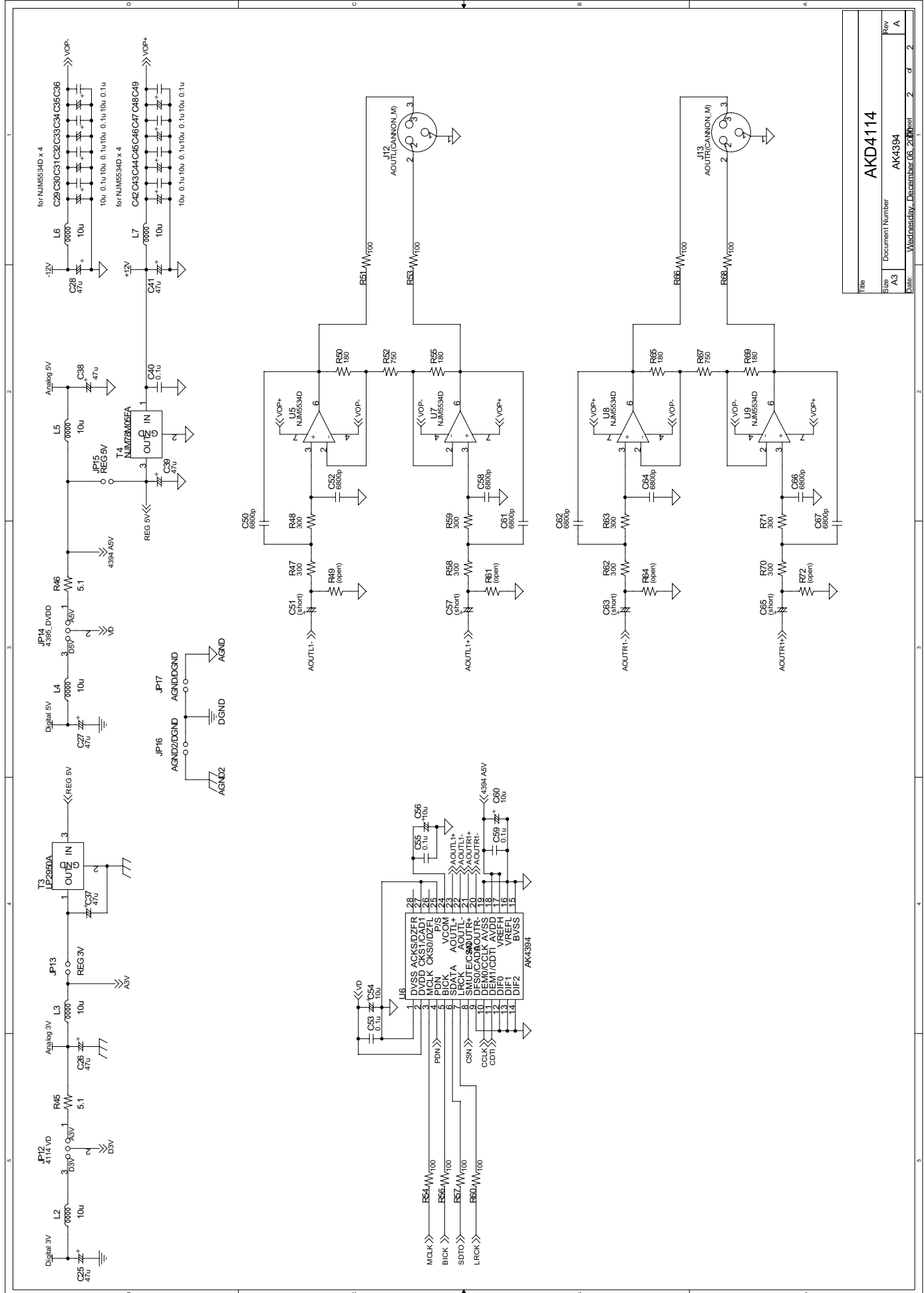

Title		AKD4114	
Size	Document Number	AK4394	
Rev	Date	Wednesday, December 06, 2006	2 of 2

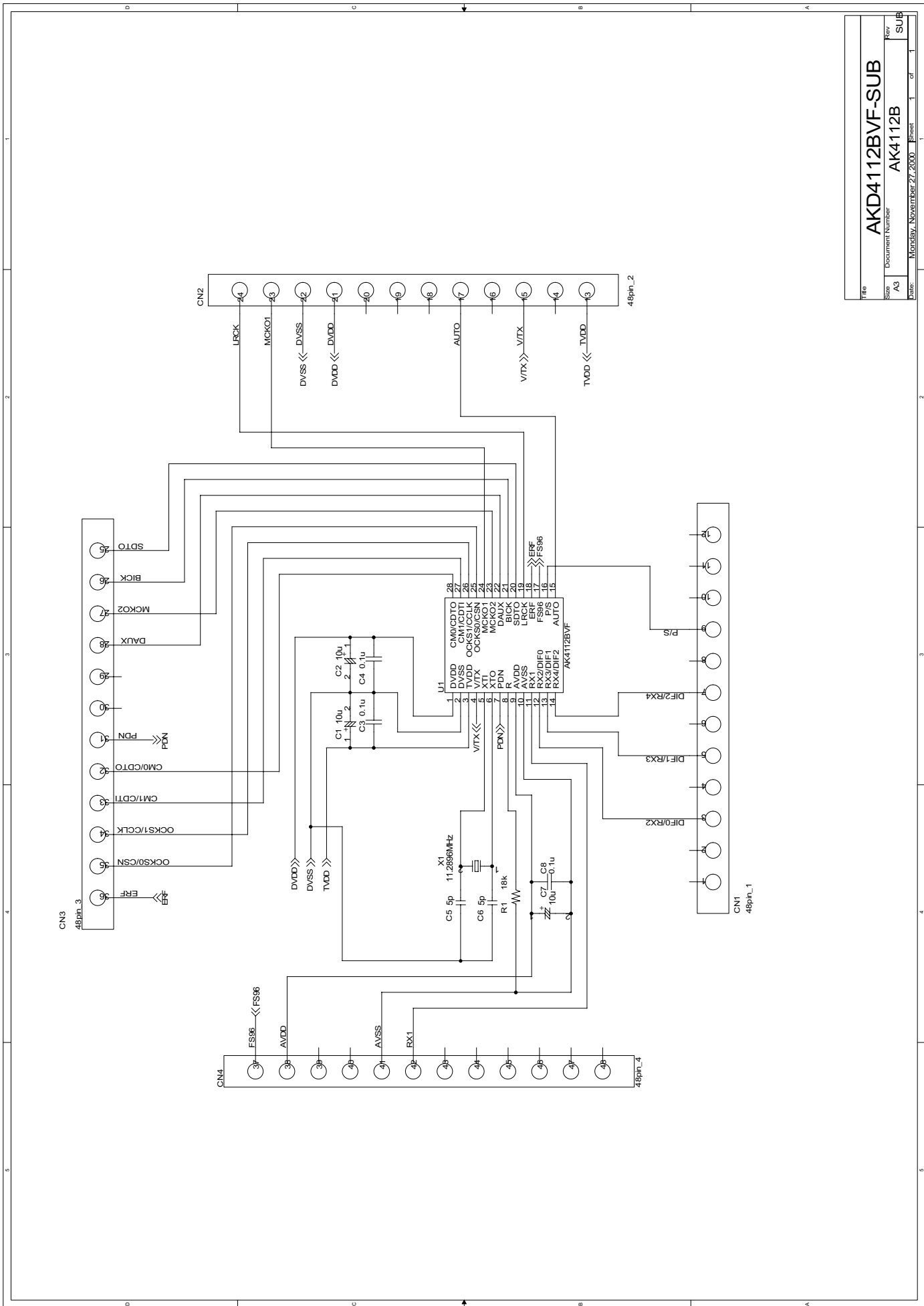

Title		AKD4112BVF-SUB	
Size	Document Number	AK4112B	
AC	Rev	SUB	
Print	Monday, November 27, 2000	Sheet	of

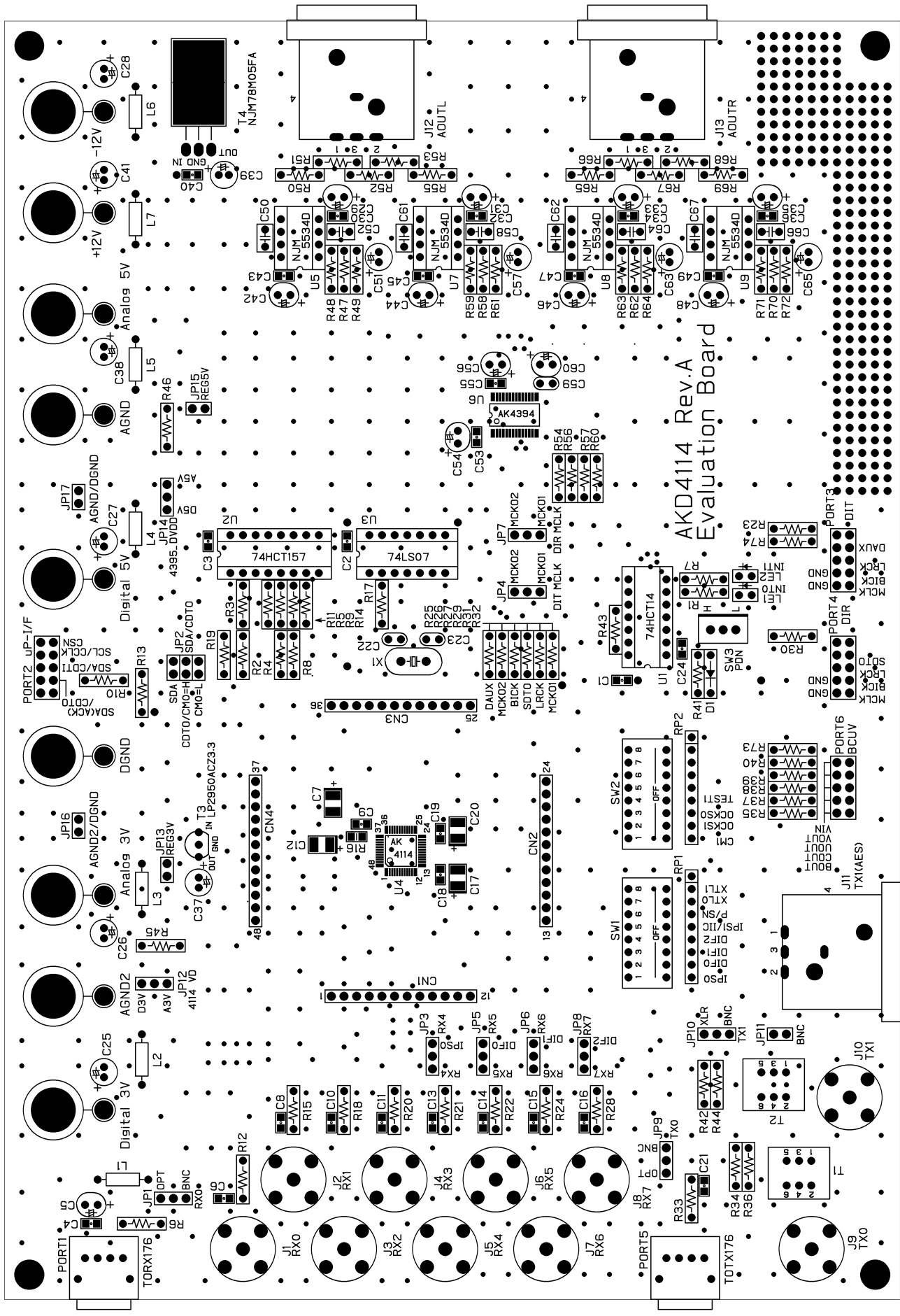

AKD4114 Rev.A
Evaluation Board

AKD4114 Rev.A L1 SR SILK

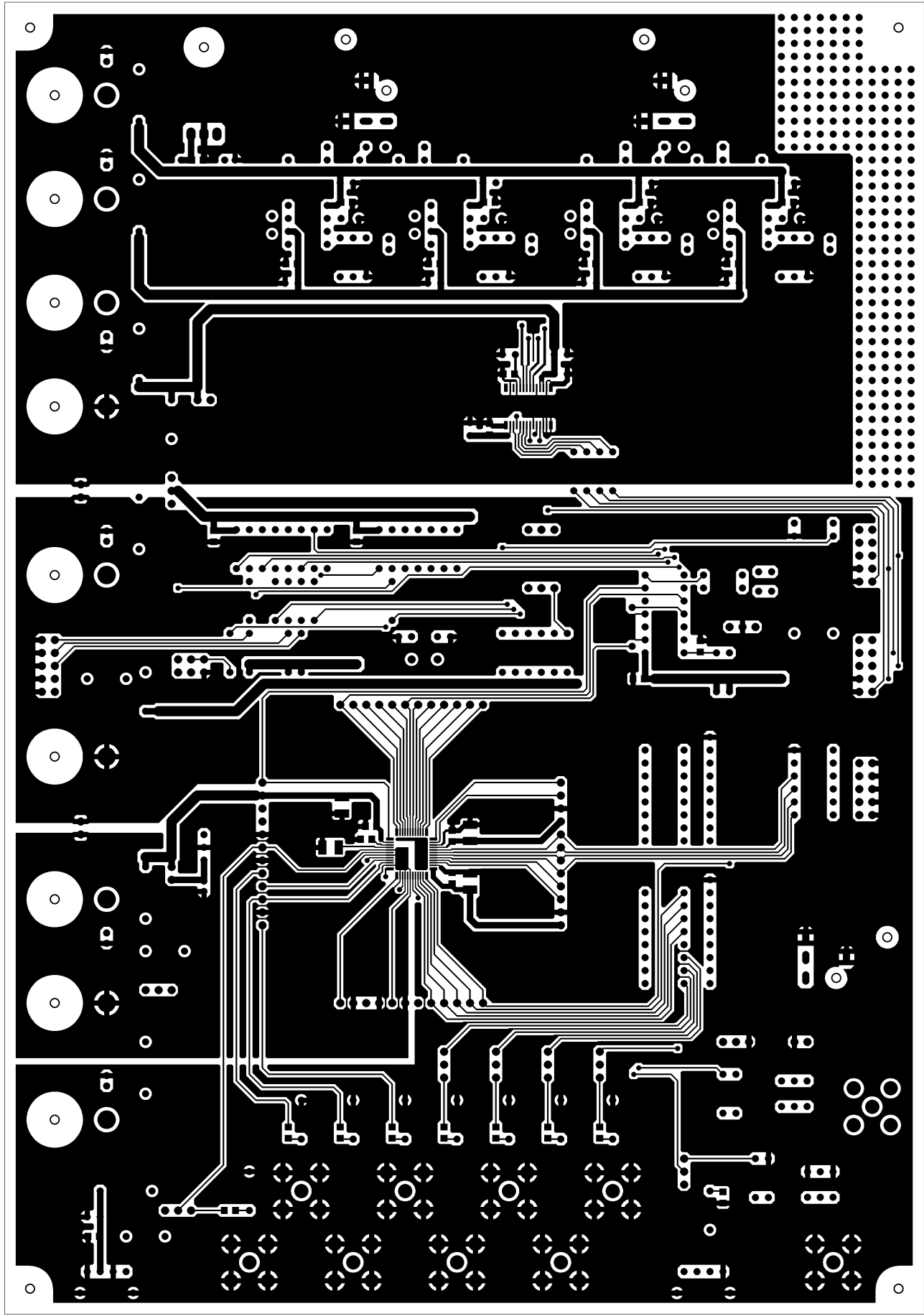

AKD4114 Rev.A L1

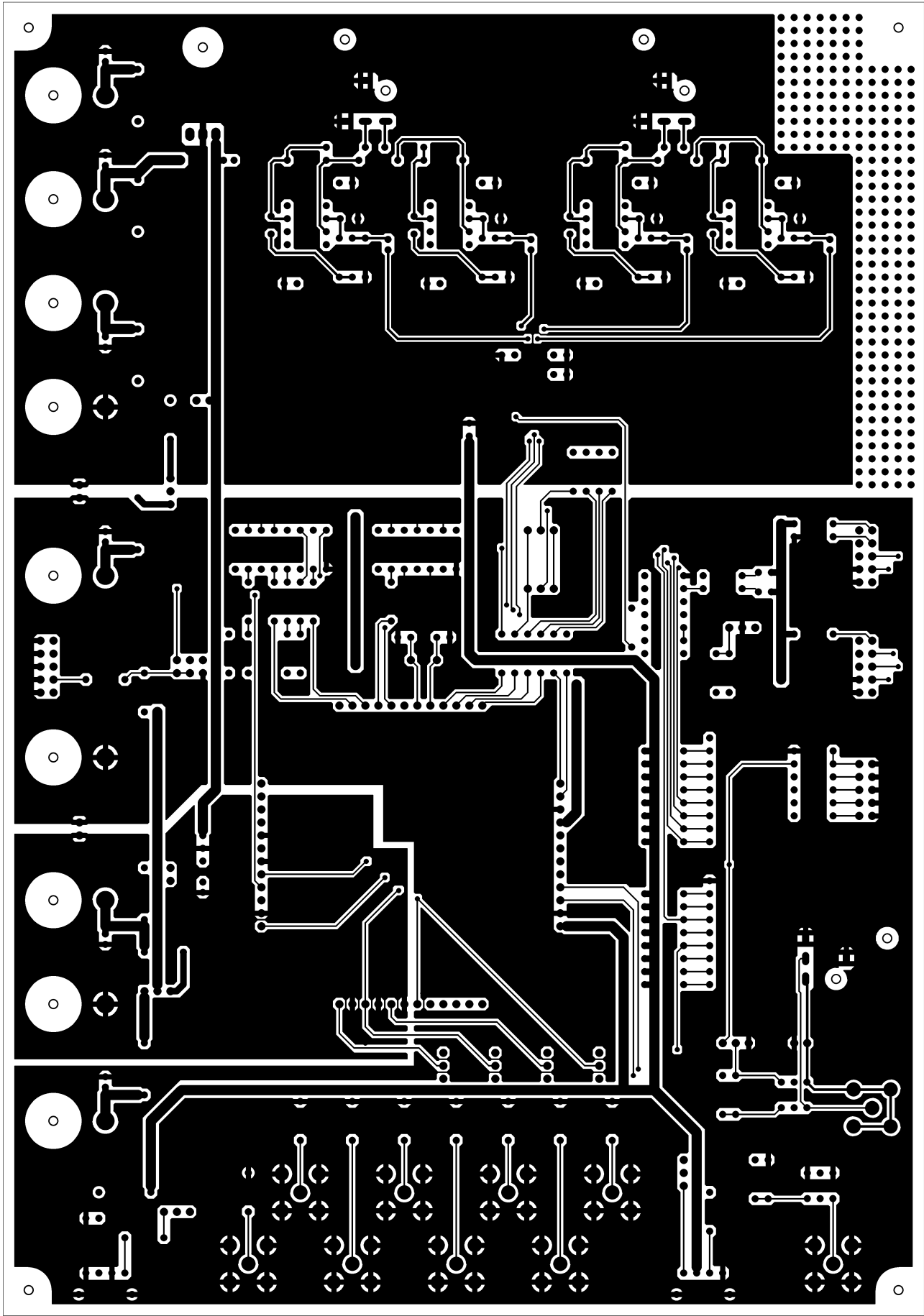

AKD4114 Rev.A LS

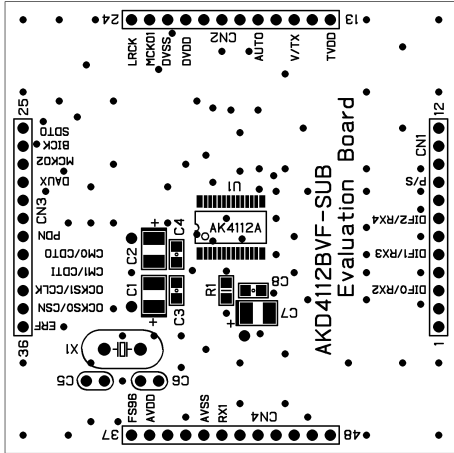

AKD4112BVF SUB Rev.A L1 SR SILK

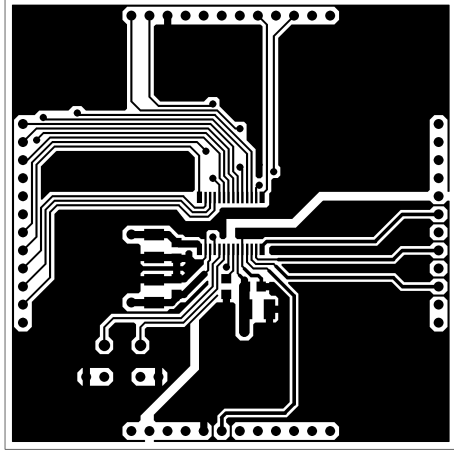

AKD4112BVF SUB Rev.A L1

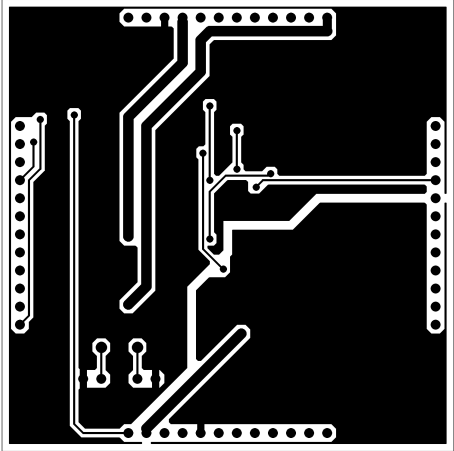

VKD411SBAE 2NB Rev.V TS