



# AKD4527B

## Evaluation board Rev.D for AK4527B

GENERAL DESCRIPTION

The AKD4527B is an evaluation board for the AK4527B, the Multi-channel Audio CODEC. The AKD4527B also has the digital audio interface and can achieve the interface with digital audio systems via opt-connector or BNC connector.

**■ Ordering guide**

AKD4527B --- Evaluation board for AK4527B  
 (Cable for connecting with printer port of IBM-AT compatible PC and control software are packed with this.)

FUNCTION

- On-board analog input buffer circuit
- Compatible with 2 types of interface
  - DIT(AK4353)/DIR(AK4112A) with optical output/input and BNC input
  - Direct interface with AC3 decoder by 10pin header
- 10pin header for serial control interface

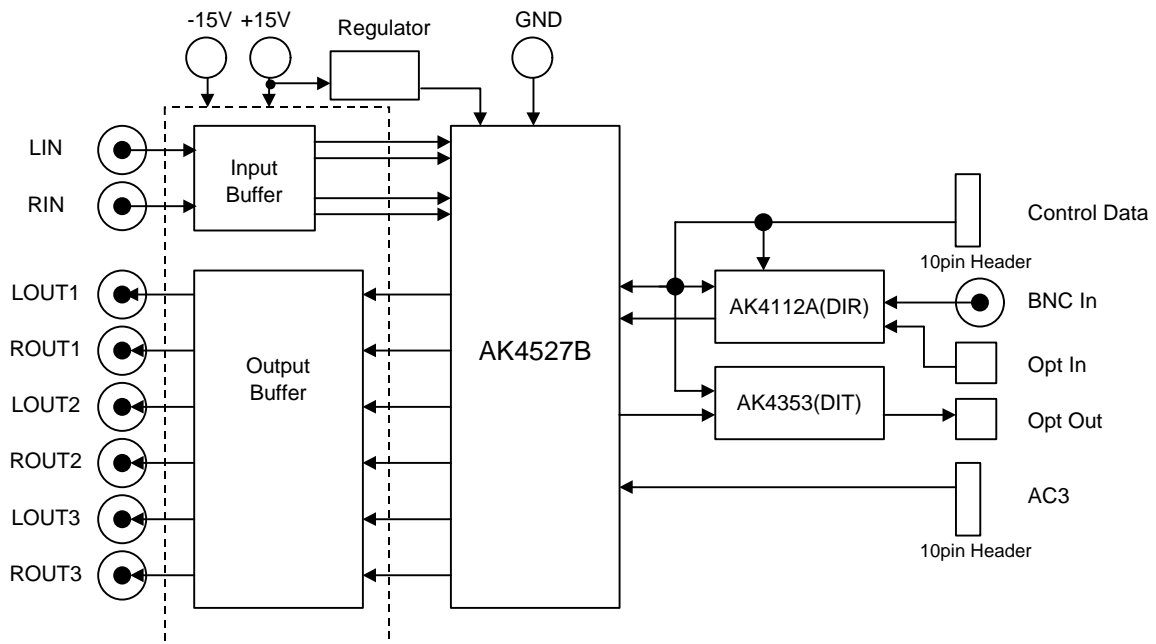
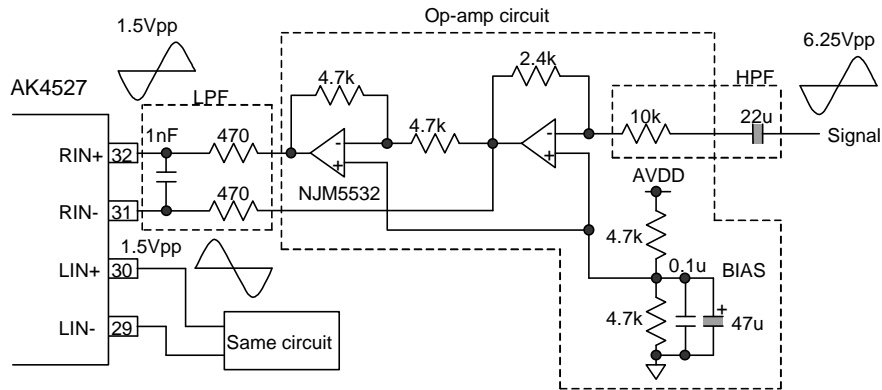

Fig 1. AKD4527B Rev.D Block Diagram

\*Circuit diagram and PCB layout are attached at the end of this manual.

■ Consideration for analog input circuit



1) Frequency response of HPF

The HPF is implemented on board to cancel the DC offset of analog output of AK4527B.

Frequency response of 1st-order HPF

$$|Amplitude|^2 = 1 / \{1 + (fc/f)^2\}; fc = 1 / 2\pi RC = 0.7\text{Hz} @ R=10\text{k}, C=22\mu$$

fin	20Hz
Frequency Response	-0.006dB

2) Gain and S/N of op-amp circuit

Two stages of inverting op-amp circuit are implemented on board to convert single-ended input to full-differential input for ADC of AK4527B.

a) Gain

The gain of each op-amp circuit is as following table:

	Gain[dB]
First step	-12.40
Second step	0.00

Therefore input level for this board is

$$-5.51\text{dBV} (= 1.5\text{Vpp}) + 12.40\text{dB} = +6.89\text{dBV} = 6.25\text{Vpp} = 2.21\text{Vrms}$$

b) S/N (Theory:  $BW=20k+A$ )

The output noise level of each op-amp circuit is as following table:

	Noise[dBV]
First step	-120.56
Second step	-115.91

The noise level summing differential output of op-amp circuit is

$$-113.64\text{dBV} = -114.13\text{dB} (0\text{dB} = +0.49\text{dBV} = 3\text{Vpp})$$

S/N of ADC is

$$104.5\text{dB} \text{ (measurement)}$$

Therefore total S/N of op-amp circuit and ADC is

$$104.05\text{dB} \text{ (measurement: } 103.9\text{dB)}$$

3) Frequency response of LPF

1st-order RC LPF is implemented on board to attenuate the noise around the internal sampling frequency of ADC (64fs=3.072MHz@fs=48kHz)

Frequency response of 1st-order LPF

| Amplitude |<sup>2</sup> = 1/{1+(f/fc)<sup>2</sup>}; fc=1/2πRC=**169.3kHz**@R=470,C=2000p  
(1nF capacitance prior to ADC is doubled because of full-differential input.)

fin	20kHz	40kHz
Frequency Response	<b>-0.060dB</b>	<b>-0.236dB</b>

■ Consideration for analog output circuit

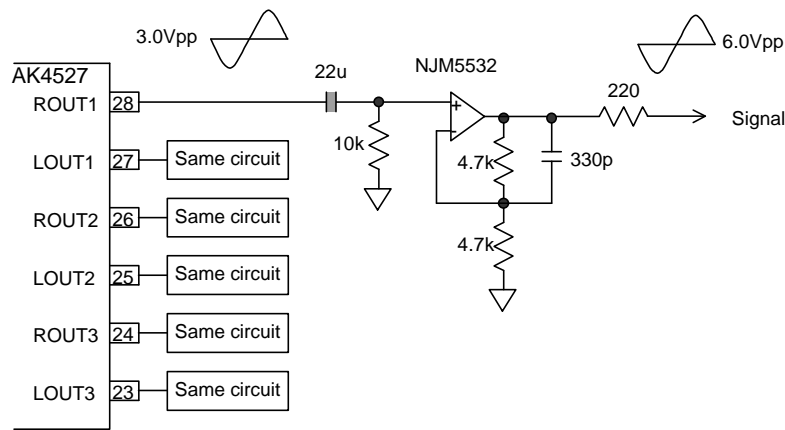

1) Frequency response of HPF

The HPF is implemented on board to cancel the DC offset of analog output of AK4527B.

Frequency response of 1st-order HPF

| Amplitude |<sup>2</sup> = 1/{1+(fc/f)<sup>2</sup>}; fc=1/2πRC=**0.7Hz**@R=10k,C=22u

fin	20Hz
Frequency Response	<b>-0.006dB</b>

2) Gain, S/N and frequency response of op-amp circuit

1st-order filter with non-inverting amp is implemented on board to double the analog output level and attenuate out-of-band noise.

a) Gain

The gain is

$$1+4.7k/4.7k = +6.00dB.$$

Therefore the output level of this board is

$$0.51dBV(=3.0Vpp) + 6.00dB = \mathbf{6.51dBV = 6.0Vpp = 2.12Vrms.}$$

b) S/N (Theory: BW=20k+A)

The output noise level of non-inverting amp

$$-110.36dBV = -116.87dB \text{ (0dB=6.51dBV)}$$

S/N of DAC is

$$106.0dB \text{ (measurement)}$$

Therefore total S/N of op-amp circuit and DAC is

$$\mathbf{105.66dB} \text{ (measurement: 105.5dB).}$$

c) Frequency response of filter

Frequency response of the 1st-order filter

$$| \text{Amplitude} |^2 = K * \{ 1 + (f/fc_2)^2 \} / \{ 1 + (f/fc_1)^2 \};$$

$$K = 1 + 4.7k / 4.7k = 2,$$

$$fc_1 = 1 / 2\pi RC = 102.7kHz @ R=4.7k, C=330p,$$

$$fc_2 = K * fc_1 = 205.3kHz$$

Frequency response referenced to output level of this board is as following table:

f <sub>in</sub>	DC	20kHz	40kHz	80kHz	145kHz	∞
Frequency Response	0dB	<b>-0.121dB</b>	<b>-0.452dB</b>	<b>-1.448dB</b>	-3dB	-6dB

If the frequency response of filter influences the system, 1st-order LPF is also available as the following figure:

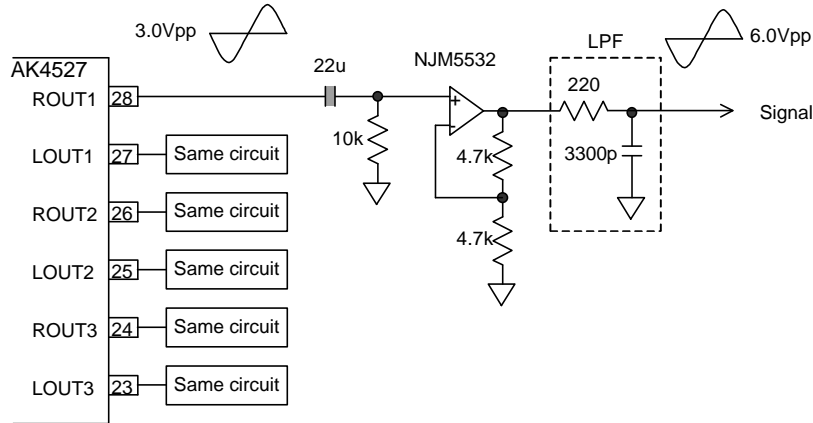

Frequency response of this LPF

$$| \text{Amplitude} |^2 = 1 / \{ 1 + (f/fc)^2 \};$$

$$fc = 1 / 2\pi RC = 219kHz @ R=220, C=3300p$$

Frequency response referenced to output level of this board is as following table:

f <sub>in</sub>	DC	20kHz	40kHz	80kHz	219kHz	∞
Frequency Response	0dB	<b>-0.036dB</b>	<b>-0.142dB</b>	<b>-0.543dB</b>	-3dB	-∞dB

The total frequency response of this board is sum of the external filter and internal LPF of AK4527B.

These filters are effective to attenuate the high frequency noise since some measurement units is sensitive for out-of-band noise.

■ Operation sequence

(1) Set up the power supply lines.

[+12V] (orange jack) = +12 ~ +15V

[-12V] (blue jack) = -12 ~ -15V

[AGND] (black jack) = 0V

[DGND] (black jack) = 0V

Each supply line should be distributed from the power supply unit.

±12V are supplied to analog interface.

+12V is regulated to +5V and +3.3V by regulators(T1,T2).

+5V is supplied to digital interface, AK4527B and TVDD of AK4112A.

+3.3V is supplied to AVDD and DVDD of AK4112A.

(2) Set up the evaluation mode and jumper pins. (See p.3.)

(3) Connect Optical or BNC connector.

[PORT2] (OPT\_IN) : Optical input to RX1 of AK4112A

[J10] (RX2) : BNC input to RX1 of AK4112A

(4) Power on.

The AK4527B, AK4112A and AK4353 should be reset once bringing PDN(SW1) “L” upon power-up.

(5) Adjust the interface format

Serial control is needed after the reset by SW1. The default value for interface format of AK4527B, AK4112A, and AK4353 is “Right justified, 20 bit”, “Left justified, 24 bit”, and “I<sup>2</sup>S”, respectively. The software “4527.exe” packed with the AKD4527B is used for the set-up of the AK4527B.

Evaluation mode 1 : DIF1-0 bit of the AK4527B should be set to “11” .

Evaluation mode 2, 3: DIF1-0 bit of the AK4527B should be set to “10”.

Evaluation mode 4 : AK4112A and AK4527B should be set to adjust the format of DSP.

(6) Set up software.

The control mode of AK4527B and AK4112A is fixed to “serial”.

The AKD4527B can be controlled via the printer port (parallel port) of IBM-AT compatible PC. Connect PORT3(uP-I/F) with PC by 10-line flat cable packed with the AKD4527B.

Take care of the direction of connector. There is a mark at pin#1.

The pin layout of PORT3 is as Figure 2.

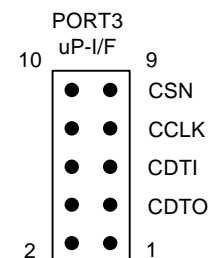

Figure 2. PORT3 pin layout

## ■ Evaluation mode

### 1) Evaluation of ADC

TOTX176 is used for digital output. Clock mode of the AK4112A should be set to PLL mode or X'tal mode.

### 2) Evaluation of DAC

TORX176 or BNC is used for digital input. Clock mode of the AK4112A should be set to PLL mode. "4112" should be selected on JP4,5 and 6.

### 3) Loopback mode

Clock mode of the AK4112A should be set to PLL mode or X'tal mode. "4112" should be selected on JP4,5 and 6.

### 4) Evaluation of DAC using DSP

"DSP" should be selected on JP4,5 and 6.

Evaluation mode	AK4112A clock set-up	JP4,5,6	Used I/F
ADC	CM1="0", CM0="0"(PLL mode) or CM1="0", CM0="1"(X'tal mode)	Don't care	TOTX176 optical output
DAC	CM1="0", CM0="0"(PLL mode)	"4112"	
Loopback	CM1="0", CM0="1"(X'tal mode)	"4112"	
Using DSP	CM1="0", CM0="0"(PLL mode)	"DSP"	PORT5(10-pin Header)

Table 2.Evaluation mode

## ■ Jumper pin set up

[JP1] (GND) ---Analog GND and Digital GND

[JP4,5,6] (SDTI1,2,3) --- AK4527B SDTI1,2,3 input source select

<DSP> : Serial Data is input from DSP via PORT5.

<4112> : Serial Data is input from AK4112A SDTO. <default>

[JP2] (V/TX) --- AK4112A V/TX output select.

<V> : Validity. <default>

<TX> : Transmit channel (through data)

## ■ The function of the toggle SW.

[SW1] : Resets the AK4527B, AK4112A and AK4353. Keep "H" during normal operation.

## ■ The indication content for LED.

[LE1] (ERF) : AK4112A unlock and parity error output.

[LE2] (FS96) : AK4112A 96kHz sampling detect.

[LE3] (AUTO) : AK4112A AC-3/MPEG detect.

[LE4] (V) : Validity

<b>MEASUREMENT RESULTS</b>
----------------------------

## 1) ADC part

## [Measurement condition]

- Measurement unit: Audio Precision, System two, Cascade
- MCLK : 256fs
- BICK : 64fs
- fs : 44.1kHz
- BW : 10Hz~20kHz(fs=44.1kHz), 10Hz~48kHz(fs=96kHz)
- Bit : 24bit
- Power Supply : AVDD=DVDD=TVDD=5V
- Analog Input : Differential
- Interface : DIT
- Temperature : Room

fs=44.1kHz

Parameter	Input signal	Measurement filter	Results
S/(N+D)	1kHz, -0.5dB	20kLPF	96.2dB
DR	1kHz, -60dB	20kLPF, A-weighted	103.3dB
S/N	no signal	20kLPF, A-weighted	103.9dB

fs=96kHz

Parameter	Input signal	Measurement filter	Results
S/(N+D)	1kHz, -0.5dB	fs/2	86.7dB
DR	1kHz, -60dB	fs/2, A-weighted	102.9dB
S/N	no signal	fs/2, A-weighted	103.4dB

## 2) DAC part

## [Measurement condition]

- Measurement unit: Audio Precision, System two, Cascade
- MCLK : 256fs
- BICK : 64fs
- fs : 44.1kHz, 96kHz
- BW : 10Hz~22kHz (fs=44.1kHz), 10Hz~40kHz (fs=96kHz)
- Bit : 24bit
- Power Supply : AVDD=DVDD=TVDD=5V
- Analog Input : Differential
- Interface : DIR
- Temperature : Room

fs=44.1kHz

Parameter	Input signal	Measurement filter	Results
S/(N+D)	1kHz, 0dB	20kLPF	97.3dB
DR	1kHz, -60dB	22kLPF, A-weighted	105.1dB
S/N	“0”data	22kLPF, A-weighted	105.5dB

fs=96kHz

Parameter	Input signal	Measurement filter	Results
S/(N+D)	1kHz, 0dB	40kLPF	96.2dB
DR	1kHz, -60dB	40kLPF	100.5dB
		22kLPF, A-weighted	104.9dB
S/N	“0”data	40kLPF	100.6dB
		22kLPF, A-weighted	104.9dB



1.ADC

AKM

(ADC fs=44.1kHz)  
AK4527 FFT (Input Level=-0.5dBFS, fin=1kHz)

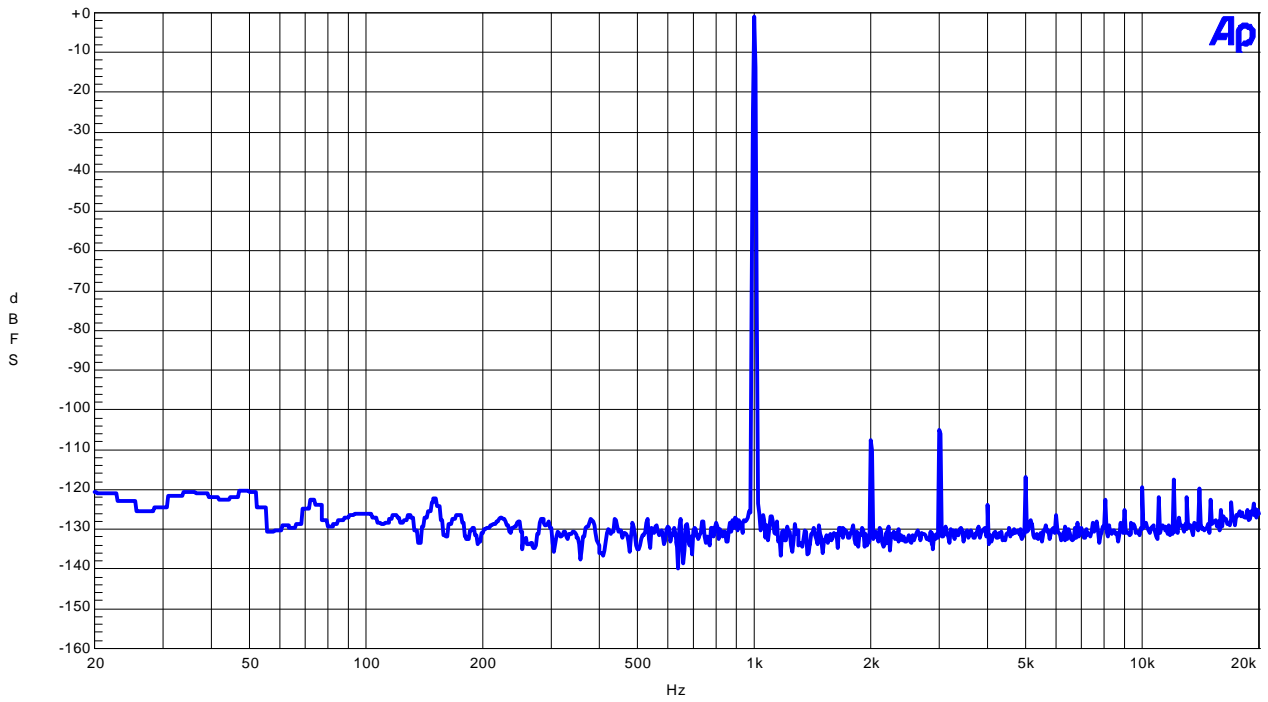

FFT (Input=-0.5dBFS, fin=1kHz)

AKM

AK4527 FFT (Level=-60dBFS, fin=1kHz)

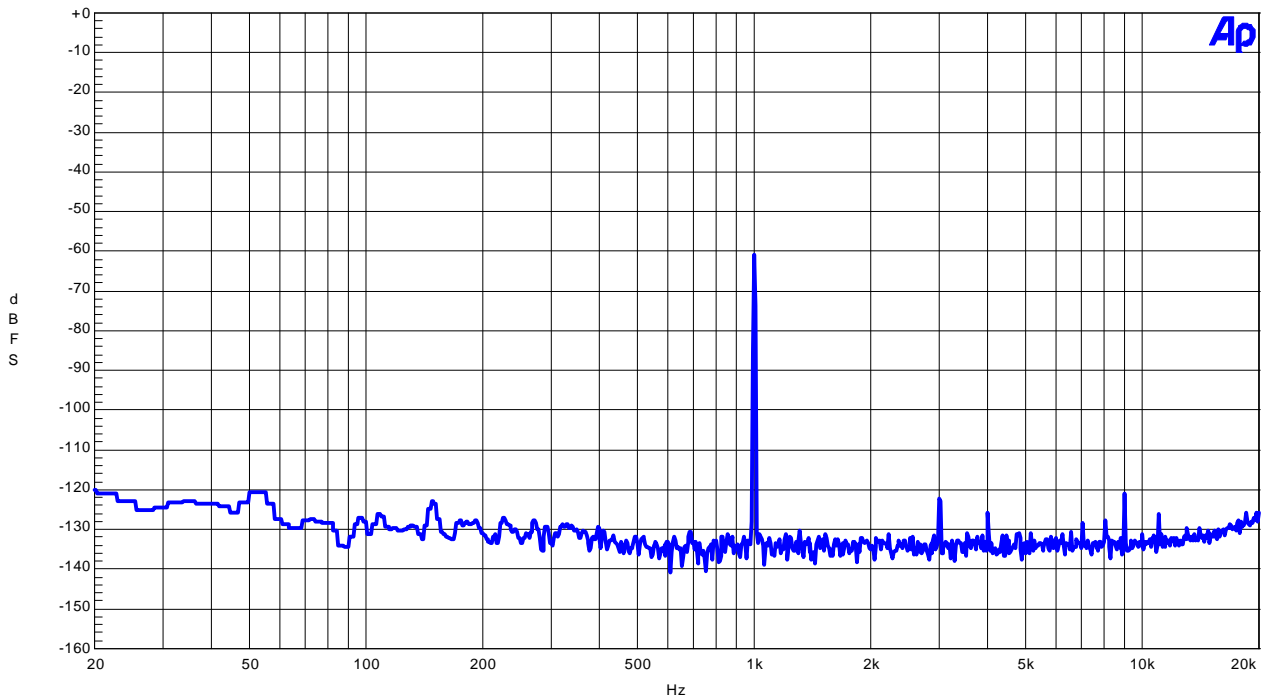

FFT (Input=-60dBFS, fin=1kHz)

AKM

(ADC fs=44.1kHz)  
AK4527 FFT(noise floor)

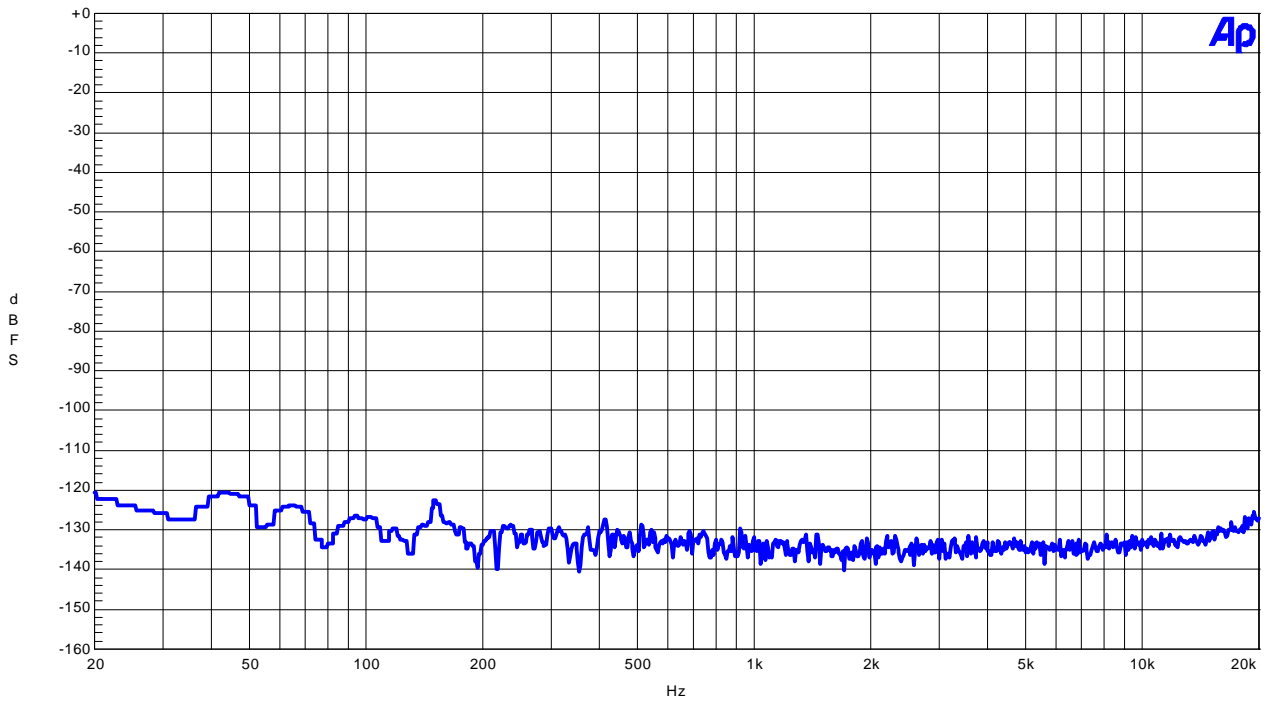

FFT (noise floor)

(ADC fs=44.1kHz)

AKM

AK4527 THD + N vs Amplitude(fin=1kHz)

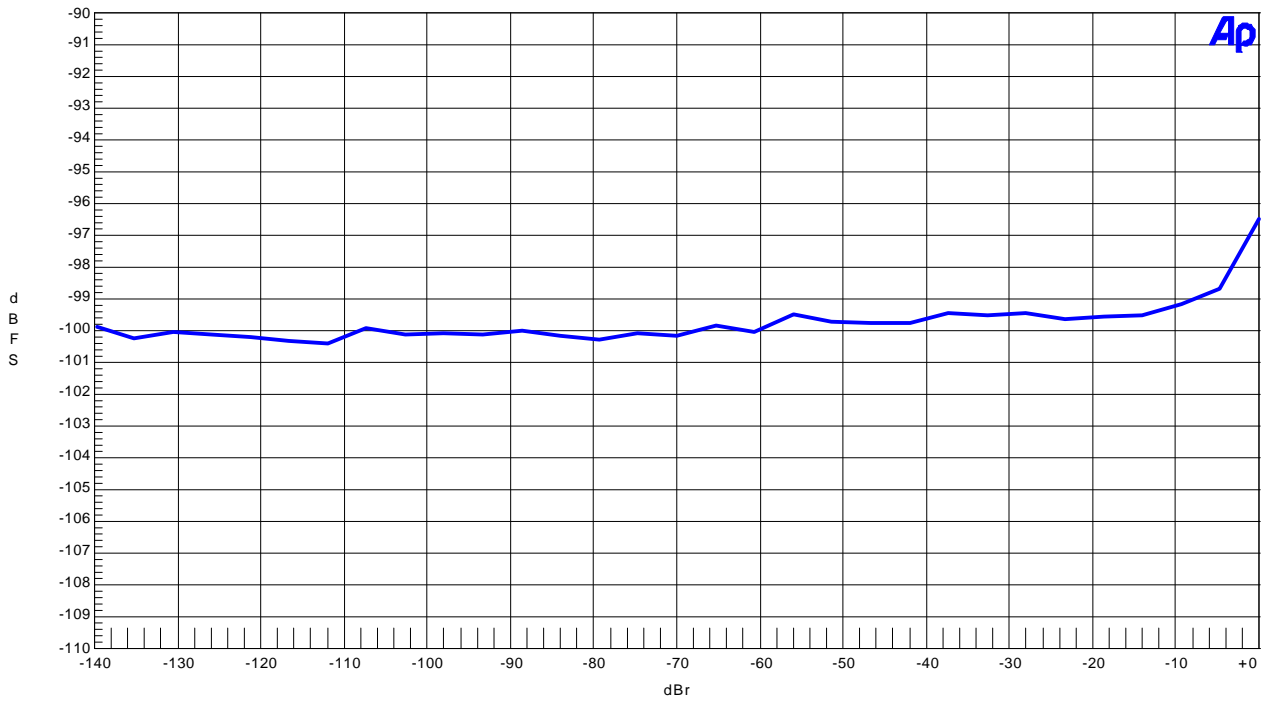

THD + N vs Amplitude (fin=1kHz)

AKM

AK4527 THD + N vs Input Frequency(Input Level=-0.5dBFS)

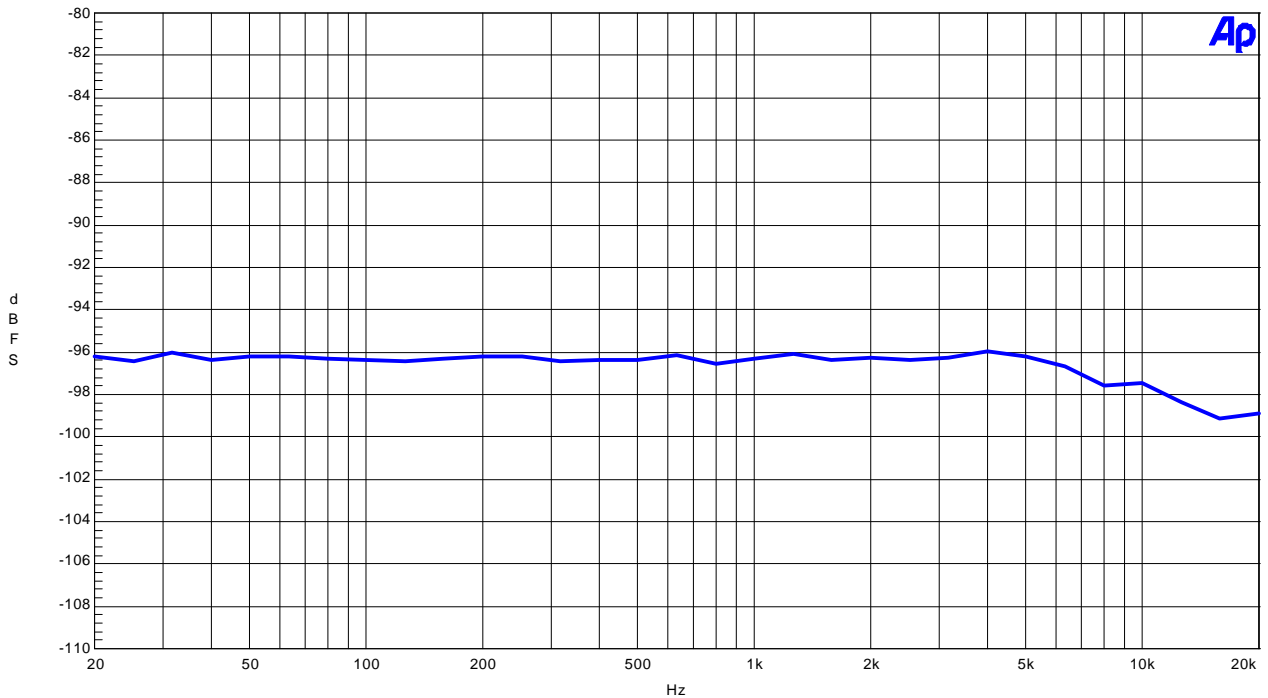

THD + N vs Input Frequency (Input=-0.5dBFS)

AKM (ADC fs=44.1kHz)  
AK4527 Linearity

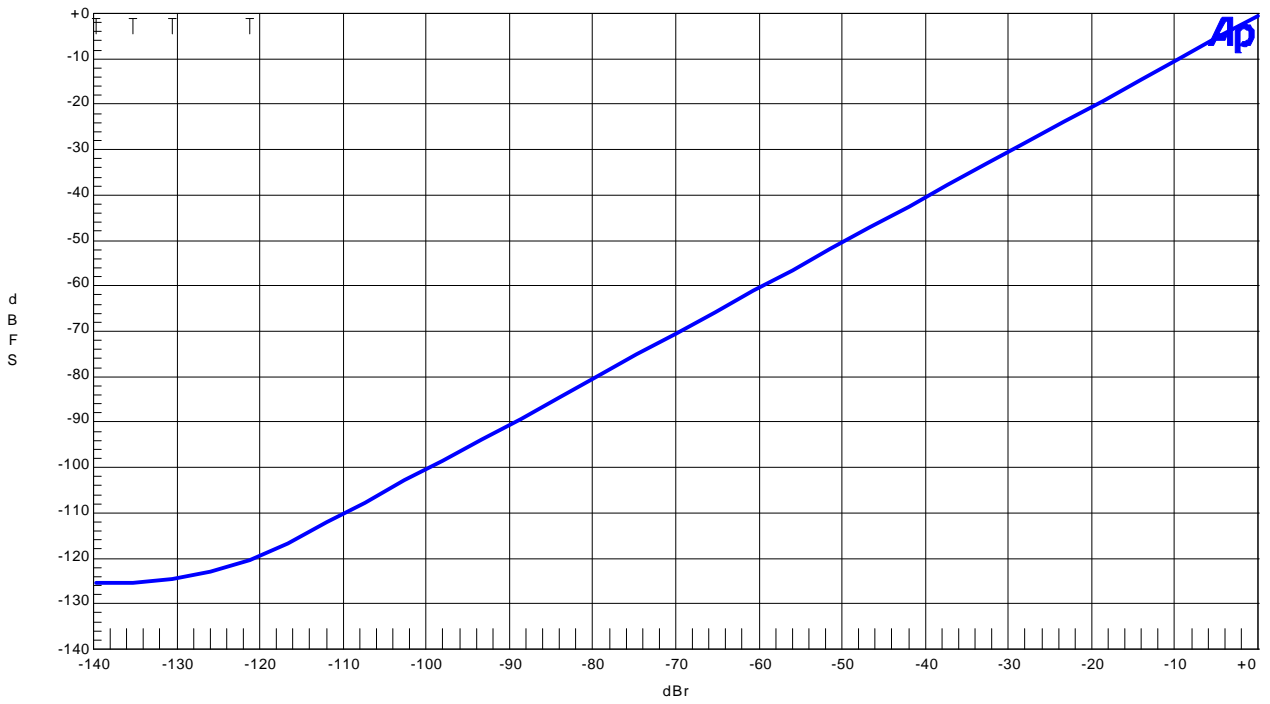

Linearity(fin=1kHz)

AKM AK4527 Linearity

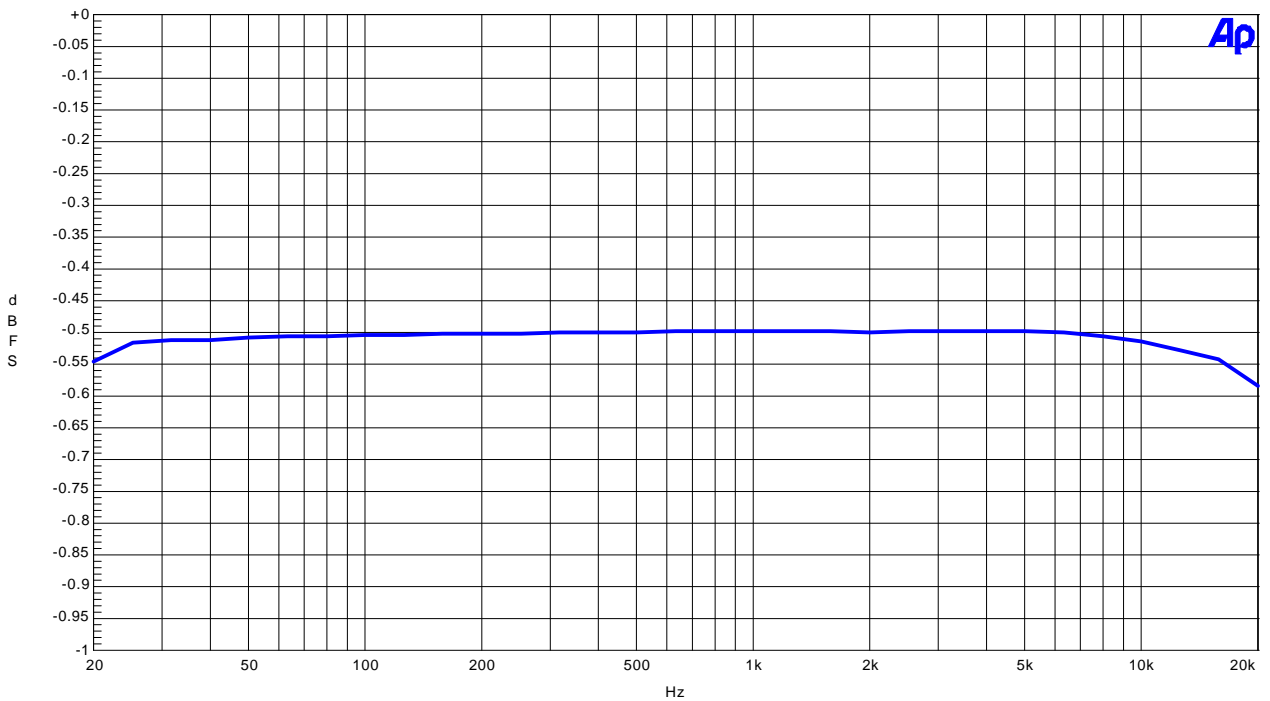

Frequency Response(Input Level=-0.5dBFS)  
(including input RC filter)

AKM

(ADC fs=44.1kHz)  
AK4527 Crosstalk

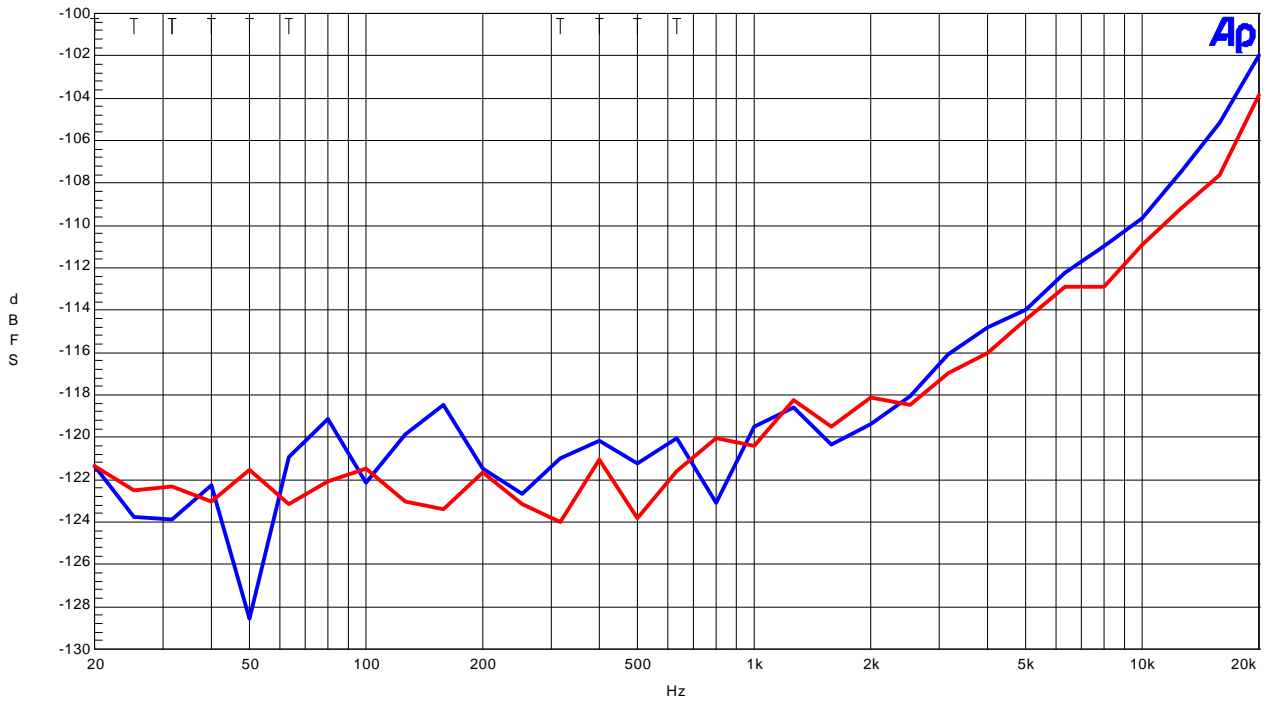

Crosstalk (Upper = Rch, Lower = Lch)

AKM

(ADC fs=96kHz)  
AK4527 FFT (Input Level=-0.5dBFS, fin=1kHz)

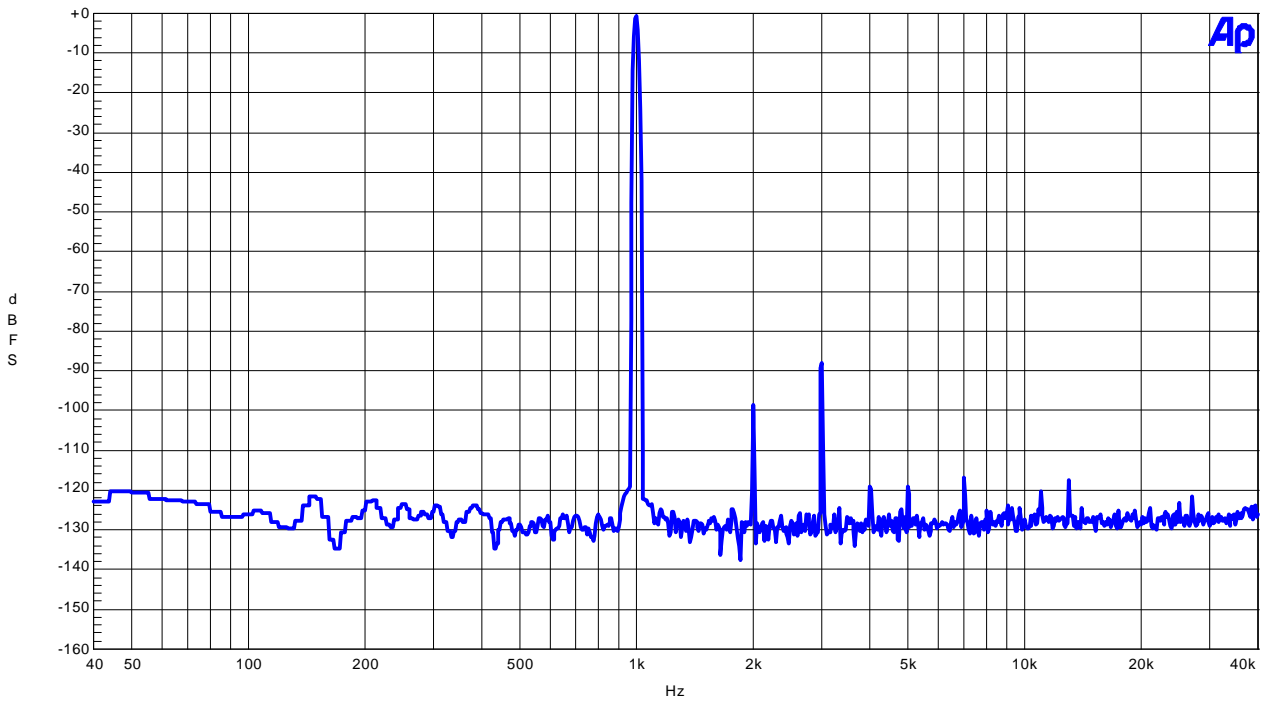

FFT(Input=-0.5dBFS, fin=1kHz)

AKM

AK4527 FFT (Input Level=-60dBFS, fin=1kHz)

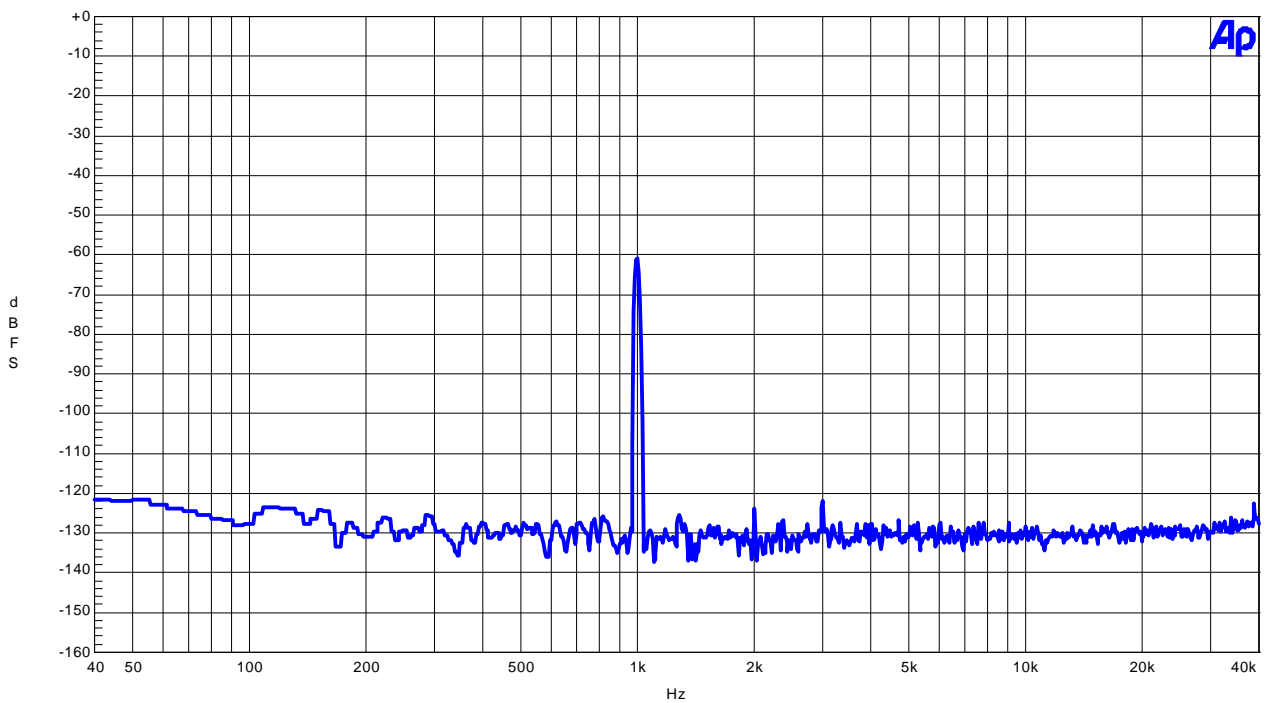

FFT(Input=-60dBFS, fin=1kHz)

AKM

(ADC fs=96kHz)  
AK4527 FFT (noise floor)

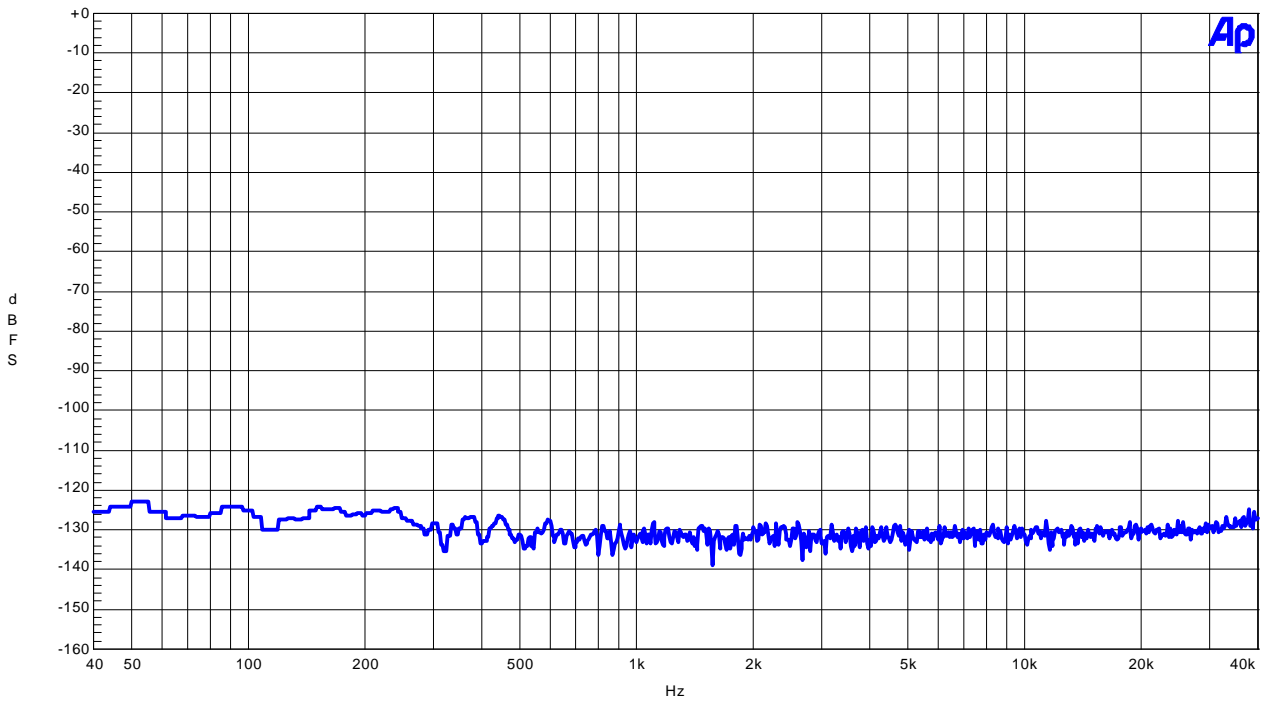

FFT(Input = noise floor)

AKM

AK4527 THD + N vs Amplitude(fin=1kHz)

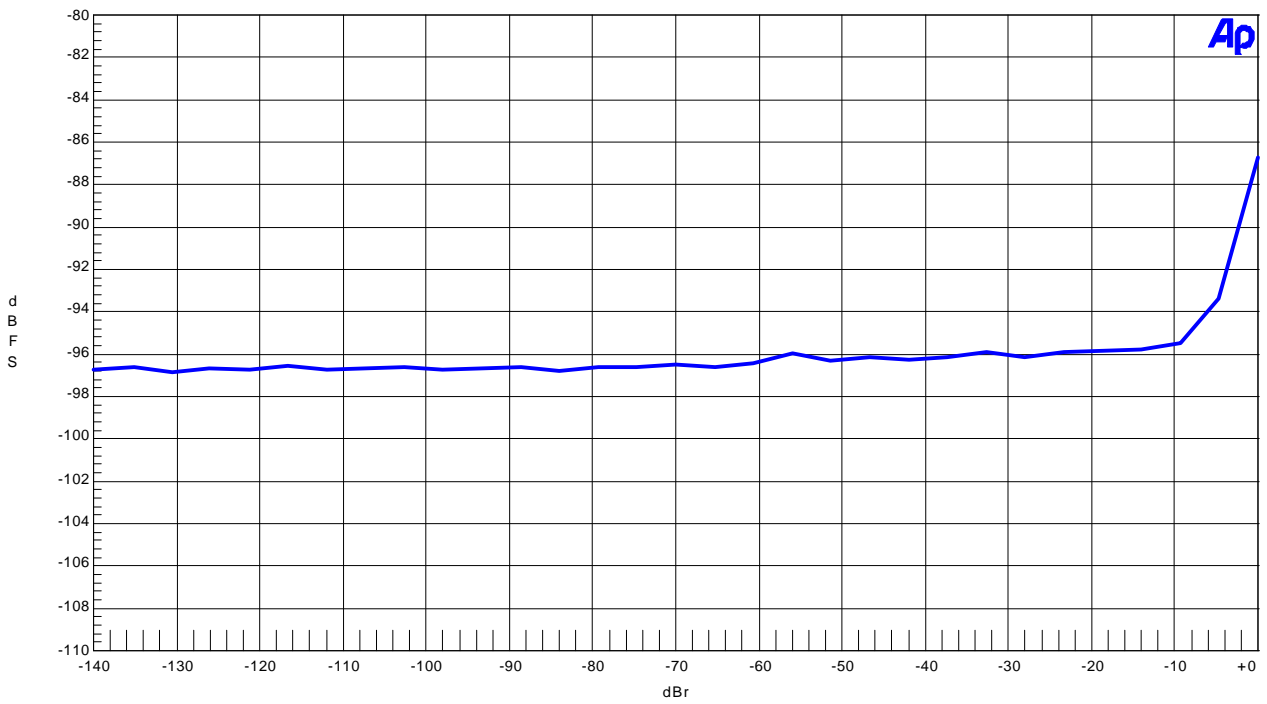

AKM

THD + N vs Amplitude(fin=1kHz)  
AK4527 THD + N vs Input Frequency(Input Level=-0.5dBFS)

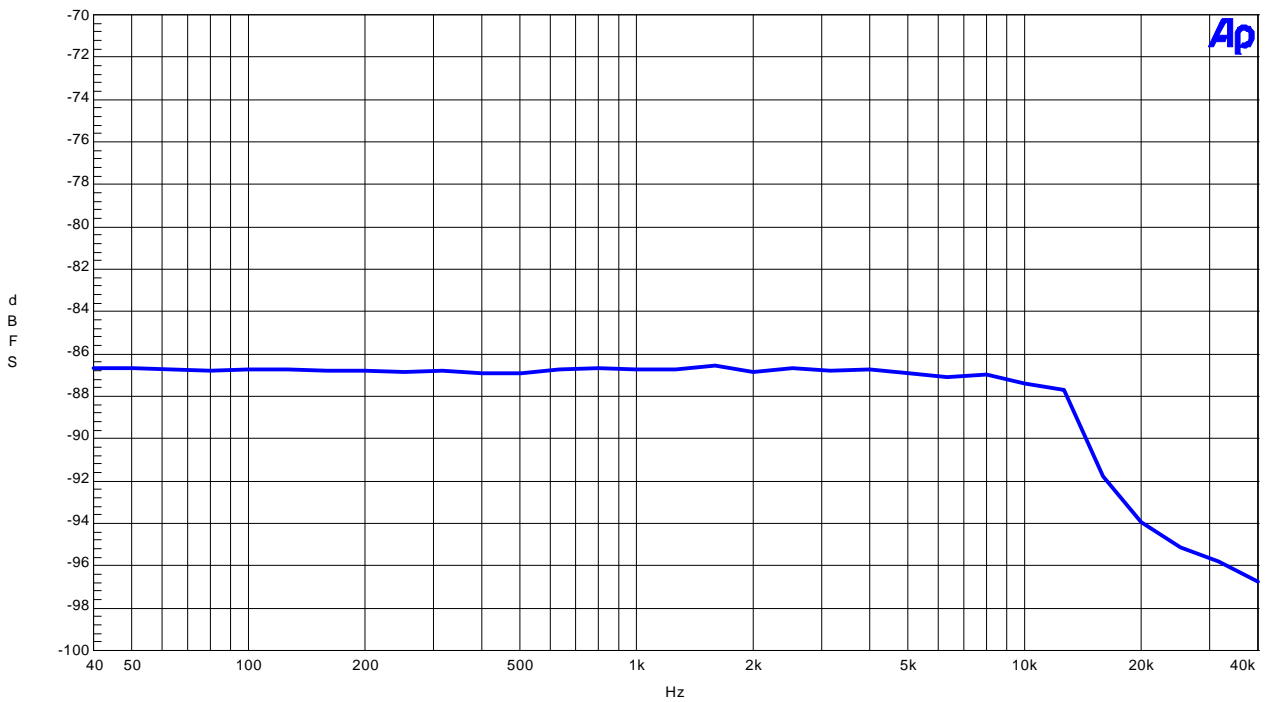

THd + N vs Input Frequency(Input Level=-0.5dBFS)



AKM

AK4527 Linearity

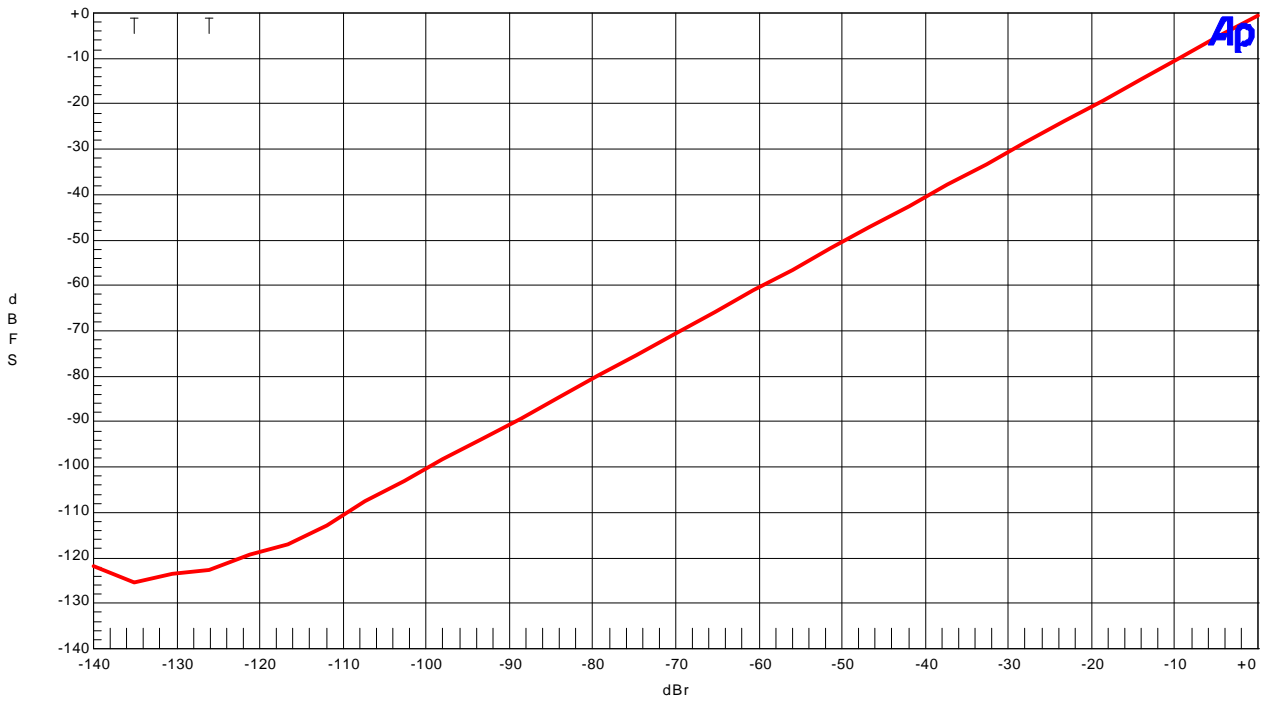

AKM

Linearity(fin=1kHz)  
AK4527 Crosstalk

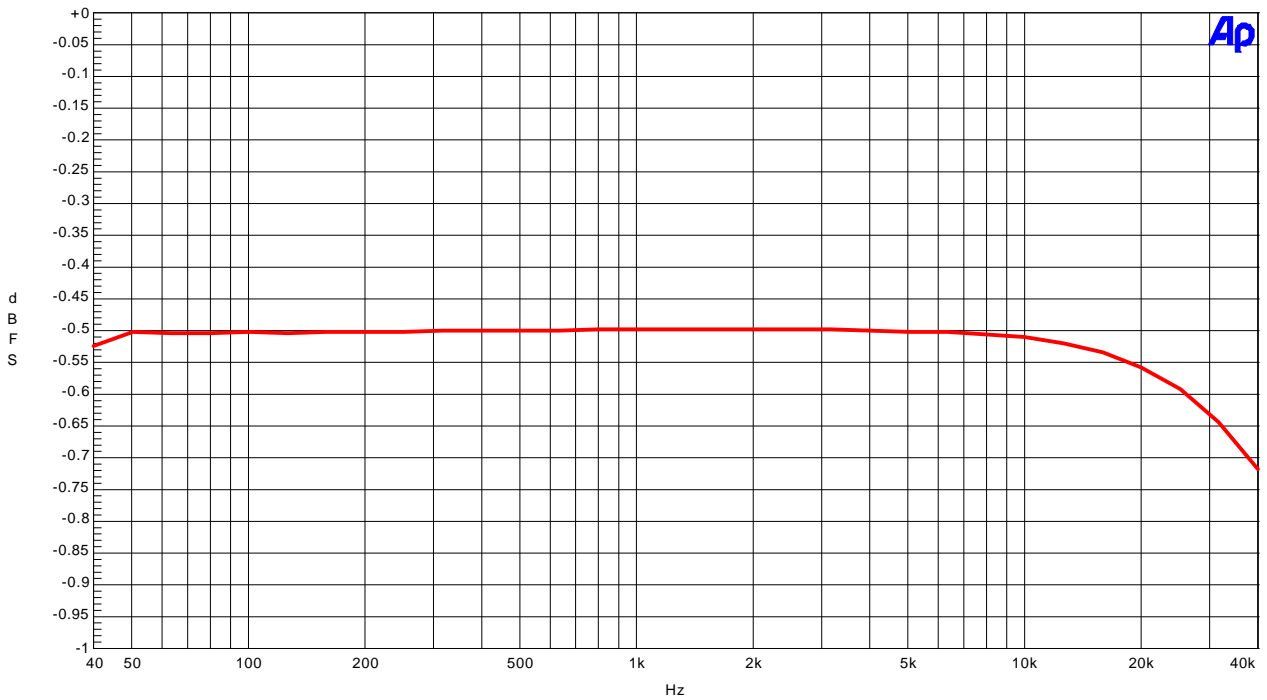

Frequency Response(Input Level=-0.5dBFS)  
(including input RC filter)

AKM

AK4527 Crosstalk

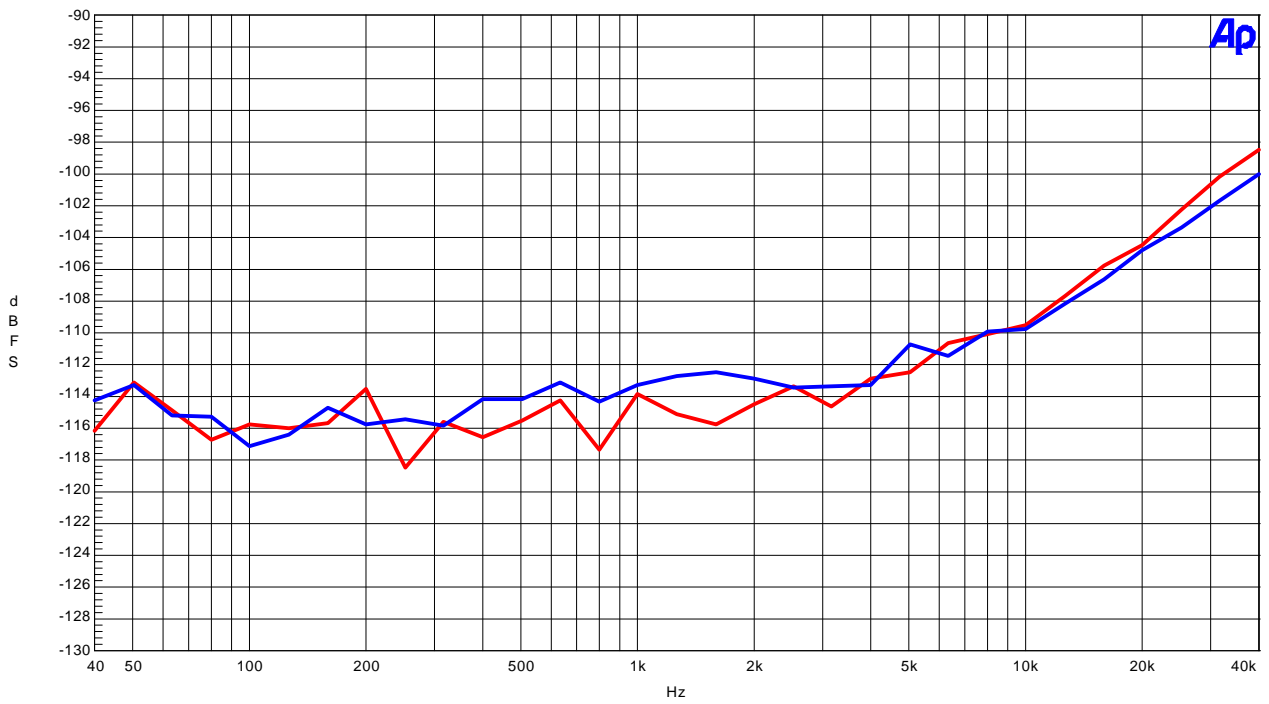

Crosstalk (Upper = Rch, Lower = Lch)

2.DAC

AKM

(DAC fs=44.1kHz)  
AK4527 DAC FFT (Input Level=0dBFS, fin=1kHz)

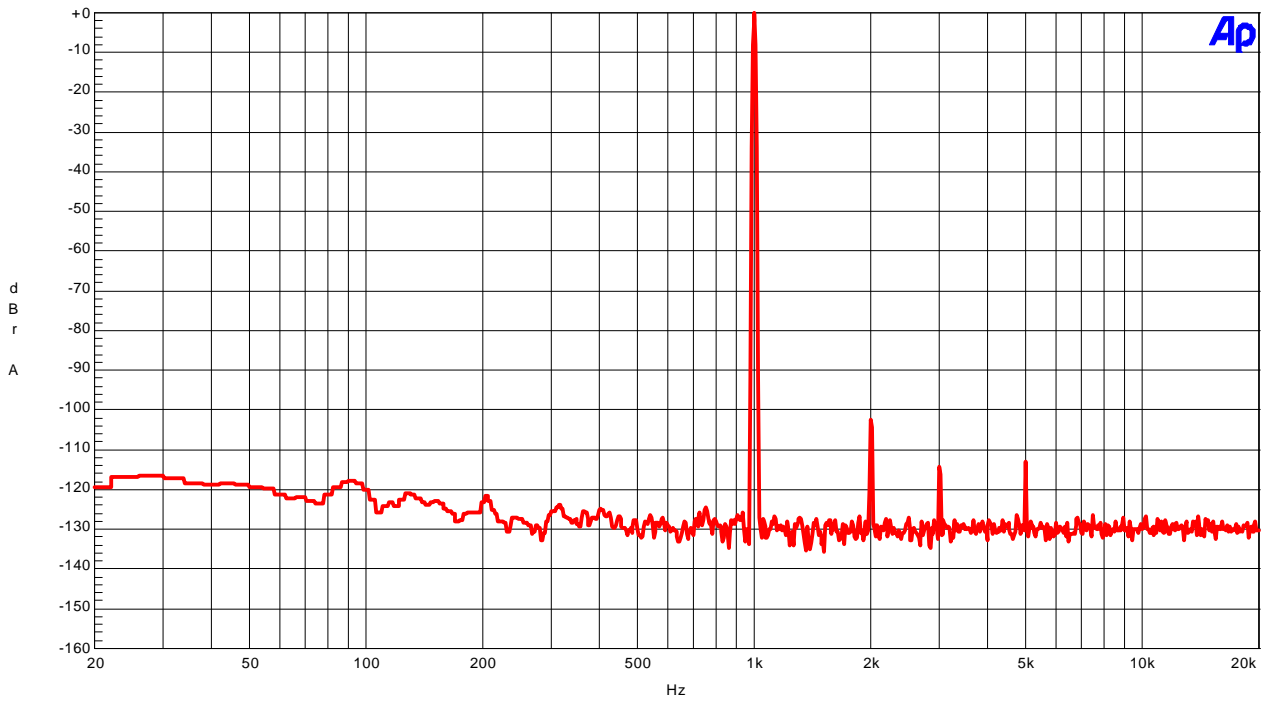

FFT (Input=0dBFS, fin=1kHz)

AKM

AK4527 DAC FFT (Input Level=-60dBFS, fin=1kHz)

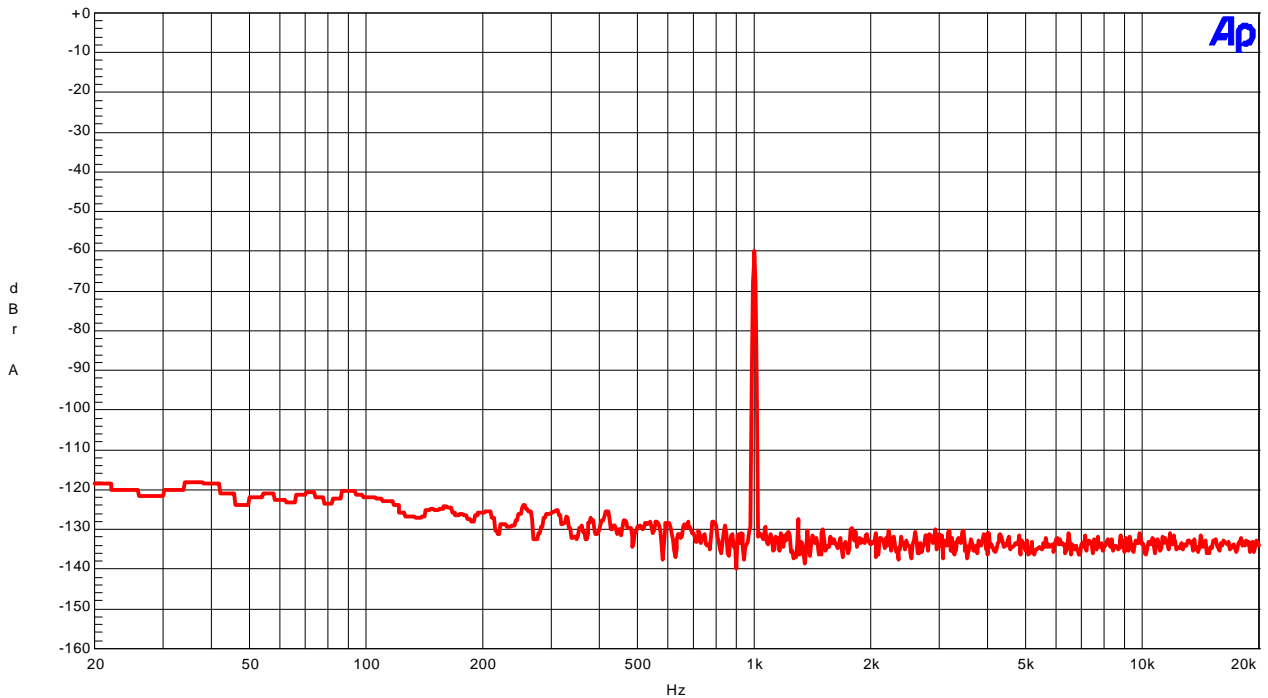

FFT (Input=-60dBFS, fin=1kHz)

(DAC fs=44.1kHz)

AKM

AK4527 DAC FFT (Input 0data)

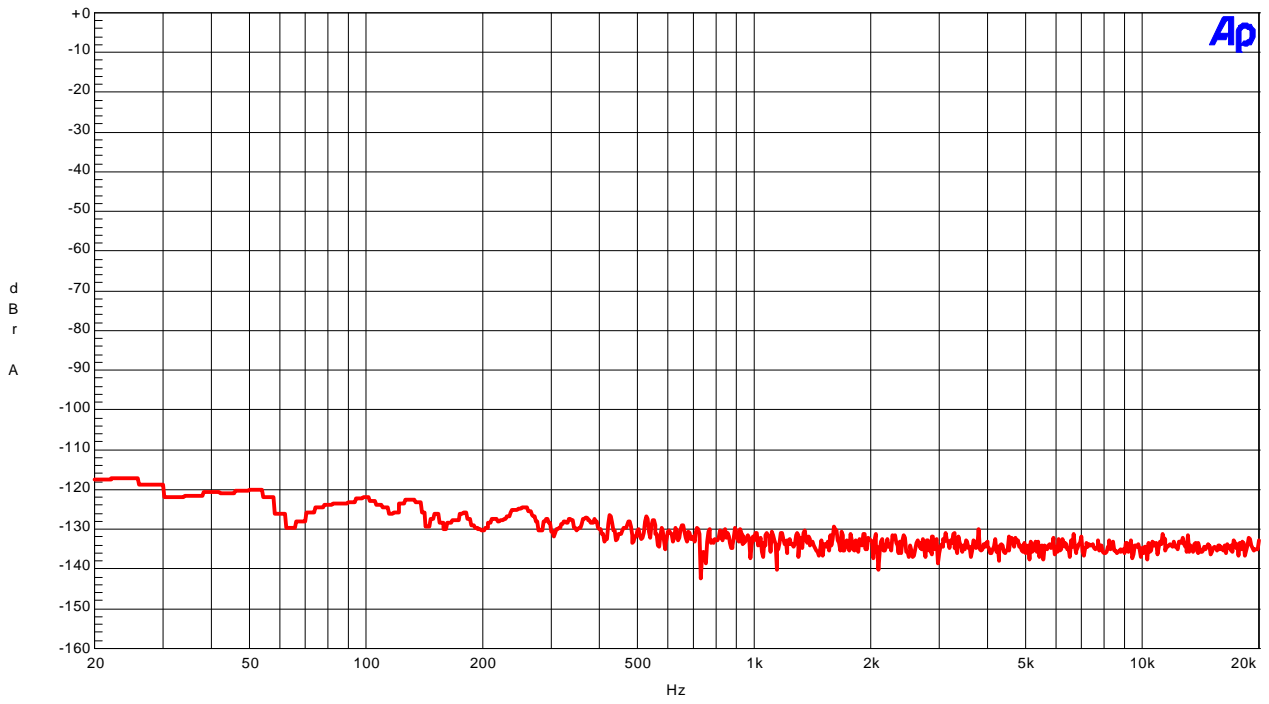

FFT (Input="0"data)

(DAC fs=44.1kHz)

AKM

AK4527 DAC THD + N vs Amplitude(fin=1kHz)

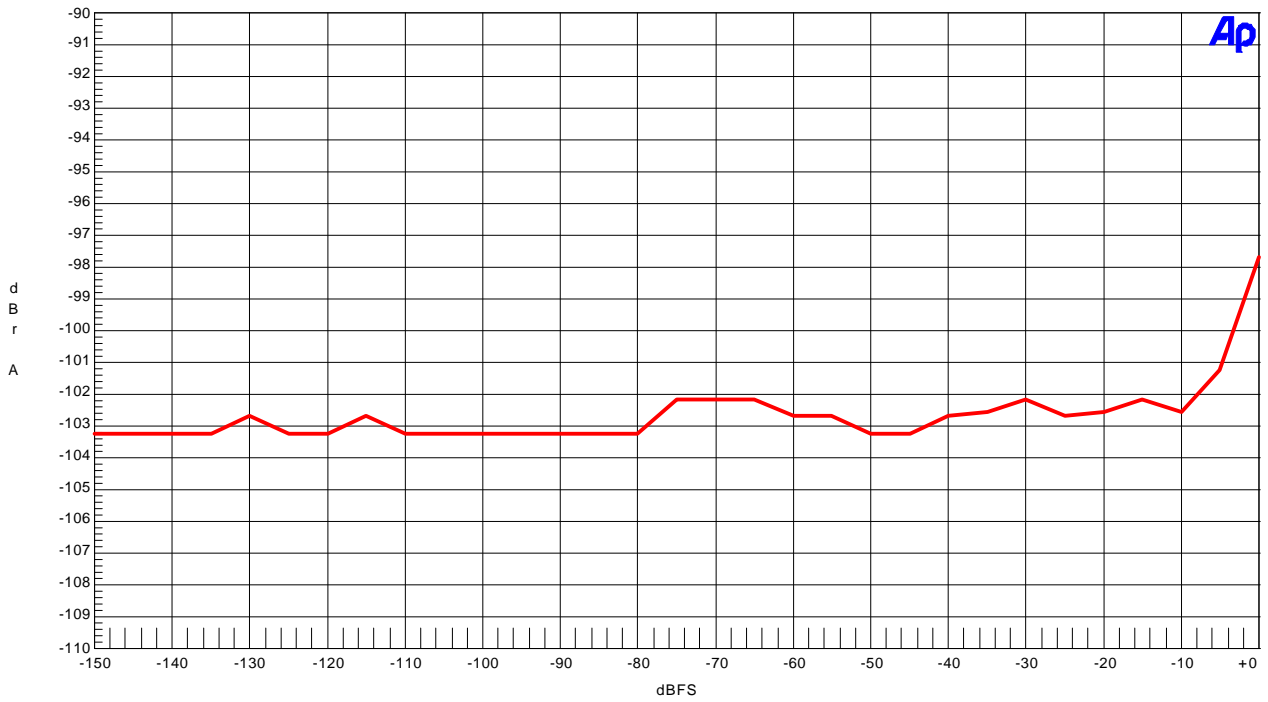

THD + N vs Amplitude(fin=1kHz)

AKM

AK4527 DAC THD + N vs Input Frequency(Input Level=0dBFS)

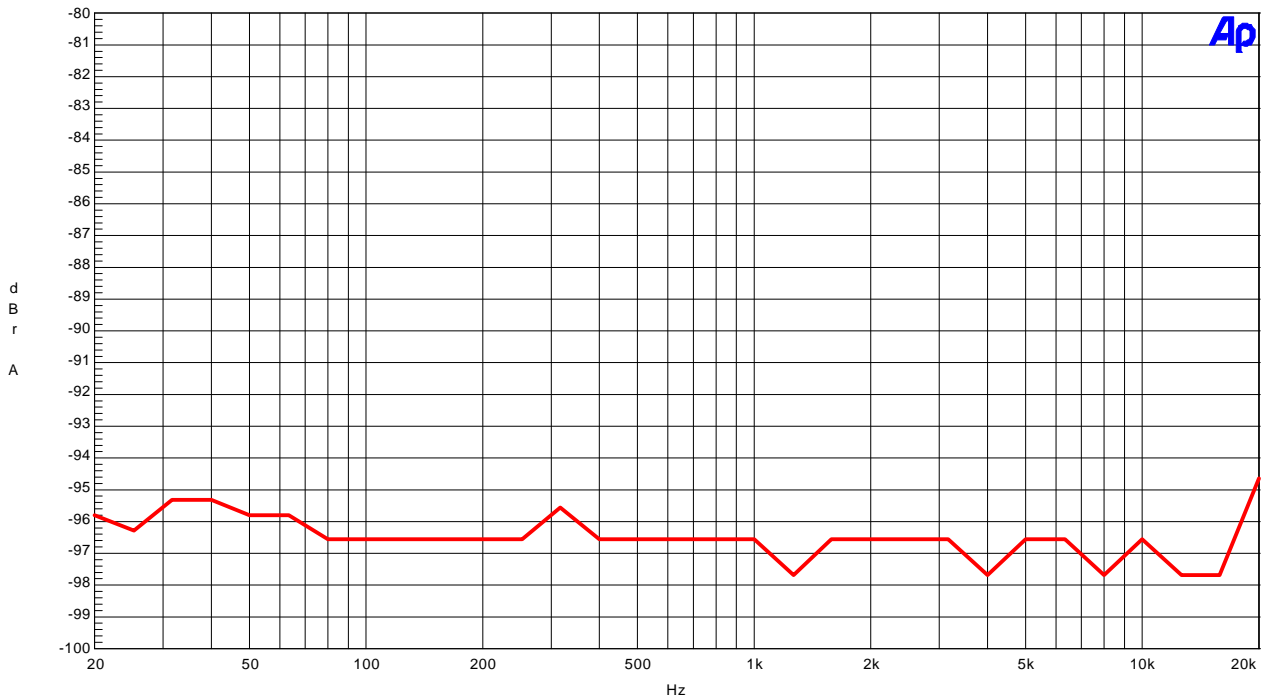

THD + N vs Input Frequency (Input=0dBFS)

(DAC fs=44.1kHz)  
AK4527 DAC Linearity

AKM

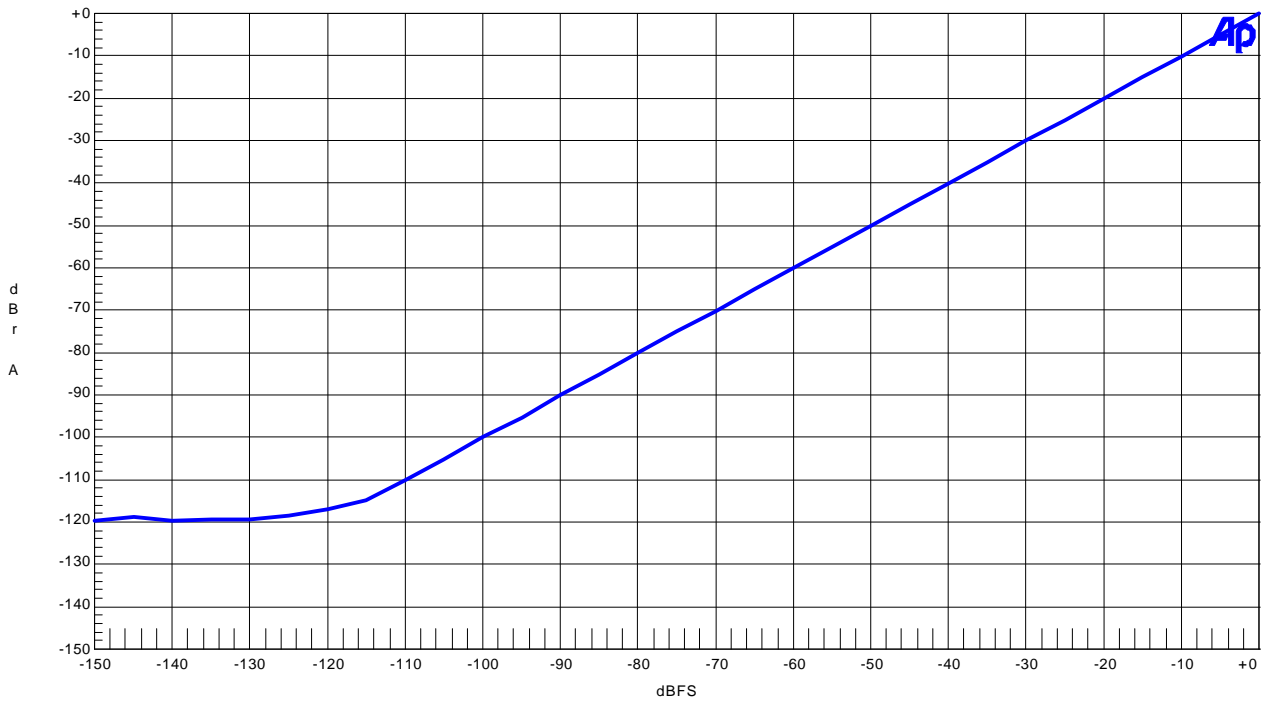

Linearity(fin=1kHz)

AKM

AK4527 DAC Frequency Response

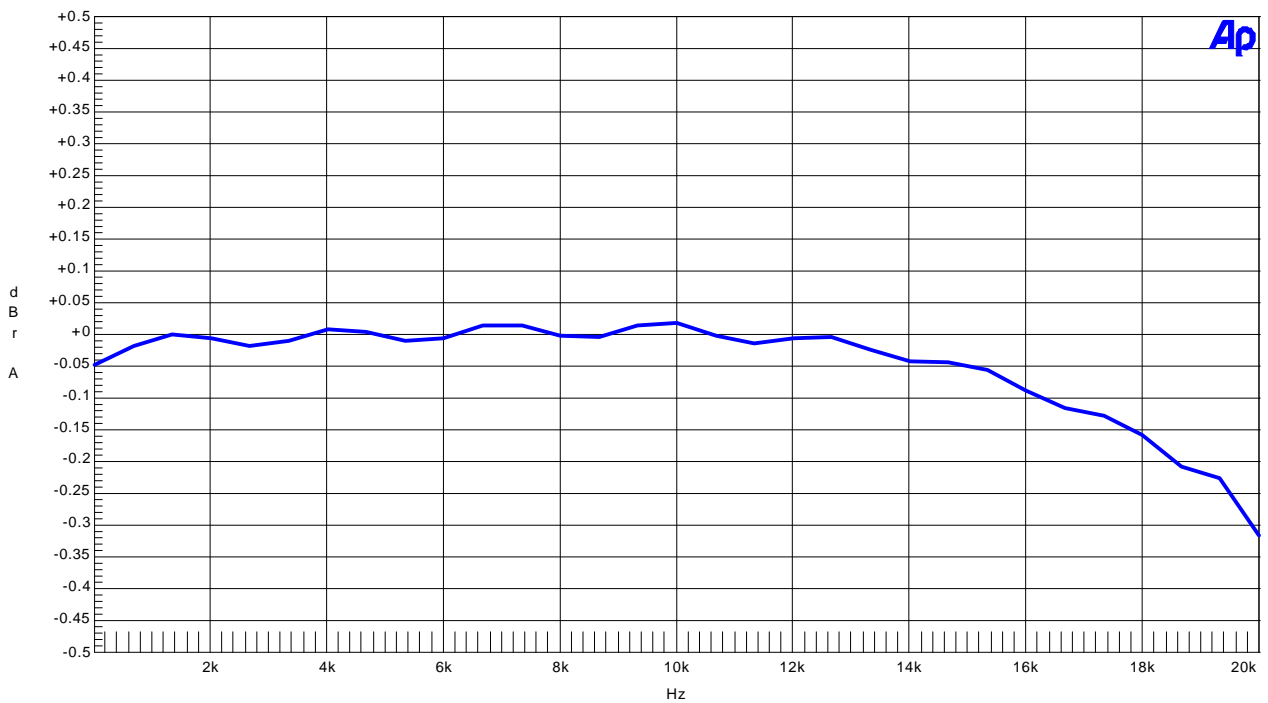

Frequency Response(Input Level=0dBFS)  
(including external RC filter)

AKM (DAC fs=44.1kHz)  
AK4527 DAC Crosstalk

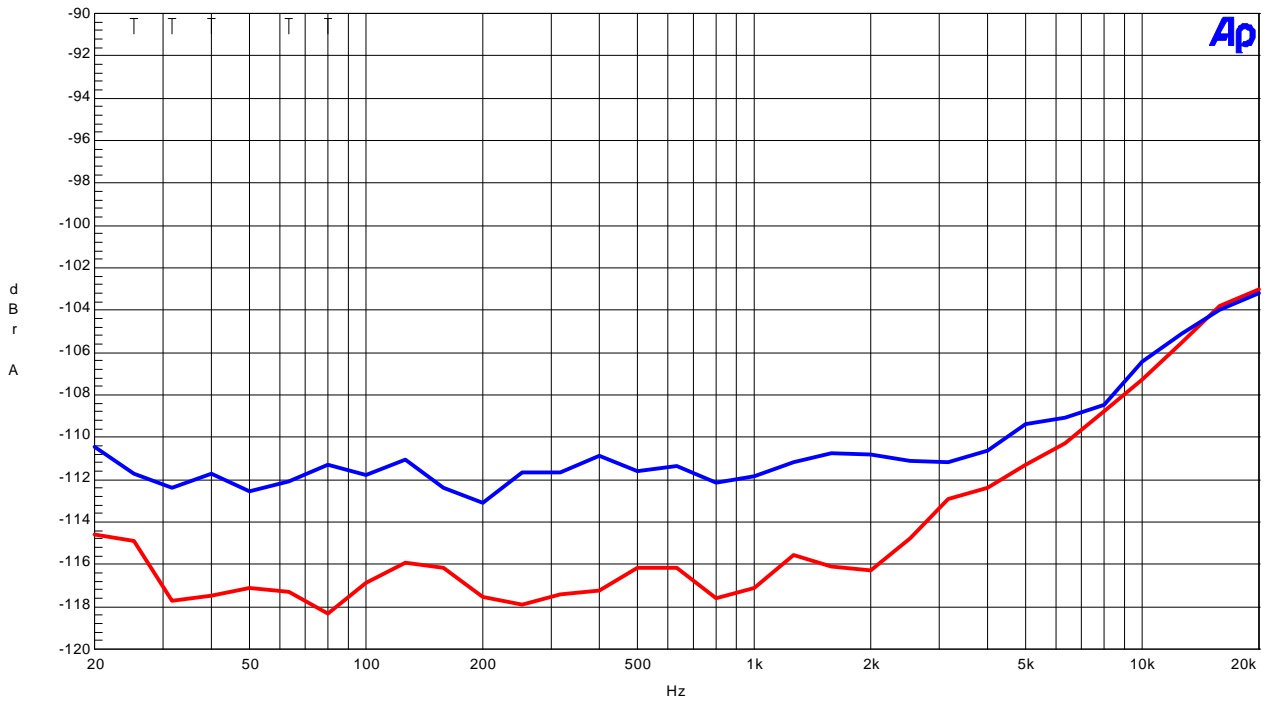

Crosstalk(Upper=Rch, Lower=Lch)

AKM (DAC fs=96kHz)  
AK4527 FFT (Input Level=0dBFS, fin=1kHz, notch)

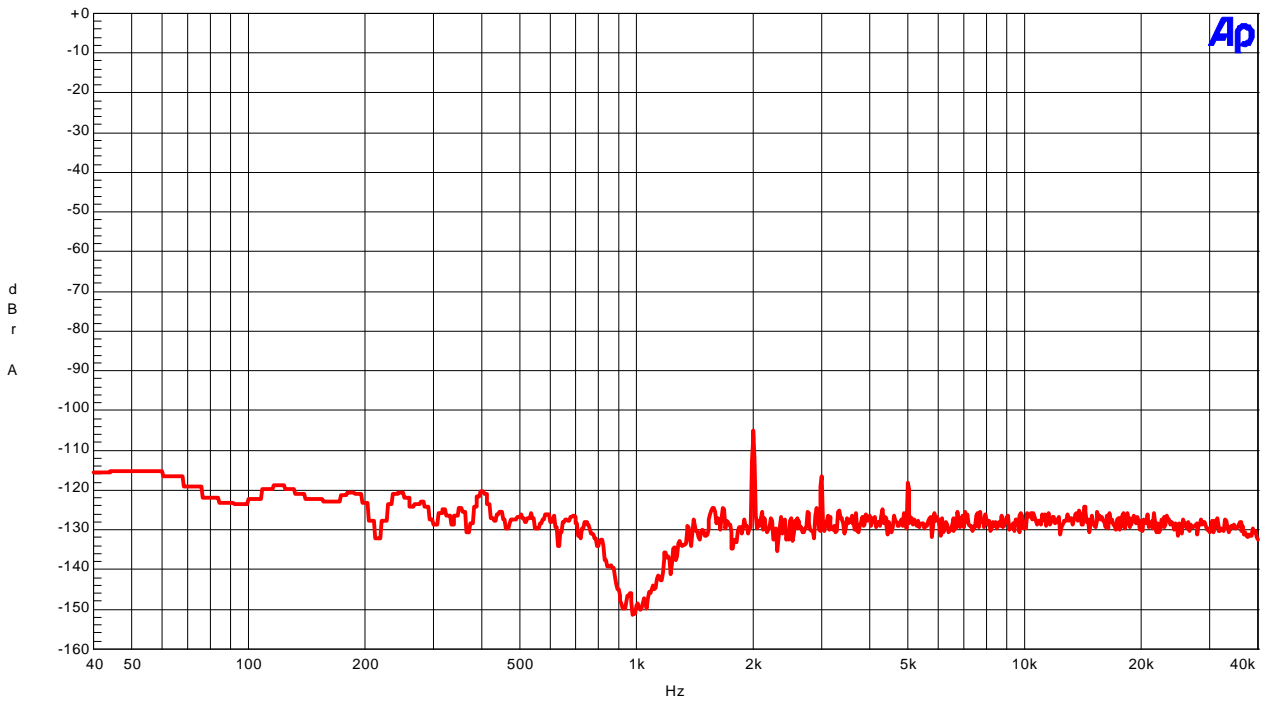

FFT (Input=0dBFS, fin=1kHz, Notch)

AKM AK4527 FFT (Input Level=-60dBFS, fin=1kHz)

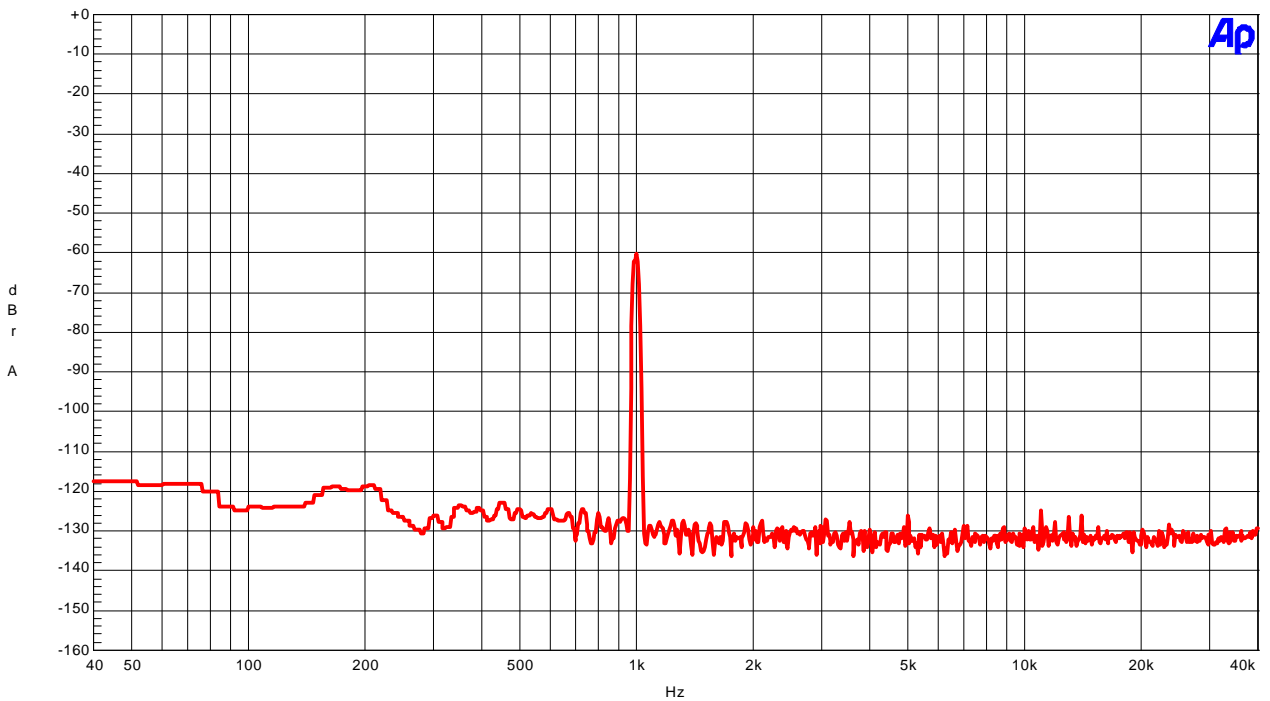

FFT (Input=-60dBFS,fin=1kHz)



AKM  
(DAC fs=96kHz)  
AK4527 FFT (Input="0" data)

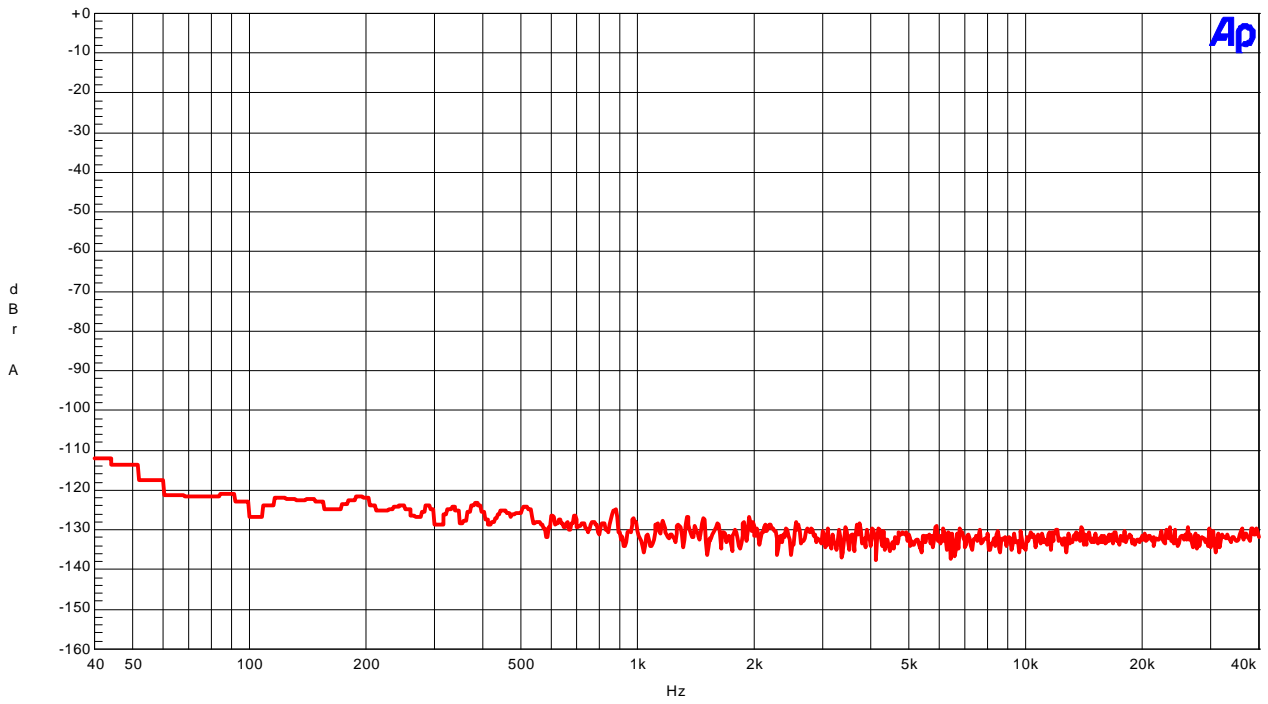

FFT (Input="0" data)

AKM  
AK4527 THD + N vs Amplitude (fin=1kHz)

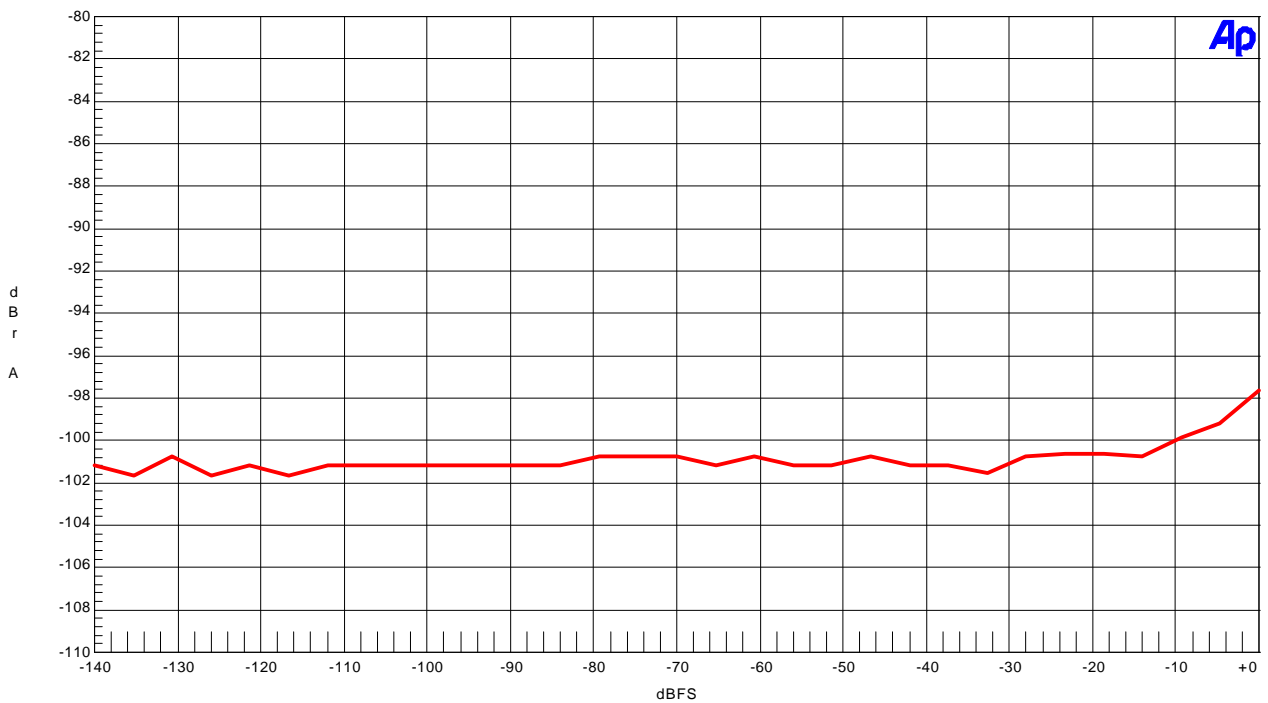

THD + N vs Amplitude (fin=1kHz)

AKM (DAC fs=96kHz)  
AK4527 THD + N vs Input Frequency (Input Frequency)

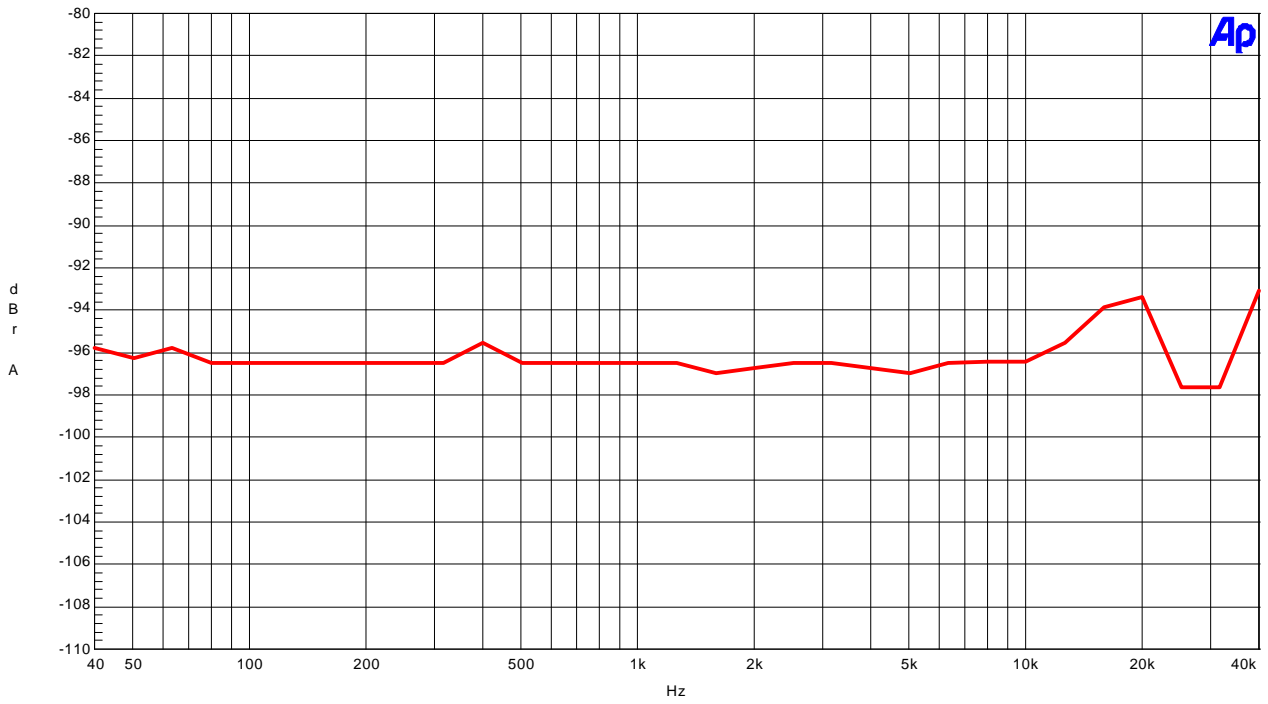

THD + N vs Input Frequency (Input=0dBFS)

AKM AK4527 Linearity

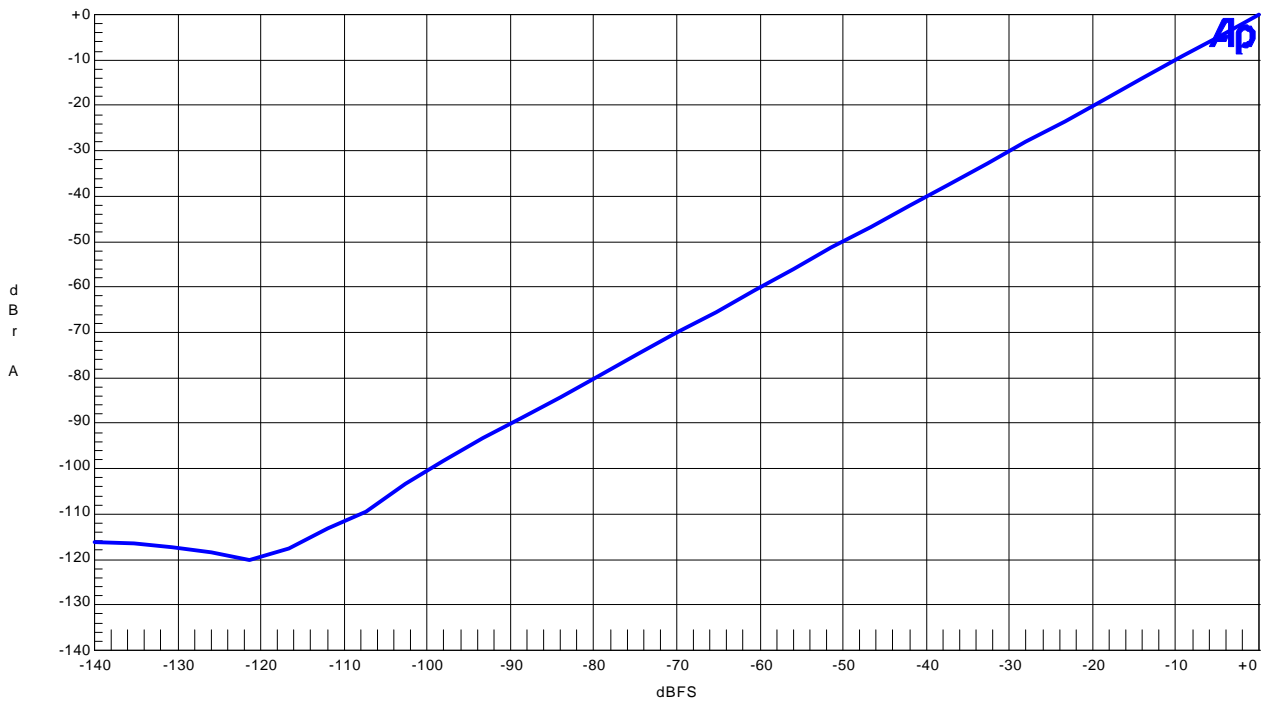

Linearity(fin=1kHz)

AKM (DAC fs=96kHz)  
AK4527 Frequency Response

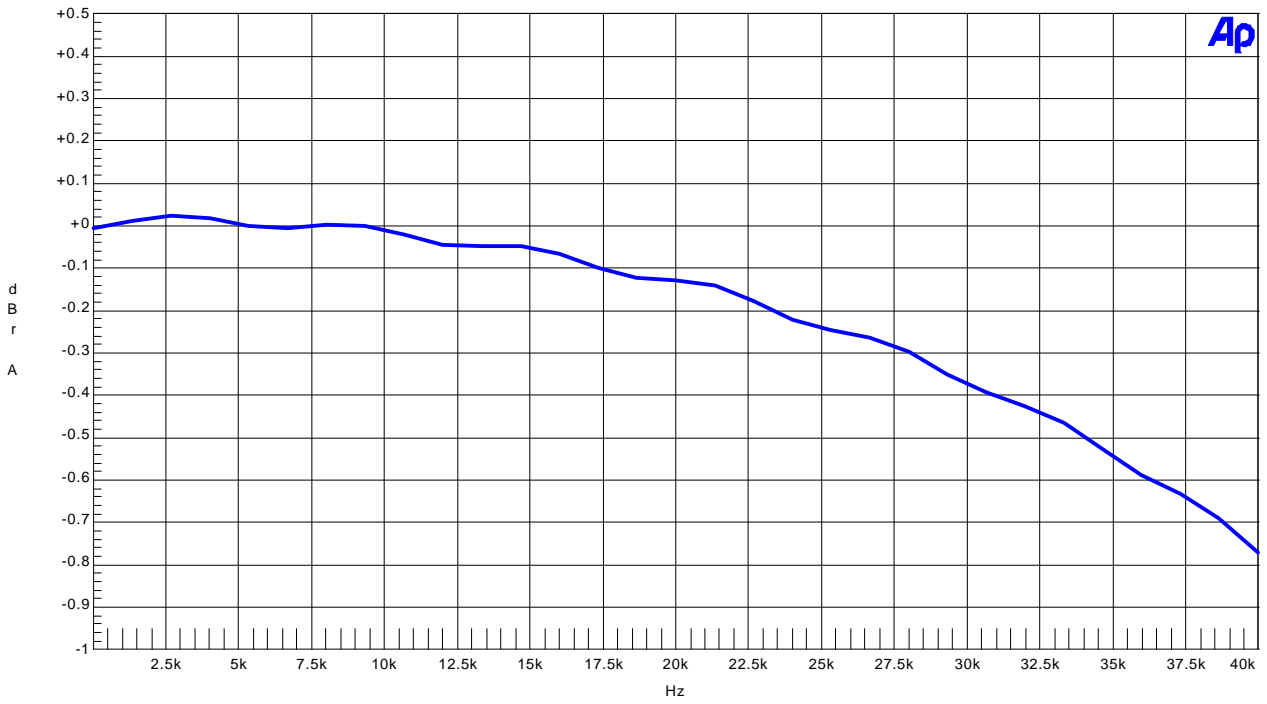

Frequency Response(Input Level=0dBFS)  
(including external RC filter)  
AKM AK4527 Crosstalk

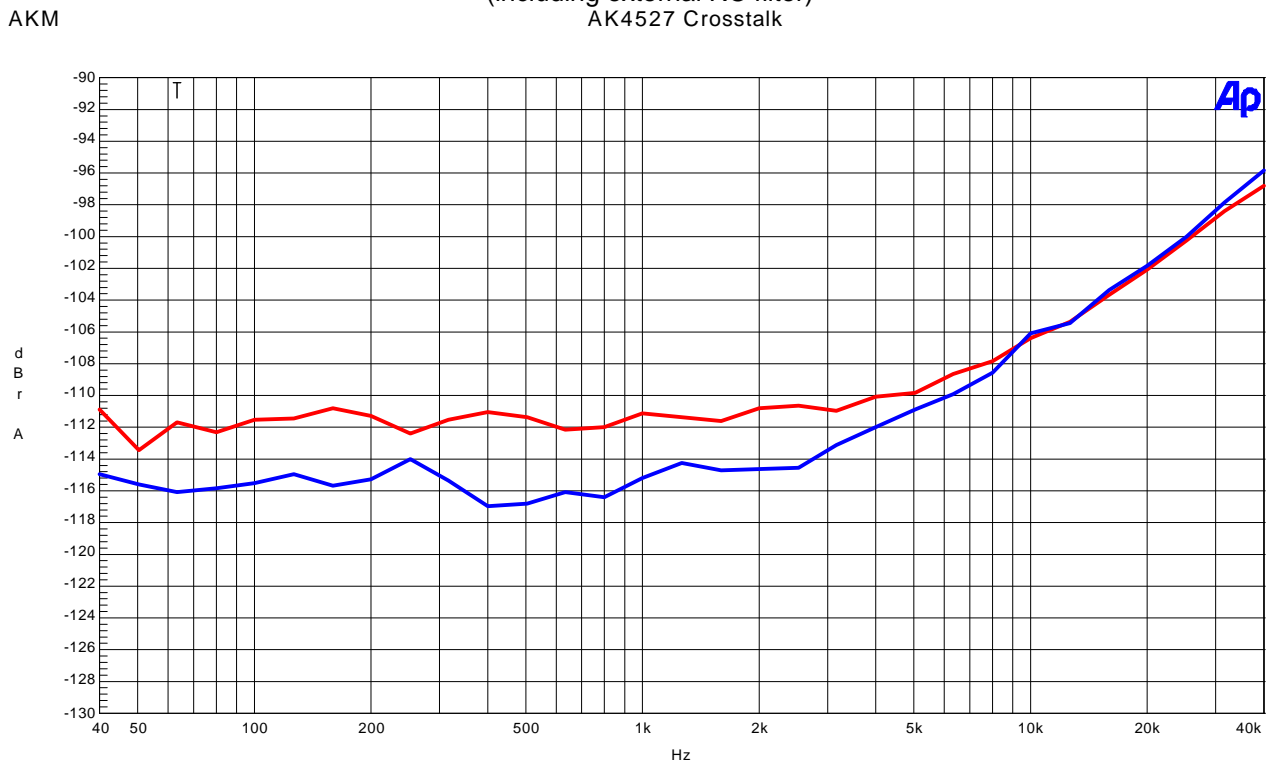

Crosstalk (Upper=Rch, Lower=Lch)

IMPORTANT NOTICE

- These products and their specifications are subject to change without notice. Before considering any use or application, consult the Asahi Kasei Microsystems Co., Ltd. (AKM) sales office or authorized distributor concerning their current status.
- AKM assumes no liability for infringement of any patent, intellectual property, or other right in the application or use of any information contained herein.
- Any export of these products, or devices or systems containing them, may require an export license or other official approval under the law and regulations of the country of export pertaining to customs and tariffs, currency exchange, or strategic materials.
- AKM products are neither intended nor authorized for use as critical components in any safety, life support, or other hazard related device or system, and AKM assumes no responsibility relating to any such use, except with the express written consent of the Representative Director of AKM. As used here:
  - (a) A hazard related device or system is one designed or intended for life support or maintenance of safety or for applications in medicine, aerospace, nuclear energy, or other fields, in which its failure to function or perform may reasonably be expected to result in loss of life or in significant injury or damage to person or property.
  - (b) A critical component is one whose failure to function or perform may reasonably be expected to result, whether directly or indirectly, in the loss of the safety or effectiveness of the device or system containing it, and which must therefore meet very high standards of performance and reliability.
- It is the responsibility of the buyer or distributor of an AKM product who distributes, disposes of, or otherwise places the product with a third party to notify that party in advance of the above content and conditions, and the buyer or distributor agrees to assume any and all responsibility and liability for and hold AKM harmless from any and all claims arising from the use of said product in the absence of such notification.

**AK4527B Control Program operation manual**

1. Connect IBM-AT compatible PC with Eva-board by 10-line type flat cable (packed with Eva-board).  
Take care of the direction of 10pin Header (Refer to manual of Eva-board).
2. Start up "WINDOWS 95" or "WINDOWS 98".
3. Insert the floppy-disk packed with Eva-board into the floppy-disk drive.
4. Set up "MS-DOS" from start menu.
5. Change directory to the floppy-disk drive(ex.a:) at MS-DOS prompt.
6. Type "4527b".
7. Then follow the displayed comment (See the following).

===== <<Operating flow>> =====  
Write data/ Display register map/ Reset etc. → loop  
=====

At first the following message is displayed:

```
***** AK4527B Control Program ver 2.0 , '00/9 *****
copyright(c) 2000, Asahi Kasei Microsystems co.,ltd.
All rights reserved.
```

Then the following default register map is displayed (Loop starts from here):

```
AK4527B : 3-wire Serial control mode CAD1-0=01 -----
ADDR = 00 : 00 <Control 1> ( 0 0 0 0 DIF1 DIF0 0 SMUTE )
ADDR = 01 : 00 <Control 2> ( 0 0 LOOP1 LOOP0 SDOS DFS ACKS 0 )
ADDR = 02 : 00 <L1 ATT> ( ATT7 ATT6 ATT5 ATT4 ATT3 ATT2 ATT1 ATT0 )
ADDR = 03 : 00 <R1 ATT> ( ATT7 ATT6 ATT5 ATT4 ATT3 ATT2 ATT1 ATT0 )
ADDR = 04 : 00 <L2 ATT> ( ATT7 ATT6 ATT5 ATT4 ATT3 ATT2 ATT1 ATT0 )
ADDR = 05 : 00 <R2 ATT> ( ATT7 ATT6 ATT5 ATT4 ATT3 ATT2 ATT1 ATT0 )
ADDR = 06 : 00 <L3 ATT> ( ATT7 ATT6 ATT5 ATT4 ATT3 ATT2 ATT1 ATT0 )
ADDR = 07 : 00 <R3 ATT> ( ATT7 ATT6 ATT5 ATT4 ATT3 ATT2 ATT1 ATT0 )
ADDR = 08 : 00 <DEM> ( 0 0 DEMA1 DEMA0 DEMB1 DEMB0 DEMC1 DEMC0 )
ADDR = 09 : 01 <CLK Mode> ( 0 0 0 0 0 0 0 RSTN )
ADDR = 0A : 3F <DZF> ( OVFE 0 DZFM2 DZFM1 DZFM0 PWVRN PWADN PWDAN )

Input 1(Write), R(Reset), T(Table), I(Increment) or D(Decrement) :
```

1) If you input “1”, you can write data to AK4527B.

```
You can write data to AK4527B
Input Register Address (2 figure, hex) (00-0A) =
```

Input register address in 2 figures of hexadecimal.

Then current data of this address is displayed:

```
AK4527B
ADDR = 00 : 08 <Control 1> ( 0 0 0 0 DIF1 DIF0 0 SMUTE )
                          0 0 0 0 1 0 0 0
Input Register Data (2 figure, hex) (00-FF) =
```

You can write control data to this address. Input control data in 2 figures of hexadecimal.

Refer to datasheet of AK4527B.

Then the data written to this address is displayed:

```
AK4527B
ADDR = 00 : 0C <Control 1> ( 0 0 0 0 DIF1 DIF0 0 SMUTE )
                          0 0 0 0 1 1 0 0
```

- 2) If you input “R” or “r”, this program writes default data to all register addresses.
- 3) If you input “T” or “t”, current register map is displayed.
- 4) If you input “I” or “i”, this program increment data of current address by 1.
- 5) If you input “D” or “d”, this program decrement data of current address by 1.
- 6) If you input “S” or “s”, this program is terminated.

**AK4112A Control Program operation manual**

1. Connect IBM-AT compatible PC with Eva-board by 10-line type flat cable (packed with Eva-board).  
Take care of the direction of 10pin Header (Refer to manual of Eva-board).
2. Start up "WINDOWS 95" or "WINDOWS 98".
3. Insert the floppy-disk packed with Eva-board into the floppy-disk drive.
4. Set up "MS-DOS" from start menu.
5. Change directory to the floppy-disk drive(ex.a:) at MS-DOS prompt.
6. Type "4112".
7. Then follow the displayed comment (See the following).

===== <<Operating flow>> =====  
Write data/ Display register map/ Reset etc. → loop  
=====

At first the following message is displayed:

```
***** AK4112 Control Program ver 2.0 , '00/1 *****
copyright(c) 2000, Asahi Kasei Microsystems co.,ltd.
All rights reserved.
```

Then the following is displayed:

After chip address is defined, the following default register map is displayed (Loop starts from here):

```
AK4112 Register Map
ADDR = 00 : 03 <CLK PD ctrl> (0    BCU   CM1   CM0   OCKS1 OCKS0 PWN   RSTN )
ADDR = 01 : 80 <I/O   ctrl> (MPAR  MTSC  CS12  XTE   IPS1  IPS0  OPS1  OPS0 )
ADDR = 02 : 4A <FMT DM ctrl> (V/TX  DIF2  DIF1  DIF0  DEAU  DEM1  DEM0  DFS )
ADDR = 03 : 00 <RCV STAT 1> (ERF   0    AUDIO AUTO  PEM   FS1   FS0   RFS96)
ADDR = 04 : 00 <RCV STAT 2> (CV    STC   CRC   UNLOCK V    FRERR BIP   PAR )
ADDR = 05 : 00 <ChA STAT 0> (CA7   CA6   CA5   CA4   CA3   CA2   CA1   CA0 )
ADDR = 06 : 00 <ChA STAT 1> (CA15  CA14  CA13  CA12  CA11  CA10  CA9   CA8 )
ADDR = 07 : 00 <ChA STAT 2> (CA23  CA22  CA21  CA20  CA19  CA18  CA17  CA16)
ADDR = 08 : 00 <ChA STAT 3> (CA31  CA30  CA29  CA28  CA27  CA26  CA25  CA24)
ADDR = 09 : 00 <ChB STAT 0> (CB7   CB6   CB5   CB4   CB3   CB2   CB1   CB0 )
ADDR = 0A : 00 <ChB STAT 1> (CB15  CB14  CB13  CB12  CB11  CB10  CB9   CB8 )
ADDR = 0B : 00 <ChB STAT 2> (CB23  CB22  CB21  CB20  CB19  CB18  CB17  CB16)
ADDR = 0C : 00 <ChB STAT 3> (CB31  CB30  CB29  CB28  CB27  CB26  CB25  CB24)
ADDR = 0D : 00 <BstPre Pc 0> (PC7   PC6   PC5   PC4   PC3   PC2   PC1   PC0 )
ADDR = 0E : 00 <BstPre Pc 1> (PC15  PC14  PC13  PC12  PC11  PC10  PC9   PC8 )
ADDR = 0F : 00 <BstPre Pd 0> (PD7   PD6   PD5   PD4   PD3   PD2   PD1   PD0 )
ADDR = 10 : 00 <BstPre Pd 1> (PD15  PD14  PD13  PD12  PD11  PD10  PD9   PD8 )
ADDR = 11 : 02 <Count ctrl> (0     0     0     0     0     EFH1  EFH0  XFS96)
Input 0(Read), 1(Write), R(Reset), T(Table) or S(Stop) :
```

1) If you input “0”, you can read data from AK4112A.

You can read data from AK4112  
 Input Register Address (2 figure, hex) (00H-11H) =

Input register address in 2 figures of hexadecimal.  
 Then current data of this address is displayed:

```
AK4112A
ADDR = 00 : 03 <CLK PD ctrl> (0    BCU   CM1   CM0   OCKS1 OCKS0 PWN   RSTN)
                          0    0    0    0    0    0    1    1
```

2) If you input “1”, you can write data to AK4112A.

You can write data to AK4112  
 Input Register Address (2 figure, hex) (00H-02H or 11H) =

Input register address in 2 figures of hexadecimal.  
 Then current data of this address is displayed:

```
AK4112A
ADDR = 00 : 03 <CLK PD ctrl> (0    BCU   CM1   CM0   OCKS1 OCKS0 PWN   RSTN)
                          0    0    0    0    0    0    1    1
Input Register Data (2 figure, hex) =
```

You can write control data to this address. Input control data in 2 figures of hexadecimal.  
 Refer to datasheet of AK4112A.

Then the data written to this address is displayed:

```
AK4112
ADDR = 00 : 23 <CLK PD ctrl> (0    BCU   CM1   CM0   OCKS1 OCKS0 PWN   RSTN)
                          0    0    1    0    0    0    1    1
```

3) If you input “R” or “r”, this program writes default data to all register addresses.

4) If you input “T” or “t”, current register map is displayed.

5) If you input “S” or “s”, this program is terminated.



**AK4353 Control Program operation manual**

1. Connect IBM-AT compatible PC with Eva-board by 10-line type flat cable (packed with Eva-board).  
Take care of the direction of 10pin Header (Refer to manual of Eva-board).
2. Start up "WINDOWS 95" or "WINDOWS 98".
3. Insert the floppy-disk packed with Eva-board into the floppy-disk drive.
4. Set up "MS-DOS" from start menu.
5. Change directory to the floppy-disk drive(ex.a:) at MS-DOS prompt.
6. Type "4353".
7. Then follow the displayed comment (See the following).

===== <<Operating flow>> =====  
Write data/ Display register map/ Reset etc. → loop  
=====

At first the following message is displayed:

```
***** AK4353 Control Program ver 3.0 , '00/2 *****
copyright(c) 2000, Asahi Kasei Microsystems co.,ltd.
All rights reserved.
```

Then the following default register map is displayed (Loop starts from here):

```
3-wire Serial control mode CAD1-0=11 -----
ADDR = 00 : 0B <Control 1> ( 0 0 0 0 DIF2 DIF1 DIF0 RSTN )
ADDR = 01 : 01 <Control 2> ( 0 0 DFS1 DFS0 CKS2 CKS1 CKS0 RSTN )
ADDR = 02 : 94 <Control 3> ( PL3 PL2 PL1 PL0 DEM1 DEM0 ATC SMUTE)
ADDR = 03 : FF <Lch ATT> ( ATT7 ATT6 ATT5 ATT4 ATT3 ATT2 ATT1 ATT0 )
ADDR = 04 : FF <Rch ATT> ( ATT7 ATT6 ATT5 ATT4 ATT3 ATT2 ATT1 ATT0 )
ADDR = 05 : 00 <TX> ( 0 0 0 0 0 0 V TXE )
ADDR = 06 : 00 <Ch Status 1>( 0 CS29 CS28 CS24 CS3 CS2 CS2 CS1 )
ADDR = 07 : 04 <Ch Status 2>( CS15 CS14 CS13 CS12 CS11 CS10 CS9 CS8 )
```

Input 1(Write), R(Reset), T(Table), I(Increment), D(Decrement) or S(Stop) :

1) If you input “1”, you can write data to AK4353.

You can write data to AK4353  
Input Register Address (2 figure, hex) (00-07) =

Input register address in 2 figures of hexadecimal.

Then current data of this address is displayed:

```
ADDR = 00 : 0B <Control 1> ( 0 0 0 0 DIF2 DIF1 DIF0 RSTN )
                          0 0 0 0 1 0 1 1
```

Input Register Data (2 figure, hex) (00-FF) =

You can write control data to this address. Input control data in 2 figures of hexadecimal.

Refer to datasheet of AK4353.

Then the data written to this address is displayed:

```
ADDR = 00 : 09 <Control 1> ( 0 0 0 0 DIF2 DIF1 DIF0 RSTN )
                          0 0 0 0 1 0 0 1
```

2) If you input “R” or “r”, this program writes default data to all register addresses.

3) If you input “T” or “t”, current register map is displayed.

4) If you input “I” or “i”, this program increment data of current address by 1 (only for addr=03H or 04H). You can increment ATT value by 1step.

5) If you input “D” or “d”, this program decrement data of current address by 1 (only for addr=03H or 04H). You can decrement ATT value by 1step.

6) If you input “S” or “s”, this program is terminated.

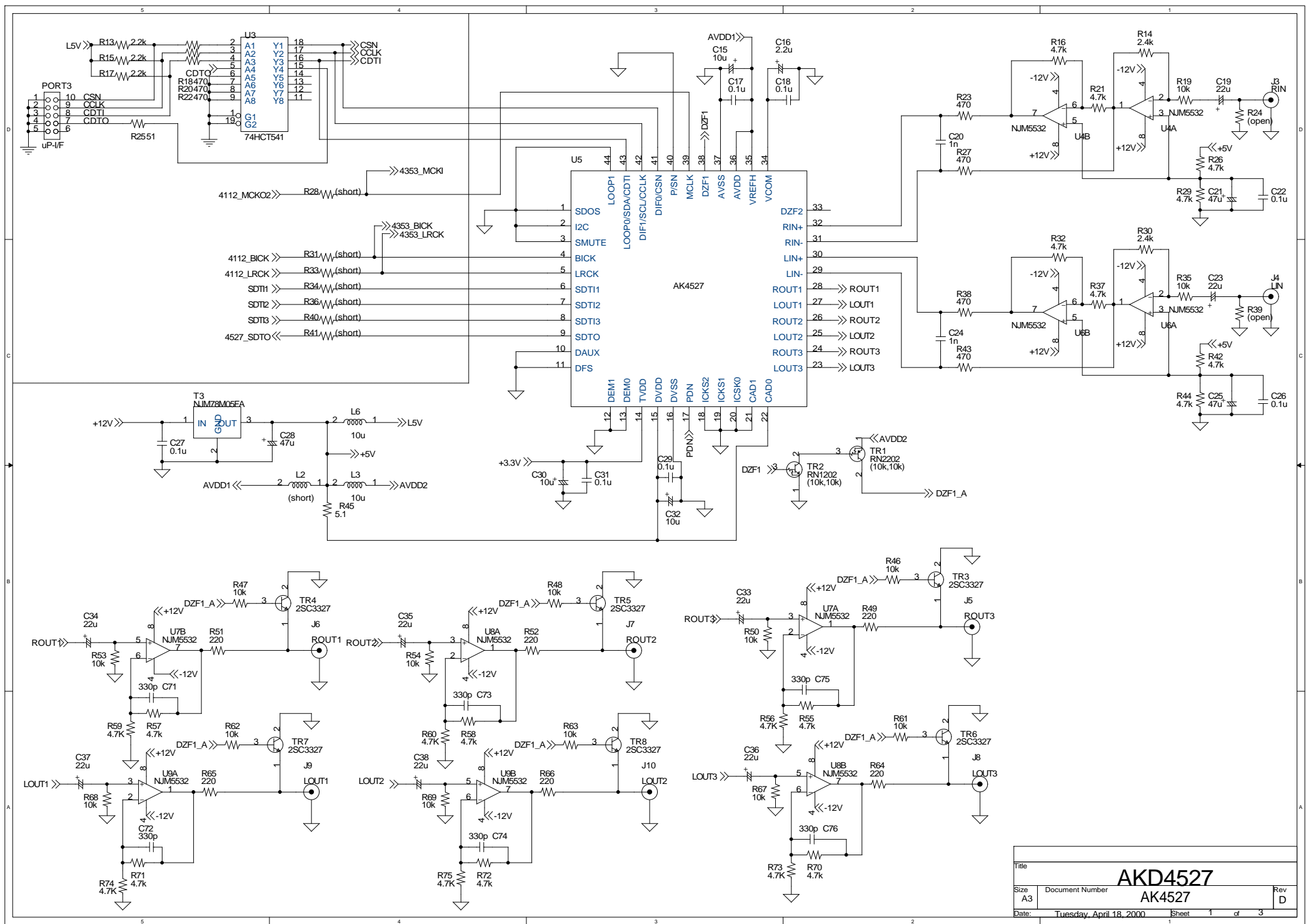

Title			<b>AKD4527</b>		
Size	Document Number	AK4527			Rev
A3					D
Date:	Tuesday, April 18, 2000	Sheet	1	of	3

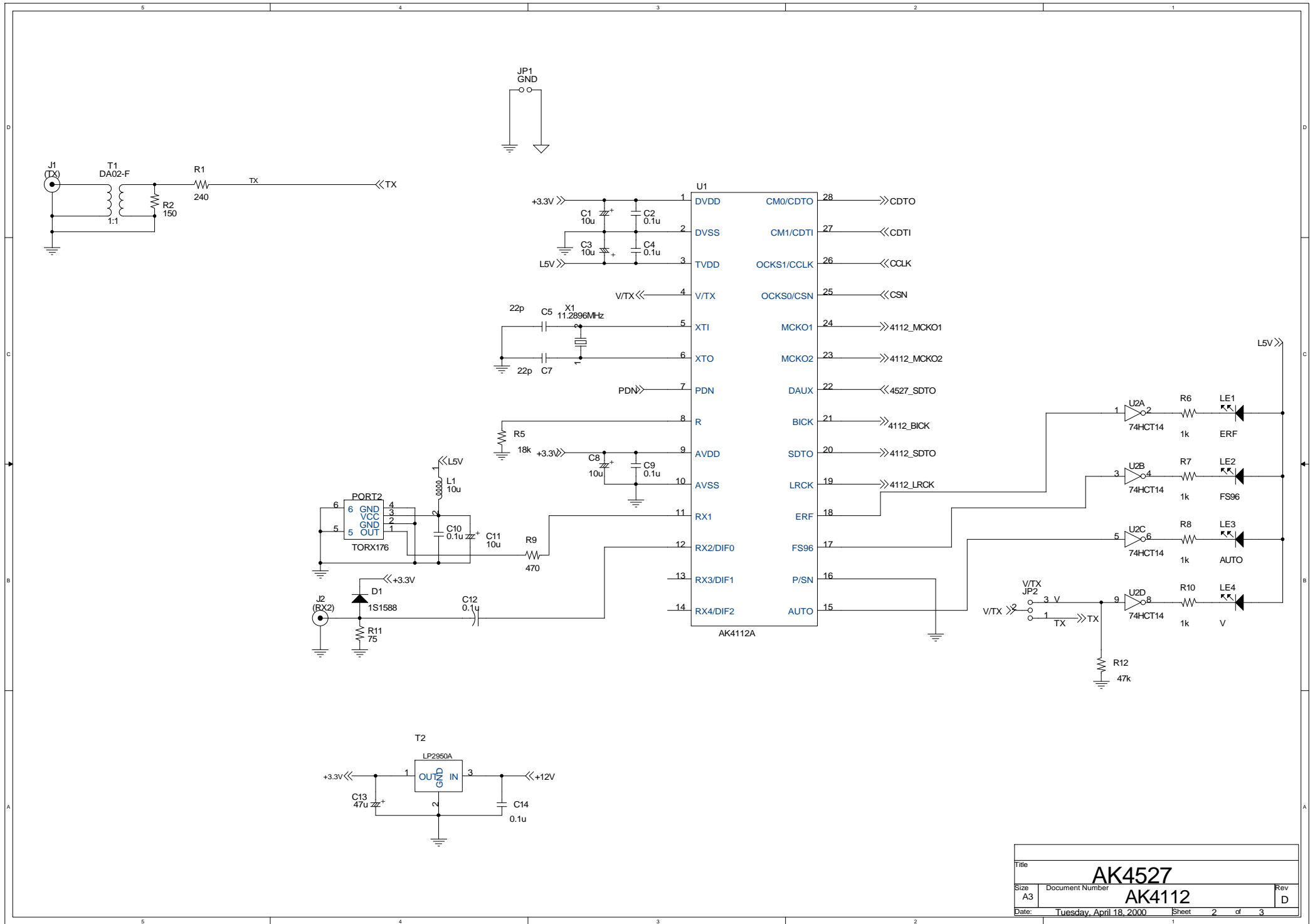

Title			<b>AK4527</b>		
Size	Document Number				Rev
A3	AK4112				D
Date:	Tuesday, April 18, 2000	Sheet	2	of	3

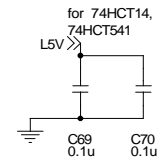
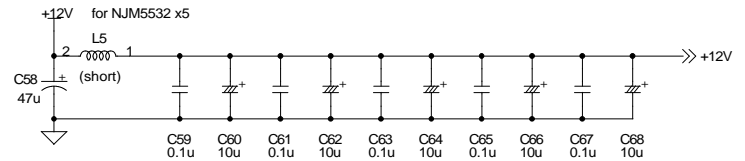
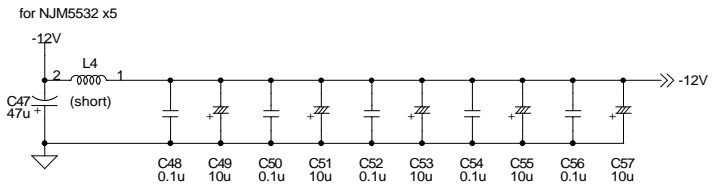
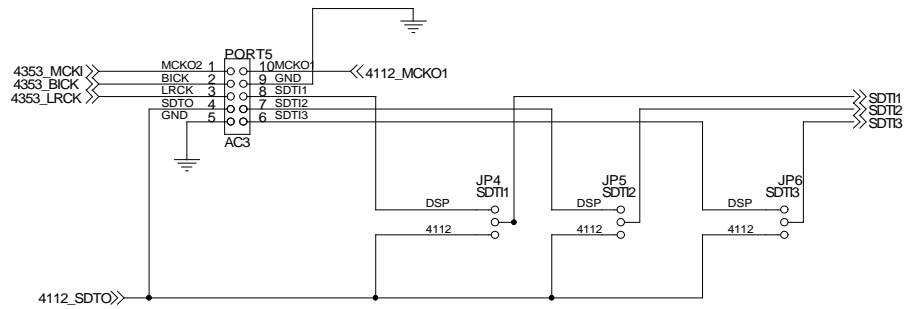
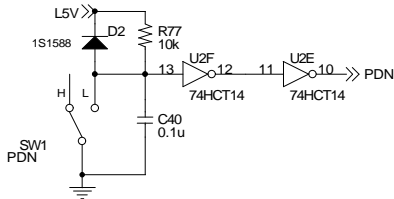
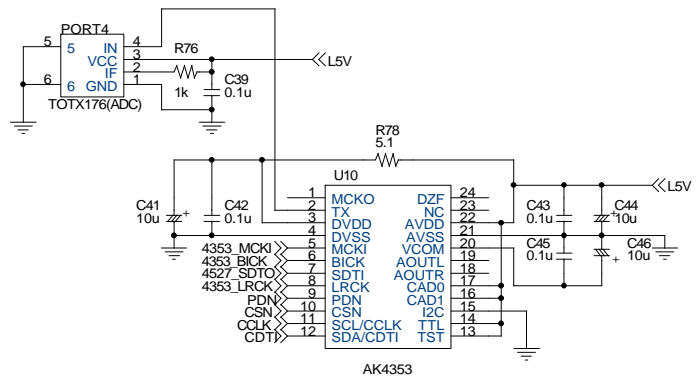

Title			<b>AKD4527</b>		
Size	Document Number	Interface			Rev
A3					D
Date:	Wednesday, April 19, 2000	Sheet	3	of	3

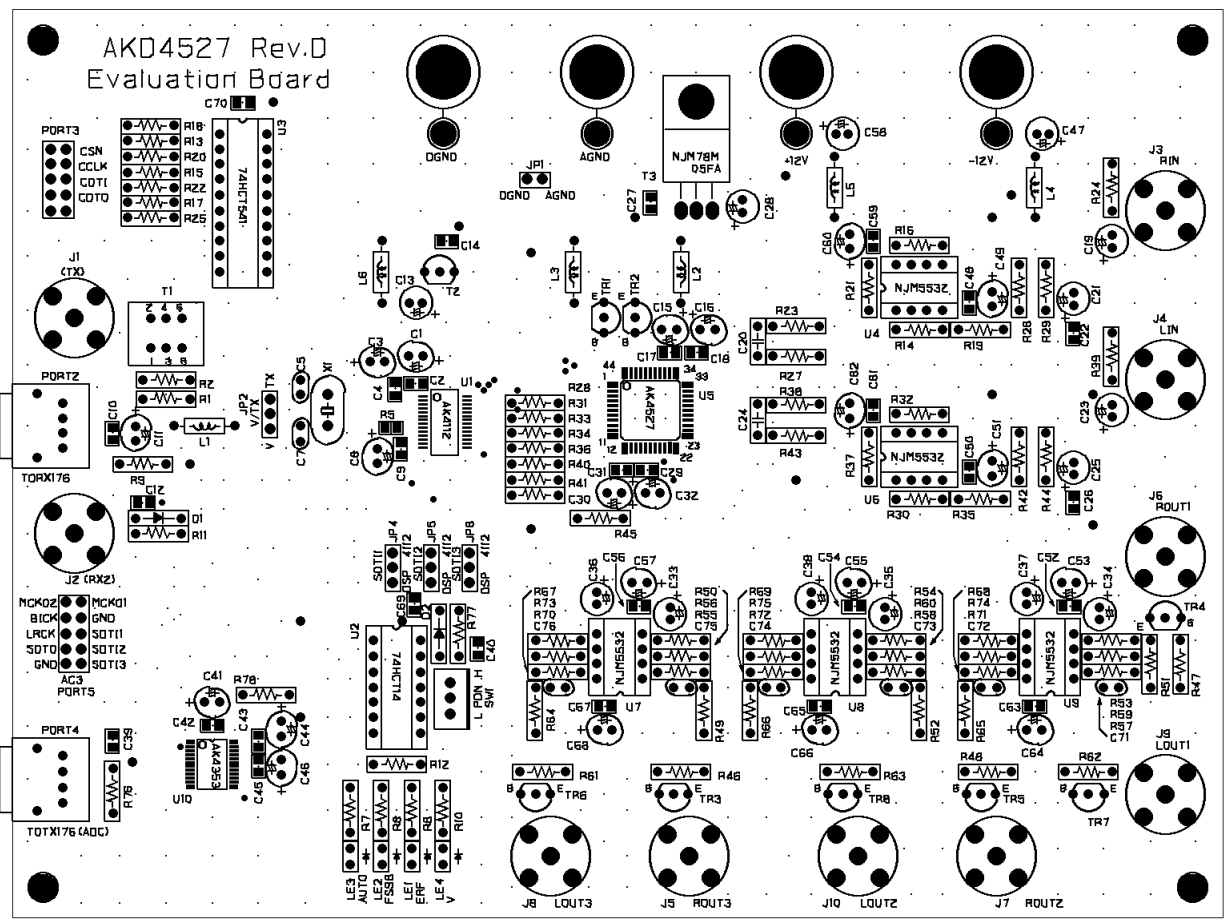

L1 部品面 レジスト シルク AKD4527 Rev.D

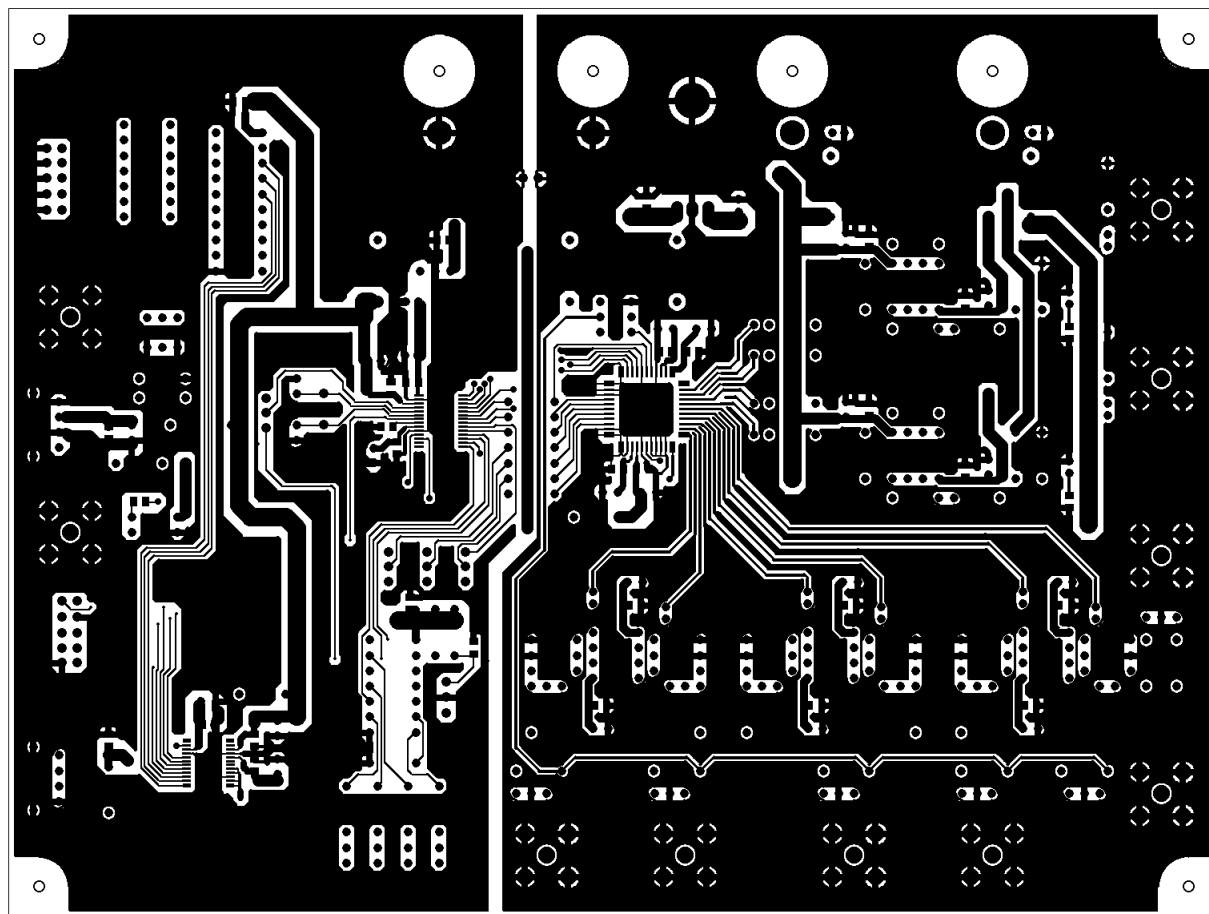

L1 部品面 パターン

AKD4527 Rev.D

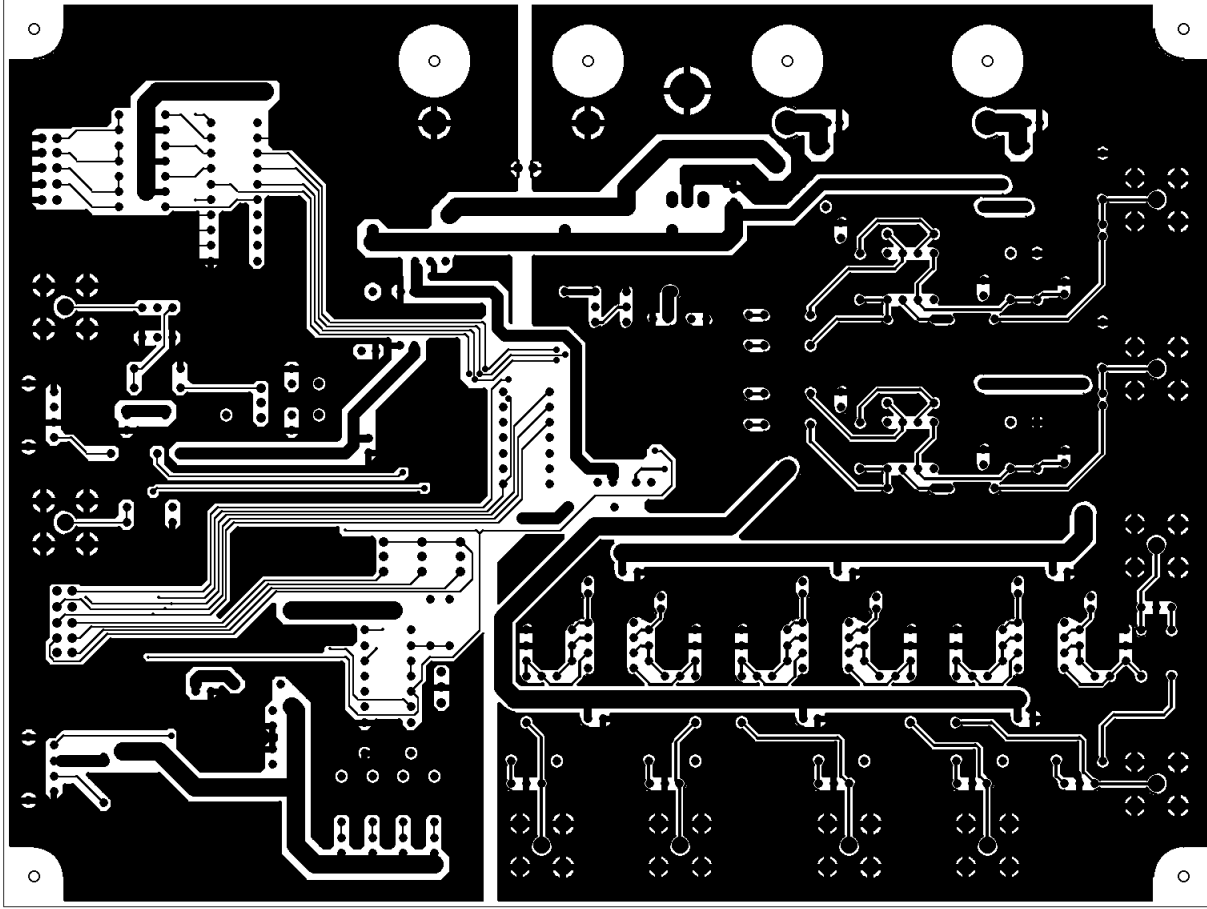

LS 基板 14-1 > AKD42S1 Rev.D