

Negative Voltage Hot Plug Controller

The ISL6142, ISL6152 are 14 pin, negative voltage hot plug controllers that allow a board to be safely inserted and removed from a live backplane. Inrush current is limited to a programmable value by controlling the gate voltage of an external N-channel pass transistor. The pass transistor is turned off if the input voltage is less than the Under-Voltage threshold, or greater than the Over-Voltage threshold. The PWRGD/PWRGD outputs can be used to directly enable a power module. When the Gate and DRAIN voltages are both considered good, the output is latched in the active state.

The IntelliTrip™ electronic circuit breaker and programmable current limit features protect the system against short circuits. When the Over-Current threshold is exceeded, the output current is limited for a time-out period before the circuit breaker trips and shuts down the FET. The time-out period is programmable with an external capacitor connected to the CT pin. If the fault disappears before the programmed time-out, normal operation resumes. In addition, the IntelliTrip™ electronic circuit breaker has a fast Hard Fault shutdown, with a threshold set at 4 times the Over-Current trip point. When activated, the GATE is immediately turned off and then slowly turned back on for a single retry.

The IS+, IS-, and IS_{OUT} pins combine to provide a load current monitor feature that presents a scaled version of the load current at the IS_{OUT} pin. Current to voltage conversion is accomplished by placing a resistor (R9) from IS_{OUT} to the negative input (-48V).

Applications

- VoIP (Voice over Internet Protocol) Servers
- Telecom systems at -48V
- Negative Power Supply Control
- +24V Wireless Base Station Power

Related Literature

- ISL6140/50EVAL1 Board Set, Document [AN9967](#)
- ISL6141/51 Hot Plug Controller, Document [FN9079](#)
- ISL6140/50 Hot Plug Controller, Document [FN9039](#)
- ISL6116 Hot Plug Controller, Document [FN9100](#)

NOTE: See www.intersil.com/hotplug for more information.

Pinout

ISL6142 OR ISL6152 (14 LEAD SOIC)

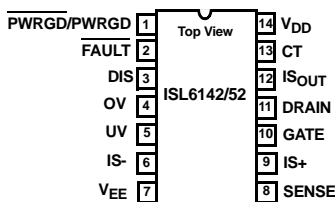

Features

- Operates from -18V to -80V (-100V Absolute Max Rating)
- Programmable Inrush Current
- Programmable Time-Out
- Programmable Current Limit
- Programmable Over-Voltage Protection
- Programmable Under-Voltage Protection
 - 135 mV of hysteresis ~4.7V of hysteresis at the power supply
- V_{DD} Under-Voltage Lock-Out (UVLO) ~ 16.5V
- IntelliTrip™ Electronic Circuit Breaker distinguishes between severe and moderate faults
 - Fast shutdown for short circuit faults with a single retry (fault current > 4X current limit value).
- FAULT pin reports the occurrence of an Over-Current Time-Out
- Disable input controls GATE shutdown and resets Over-Current fault latch
- Load Current Monitor Function
 - IS_{OUT} provides a scaled version of the load current
 - A resistor from IS_{OUT} to -V_{IN} provides current to voltage conversion
- Power Good Control Output
 - Output latched “good” when DRAIN and GATE voltage thresholds are met.
 - (PWRGD active low: ISL6142 (L version)
 - PWRGD active high: ISL6152 (H version)
- Pb-Free (RoHS Compliant)

Typical Application

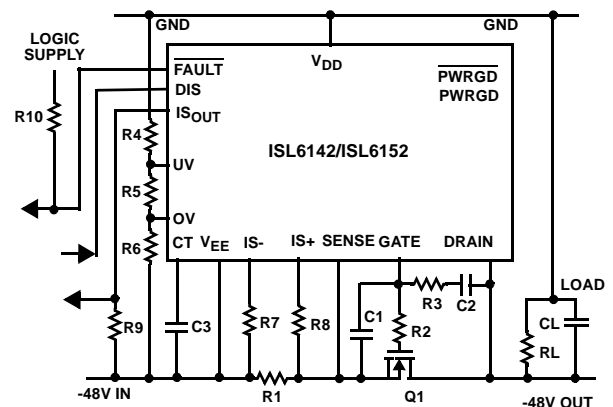

- | | | |
|------------------|---------------------|----------------------|
| R1 = 0.02Ω (1%) | R6 = 10kΩ (1%) | C2 = 3.3nF (100V) |
| R2 = 10Ω (5%) | R7 = R8 = 400Ω (1%) | C3 = 1500pF (25V) |
| R3 = 18kΩ (5%) | R9 = 4.99kΩ (1%) | Q1 = IRF530 |
| R4 = 549kΩ (1%) | R10 = 5.1kΩ (10%) | CL = 100μF (100V) |
| R5 = 6.49kΩ (1%) | C1 = 150nF (25V) | RL = Equivalent load |

Ordering Information

PART NUMBER (Notes 1, 2, 3)	TEMP. RANGE (°C)	PACKAGE (Pb-free)	PKG. DWG. #
ISL6142CBZA	0 to +70	14 Lead SOIC	M14.15
ISL6152CBZA	0 to +70	14 Lead SOIC	M14.15
ISL6142IBZA	-40 to +85	14 Lead SOIC	M14.15
ISL6152IBZA	-40 to +85	14 Lead SOIC	M14.15
ISL6142/52EVAL1	Evaluation Board		

NOTES:

1. Add “-T*” suffix for tape and reel. Please refer to [TB347](#) for details on reel specifications.
2. These Intersil Pb-free plastic packaged products employ special Pb-free material sets, molding compounds/die attach materials, and 100% matte tin plate plus anneal (e3 termination finish, which is RoHS compliant and compatible with both SnPb and Pb-free soldering operations). Intersil Pb-free products are MSL classified at Pb-free peak reflow temperatures that meet or exceed the Pb-free requirements of IPC/JEDEC J STD-020.
3. For Moisture Sensitivity Level (MSL), please see device information page for [ISL6142](#), [ISL6152](#). For more information on MSL, please see tech brief [TB363](#).

CONFIDENTIAL
IN REVIEW

ISL6142, ISL6152 Block Diagram

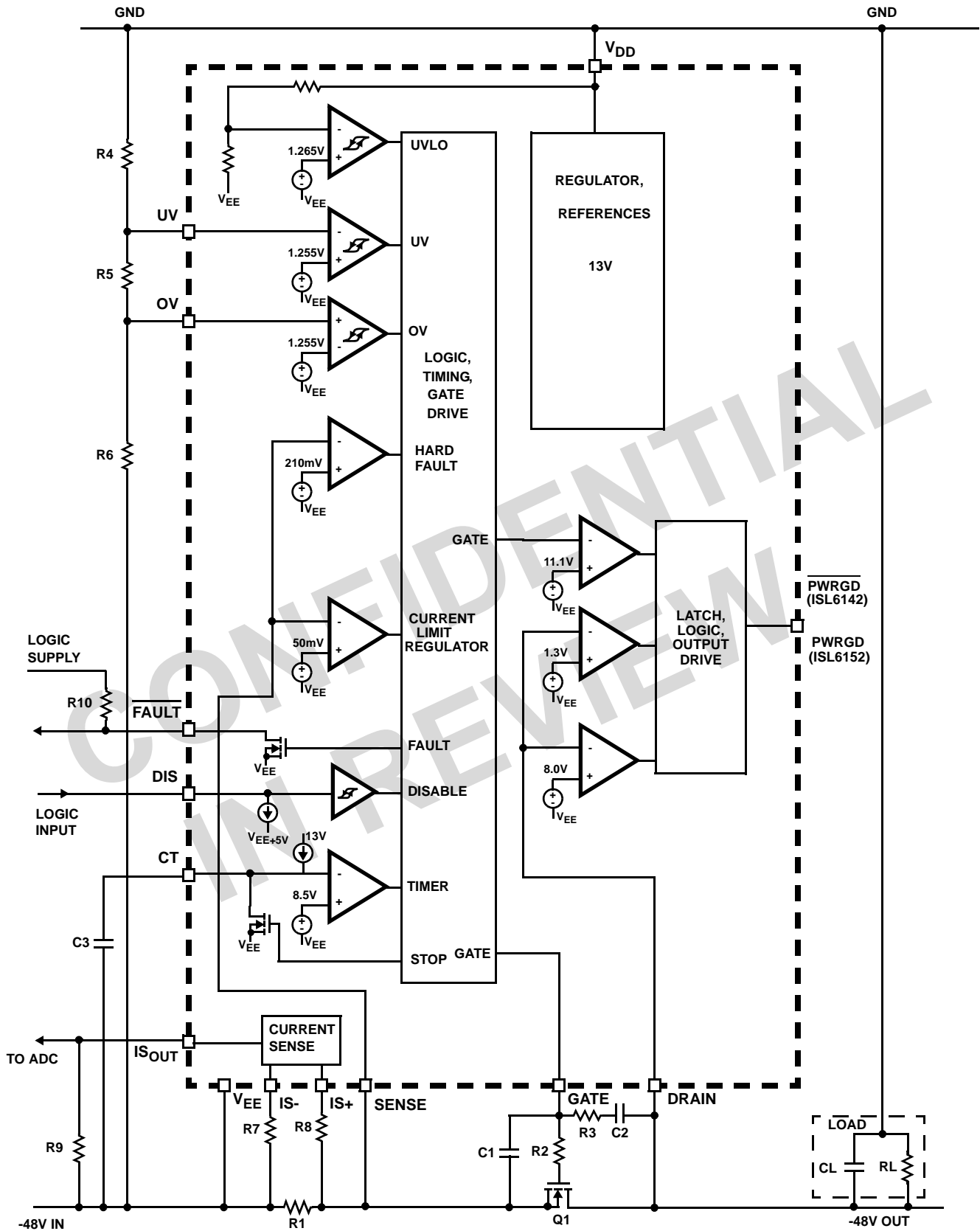

FIGURE 1. BLOCK DIAGRAM

Pin Descriptions

PWRGD (ISL6142; L Version) Pin 1 - This digital output is an open-drain pull-down device and can be used to directly enable an external module. During start-up the DRAIN and GATE voltages are monitored with two separate comparators. The first comparator looks at the DRAIN pin voltage compared to the internal V_{PG} reference (1.3V); this measures the voltage drop across the external FET and sense resistor. When the DRAIN to V_{EE} voltage drop is less than 1.3V, the first of two conditions required for the power to be considered good are met. In addition, the GATE voltage monitored by the second comparator must be within approximately 2.5V of its normal operating voltage (13.6V). When both criteria are met the $\overline{\text{PWRGD}}$ output will transition low and be latched in the active state, enabling the external module. When this occurs the two comparators discussed above no longer control the output. However a third comparator continues to monitor the DRAIN voltage, and will drive the $\overline{\text{PWRGD}}$ output inactive if the DRAIN voltage raises more than 8V above V_{EE} . In addition, any of the signals that shut off the GATE (Over-Voltage, Under-Voltage, Under-Voltage Lock-Out, Over-Current time-out, pulling the DIS pin high, or powering down) will reset the latch and drive the $\overline{\text{PWRGD}}$ output high to disable the module. In this case, the output pull-down device shuts off, and the pin becomes high impedance. Typically an external pull-up of some kind is used to pull the pin high (many brick regulators have a pull-up function built in).

PWRGD (ISL6152; H Version) Pin 1 - This digital output is used to provide an active high signal to enable an external module. The Power Good comparators are the same as described above, but the active state of the output is reversed (reference Figure 37).

When power is considered good (both DRAIN and GATE are normal) the output is latched in the active high state, the DMOS device (Q3) turns on and sinks current to V_{EE} through a 6.2k Ω resistor. The base of Q2 is clamped to V_{EE} to turn it off. If the external pull-up current is high enough (>1mA, for example), the voltage drop across the resistor will be large enough to produce a logic high output and enable the external module (in this example, 1mA x 6.2k Ω = 6.2V).

Note that for all H versions, although this is a digital pin functionally, the logic high level is determined by the external pull-up device, and the power supply to which it is connected; the IC will not clamp it below the V_{DD} voltage. Therefore, if the external device does not have its own clamp, or if it would be damaged by a high voltage, an external clamp might be necessary.

If the power good latch is reset (GATE turns off), the internal DMOS device (Q3) is turned off, and Q2 (NPN) turns on to clamp the output one diode drop above the DRAIN voltage to produce a logic low, indicating power is no longer good.

FAULT Pin 2 - This digital output is an open-drain, pull-down device, referenced to V_{EE} . It is pulled active low whenever the Over-Current latch is set. It goes to a high impedance state when the fault latch is reset by toggling the UV or DIS pins. An external pull-up resistor to a logic supply (5V or less) is required; the fault outputs of multiple IC's can be wire-OR'd together. If the pin is not used it should be left open.

DIS Pin 3 - This digital input disables the FET when driven to a logic high state. It has a weak internal pull-up device to an internal 5V rail (10 μ A), so an open pin will also act as a logic high. The input has a nominal trip point of 1.6V while rising, and a hysteresis of 1.0V. The threshold voltage is referenced to V_{EE} , and is compatible with CMOS logic levels. A logic low will allow the GATE to turn on (assuming the 4 other conditions described in the GATE section are also true). The DIS pin can also be used to reset the Over-Current latch when toggled high to low. If not used the pin should be tied to the negative supply rail ($-V_{IN}$).

OV (Over-Voltage) Pin 4 - This analog input compares the voltage on the pin to an internal voltage reference of 1.255V (nominal). When the input goes above the reference the GATE pin is immediately pulled low to shut off the external FET. The built in 25mV hysteresis will keep the GATE off until the OV pin drops below 1.230V (the nominal high to low threshold). A typical application will use an external resistor divider from V_{DD} to $-V_{IN}$ to set the OV trip level. A three-resistor divider can be used to set both OV and UV trip points to reduce component count.

UV (Under-Voltage) Pin 5 - This analog input compares the voltage on the pin to an internal comparator with a built in hysteresis of 135mV. When the UV input goes below the nominal reference voltage of 1.120V, the GATE pin is immediately pulled low to shut off the external FET. The GATE will remain off until the UV pin rises above a 1.255V low to high threshold. A typical application will use an external resistor divider from V_{DD} to $-V_{IN}$ to set the UV level as desired. A three-resistor divider can be used to set both OV and UV trip points to reduce component count.

The UV pin is also used to reset the Over-Current latch. The pin must be cycled below 1.120V (nominal) and then above 1.255V (nominal) to clear the latch and initiate a normal start-up sequence.

IS- Pin 6 - This analog pin is the negative input of the current sense circuit. A sensing resistor (R7) is connected between this pin and the V_{EE} side of resistor R1. The ratio of R1/R7 defines the I_{SENSE} to I_{SOUT} current scaling factor. If current sensing is not used in the application, the IS- pin should be tied directly to the IS+ pin and the node should be left floating.

V_{EE} Pin 7 - This is the most Negative Supply Voltage, such as in a -48V system. Most of the other signals are referenced relative to this pin, even though it may be far away from what is considered a GND reference.

SENSE Pin 8 - This analog input monitors the voltage drop across the external sense resistor to determine if the current flowing through it exceeds the programmed Over-Current trip point (50mV/R_{sense}). If the Over-Current threshold is exceeded, the circuit will regulate the current to maintain a nominal voltage drop of 50mV across the R1 sense resistor, also referred to as R_{sense}. If current is limited for more than the programmed time-out period the IntelliTrip™ electronic circuit breaker will trip and turn off the FET.

A second comparator is employed to detect and respond quickly to hard faults. The threshold of this comparator is set approximately four times higher (210mV) than the Over-Current trip point. When the hard fault comparator threshold is exceeded the GATE is immediately (10µs typical) shut off (V_{GATE} = V_{EE}), the timer is reset, and a single retry (soft-start) is initiated.

IS+ Pin 9 - This analog pin is the positive input of the current sense circuit. A sensing resistor (R8) is connected between this pin and the output side of R1, which is also connected to the SENSE pin. It should match the IS- resistor (R7) as closely as possible (1%) to minimize output current error (I_{SOUT}). If current sensing is not used in the application, the IS+ pin should be tied directly to the IS- pin and the node should be left floating.

GATE Pin 10 - This analog output drives the gate of the external FET used as a pass transistor. The GATE pin is high (FET is on) when the following conditions are met:

- V_{DD} UVLO is above its trip point (~16.5V)
- Voltage on the UV pin is above its trip point (1.255V)
- Voltage on the OV pin is below its trip point (1.255V)
- No Over-Current conditions are present.
- The Disable pin is low.

If any of the 5 conditions are violated, the GATE pin will be pulled low to shut off or regulate current through the FET. The GATE is latched off only when an Over-Current event exceeds the programmed time-out period.

The GATE is driven high by a weak (-50µA nominal) pull-up current source, in order to slowly turn on the FET. It is driven low by a 70mA (nominal) pull-down device for three of the above shut-off conditions. A larger (350mA nominal) pull-down current shuts off the FET very quickly in the event of a hard fault where the sense pin voltage exceeds approximately 210mV.

DRAIN Pin 11 - This analog input monitors the voltage of the FET drain for the Power Good function. The DRAIN input is tied to two comparators with internal reference voltages of

1.3V and 8.0V. At initial start-up the DRAIN to V_{EE} voltage differential must be less than 1.3V, and the GATE voltage must be within 2.5V of its normal operating voltage (13.6V) for power to be considered good. When both conditions are met, the PWRGD/PWRGD output is latched into the active state. At this point only the 8V DRAIN comparator can control the PWRGD/PWRGD output, and will drive it inactive if the DRAIN voltage exceeds V_{EE} by more than 8.0V.

IS_{OUT} Pin 12 - This analog pin is the output of the current sense circuit. The current flowing out of this pin (I_{SOUT}) is proportional to the current flowing through the R1 sense resistor (I_{SENSE}). The scaling factor, I_{SOUT}/I_{SENSE} is defined by the resistor ratio of R1/R7. Current to voltage conversion is accomplished by placing a resistor from this pin to -V_{IN}. The current flowing out of the pin is supplied by the internal 13V regulator and should not exceed 600µA. The output voltage will clamp at approximately 8V. If current sensing is not used in the application the pin should be left open.

CT Pin 13 - This analog I/O pin is used to program the Over-Current Time-Out period with a capacitor connected to the negative supply rail (-V_{IN} which is equal to V_{EE}). During normal operation, the pin is pulled down to V_{EE}. During current limiting, the capacitor is charged with a 20µA (nominal) current source. When the CT pin charges to 8.5V, it times out and the GATE is latched off. If the short circuit goes away prior to the time-out, the GATE will remain on. If no capacitor is connected, the time-out will be much quicker, with only the package pin capacitance (~ 5 to 10pF) to charge. If no external capacitor is connected to the CT pin the time-out will occur in a few µsec. To set the desired time-out period use:

$$dt = (C * dV)/I = (C * 8.5)/20 \mu A = 0.425 * 10^6 * C$$

NOTE: The printed circuit board's parasitic capacitance (CT pin to the negative input, -V_{IN}) should be taken into consideration when calculating the value of C3 needed for the desired time-out.

V_{DD} Pin 14 - This is the most positive Power Supply pin. It can range from the Under-Voltage lockout threshold (typically 16.5V) to +80V (Relative to V_{EE}). The pin can tolerate up to 100V without damage to the IC.

ISL6142, ISL6152

Absolute Maximum Ratings

Supply Voltage (V_{DD} to V_{EE})	-0.3V to 100V
DRAIN, PWRGD, PWRGD Voltage	-0.3V to 100V
UV, OV Input Voltage	-0.3V to 60V
SENSE, GATE Voltage	-0.3V to 20V
FAULT, DIS, IS+, IS-, ISOUT, CT	-0.3V to 8.0V
ESD Rating	Human Body Model (Per MIL-STD-883 Method 3015.7) . . .2000V

Thermal Information

Thermal Resistance (Typical, Note 4)	θ_{JA} ($^{\circ}\text{C}/\text{W}$)
14 Lead SOIC	70
Maximum Junction Temperature (Plastic Package)	+150 $^{\circ}\text{C}$
Maximum Storage Temperature Range	-65 $^{\circ}\text{C}$ to +150 $^{\circ}\text{C}$
Maximum Lead Temperature (Soldering 10s)	+300 $^{\circ}\text{C}$

Operating Conditions

Temperature Range (Industrial)	-40 $^{\circ}\text{C}$ to +85 $^{\circ}\text{C}$
Temperature Range (Commercial)	0 $^{\circ}\text{C}$ to +70 $^{\circ}\text{C}$
Supply Voltage Range (Typical)	36V to 72V

CAUTION: Stresses above those listed in "Absolute Maximum Ratings" may cause permanent damage to the device. This is a stress only rating and operation of the device at these or any other conditions above those indicated in the operational sections of this specification is not implied.

NOTES:

- θ_{JA} is measured with the component mounted on a high effective thermal conductivity test board in free air. See Tech Brief TB379 for details.
- PWRGD is referenced to DRAIN; $V_{PWRGD} - V_{DRAIN} = 0\text{V}$.

Electrical Specifications

$V_{DD} = +48\text{V}$, $V_{EE} = +0\text{V}$ Unless Otherwise Specified. All tests are over the full temperature range; either Commercial (0 $^{\circ}\text{C}$ to +70 $^{\circ}\text{C}$) or Industrial (-40 $^{\circ}\text{C}$ to +85 $^{\circ}\text{C}$). Typical specs are at +25 $^{\circ}\text{C}$.

PARAMETER	SYMBOL	TEST CONDITIONS	MIN	TYP	MAX	UNITS
DC PARAMETRIC						
V_{DD} PIN						
Supply Operating Range	V_{DD}		18		80	V
Supply Current	I_{DD}	UV = 3V; OV = V_{EE} ; SENSE = V_{EE} ; $V_{DD} = 80\text{V}$		2.6	4.0	mA
UVLO High	V_{UVLOH}	V_{DD} Low to High transition	15	16.7	17.9	V
UVLO Low	V_{UVLOL}	V_{DD} High to Low transition	13	15.0	17	V
UVLO Hysteresis				1.9		V
GATE PIN						
GATE Pin Pull-Up Current	I_{PU}	GATE Drive on, $V_{GATE} = V_{EE}$	-30	-50	-60	μA
GATE Pin Pull-Down Current	I_{PD1}	GATE Drive off, UV or OV false		70		mA
GATE Pin Pull-Down Current	I_{PD2}	GATE Drive off, Over-Current Time-Out		70		mA
GATE Pin Pull-Down Current	I_{PD3}	GATE Drive off; Hard Fault, $V_{sense} > 210\text{mV}$		350		mA
External Gate Drive (at 18V, at 80V)	ΔV_{GATE}	$(V_{GATE} - V_{EE})$, $18\text{V} \leq V_{DD} \leq 80\text{V}$	12	13.6	15	V
GATE High Threshold (PWRGD/PWRGD active)	V_{GH}	$\Delta V_{GATE} - V_{GATE}$		2.5		V
SENSE PIN						
Current Limit Trip Voltage	V_{CL}	$V_{CL} = (V_{SENSE} - V_{EE})$	40	50	60	mV
Hard Fault Trip Voltage	HFTV	$HFTV = (V_{SENSE} - V_{EE})$		210		mV
SENSE Pin Current	I_{SENSE}	$V_{SENSE} = 50\text{mV}$		0	-0.5	μA
UV PIN						
UV Pin High Threshold Voltage	V_{UVH}	UV Low to High Transition	1.240	1.255	1.270	V
UV Pin Low Threshold Voltage	V_{UVL}	UV High to Low Transition	1.105	1.120	1.145	V
UV Pin Hysteresis	V_{UVHY}			135		mV
UV Pin Input Current	I_{INUV}	$V_{UV} = V_{EE}$	-	-0.05	-0.5	μA

ISL6142, ISL6152

Electrical Specifications $V_{DD} = +48V$, $V_{EE} = +0V$ Unless Otherwise Specified. All tests are over the full temperature range; either Commercial (0°C to +70°C) or Industrial (-40°C to +85°C). Typical specs are at +25°C. **(Continued)**

PARAMETER	SYMBOL	TEST CONDITIONS	MIN	TYP	MAX	UNITS
OV PIN						
OV Pin High Threshold Voltage	V_{OVH}	OV Low to High Transition	1.235	1.255	1.275	V
OV Pin Low Threshold Voltage	V_{OVL}	OV High to Low Transition	1.215	1.230	1.255	V
OV Pin Hysteresis	V_{OVHY}			25		mV
OV Pin Input Current	I_{INOV}	$V_{OV} = V_{EE}$		-0.05	-0.5	μA
DRAIN PIN						
Power Good Threshold (Enable \overline{PWRGD} /PWRGD Output)	V_{PG}	$V_{DRAIN} - V_{EE}$	0.80	1.30	2.00	V
Drain Input Bias Current	I_{DRAIN}	$V_{DRAIN} = 48V$	10	38	60	μA
DRAIN Pin Comparator Trip Point (PWRGD/PWRGD Inactive)	V_{DH}	$V_{DRAIN} - V_{EE} > 8.0V$	7.0	8.0V	9.0	V
ISL6142 (PWRGD Pin: L Version)						
\overline{PWRGD} Output Low Voltage	V_{OL1}	$(V_{DRAIN} - V_{EE}) < V_{PG}$; $I_{OUT} = 1mA$		0.3	0.8	V
	V_{OL5}	$(V_{DRAIN} - V_{EE}) < V_{PG}$; $I_{OUT} = 5mA$		1.50	3.0	V
Output Leakage	I_{OH}	$V_{DRAIN} = 48V$, $V_{\overline{PWRGD}} = 80V$		0.05	10	μA
ISL6152 (PWRGD Pin: H Version)						
PWRGD Output Low Voltage (PWRGD-DRAIN)	V_{OL}	$V_{DRAIN} = 5V$, $I_{OUT} = 1mA$		0.80	1.0	V
PWRGD Output Impedance	R_{OUT}	$(V_{DRAIN} - V_{EE}) < V_{PG}$	4.5	6.2	7.5	k Ω
DIS PIN						
DIS Pin High Threshold Voltage	V_{DISH}	DIS Low to High Transition	1.60	2.20	3.00	V
DIS Pin Low Threshold Voltage	V_{DISL}	DIS High to Low Transition		1.1	1.50	V
DIS Pin Hysteresis	V_{DISHY}	DIS Hysteresis		1.0		V
DIS Pin Input High Leakage	I_{DISINH}	Input Voltage = 5V		0.1	1.0	μA
DIS Pin Input Low Current	I_{DISINL}	Input Voltage = 0V		10		μA
FAULT PIN						
\overline{FAULT} Output Voltage	V_{FVOL}	$I = 1.6mA$		0.4		V
\overline{FAULT} Output Leakage	I_{FIOH}	$V = 5.0V$			10	μA
CT PIN						
CT Pin Charging Current	I_{CTINL}	$V_{CT} = 0V$		20		μA
CT Pin Input Threshold	V_{CT}		7.5	8.5	9.5	V
IS PINS (IS-, IS+, IS_{OUT})						
IS _{OUT} Error		$V_{SENSE} = 50mV$, $R7 = 400\Omega$, $R8 = 404\Omega$		2.0		%
IS _{OUT} Error		$V_{SENSE} = 200mV$, $R7 = 400\Omega$, $R8 = 404\Omega$		1.0		%
IS _{OUT} Offset Current		$V_{SENSE} = 0.0mV$, $R7 = 400\Omega$, $R8 = 404\Omega$		4.5		μA
Output Voltage Range (IS _{OUT} Pin)			0	5	8	V
AC TIMING						
OV High to GATE Low	t_{PHLOV}	Figures 2A, 3A	0.6	1.6	3.0	μs
OV Low to GATE High	t_{PLHOV}	Figures 2A, 3A	1.0	7.8	12.0	μs
UV Low to GATE Low	t_{PHLUV}	Figures 2A, 3B	0.6	1.3	3.0	μs

ISL6142, ISL6152

Electrical Specifications $V_{DD} = +48V$, $V_{EE} = +0V$ Unless Otherwise Specified. All tests are over the full temperature range; either Commercial (0°C to +70°C) or Industrial (-40°C to +85°C). Typical specs are at +25°C. **(Continued)**

PARAMETER	SYMBOL	TEST CONDITIONS	MIN	TYP	MAX	UNITS
UV High to GATE High	t_{PLHUV}	Figures 2A, 3B	1.0	8.4	12.0	μs
DIS Low to GATE Low	t_{PHLDIS}	Figure 2A, 7		0.6		μs
DIS High to GATE High	t_{PLHDIS}	Figure 2A, 7		2.5		μs
GATE Low (Over-Current) to \overline{FAULT} Low	t_{PHLGF}	Figure 2A, 8		0.5		μs
IS _{OUT} Rise Time	t_R	Figure 2A, 12		1.2		μs
IS _{OUT} Fall Time	t_F	Figure 2A, 12		4.0		μs
SENSE High to GATE Low	$t_{PHLSENSE}$	Figures 2A, 9		1	3	μs
Current Limit to GATE Low	t_{PHLCB}	Figures 2B, 11, Effective Capacitance During Test = 2550pF		1200		μs
Hard Fault to GATE Low (200mV comparator) Typical GATE shutdown based on application ckt. Guaranteed by design.	t_{PHLHF}	Figures 10, 20, 33		10.0		μs
ISL6142 (L Version)						
DRAIN Low to \overline{PWRGD} Low (Active)	t_{PHLDL}	Figures 2A, 4A	0.1	3.1	5.0	μs
DRAIN High to \overline{PWRGD} High (Inactive)	t_{PLHDH}	Figure 2A, 6A		0.2		μs
GATE High to \overline{PWRGD} Low (Active)	t_{PHLGH}	Figures 2A, 5A		1.0		μs
ISL6152 (H Version)						
DRAIN Low to (PWRGD-DRAIN) High (Active)	t_{PHLDL}	Figures 2A, 4B	0.1	0.2	5.0	μs
DRAIN High to (PWRGD -DRAIN) Low (Inactive)	t_{PHLDH}	Figure 2A, 6B		0.5		μs
GATE High to (PWRGD-DRAIN) High (Active)	t_{PLHGH}	Figures 2A, 5B		0.4		μs

Test Circuit and Timing Diagrams

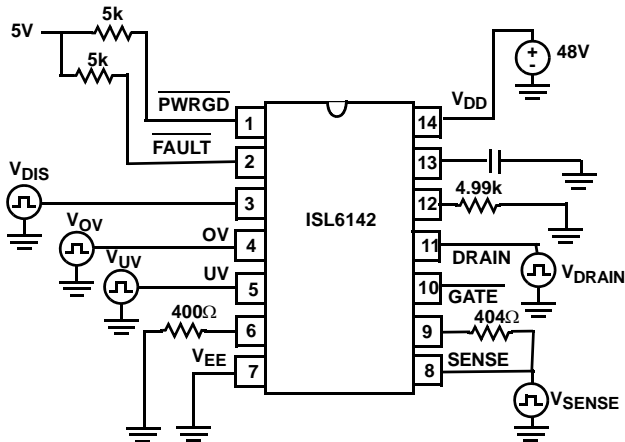

FIGURE 2A. TYPICAL TEST CIRCUIT

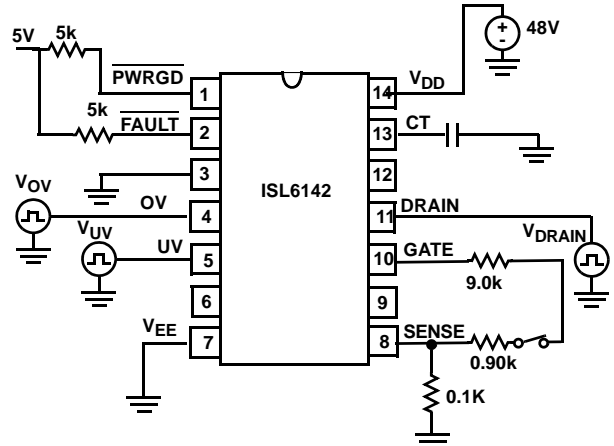

FIGURE 2B. TEST CIRCUIT FOR TIMEOUT



FIGURE 3A. OV TO GATE TIMING

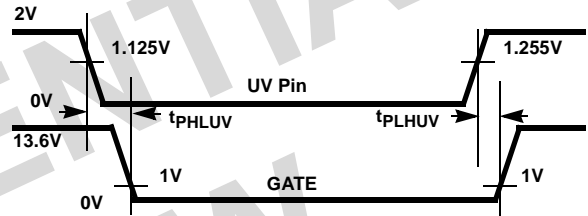

FIGURE 3B. UV TO GATE TIMING

FIGURE 3. OV AND UV TO GATE TIMING

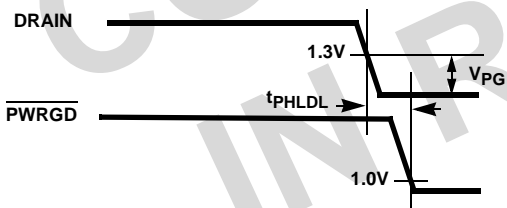

FIGURE 4A. DRAIN TO $\overline{\text{PWRGD}}$ ACTIVE TIMING (ISL6142)

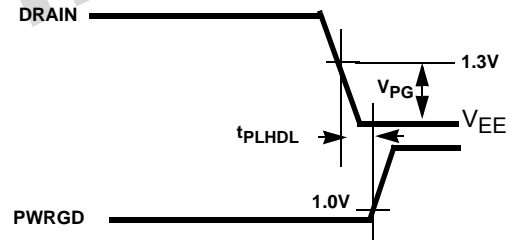

FIGURE 4B. DRAIN TO $\overline{\text{PWRGD}}$ ACTIVE TIMING (ISL6152)

FIGURE 4. DRAIN TO $\overline{\text{PWRGD}}$ /PWRGD TIMING

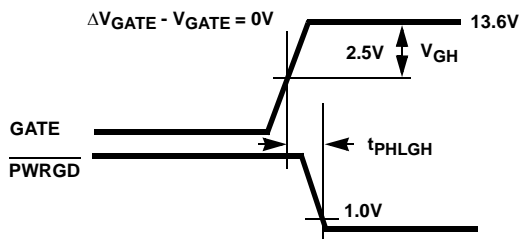

FIGURE 5A. GATE TO $\overline{\text{PWRGD}}$ ACTIVE (ISL6142)

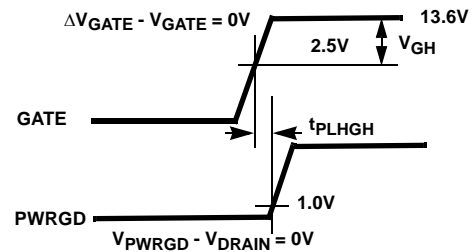

FIGURE 5B. GATE TO $\overline{\text{PWRGD}}$ ACTIVE (ISL6152)

Test Circuit and Timing Diagrams (Continued)

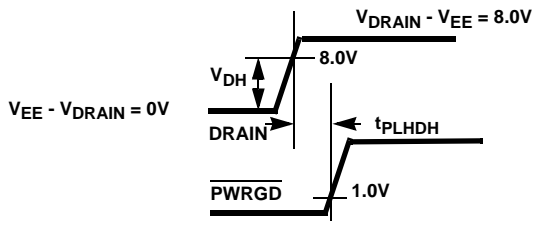

FIGURE 6A. DRAIN HIGH TO $\overline{\text{PWRGD}}$ (INACTIVE) HIGH (ISL6142)

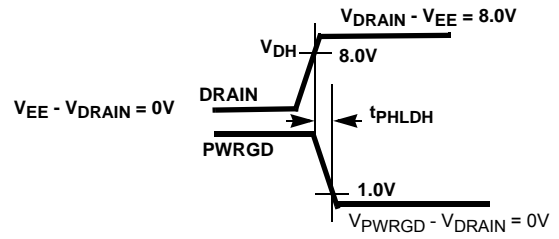

FIGURE 6B. DRAIN HIGH TO $\overline{\text{PWRGD}}$ (INACTIVE) LOW (ISL6152)

FIGURE 6. DRAIN TO $\overline{\text{PWRGD}}$ / $\overline{\text{PWRGD}}$ INACTIVE TIMING

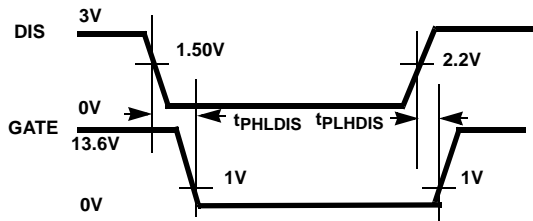

FIGURE 7. DISABLE TO GATE TIMING (ISL6142/52)

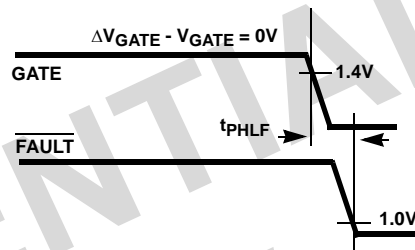

FIGURE 8. FAULT TO GATE TIMING (ISL6142/52)

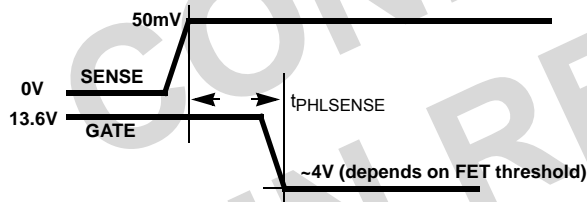

FIGURE 9. SENSE TO GATE (CURRENT LIMIT) TIMING

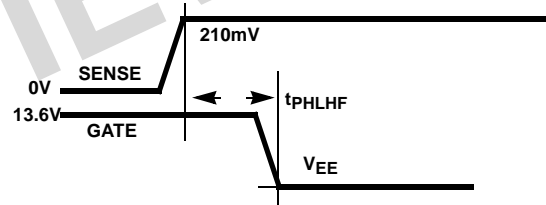
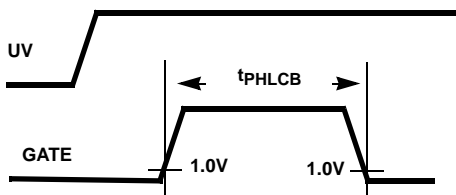

FIGURE 10. SENSE TO GATE (HARD FAULT) TIMING



Over-Current Time-Out

FIGURE 11. CURRENT LIMIT TO GATE TIMING

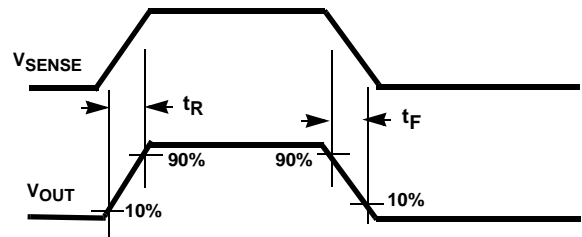

FIGURE 12. OUTPUT CURRENT RISE AND FALL TIME

Typical Performance Curves

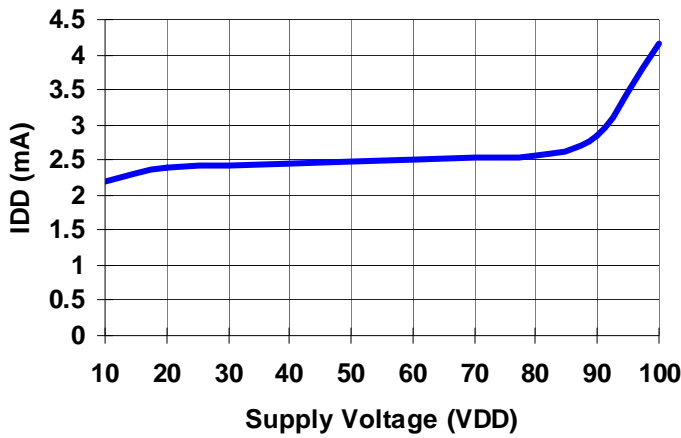

FIGURE 13. SUPPLY CURRENT VS. SUPPLY VOLTAGE (25°C)

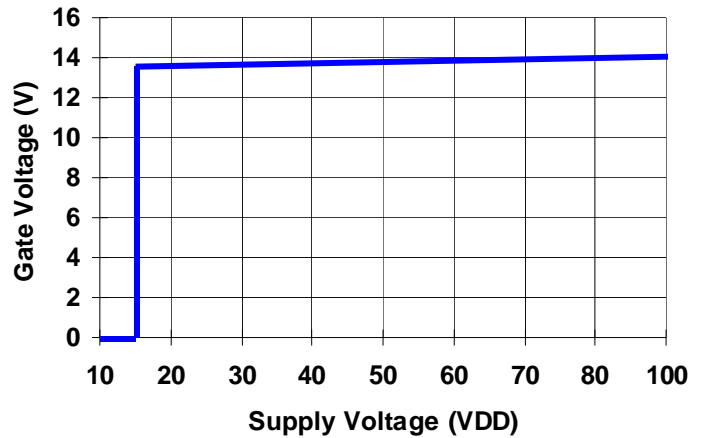

FIGURE 14. GATE VOLTAGE VS SUPPLY VOLTAGE (25°C)

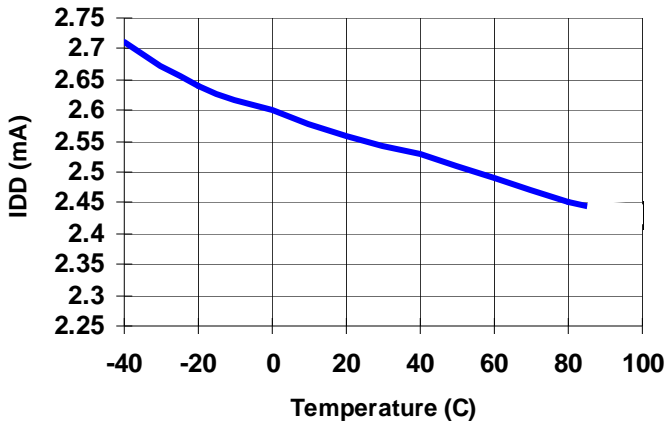

FIGURE 15. SUPPLY CURRENT VS TEMPERATURE, $V_{DD} = 80V$

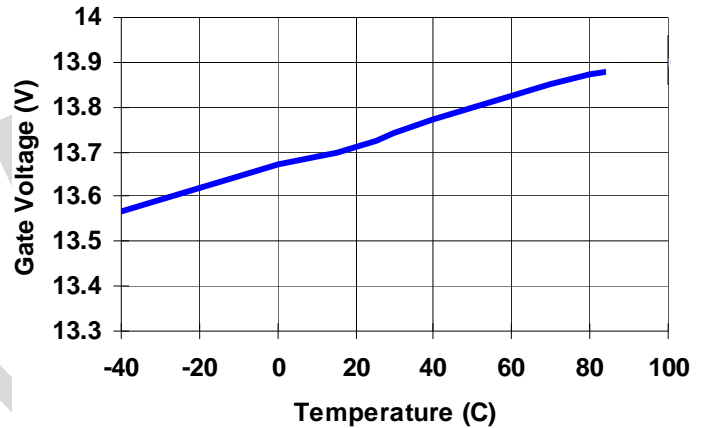

FIGURE 16. GATE VOLTAGE VS TEMPERATURE $V_{DD} = 48V$

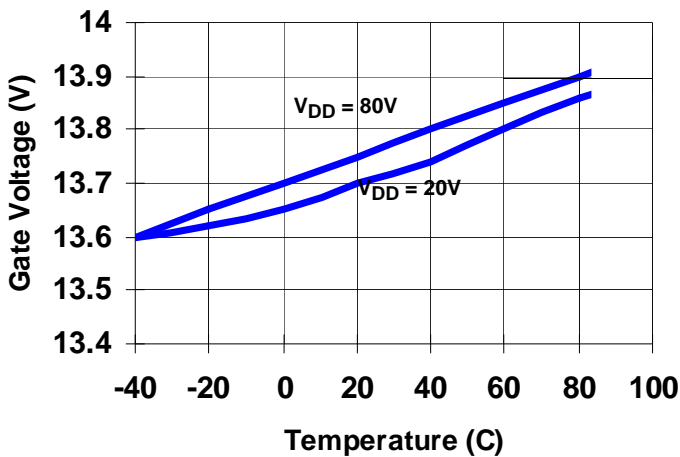

FIGURE 17. GATE VOLTAGE VS TEMPERATURE

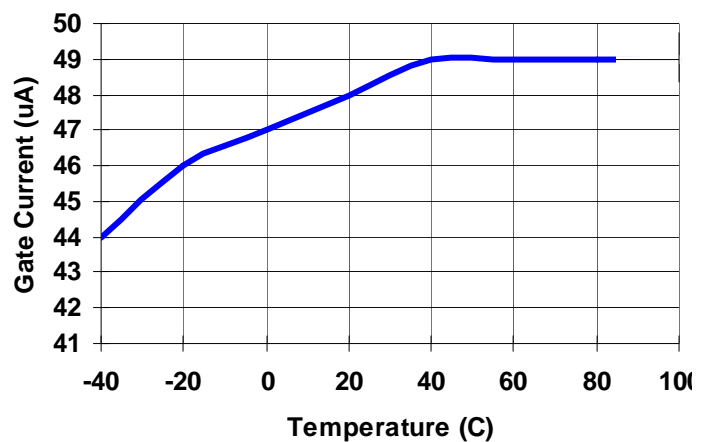

FIGURE 18. GATE PULL-UP CURRENT VS TEMPERATURE

Typical Performance Curves (Continued)

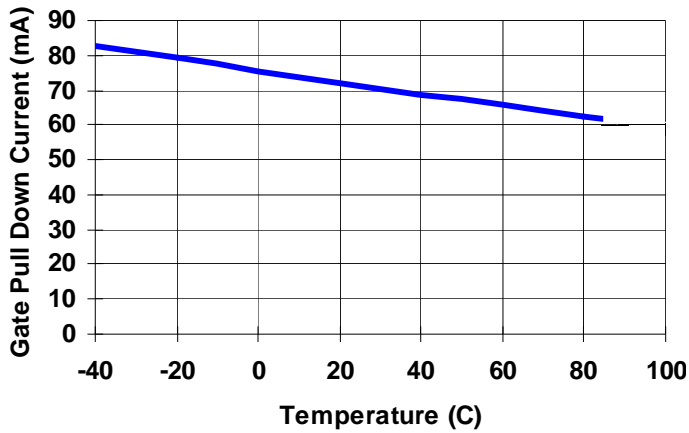

FIGURE 19. GATE PULL-DOWN CURRENT (UV/OV/TIME-OUT) VS TEMPERATURE

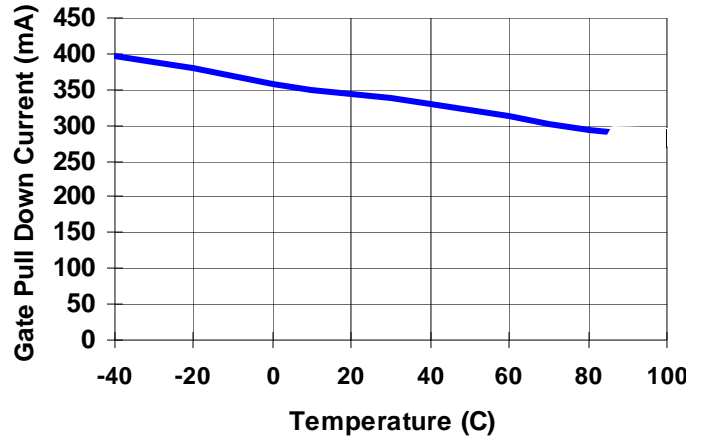

FIGURE 20. HARD FAULT GATE PULL-DOWN CURRENT VS TEMPERATURE

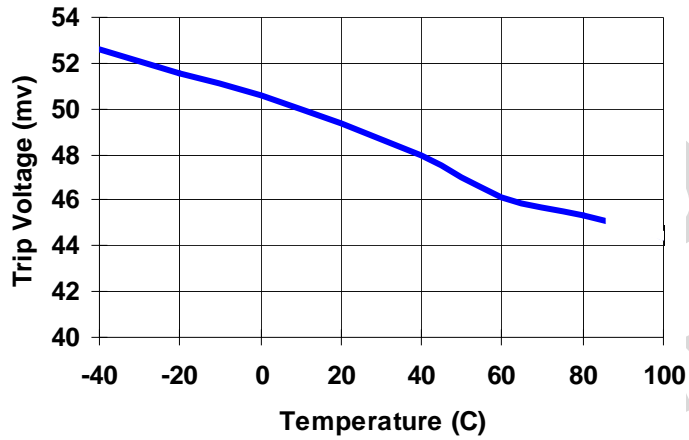

FIGURE 21. OVER-CURRENT TRIP VOLTAGE VS TEMPERATURE

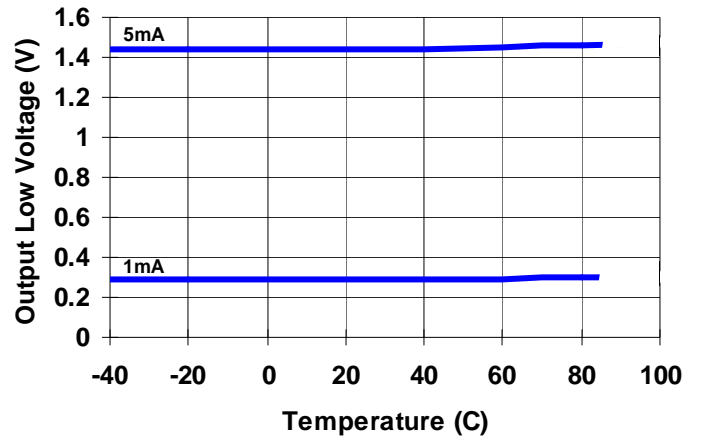

FIGURE 22. PWRGD (ISL6142) VOL VS TEMPERATURE

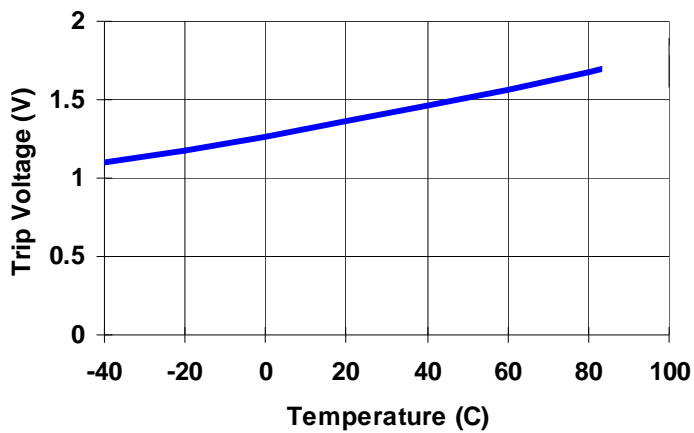

FIGURE 23. DRAIN TO PWRGD/PWRGD TRIP VOLTAGE (V_{PG}) VS TEMPERATURE

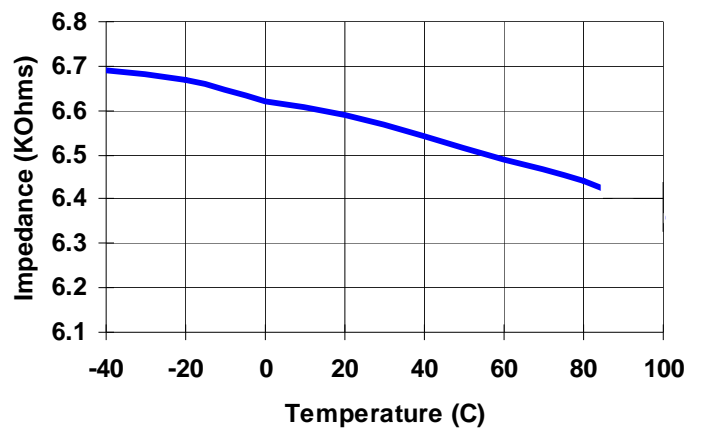

FIGURE 24. PWRGD (ISL6152) OUTPUT IMPEDANCE VS TEMPERATURE

Typical Performance Curves (Continued)

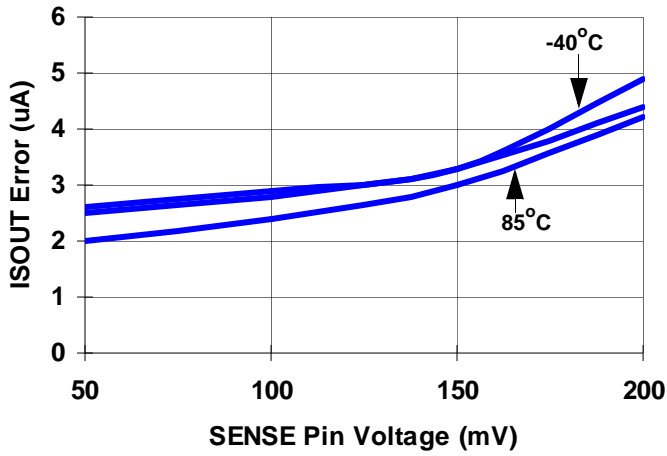

FIGURE 25. IS_{OUT} ERROR VS SENSE PIN VOLTAGE

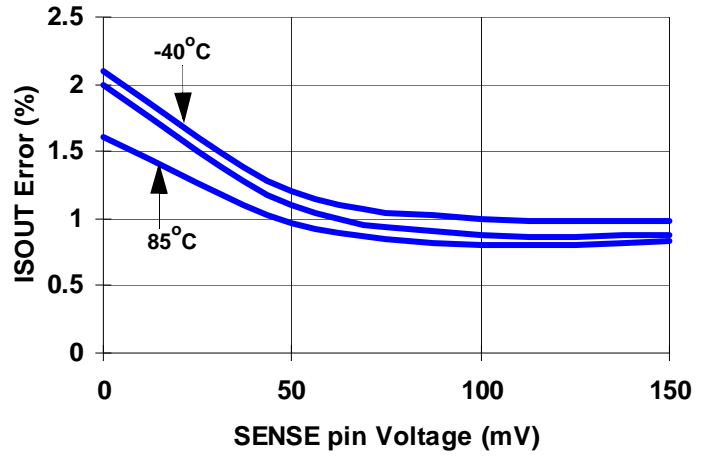

FIGURE 26. IS_{OUT} ERROR VS SENSE PIN VOLTAGE

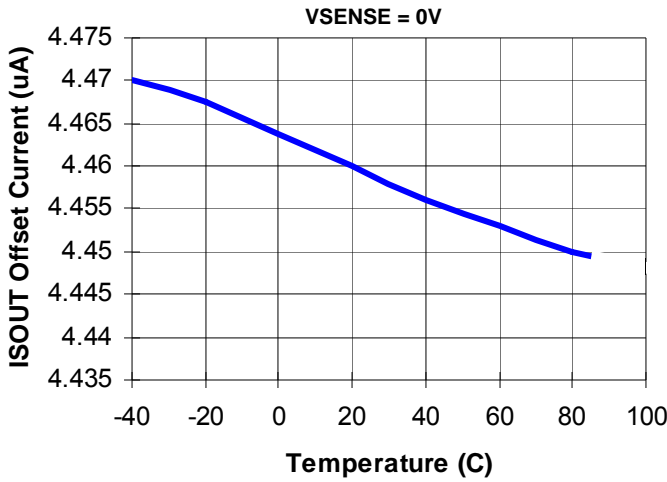

FIGURE 27. IS_{OUT} OFFSET CURRENT VS TEMPERATURE

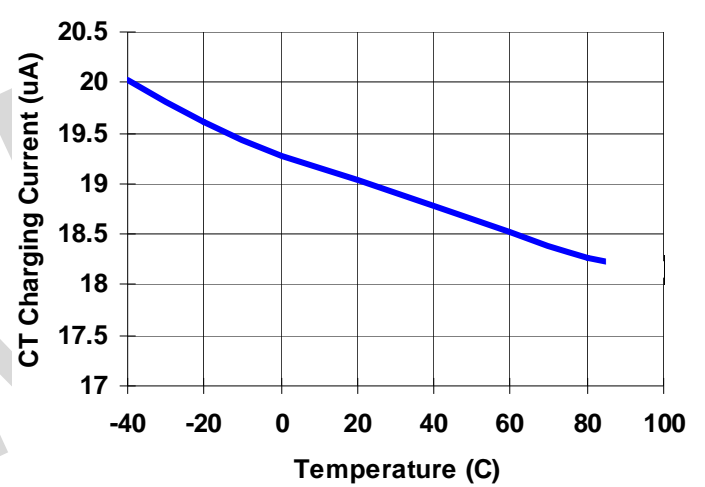

FIGURE 28. CT CHARGING CURRENT VS TEMPERATURE

Applications Information

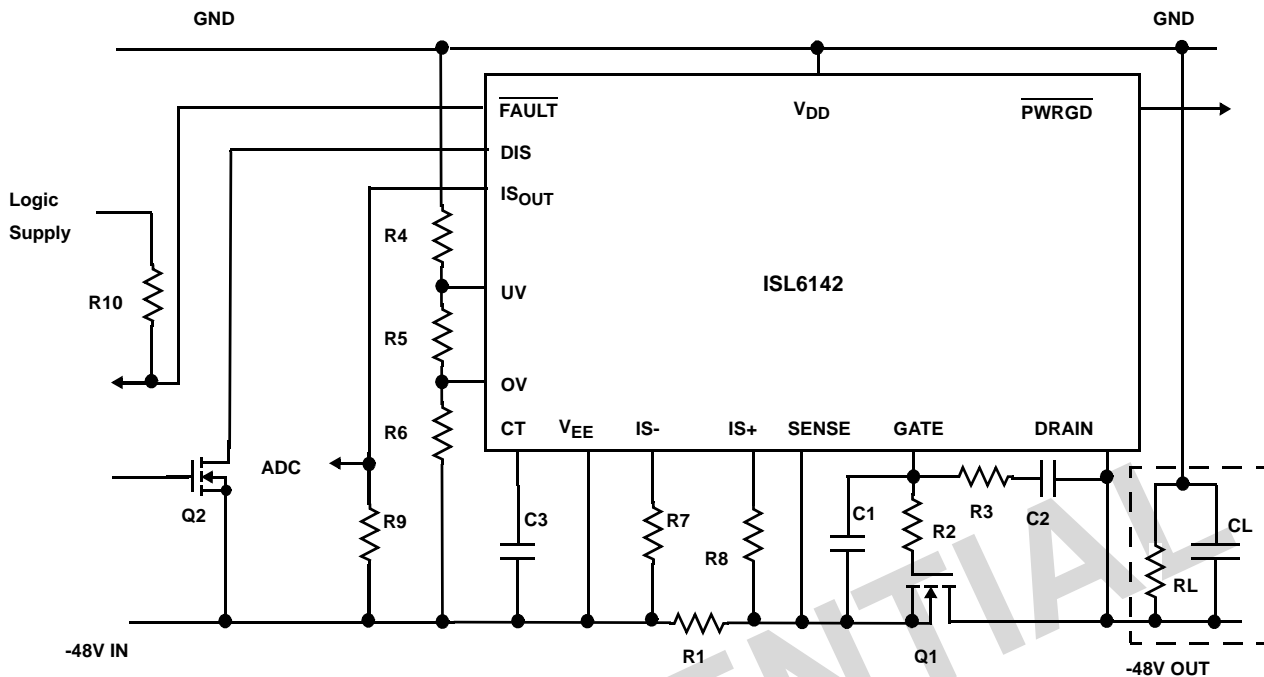

FIGURE 29. TYPICAL APPLICATION WITH MINIMUM COMPONENTS

Typical Values for a Representative System; which Assumes:

43V to 71V supply range; 48 nominal; UV = 43V; OV = 71V

1A of typical current draw; 2.5 Amp Over-Current

100 μ F of load capacitance (CL); equivalent RL of 48 Ω
($R = V/I = 48V/1A$)

R1: 0.02 Ω (1%)

R2: 10 Ω (5%)

R3: 18k Ω (5%)

R4: 549k Ω (1%)

R5: 6.49k Ω (1%)

R6: 10k Ω (1%)

R7/R8: 400 Ω (1%)

R9: 4.99k Ω (1%)

R10: 5.10k Ω (10%)

C1: 150nF (25V)

C2: 3.3nF (100V)

C3: 1500pF (25V)

Q1: IRF530 (100V, 17A, 0.11 Ω)

Q2: N-Channel logic FET

Quick Guide to Choosing Component Values

(See Figure 29 for reference)

This section will describe the minimum components needed for a typical application, and will show how to select component values. Note that “typical” values may only be good for this application; the user may have to select alternate component values to optimize performance for other applications. Each block will then have more detailed explanation of how the device works, and alternatives.

R4, R5, R6 - together set the Under-Voltage (UV) and Over-Voltage (OV) trip points. When the power supply ramps up and down, these trip points (and their hysteresis) will determine when the GATE is allowed to turn on and off (UV and OV do not control the PWRGD/PWRGD output). The input power supply is divided down such that when the voltage on the OV pin is below its threshold and the UV pin is above its threshold their comparator outputs will be in the proper state signaling the supply is within its desired operating range, allowing the GATE to turn on. The equations below define the comparator thresholds for an increasing (in magnitude) supply voltage.

$$V_{UV} = \frac{(R_4 + R_5 + R_6)}{(R_5 + R_6)} \times 1.255 \quad (\text{EQ. 1})$$

$$V_{OV} = \frac{(R_4 + R_5 + R_6)}{(R_6)} \times 1.255 \quad (\text{EQ. 2})$$

The values of R4 = 549k, R5 = 6.49k, and R6 = 10k shown in Figure 29 set the Under-Voltage threshold at 43V, and the Over-Voltage, turn off threshold to 71V. The Under-Voltage (UV) comparator has a hysteresis of 135mV's (4.6V of hysteresis on the supply) which correlates to a 38.4V turn off voltage. The Over-Voltage comparator has a 25mV hysteresis (1.4V of hysteresis on the supply) which translates to a turn on voltage (supply decreasing) of approximately 69.6V.

Q1 - is the FET that connects the input supply voltage to the output load, when properly enabled. It needs to be selected based on several criteria:

- Maximum voltage expected on the input supply (including transients) as well as transients on the output side.
- Maximum current and power dissipation expected during normal operation, usually at a level just below the current limit threshold.
- Power dissipation and/or safe-operating-area considerations during current limiting and single retry events.
- Other considerations include the GATE voltage threshold which affects the $r_{DS(ON)}$ (which in turn, affects the voltage drop across the FET during normal operation), and the maximum gate voltage allowed (the IC's GATE output is clamped to ~14V).

R1 - is the Over-Current sense resistor also referred to as R_{SENSE} . If the input current is high enough, such that the voltage drop across R1 exceeds the SENSE comparator trip point (50mV nominal), the GATE pin will be pulled lower (to ~4V) and current will be regulated to $50mV/R_{sense}$ for the programmed time-out period which is set by C3. The Over-Current threshold is defined in Equation 3 below. If the time-out period is exceeded the Over-Current latch will be set and the FET will be turned off to protect the load from excessive current. A typical value for R1 is 0.02Ω, which sets an Over-Current trip point of; $I_{OC} = V/R = 0.05/0.02 = 2.5$ Amps. To select the appropriate value for R1, the user must first determine at what level of current it should trip, take into account worst case variations for the trip point (50mV ±10mV = ±20%), and the tolerances of the resistor (typically 1% or 5%). Note that the Over-Current threshold should be set above the inrush current level plus the expected load current to avoid activating the current limit and time-out circuitry during start-up. If the power good output (PWRGD/PWRGD) is used to enable an external module, the desired inrush current only needs to be considered. One rule of thumb is to set the Over-Current threshold 2-3 times higher than the normal operating current.

$$I_{OC} = \frac{50mV}{R_{sense}} \quad (EQ. 3)$$

The physical layout of the R1 sense resistor is critical to avoid the possibility of false over current events. Since it is in the main input-to-output path, the traces should be wide enough to support both the normal current, and currents up to the over-current trip point. The trace routing between the

R1 resistor, and the V_{EE} and SENSE pins should be direct and as short as possible with zero current in the sense lines. Note that in Figure 30 the traces from each side of the R1 resistor also connect to the R8 (IS+), and R7 (IS-) current sensing resistors.

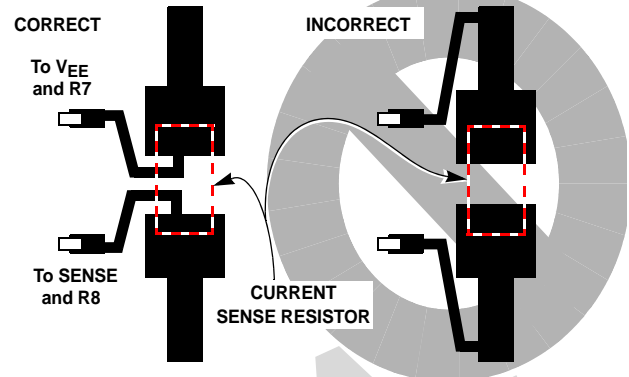

FIGURE 30. SENSE RESISTOR LAYOUT GUIDELINES

CL - is the sum of all load capacitances, including the load's input capacitance itself. Its value is usually determined by the needs of the load circuitry, and not the hot plug (although there can be interaction). For example, if the load is a regulator, then the capacitance may be chosen based on the input requirements of that circuit (holding regulation under current spikes or loading, filtering noise, etc.) The value chosen will affect the peak inrush current. Note that in the case of a regulator, there may be capacitors on the output of that circuit as well; these need to be added into the capacitance calculation during inrush (unless the regulator is delayed from operation by the PWRGD/PWRGD signal).

RL - is the equivalent resistive value of the load and determines the normal operating current delivered through the FET. It also affects some dynamic conditions (such as the discharge time of the load capacitors during a power-down). A typical value might be 48Ω ($I = V/R = 48/48 = A$).

R2, C1, R3, C2 - are related to the GATE driver, as it controls the inrush current.

R2 prevents high frequency oscillations; 10Ω is a typical value. $R2 = 10\Omega$.

R3 and C2 act as a feedback network to control the inrush current as shown in Equation 4, where CL is the load capacitance (including module input capacitance), and I_{PU} is the GATE pin charging current, nominally 50μA.

$$I_{inrush} = I_{PU} \times \frac{C_L}{C_2} \quad (EQ. 4)$$

Begin by choosing a value of acceptable inrush current for the system, and then solve for C2.

C1 and R3 prevent Q1 from turning on momentarily when power is first applied. Without them, C2 would pull the gate of Q1 up to a voltage roughly equal to $V_{EE} \cdot C2/C_{gs}(Q1)$ (where C_{gs} is the FET gate-source capacitance) before the ISL6142/52 could power up and actively pull the gate low. Place C1 in parallel with the gate capacitance of Q1; isolate them from C2 by R3.

C1 = $[(V_{inmax} - V_{th})/V_{th}] \cdot (C2 + C_{gd})$ - where V_{th} is the FET's minimum gate threshold, V_{inmax} is the maximum operating input voltage, and C_{gd} is the FET gate-drain capacitance.

R3 - its value is not critical, a typical value of 18k Ω is recommended but values down to 1k Ω can be used. Lower values of R3 will add delay to gate turn-on for hot insertion and the single retry event following a hard fault.

R7/R8/R9 - are used to sense the load current (R7/R8) and convert the scaled output current ($I_{S_{OUT}}$) to a voltage (R9) that would typically be the input signal to an A to D converter.

R7 is connected between -IS and the R1 sense resistor. These two resistors set the I_{SENSE} (current through the R_{sense} resistor) to $I_{S_{OUT}}$ scaling factor based on Equation 5 below. R8 does not effect the scaling factor but should match R7 to minimize $I_{S_{OUT}}$ error. Their tolerance should be +/-1%, which will typically result in an output current error of less than 5% for a full scale condition. The trace layout is also critical to obtain optimum performance. The traces connecting these resistors to the device pins (IS+ and IS-) and to the R1 sense resistor should be kept as short as possible, match in length, and be isolated from the main current flow as illustrated in Figure 30.

R9 is used to convert the $I_{S_{OUT}}$ current to voltage and is connected between the $I_{S_{OUT}}$ pin and $-V_{IN}$. The current flowing through the resistor (EQ. 5) should not exceed 600 μ A and the voltage on the CT pin will clamp at approximately 8V.

$$I_{S_{OUT}} = I_{SENSE} \times \frac{R_{SENSE}}{R7} \quad (\text{EQ. 5})$$

To select the appropriate resistor values for the application the user must first define the R1 sense resistor value and the maximum load current to be detected/measured. The value of R7 should then be selected such that the maximum $I_{S_{OUT}}$ current is in the 400-500 μ A range. For example, if the user wanted to detect and measure fault currents up to the hard fault comparator trip point (10A); the maximum $I_{S_{OUT}}$ current using the application components in Figure 23 would be $[10A \times (.02/400)] = 500\mu A$. The value of R9 should be set to accommodate the dynamic range of the A to D converter. For this example, a 5k Ω resistor would produce a full scale input voltage to the converter of 2.5V ($500\mu A \times 5k\Omega$). Figures 32 and 33 illustrate the typical output voltage response of the current sense circuit for the Over-Current Time-out and hard fault single retry events.

R10 - is a pull-up resistor for the open drain $\overline{\text{FAULT}}$ output pin which goes active low when the Over-Current latch is set (Over-Current Time-Out). The output signal is referenced to V_{EE} and the resistor is connected to a positive voltage, 5V or less, with respect to V_{EE} . A typical value of 5k Ω is recommended. A fault indicator LED can be placed in series with the pull-up resistor if desired. The resistor value should be selected such that it will allow enough current to drive the LED adequately (brightness).

C3 - is the capacitor used to program the current limit time-out period. When the Over-Current threshold is exceeded a 20 μ A (nominal) current source will charge the C3 capacitor from V_{EE} to approximately 8.5V. When the voltage on the CT pin exceeds the 8.5V threshold, the GATE pin will immediately be pulled low with a 70mA pull down device, the Over-Current latch will be set, and the FET will be turned off. If the Over-Current condition goes away before the time-out period expires, the CT pin will be pulled back down to V_{EE} , and normal operation will resume. Note that any parasitic capacitance from the CT pin to $-V_{IN}$ will effectively add to C3. This additional capacitance should be taken into account when calculating the C3 value needed for the desired time-out period.

The value of C3 can be calculated using Equation 6 where dt is the time-out period, dv is the CT pin threshold, and I_{CT} is the capacitor charging current.

$$C3 = \frac{dt}{dv} \times I_{CT} = \frac{\text{timeout}}{8.5V} \times 20 \times 10^{-6} \quad (\text{EQ. 6})$$

Q2- is an N-channel logic FET used to drive the disable pin (DIS). The DIS pin is used to enable/disable the external pass transistor (Q1) by turning the GATE drive voltage on or off. The DIS pin can also be used to reset the Over-Current latch by toggling the pin high and then low. When Q2 is off, the DIS pin is pulled high with an internal 500k Ω resistor, connected to an internal +5V ($V_{EE} + 5V$) supply rail (10 μ A). In this condition the GATE pin is low, and Q1 is turned off. When Q2 is on, the DIS pin is pulled low to V_{EE} allowing the GATE pin to pull up and turn on Q1. The gate of Q2 will typically be driven low (<1.5V) or High (>3.0V) with external logic circuitry referenced to the negative input ($-V_{IN}$).

Low-side Application

Although this IC was designed for -48V systems, it can also be used as a low-side switch for positive 48V systems; the operation and components are usually similar. One possible difference is the kind of level shifting that may be needed to interface logic signals to the IC. For example, many of the IC functions are referenced to the IC substrate, connected to the V_{EE} pin, but this pin may be considered -48V or GND, depending upon the polarity of the system. Also, the input or output logic (running at 5V or 3.3V or even lower) might be externally referenced to either V_{DD} or V_{EE} of the IC, instead of GND.

Inrush Current Control

The primary function of the ISL6142/52 hot plug controller is to control the inrush current. When a board is plugged into a live backplane, the input capacitors of the board's power supply circuit can produce large current transients as they charge up. This can cause glitches on the system power supply (which can affect other boards!), as well as possibly cause some permanent damage to the power supply.

The key to allowing boards to be inserted into a live backplane is to turn on the power to the board in a controlled manner, usually by limiting the current allowed to flow through a FET switch, until the input capacitors are fully charged. At that point, the FET is fully on, for the smallest voltage drop across it. Figure 31 illustrates the typical inrush current response for a hot insertion under the following conditions:

$$V_{IN} = -48V, R_{sense} = 0.02\Omega$$

$$\text{Current limit} = 50\text{mV}/0.02\Omega = 2.5A$$

$$C1 = 150\text{nF}, C2 = 3.3\text{nF}, R3 = 18\text{k}\Omega$$

$$CL = 100\mu\text{F}, RL = 50\Omega, I_{LOAD} = 48V/50\Omega \sim 1.0A$$

$$I_{inrush} = 50\mu\text{A} (100\mu\text{F}/3.3\text{nF}) = 1.5A$$

After the contact bounce subsides the UVLO and UV criteria are quickly met and the GATE begins to ramp up. As the GATE reaches approximately 4V with respect to the source, the FET begins to turn on allowing current to charge the 100 μ F load capacitor. As the drain to source voltage begins to drop, the feedback network of C2 and R3 hold the GATE constant, in this case limiting the current to approximately 1.5A. When the DRAIN voltage completes its ramp down, the load current remains constant at approximately 1.0A as the GATE voltage increases to its final value.

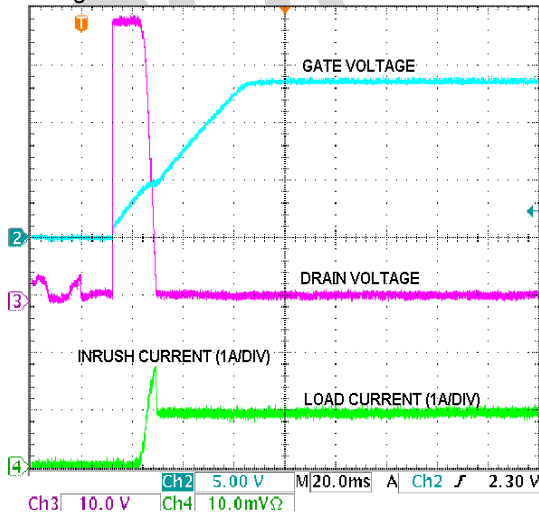

FIGURE 31. HOT INSERTION INRUSH CURRENT LIMITING, DISABLE PIN TIED TO V_{EE}

Electronic Circuit Breaker/Current Limit

The ISL6142/52 allows the user to program both the current limit and the time-out period to protect the system against excessive supply or fault currents. The IntelliTrip™ electronic

circuit breaker is capable of detecting both hard faults, and less severe Over-Current conditions.

The Over-Current trip point is determined by R1 Equation 3) also referred to as R_{sense} . When the voltage across this resistor exceeds 50mV, the current limit regulator will turn on, and the GATE will be pulled lower (to ~4V) to regulate current through the FET at 50mV/ R_{sense} . If the fault persists and current limiting exceeds the programmed time-out period, the FET will be turned off by discharging the GATE pin to V_{EE} . This will set the Over-Current latch and the $\overline{\text{PWRGD}}/\text{PWRGD}$ output will transition to the inactive state, indicating power is no longer good. To clear the latch and initiate a normal start-up sequence, the user must either power down the system (below the UVLO voltage), toggle the UV pin below and above its threshold (usually with an external transistor), or toggle the DIS pin high to low. Figure 32 shows the Over-Current shut down and current limiting response for a 10 Ω short to ground on the output. Prior to the short circuit the output load is 110 Ω producing an operating current of about 0.44A (48V/110 Ω). A 10 Ω short is then applied to the output causing an initial fault current of 4.8A. This produces a voltage drop across the 0.02 Ω sense resistor of approximately 95mV, roughly two times the Over-Current threshold of 50mV. The GATE is quickly pulled low to limit the current to 2.5A (50mV/ R_{sense}) and the timer is enabled. The fault condition persists for the duration of the programmed time-out period (C3 = 1500pF) and the GATE is latched off in about 740 μ s. There is a short filter (3 μ s nominal) on the comparator, so current transients shorter than this will be ignored. Longer transients will initiate the GATE pull down, current limiting, and the timer. If the fault current goes away before the time-out period expires the device will exit the current limiting mode and resume normal operation.

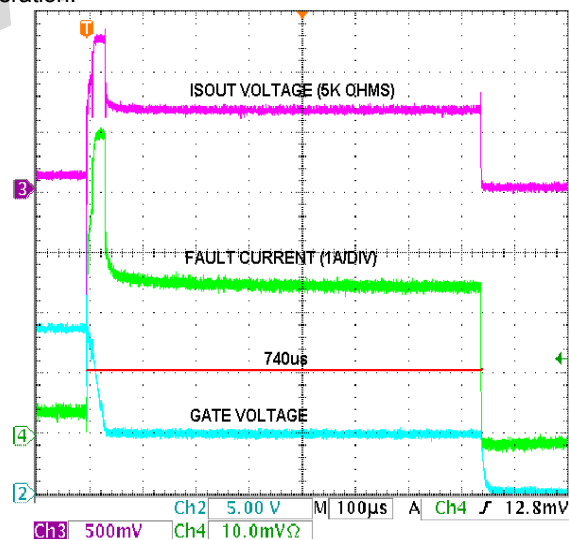

FIGURE 32. CURRENT LIMITING AND TIME-OUT

In addition to current limiting and programmable time-out, there is a hard fault comparator to respond to short circuits with an immediate GATE shutdown (typically 10 μ s) and a single retry. The trip point of this comparator is set ~4 times (210mV) higher than the Over-Current threshold of 50mV. If

the hard fault comparator trip point is exceeded, a hard pull down current (350mA) is enabled to quickly pull down the GATE and momentarily turn off the FET. The fast shutdown resets the timer and is followed by a soft start, single retry event. If the fault is still present after the GATE is slowly turned on, the current limit regulator will trip (sense pin voltage > 50mV), turn on the timer, and limit the current to 50mV/R_{sense}. If the fault remains and the time-out period is exceeded the GATE pin will be latched low. Note: Since the timer starts when the SENSE pin exceeds the 50mV threshold, then depending on the speed of the current transient exceeding 200mV; it's possible that the current limit time-out and shutdown can occur before the hard fault comparator trips (and thus no retry). Figure 33 illustrates the hard fault response with a zero ohm short circuit at the output.

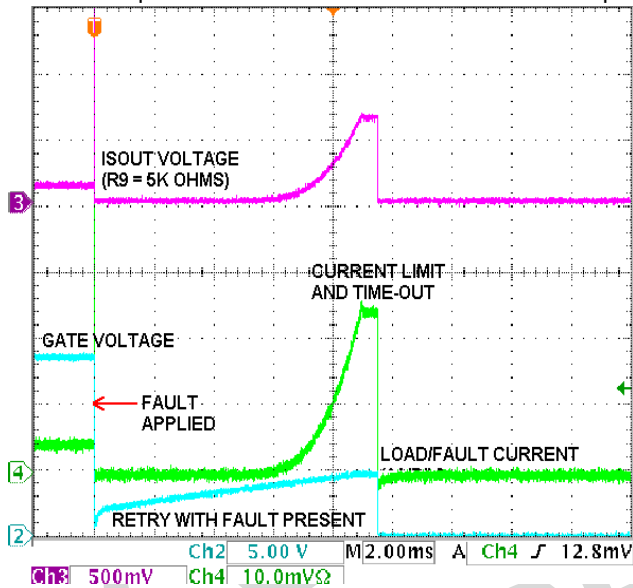

FIGURE 33. HARD FAULT SHUTDOWN AND RETRY

As in the Over-Current Time-Out response discussed previously, the supply is set at -48V and the current limit is set at 2.5A. After the initial gate shutdown (10μs) a soft-start is initiated with the short circuit still present. As the GATE slowly turns on the current ramps up and exceeds the Over-Current threshold (50mV) enabling the timer and current limiting (2.5A). The fault remains for the duration of the time-out period and the GATE pin is quickly pulled low and latched off.

Applications: OV and UV

The UV and OV pins can be used to detect Over-Voltage and Under-Voltage conditions on the input supply and quickly shut down the external FET to protect the system. Each pin is tied to an internal comparator with a nominal reference of 1.255V. A resistor divider between the V_{DD} (gnd) and -V_{IN} is typically used to set the trip points on the UV and OV pins. If the voltage on the UV pin is above its threshold and the voltage on the OV pin is below its threshold, the supply is within its expected operating range

and the GATE will be allowed to turn on, or remain on. If the UV pin voltage drops below its high to low threshold, or the OV pin voltage increases above its low to high threshold, the GATE pin will be pulled low, turning off the FET until the supply is back within tolerance.

The OV and UV inputs are high impedance, so the value of the external resistor divider is not critical with respect to input current. Therefore, the next consideration is total current; the resistors will always draw current, equal to the supply voltage divided by the total resistance of the divider (R₄+R₅+R₆) so the values should be chosen high enough to get an acceptable current. However, to the extent that the noise on the power supply can be transmitted to the pins, the resistor values might be chosen to be lower. A filter capacitor from UV to -V_{IN} or OV to -V_{IN} is a possibility, if certain transients need to be filtered. (Note that even some transients which could momentarily shut off the GATE might recover fast enough such that the GATE or the output current does not even see the interruption).

Finally, take into account whether the resistor values are readily available, or need to be custom ordered. Tolerances of 1% are recommended for accuracy. Note that for a typical 48V system (with a 43V to 72V range), the 43V or 72V is being divided down to 1.255V, a significant scaling factor. For UV, the ratio is roughly 35 times; every 3mV change on the UV pin represents roughly 0.1V change of power supply voltage. Conversely, an error of 3mV (due to the resistors, for example) results in an error of 0.1V for the supply trip point. The OV ratio is around 60. So the accuracy of the resistors comes into play.

The hysteresis of the comparators is also multiplied by the scale factor of 35 for the UV pin (35 * 135mV = 4.7V of hysteresis at the power supply) and 60 for the OV pin (60 * 25mV = 1.5V of hysteresis at the power supply).

With the three resistors, the UV equation is based on the simple resistor divider:

$$1.255 = V_{UV} [(R5 + R6)/(R4 + R5 + R6)] \text{ or}$$

$$V_{UV} = 1.255 [(R4 + R5 + R6)/(R5 + R6)]$$

Similarly, for OV:

$$1.255 = V_{OV} [(R6)/(R4 + R5 + R6)] \text{ or}$$

$$V_{OV} = 1.255 [(R4 + R5 + R6)/(R6)]$$

Note that there are two equations, but 3 unknowns. Because of the scale factor, R₄ has to be much bigger than the other two; chose its value first, to set the current (for example, 50V/500kΩ draws 100μA), and then the other two will be in the 10kΩ range. Solve the two equations for two unknowns. Note that some iteration may be necessary to select values that meet the requirement, and are also readily available standard values.

The three resistor divider (R₄, R₅, R₆) is the recommended approach for most applications, but if acceptable values can't be found, then consider 2 separate resistor dividers

(one for each pin, both from V_{DD} to $-V_{IN}$). This also allows the user to adjust or trim either trip point independently. Some applications employ a short pin ground on the connector tied to R4 to ensure the hot plug device is fully powered up before the UV and OV pins (tied to the short pin ground) are biased. This ensures proper control of the GATE is maintained during power up. This is not a requirement for the ISL6142/52 however the circuit will perform properly if a short pin scheme is implemented (reference Figure 38).

Applications: PWRGD/PWRGD

The PWRGD/PWRGD outputs are typically used to directly enable a power module, such as a DC/DC converter. The PWRGD (ISL6142) is used for modules with active low enable (L version), and PWRGD (ISL6152) for those with an active high enable (H version). The modules usually have a pull-up device built-in, as well as an internal clamp. If not, an external pull-up resistor may be needed. If the pin is not used, it can be left open.

For both versions at initial start-up, when the DRAIN to V_{EE} voltage differential is less than 1.3V and the GATE voltage is within 2.5V (V_{GH}) of its normal operating voltage (13.6V), power is considered good and the PWRGD/PWRGD pins will go active. At this point the output is latched and the comparators above no longer control the output. However a second DRAIN comparator remains active and will drive the PWRGD/PWRGD output inactive if the DRAIN voltage exceeds V_{EE} by more than 8V. The latch is reset by any of the signals that shut off the GATE (Over-Voltage, Under-Voltage; Under-Voltage-Lock-Out; Over-Current Time-Out, disable pin high, or powering down). In this case the PWRGD/PWRGD output will go inactive, indicating power is no longer good.

ISL6142 (L version; Figure 34): Under normal conditions (DRAIN voltage - $V_{EE} < V_{PG}$, and $\Delta V_{GATE} - V_{GATE} < V_{GH}$) the Q2 DMOS will turn on, pulling PWRGD low, enabling the module.

When any of the 5 conditions occur that turn off the GATE (OV, UV, UVLO, Over-Current Time-Out, disable pin high) the PWRGD latch is reset and the Q2 DMOS device will shut off (high impedance). The pin will quickly be pulled high by the external module (or an optional pull-up resistor or equivalent) which in turn will disable it. If a pull-up resistor is used, it can be connected to any supply voltage that doesn't exceed the IC pin maximum ratings on the high end, but is high enough to give acceptable logic levels to whatever signal it is driving. An external clamp may be used to limit the voltage range.

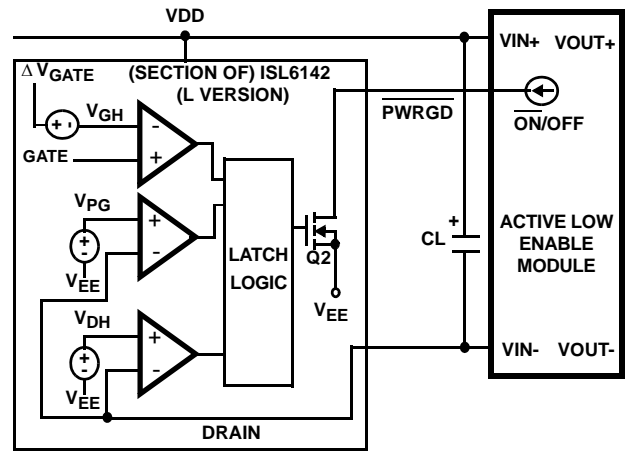

FIGURE 34. ACTIVE LOW ENABLE MODULE

The PWRGD can also drive an opto-coupler (such as a 4N25), as shown in Figure 35 or LED (Figure 36). In both cases, they are on (active) when power is good. Resistors R13 or R14 are chosen based on the supply voltage, and the amount of current needed by the loads.

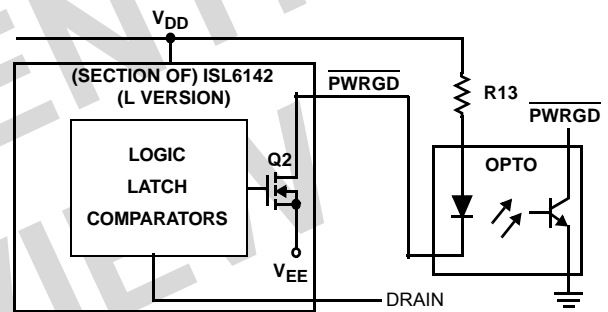

FIGURE 35. ACTIVE LOW ENABLE OPTO-ISOLATOR

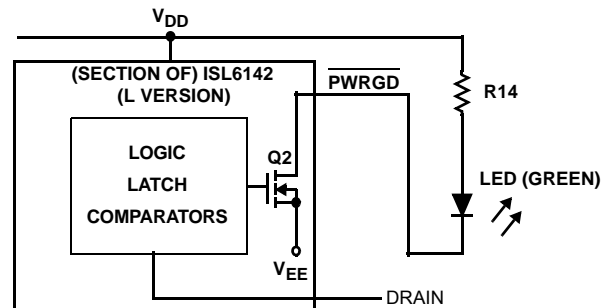

FIGURE 36. ACTIVE LOW ENABLE LED

ISL6152 (H version; Figure 37): Under normal conditions (DRAIN voltage - $V_{EE} < V_{PG}$, and $\Delta V_{GATE} - V_{GATE} < V_{GH}$), the Q3 DMOS will be on, shorting the bottom of the internal resistor to V_{EE} , turning Q2 off. If the pull-up current from the external module is high enough, the voltage drop across the 6.2kΩ resistor will look like a logic high (relative to DRAIN). Note that the module is only referenced to DRAIN, not V_{EE} (but under normal conditions, the FET is on, and the DRAIN and V_{EE} are almost the same voltage).

When any of the 5 conditions occur that turn off the GATE, the Q3 DMOS turns off, and the resistor and Q2 clamp the PWRGD pin to one diode drop ($\sim 0.7V$) above the DRAIN pin. This should be able to pull low against the module pull-up current, and disable the module.

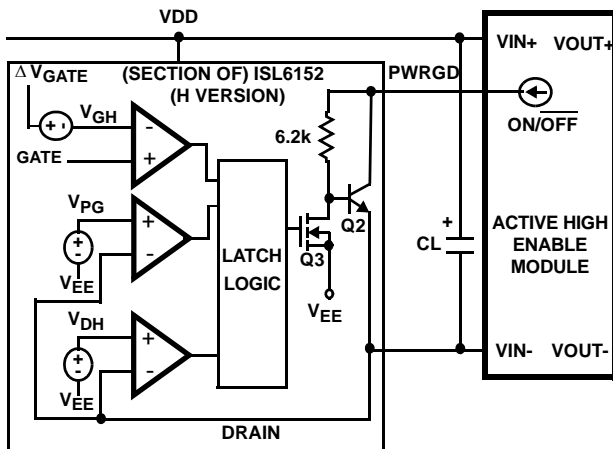

FIGURE 37. ACTIVE HIGH ENABLE MODULE

Applications: GATE Pin

To help protect the external FET, the output of the GATE pin is internally clamped; up to an 80V supply and will not be any higher than 15V. Under normal operation when the supply voltage is above 20V, the GATE voltage will be regulated to a nominal 13.6V above V_{EE} .

Applications: “Brick” Regulators

One of the typical loads used are DC/DC regulators, some commonly known as “brick” regulators, (partly due to their shape, and because it can be considered a “building block” of a system). For a given input voltage range, there are usually whole families of different output voltages and current ranges. There are also various standardized sizes and pinouts, starting with the original “full” brick, and since getting smaller (half-bricks and quarter-bricks are now common).

Other common features may include: all components (except some filter capacitors) are self-contained in a molded plastic package; external pins for connections; and often an ENABLE input pin to turn it on or off. A hot plug IC, such as the ISL6142 is often used to gate power to a brick, as well as turn it on.

Many bricks have both logic polarities available (Enable high or low input); select the ISL6142 (L-version) or ISL6152 (H-version) to match. There is little difference between them, although the L-version output is usually simpler to interface.

The Enable input often has a pull-up resistor or current source, or equivalent built in; care must be taken in the ISL6152 (H version) output that the given current will create a high enough input voltage (remember that current through the RPG 6.2k Ω resistor generates the high voltage level; (see Figure 34).

The input capacitance of the brick is chosen to match its system requirements, such as filtering noise, and maintaining regulation under varying loads. Note that this input capacitance appears as the load capacitance of the ISL6142, ISL6152.

The brick’s output capacitance is also determined by the system, including load regulation considerations. However, it can affect the ISL6142, ISL6152, depending upon how it is enabled. For example, if the $\overline{PWRGD}/PWRGD$ signal is not used to enable the brick, the following could occur. Sometime during the inrush current time, as the main power supply starts charging the brick input capacitors, the brick itself will start working, and start charging its output capacitors and load; that current has to be added to the inrush current. In some cases, the sum could exceed the Over-Current threshold, which could shut down the system if the time-out period is exceeded! Therefore, whenever practical, it is advantageous to use the $\overline{PWRGD}/PWRGD$ output to keep the brick off at least until the input caps are charged up, and then start-up the brick to charge its output caps.

Typical brick regulators include models such as Lucent JW050A1-E or Vicor VI-J30-CY. These are nominal -48V input, and 5V outputs, with some isolation between the input and output.

Applications: Optional Components

In addition to the typical application, and the variations already mentioned, there are a few other possible components that might be used in specific cases. See Figure 38 for some possibilities.

If the input power supply exceeds the 100V absolute maximum rating, even for a short transient, that could cause permanent damage to the IC, as well as other components on the board. If this cannot be guaranteed, a voltage suppressor (such as the SMAT70A, D1) is recommended. When placed from V_{DD} to $-V_{IN}$ on the board, it will clamp the voltage.

If transients on the input power supply occur when the supply is near either the OV or UV trip points, the GATE could turn on or off momentarily. One possible solution is to add a filter cap C4 to the V_{DD} pin, through isolation resistor R11. A large value of R11 is better for the filtering, but be aware of the voltage drop across it. For example, a 1k Ω resistor, with 2.4mA of I_{DD} would have 2.4V across it and dissipate 2.4mW. Since the UV and OV comparators are referenced with respect to V_{EE} , they should not be affected, but the GATE clamp voltage could be offset by the voltage across the extra resistor.

The switch SW1 is shown as a simple push button. It can be replaced by an active switch, such as an NPN or NFET; the principle is the same; pull the UV node below its trip point, and then release it (toggle low). To connect an NFET, for

example, the DRAIN goes to UV; the source to $-V_{IN}$, and the GATE is the input; if it goes high (relative to $-V_{IN}$), it turns the NFET on, and UV is pulled low. Just make sure the NFET resistance is low compared to the resistor divider, so that it has no problem pulling down against it.

R12 is a pull-up resistor for $\overline{\text{PWRGD}}$, if there is no other component acting as a pull-up device. The value of R12 is determined by how much current is needed when the pin is pulled low (also affected by the V_{DD} voltage); and it should be pulled low enough for a good logic low level. An LED can also be placed in series with R12, if desired. In that case, the criteria is the LED brightness versus current.

Applications: Layout Considerations

For the minimum application, there are 10 resistors, 3 capacitors, one IC and 2 FETs. A sample layout is shown in Figure 39. It assumes the IC is 8-SOIC; Q1 is in a D2PAK (or similar SMD-220 package).

Although GND planes are common with multi-level PCBs, for a -48V system, the -48V rails (both input and output) act more like a GND than the top 0V rail (mainly because the IC signals are mostly referenced to the lower rail). So if separate planes for each voltage are not an option, consider prioritizing the bottom rails first.

Note that with the placement shown, most of the signal lines are short, and there should be minimal interaction between them.

Although decoupling capacitors across the IC supply pins are often recommended in general, this application may not need one, nor even tolerate one. For one thing, a decoupling cap would add to (or be swamped out by) any other input capacitance; it also needs to be charged up when power is applied. But more importantly, there are no high speed (or any) input signals to the IC that need to be conditioned. If still desired, consider the isolation resistor R10, as shown in Figure 38.

NOTE:

1. Layout scale is approximate; routing lines are just for illustration purposes; they do not necessarily conform to normal PCB design rules. High current buses are wider, shown with parallel lines.
2. Approximate size of the above layout is 0.8 x 0.8 inches, excluding Q1 (D2PAK or similar SMD-220 package).
3. R1 sense resistor is size 2512; all other R's and C's shown are 0805; they can all potentially use smaller footprints, if desired.
4. The RL and CL are not shown on the layout.
5. Vias are needed to connect R4 and V_{DD} to GND on the bottom of the board, and R8 to pin 9; all other routing can be on the top level.
6. $\overline{\text{PWRGD}}$ signal is not used here.

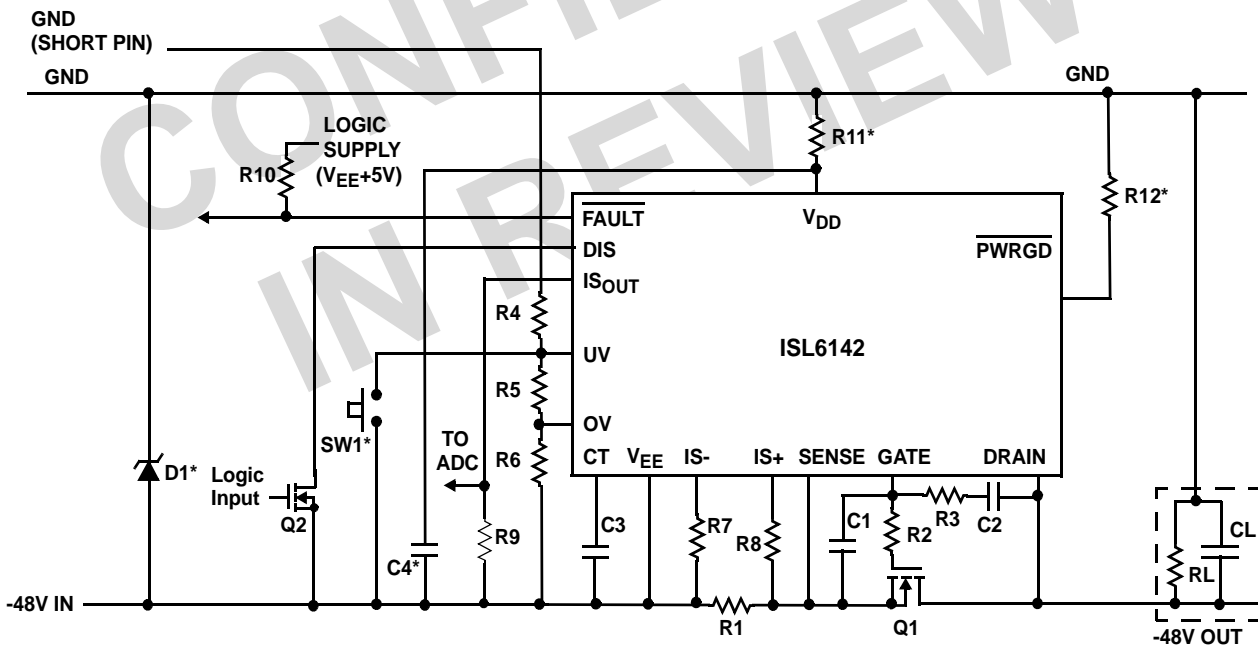

FIGURE 38. ISL6142/52 OPTIONAL COMPONENTS (SHOWN WITH *)

Package Outline Drawing

M14.15

14 LEAD NARROW BODY SMALL OUTLINE PLASTIC PACKAGE

Rev 1, 10/09

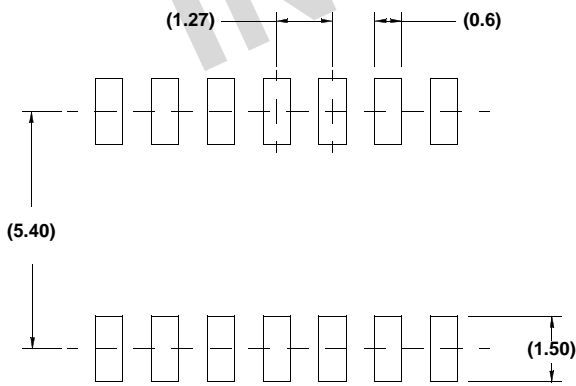
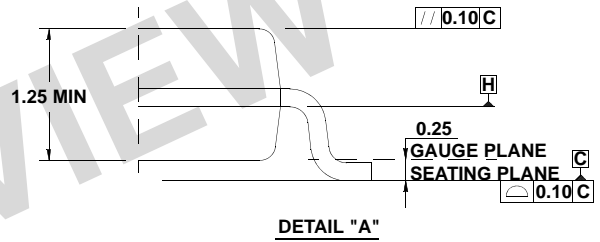
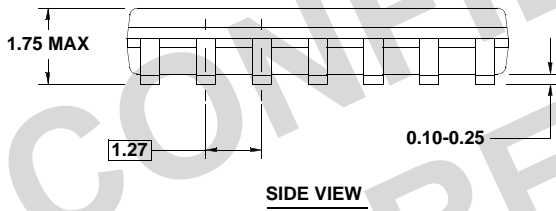
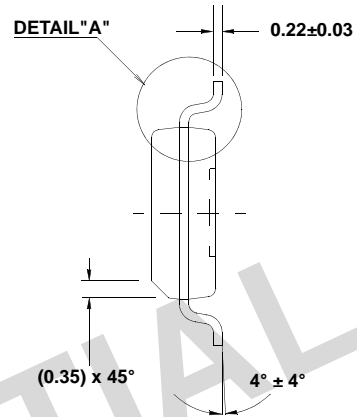
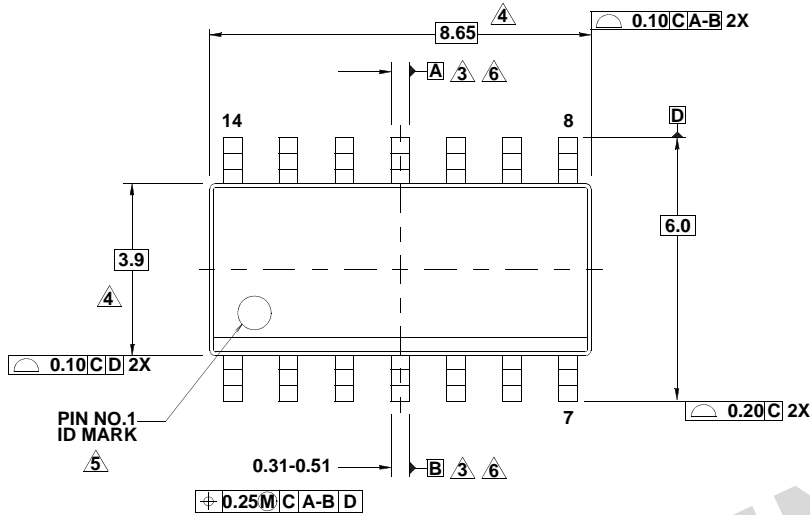

NOTES:

1. Dimensions are in millimeters.
Dimensions in () for Reference Only.
2. Dimensioning and tolerancing conform to AMSEY14.5m-1994.
3. Datums A and B to be determined at Datum H.
4. Dimension does not include interlead flash or protrusions.
Interlead flash or protrusions shall not exceed 0.25mm per side.
5. The pin #1 identifier may be either a mold or mark feature.
6. Does not include dambar protrusion. Allowable dambar protrusion shall be 0.10mm total in excess of lead width at maximum condition.
7. Reference to JEDEC MS-012-AB.