

- NOTES:
1. CRIMP ACCEPTS 22 TO 26 GA. WIRE WITH (.165)/.065 MAX INSULATION DIA.
 2. DIMENSIONS GIVEN ACROSS CENTERLINES ARE SYMMETRICAL ABOUT THOSE CENTERLINES WITHIN HALF THE TOTAL TOLERANCE.
 3. OPTIONAL DESIGN (.86+.05)/.034+.002
 4. TERMINAL CONFORMS TO PRODUCT SPEC. 08-50.
 5. CAT EAR OPTION TO BE USED WITH 41695 HOUSING ONLY.

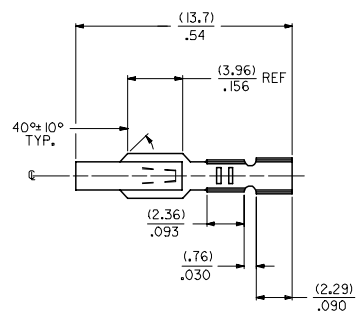
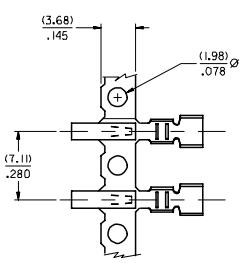
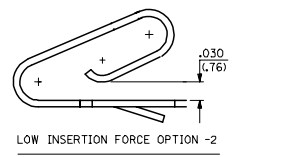
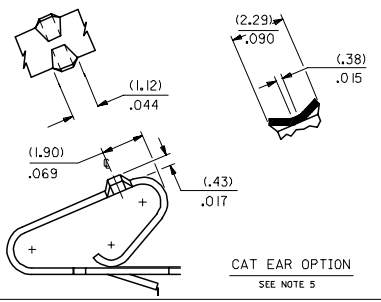

MATERIAL CODE
 (.28)/.0106 THK
 BLANK=BRASS
 B=PHOS BRONZE

WINDING SPEC.
 A=PER ES-339-A
 BLANK=PER ES-339-B
 L=LOOSE

PLATING CODE
 (PER SDES-88)
 *(P909) OVERALL HOT TIN DIP: 2.54 MICROMETERS MIN
 (550) SELECT GOLD: 0.38 MICROMETERS MIN.
 OVERALL GOLD FLASH: 0.05 MICROMETERS MIN.
 OVERALL NICKEL UNDERPLATE: 0.76 MICROMETERS MIN.
 (555) SELECT GOLD: 0.38 MICROMETERS MIN.
 OVERALL NICKEL UNDERPLATE: 0.76 MICROMETERS MIN.

OPTIONS
 BLANK=AS SHOWN
 1=WITH CAT EARS
 2=LOW INSERTION FORCE

*THE PRIMARY SHIPPING CARTON WILL BE LABELED *COMPLIANT TO ROHS DIRECTIVE 2002/95/EC AND ELV ANNEX II OF DIRECTIVE 2000/53/EC.* CARTONS WITHOUT THIS LABEL MAY CONTAIN PRODUCT WITH TIN-LEAD PLATING.

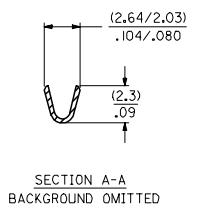
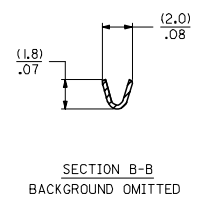
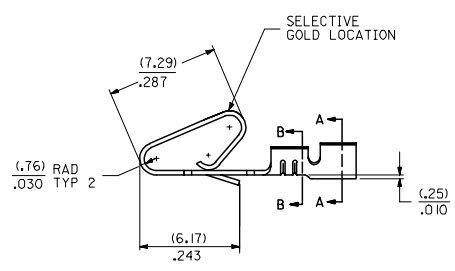
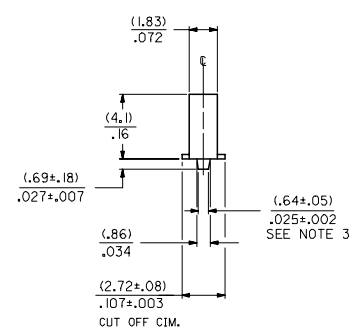

ENTER DESCRIPTION EC NO: UCP2005-0928 DRAWN BY: DRW:ADRIANO CHKD-SAMEC 2004/11/02 APPR:MMG:LLS 2004/11/02 W	QUALITY SYMBOLS	GENERAL TOLERANCES (UNLESS SPECIFIED)		DIMENSION STYLE IN/MM		SCALE	DESIGN UNITS INCH	THIRD ANGLE PROJECTION
	▽=0	4 PLACES ± --- ± ---	mm	INCH	DRAWN BY DATE	TITLE	MATERIAL NO.	DOCUMENT NO.
	▽=0	3 PLACES ± --- ± .010			PEREZ/AR 01/29/87			
		2 PLACES ± 0.25 ± .014			CHECKED BY DATE	MOLEX INCORPORATED SD-2578		
	1 PLACE ± 0.36 ± ---			APPROVED BY DATE				
		ANGULAR ±1/2°			LENZ 01/29/87			
	DRAFT WHERE APPLICABLE MUST REMAIN WITHIN DIMENSIONS		SEE CHART		THIS DRAWING CONTAINS INFORMATION THAT IS PROPRIETARY TO MOLEX INCORPORATED AND SHOULD NOT BE USED WITHOUT WRITTEN PERMISSION			

2578-(***)*		2578-B-(***)*		2578-B-2-(***)*							
PART NO.	ENG. NO.	PART NO.	ENG. NO.	PART NO.	ENG. NO.	PART NO.	ENG. NO.	PART NO.	ENG. NO.	PART NO.	ENG. NO.
08-50-0107	2578-(P909)	08-56-0121	2578-B-(501)		2578-B-2(P909)						
08-50-0108	2578-(P909)L	08-56-0122	2578-B-(501)L		2578-B-2(P909)L						
08-50-0111	2578-(109)	08-50-0133 *	2578-B-(P909)		2578-B-2(555)						
08-50-0112	2578-(109)L	08-50-0134 *	2578-B-(P909)L		2578-B-2(555)L						
08-56-0107	2578-(550)	08-65-0116 *	2578-B-(555)		2578-B-2(550)						
08-56-0108	2578-(550)L	08-65-0117 *	2578-B-(555)L		2578-B-2(550)L						
08-55-0105	2578-(555)	08-65-0108	2578-B-(591)								
08-56-0106	2578-(555)L	08-65-0107	2578-B-(591)L								
08-59-0101	2578-(122)	08-60-0003	2578-B-(122)								
	2578-(122)L	08-60-0004	2578-B-(122)L								
1 08-56-0162	2578-(505)	08-65-0110	2578-B-(558)								
1 08-56-0163	2578-(505)L	08-65-0111	2578-B-(558)L								
08-50-0504	2578-(128)	08-58-0125 *	2578-B-(550)								
	2578-(128)L	08-58-0126 *	2578-B-(550)L								
08-56-0161	2578-(503)										
	2578-(503)L										
1 08-50-0061	2578-(224)										
1 08-50-0062	2578-(224)L										
1 08-50-0065	2578-(P224)										
1 08-50-0066	2578-(P224)L										
08-55-0137	2578-(558)A										
	2578-(558)L										
08-50-0018	2578-(102)										
08-50-0019	2578-(102)L										
08-55-0121	2578-(561)										
08-55-0132	2578-(561)L										
08-55-0123	2578-(558)										
	2578-(558)L										
08-65-0109	2578-(555)A										
08-52-0116	2578-(P909)										
08-52-0117	2578-(P9109)L										

CHANGE TO ME10 EC NO: UCP2005-0928 DRW:ADRIANO 2004/11/16 CHK:CSAMEC 2004/11/02 APPR: MARGULLIS 2004/11/02 W	QUALITY SYMBOLS ▽=0 ▽=0	GENERAL TOLERANCES (UNLESS SPECIFIED) <table border="1"> <tr> <th></th> <th>mm</th> <th>INCH</th> </tr> <tr> <td>4 PLACES</td> <td>± .005</td> <td>± .0005</td> </tr> <tr> <td>3 PLACES</td> <td>± .005</td> <td>± .0005</td> </tr> <tr> <td>2 PLACES</td> <td>± .005</td> <td>± .0005</td> </tr> <tr> <td>1 PLACE</td> <td>± .005</td> <td>± .0005</td> </tr> </table>		mm	INCH	4 PLACES	± .005	± .0005	3 PLACES	± .005	± .0005	2 PLACES	± .005	± .0005	1 PLACE	± .005	± .0005	DIMENSION STYLE IN/MM	SCALE INCH	DESIGN UNITS INCH	THIRD ANGLE PROJECTION
		mm	INCH																		
	4 PLACES	± .005	± .0005																		
	3 PLACES	± .005	± .0005																		
2 PLACES	± .005	± .0005																			
1 PLACE	± .005	± .0005																			
DRAWN BY PEREZ/AR	DATE 01/29/87	CHECKED BY PATEL	DATE 01/29/87	APPROVED BY LENZ	DATE 01/29/87	MATERIAL NO. MOLEX INCORPORATED															
DRAFT WHERE APPLICABLE MUST REMAIN WITHIN DIMENSIONS		SEE CHARTS		DOCUMENT NO. SD-2578		SHEET NO. 2															
THIS DRAWING CONTAINS INFORMATION THAT IS PROPRIETARY TO MOLEX INCORPORATED AND SHOULD NOT BE USED WITHOUT WRITTEN PERMISSION																					