

***RoHS Compliant***

# **SATA-Disk Module II**

***Specification for 7P/180D Low Profile***

**January 18, 2011**

***Version 1.2***



***Apacer Technology Inc.***

4<sup>th</sup> Fl., 75 Xintai 5<sup>th</sup> Rd., Sec.1, Hsichih, New Taipei City, Taiwan 221

Tel: +886-2-2698-2888 Fax: +886-2-2698-2889

[www.apacer.com](http://www.apacer.com)

## Features:

- **Standard Serial ATA 2.6 (Gen. 2)**
  - Serial ATA 2.6 (Gen. 2)
  - SATA II, 3.0 Gbps
  - ATA-compatible command set
- **Capacities**
  - 512 MB
  - 1, 2, 4 GB
- **Performance**
  - Burst read/write: 300 MB/sec
  - Sustained read: up to 27 MB/sec
  - Sustained write: up to 23 MB/sec
- **Intelligent endurance design**
  - Built-in hardware BCH ECC, correcting 8-bit or 15-bit error per 512-byte data sector
  - Static wear-leveling scheme together with dynamical block allocation to significantly increase the lifetime of a flash device and optimize the disk performance
  - Flash bad-block management
  - S.M.A.R.T.
- **NAND Flash Type: SLC**
- **Data integrity under power-cycling**
  - No battery required for data storage
- **Temperature**
  - 0°C to 70°C for operating
  - -40°C to 100°C for storage
- **Supply voltage**
  - 3.3 V /5 V
- **Low power consumption**
  - Active mode: 230 mA\* /165 mA (3.3 V /5 V)
  - Idle mode: 165 mA\* /112 mA (3.3 V /5 V)
- **Connector**
  - 7-pin SATA female connector
  - 2-pin SATA power connector
- **RoHS compliant**

\*Based on 2 GB model

---

## Table of Contents

<b>1. Product Description .....</b>	<b>3</b>
1.1 Introduction .....	3
1.2 Functional Block Diagram.....	3
1.3 ATA Mode Support.....	4
1.4 Capacity Specification .....	4
1.5 Performance .....	4
1.6 Pin Assignments .....	5
<b>2. Software Interface .....</b>	<b>7</b>
2.1 Command Set .....	7
<b>3. Flash Management .....</b>	<b>8</b>
3.1 Error Correction/Detection.....	8
3.2 Bad Block Management.....	8
3.3 Wear Leveling .....	8
3.4 Power Failure Management.....	8
3.5 S.M.A.R.T.....	9
<b>4. Environmental Specifications .....</b>	<b>10</b>
4.1 Environments .....	10
<b>5. Electrical Specification .....</b>	<b>11</b>
<b>6. Physical Characteristics.....</b>	<b>12</b>
6.1 Power Cable-less Type .....	12
6.2 Power Cable Type .....	14
<b>7. Product Ordering Information .....</b>	<b>16</b>
7.1 Product Code Designations .....	16
7.2 Valid Combinations.....	17

# 1. Product Description

## 1.1 Introduction

Apacer's SATA Disk Module (SDM) is a solid-state disk (SSD) drive that contains a controller, embedded firmware, and flash media along with a male connector. Using NAND flash memory devices, the SDM drive interfaces with the host allowing data to be seamlessly transferred between the host and the flash devices.

The SDM drive is designed with a single-chip controller, offering capacities of up to four gigabytes and providing full support for the SATA II high-speed interface standard. It can operate at sustained access rates of up to thirty five megabytes per second, which is much faster than any other competitor in the market.

In addition to buffer management through dynamical allocation, the SDM adopts the static wear-leveling scheme to allow uniform use of all storage blocks, ensuring that the lifetime of a flash media can be significantly increased and the disk performance is optimized as well. The SDM provides the S.M.A.R.T. feature complies to the SATA Rev. 2.6, ATA/ATAPI-7 specifications and uses the standard SMART command B0h to read data from the drive. This feature protects the user from unscheduled downtime by monitoring and storing critical drive performance.

## 1.2 Functional Block Diagram

The SDM drive includes a single-chip SATA II controller and the flash media, as well as the SATA standard interface. The controller integrates the flash management unit with the controller itself to support multi-channel, multi-bank flash arrays. Figure 1-1 shows the functional block diagram.

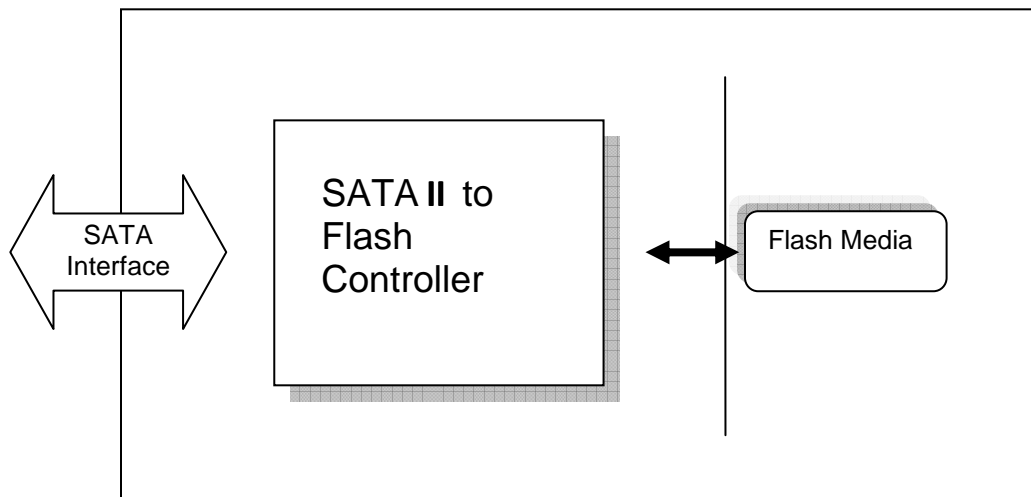

Figure 1-1 Apacer SDM block diagram

### 1.3 ATA Mode Support

The SDM provides ATA mode support as follows:

- Up to PIO mode-4
- Up to Multiword DMA mode-2
- Up to UDMA mode-5

### 1.4 Capacity Specification

Capacity specification of the SDM product family is available as shown in Table 1-1. It lists the specific capacity, the default numbers of logical cylinders and heads, and the number of logical sectors per track for each product line.

**Table 1-1:** Capacity specifications

Capacity	Total Bytes	Cylinders	Heads	Sectors	Max LBA
512 MB	487,710,720	945	16	63	952,560
1 GB	992,968,704	1,924	16	63	1,939,392
2 GB	2,002,452,480	3,880	16	63	3,911,040
4 GB	4,021,936,128	7,793	16	63	7,855,344

### 1.5 Performance

Performance of the SDM is shown in Table 1-2

**Table 1-2:** Performance

Capacity	512 MB	1 GB	2 GB	4 GB
Performance				
Sustained read (MB/s)	22	27	27	27
Sustained write (MB/s)	8	12	22	23

Note: Performances vary from flash configurations.

## 1.6 Pin Assignments

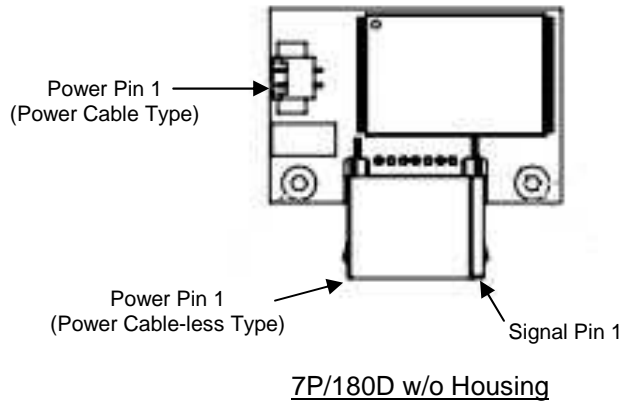

**Table 1-3:** Signal segment

Name	Type	Description
S1	GND	
S2	RxP	+ Differential Receive Signal
S3	RxN	- Differential Receive Signal
S4	GND	
S5	TxN	- Differential Transmit Signal
S6	TxP	+ Differential Transmit Signal
S7	GND	

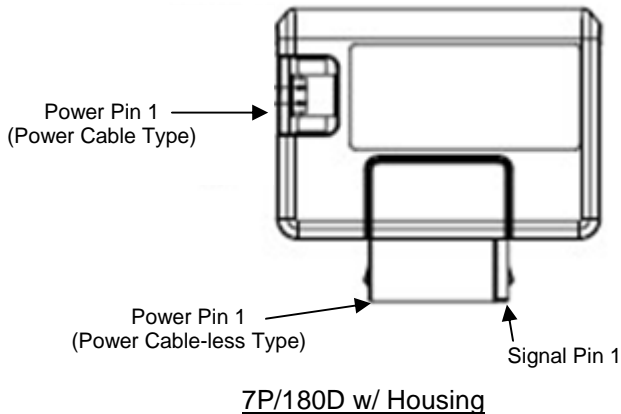

**Table 1-4:** Power segment

Pin	Signal/Description
P1	VCC (5V)
P2	GND

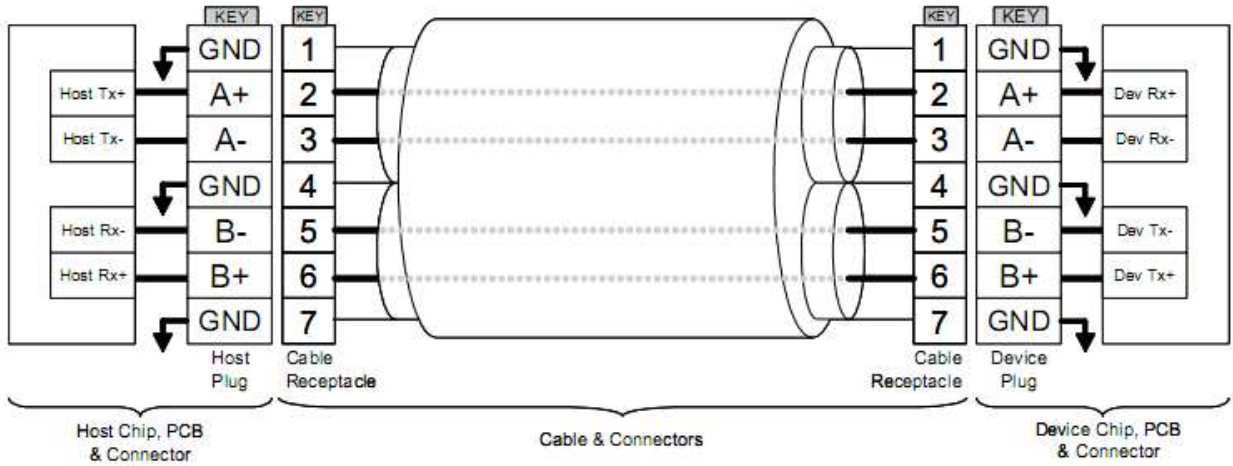

**Figure 1-2** SATA Cable/Connector Connection Diagram

The connector on the left represents the Host with TX/RX differential pairs connected to a cable. The connector on the right shows the Device with TX/RX differential pairs also connected to the cable. Notice also the ground path connecting the shielding of the cable to the Cable Receptacle.

## 2. Software Interface

### 2.1 Command Set

Table 2-1 summarizes the ATA commands supported by the SDM.

**Table 2-1** Command set

Command Name	Code (Hex)	FR <sup>1</sup>	SC <sup>2</sup>	SN <sup>3</sup>	CY <sup>4</sup>	DH <sup>5</sup>	LBA <sup>6</sup>
Check-Power-Mode	E5h	-	-	-	-	D <sup>8</sup>	-
Flush-Cache	E7h	-	-	-	-	D	-
Identify-Drive	ECh	-	-	-	-	D	-
Idle	E3h	-	Y <sup>7</sup>	-	-	D	-
Idle-Immediate	E1h	-	-	-	-	D	-
Initialize-Drive-Parameters	91h	-	Y	-	-	Y	-
Recalibrate	10h	-	-	-	-	D	-
Read-DMA	C8h	-	Y	Y	Y	Y	Y
Read-Multiple	C4h	-	Y	Y	Y	Y	Y
Read-Sector(s)	20h	-	Y	Y	Y	Y	Y
Read-Verify-Sector(s)	40h	-	Y	Y	Y	Y	Y
SMART	B0h	-	Y	Y	Y	D	Y
Set-Features	EFh	Y	-	-	-	D	-
Set-Multiple-Mode	C6h	-	Y	-	-	D	-
Sleep	E6h	-	-	-	-	D	-
Standby	E2h	-	-	-	-	D	-
Standby-Immediate	E0h	-	-	-	-	D	-
Write-DMA	CAh	-	Y	Y	Y	Y	Y
Write-Multiple	C5h	-	Y	Y	Y	Y	Y
Write-Sector(s)	30h	-	Y	Y	Y	Y	Y

1. FR - Features register
2. SC - Sector Count register
3. SN - Sector Number register
4. CY - Cylinder High/Low registers
5. DH - Drive/Head Number register
6. LBA - Logical Block Address mode supported
7. Y - The register contains a valid parameter for this command.
8. For the Drive/Head register:
  - Y means both the SDM and Head parameters are used;
  - D means only the SDM parameter is valid, and not for the Head parameter.



---

## 3. Flash Management

### 3.1 Error Correction/Detection

---

The SDM implements a hardware ECC scheme, based on the BCH algorithm. It can detect and correct up to 8 bits or 15 bits error in 512 bytes.

### 3.2 Bad Block Management

---

Although bad blocks on the flash media are already identified by the flash manufacturer, they can also be accumulated over time during operation. The SDM's controller maintains a table that lists those normal blocks with disk data, the free blocks for wear leveling, and bad blocks with errors. When a normal block is detected broken, it is replaced with a free block and listed as a bad block. When a free block is detected broken, it is then removed from the free block list and marked as a bad block.

During device operation, this ensures that newly accumulated bad blocks are transparent to the host. The device will stop file write service once there are only two free blocks left such that the read function is still available for copying the files from the disk into another.

### 3.3 Wear Leveling

---

The NAND flash devices are limited by a certain number of write cycles. When using a FAT-based file system, frequent FAT table updates are required. If some area on the flash wears out faster than others, it would significantly reduce the lifetime of the whole SSD, even if the erase counts of others are far from the write cycle limit. Thus, if the write cycles can be distributed evenly across the media, the lifetime of the media can be prolonged significantly. This scheme is called wear leveling.

Apacer's wear-leveling scheme is achieved both via buffer management and Apacer-specific static wear leveling. They both ensure that the lifetime of the flash media can be increased, and the disk access performance is optimized as well.

### 3.4 Power Failure Management

---

The Low Power Detection on the controller initiates crucial data saving before the power supplied to the device is too low. This feature prevents the device from crash and ensures data integrity during an unexpected power-off.

---

## **3.5 S.M.A.R.T.**

---

S.M.A.R.T. is an acronym for Self-Monitoring, Analysis and Reporting Technology, an open standard allowing disk drives to automatically monitor their own health and report potential problems. It protects the user from unscheduled downtime by monitoring and storing critical drive performance and calibration parameters. Ideally, this should allow taking proactive actions to prevent impending drive failure.

Apacer SDM uses the standard SMART command B0h to read data from the drive for SMART feature as the SATA Rev. 2.6 ATA/ATAPI-7 specifications. Based on the SFF-8035i Rev. 2.0 specifications, Apacer SMART defines 3 vendor-specified SMART Attribute IDs (E5h, EAh-EBh, and E8h) in the SDM. They represent Flash ID, maximum erase count, average erase count, good block count, free-list block count, and firmware version information. When the Apacer SMART Utility running on the host, it analyzes and reports the disk status to the host before the SDM is in critical condition.

---

## 4. Environmental Specifications

### 4.1 Environments

---

The SDM environmental specifications follow the US Military Standard MIL-STD-810F, as shown in Table 4-1.

**Table 4-1** SDM environmental specifications (plan)

Environment	Specification
Temperature	0°C to 70°C (Operating)
	-40°C to 100°C (Non-operating)
Humidity	5% to 95% RH (Non-condensing)
Vibration	Sine wave: 5~55~5 Hz (X, Y, Z) Random: 10-2000 Hz, 16.3 G (X, Y, Z)
Shock	Acceleration: 1,500 G, 0.5 ms Peak acceleration: 50 G, 11 ms

## 5. Electrical Specification

**Caution: Absolute Maximum Stress Ratings** – (Applied conditions greater than those listed under “Absolute Maximum Stress Ratings” may cause permanent damage to the device. This is a stress rating only and functional operation of the device at these conditions or conditions greater than those defined in the operational sections of this data sheet is not implied. Exposure to absolute maximum stress rating conditions may affect device reliability.

**Table 5-1:** Operating voltage

Ambient Temperature	3.3V	5V
0°C to 70°C	3.135-3.465V	4.75-5.25V

**Table 5-2:** Absolute maximum power pin stress ratings

Parameter	Symbol	Conditions
Input Power	$V_{DD}$	-0.3V min. to 6.5V max.
Voltage on any pin except $V_{DD}$ with respect to GND	V	-0.5V min. to $V_{DD} + 0.5V$ max.

## 6. Physical Characteristics

### 6.1 Power Cable-less Type

#### 6.1.1 W/O Housing (Refer to SDM Power Cable-less Design Guide)

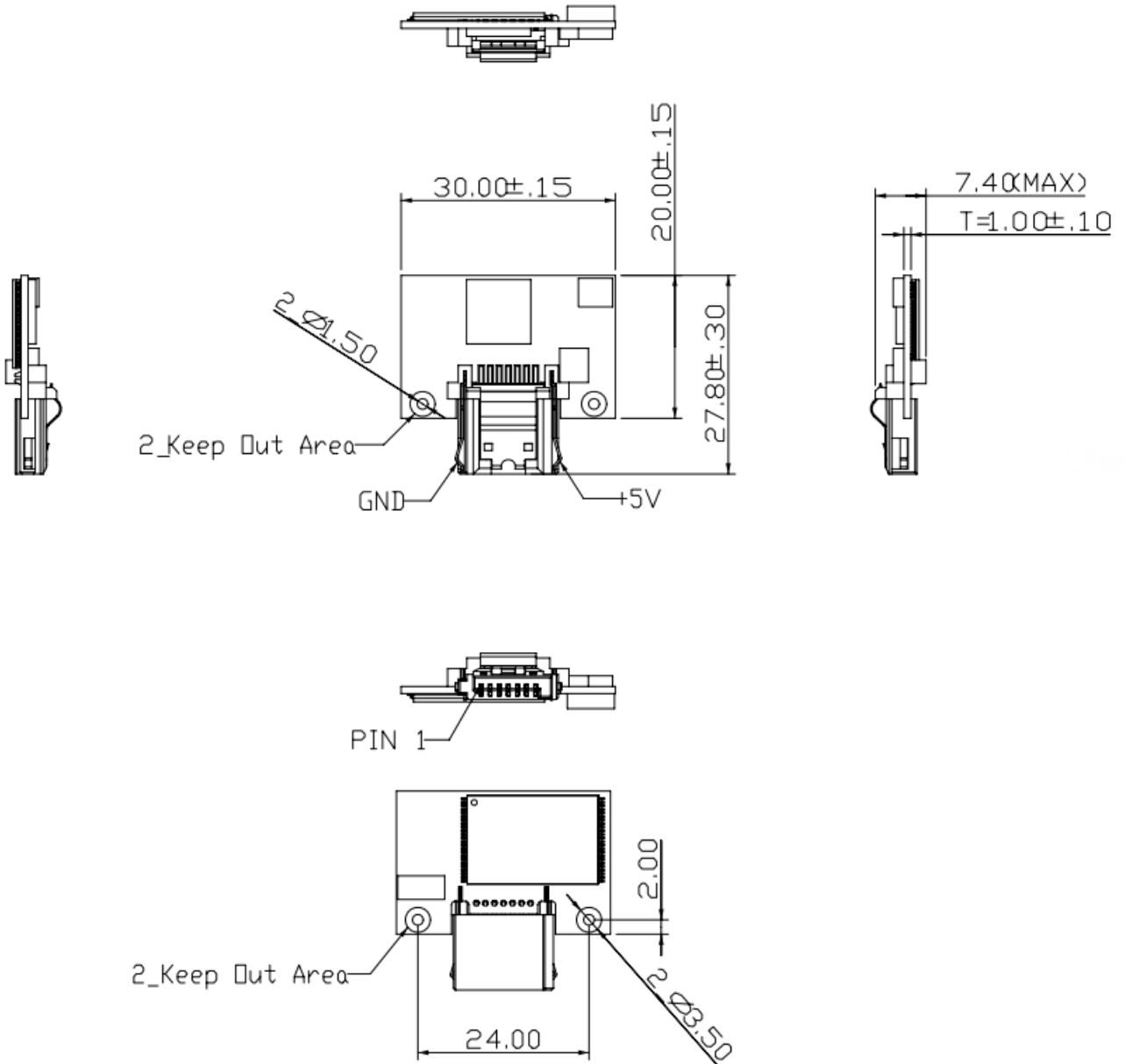

Unit: mm  
 Tolerance:  $\pm 0.25$

# SATA-Disk Module II AP-SDMxxxxXPANS-HTX



## 6.1.2 W/Housing (Refer to SDM Power Cable-less Design Guide)

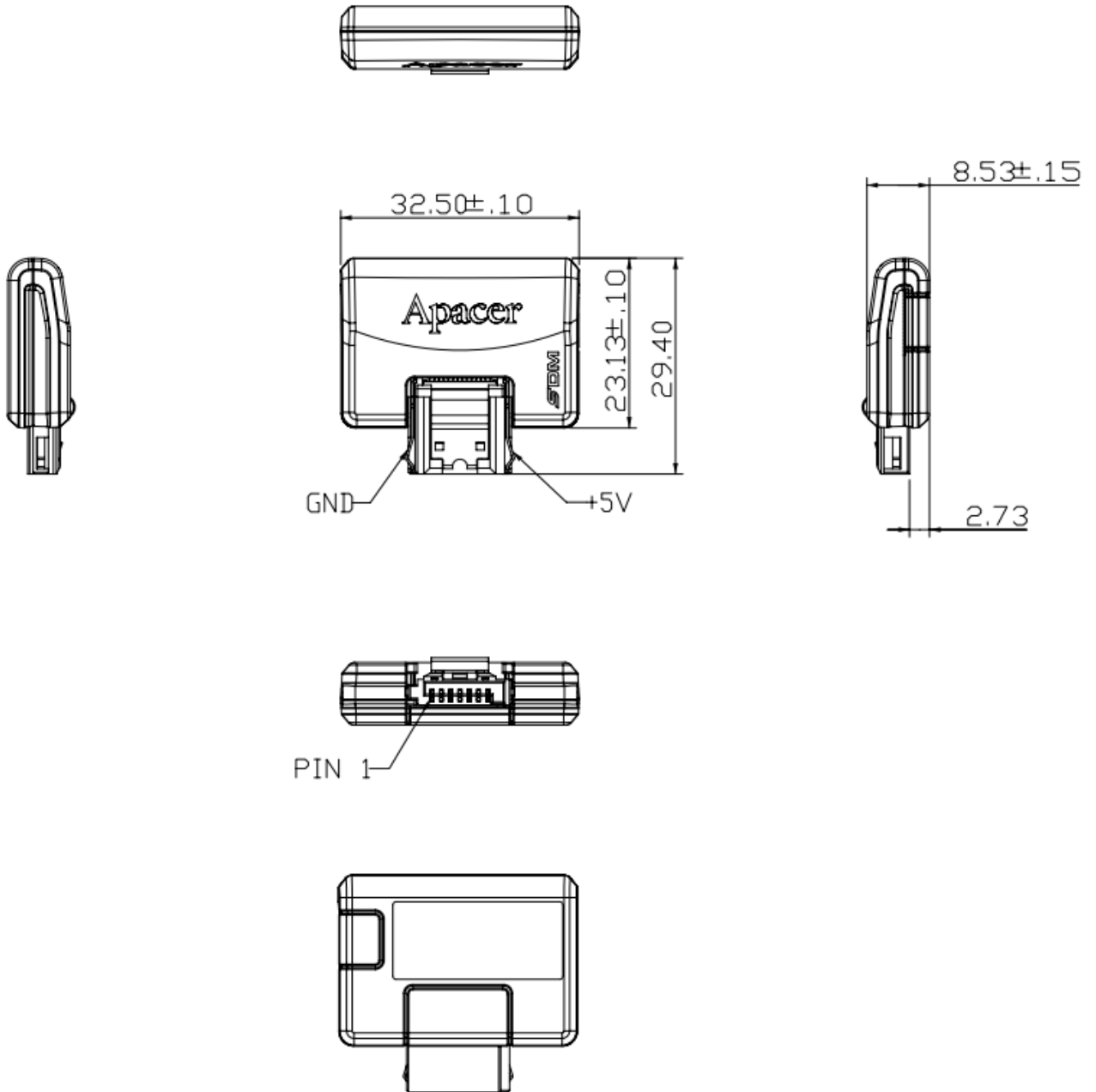

Unit: mm  
Tolerance:  $\pm 0.25$

## 6.2 Power Cable Type

### 6.2.1 W/O Housing

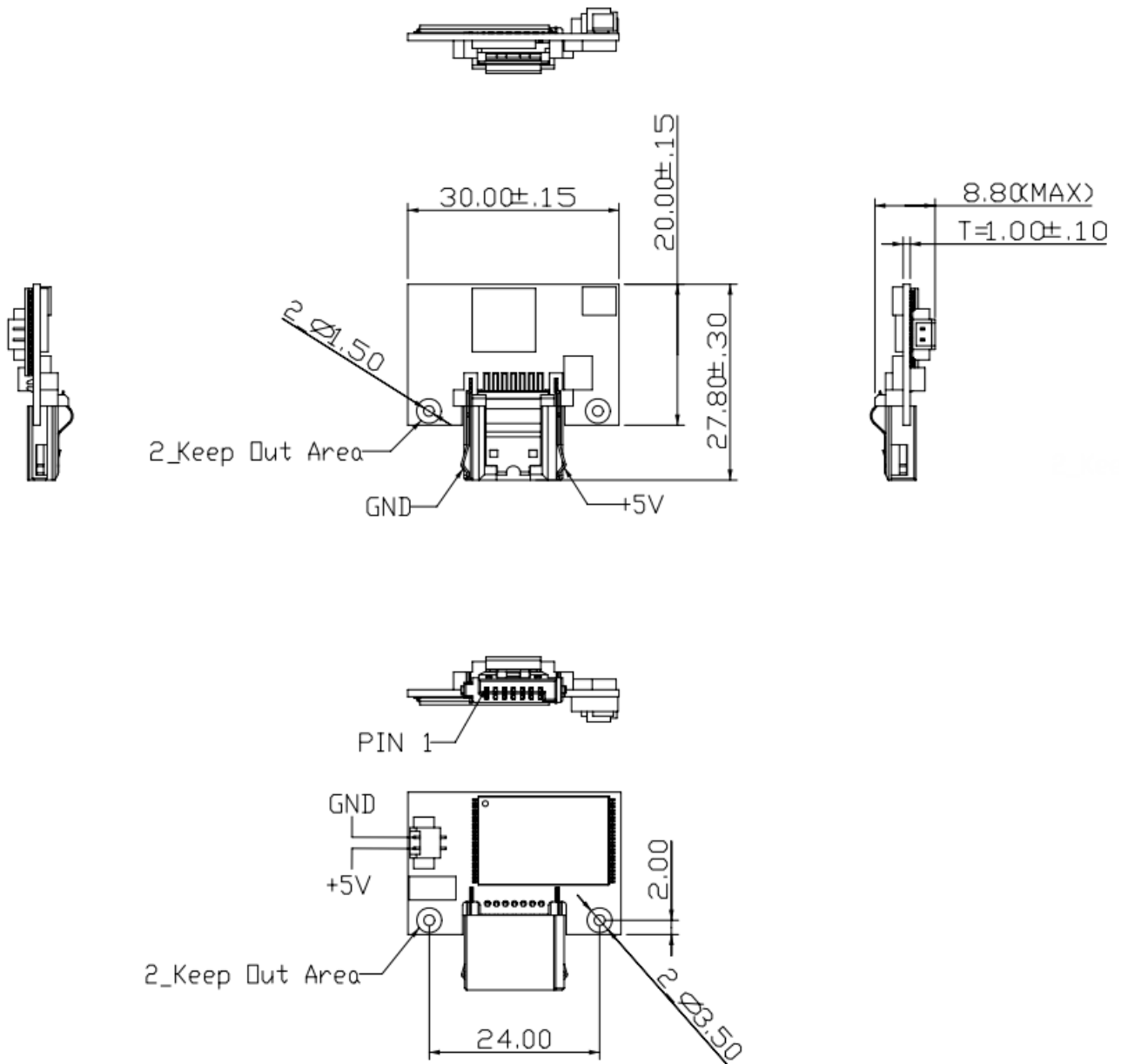

Unit: mm  
 Tolerance:  $\pm 0.25$

SATA-Disk Module II  
AP-SDMxxxxXPANS-HTX

6.2.2 W/Housing

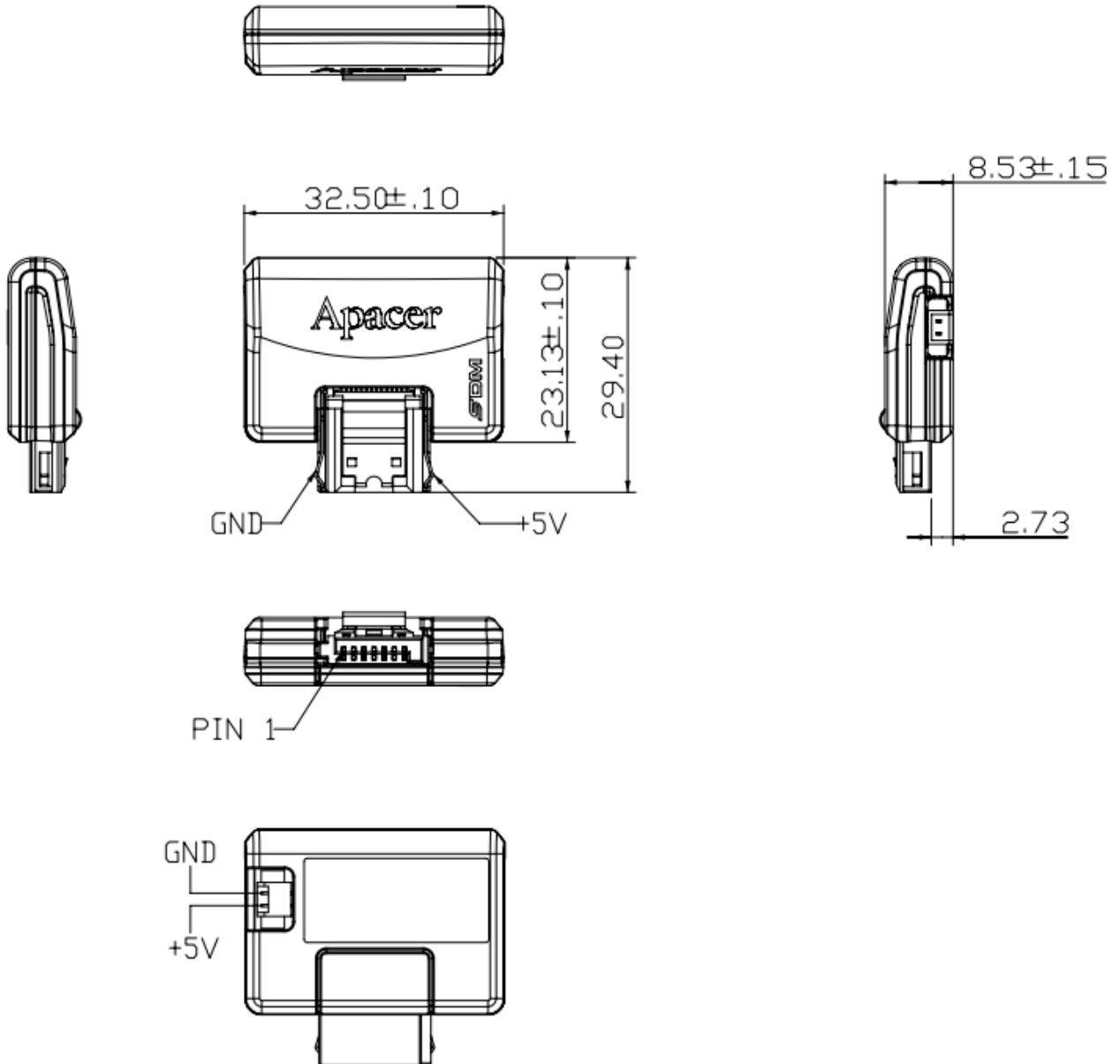

Unit: mm  
Tolerance:  $\pm 0.25$



## 7. Product Ordering Information

### 7.1 Product Code Designations

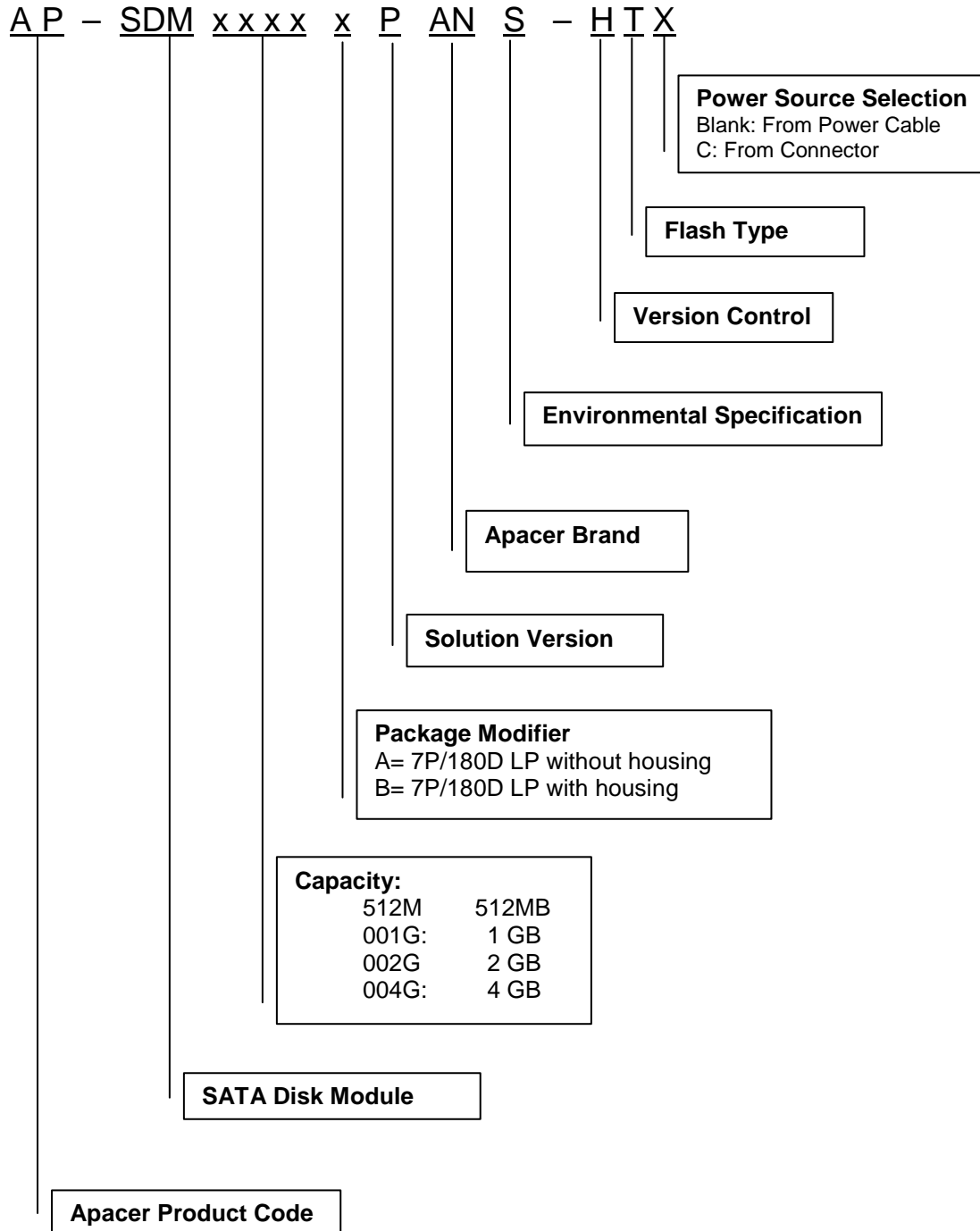

---

## 7.2 Valid Combinations

---

### 7P/180D Low Profile without housing; Power Source from Cable

Capacity	Model Number
512MB	AP-SDM512MAPANS-HT
1GB	AP-SDM001GAPANS-HT
2GB	AP-SDM002GAPANS-HT
4GB	AP-SDM004GAPANS-HT

### 7P/180D Low Profile without housing; Power Source from Connector

Capacity	Model Number
512MB	AP-SDM512MAPANS-HTC
1GB	AP-SDM001GAPANS-HTC
2GB	AP-SDM002GAPANS-HTC
4GB	AP-SDM004GAPANS-HTC

### 7P/180D Low Profile with housing; Power Source from Cable

Capacity	Model Number
512MB	AP-SDM512MBPANS-HT
1GB	AP-SDM001GBPANS-HT
2GB	AP-SDM002GBPANS-HT
4GB	AP-SDM004GBPANS-HT

### 7P/180D Low Profile with housing; Power Source from Connector

Capacity	Model Number
512MB	AP-SDM512MBPANS-HTC
1GB	AP-SDM001GBPANS-HTC
2GB	AP-SDM002GBPANS-HTC
4GB	AP-SDM004GBPANS-HTC

**Note:** Valid combinations are those products in mass production or will be in mass production. Consult your Apacer sales representative to confirm availability of valid combinations and to determine availability of new combinations.

---

## Revision History

Revision	Date	Description	Remark
0.1	03/17/2009	Preliminary	
0.2	03/30/2009	Updated product ordering information	
0.3	04/02/2009	Updated 8GB model details & pin assignments	
0.4	04/06/2009	Updated context	
0.5	04/22/2009	Updated drawings and feature context	
0.6	08/11/2009	Updated feature wording & performance table	
0.7	08/18/2009	Updated wording on physical characteristics	
1.0	10/28/2009	Official release	
1.1	11/05/2010	Added 3.3V support at supply voltage	
1.2	01/18/2011	Updated product ordering information	

---

## Global Presence

<b>Taiwan (Headquarters)</b>	<b>Apacer Technology Inc.</b> 4 <sup>th</sup> Fl, 75 Xintai 5 <sup>th</sup> Rd., Sec.1 Hsichih, New Taipei City Taiwan, 221 R.O.C. Tel: +886-2-2698-2888 Fax: +886-2-2698-2889 <a href="mailto:amtsales@apacer.com">amtsales@apacer.com</a>
<b>U.S.A.</b>	<b>Apacer Memory America, Inc.</b> 386 Fairview Way, Suite102, Milpitas, CA 95035 Tel: 1-408-518-8699 Fax: 1-408-935-9611 <a href="mailto:sa@apacerus.com">sa@apacerus.com</a>
<b>Japan</b>	<b>Apacer Technology Corp.</b> 5F, Matsura Bldg., Shiba, Minato-Ku Tokyo, 105-0014, Japan Tel: 81-3-5419-2668 Fax: 81-3-5419-0018 <a href="mailto:jpsservices@apacer.com">jpsservices@apacer.com</a>
<b>Europe</b>	<b>Apacer Technology B.V.</b> Aziëlaan 22, 5232 BA 's-Hertogenbosch, The Netherlands Tel: 31-73-645-9620 Fax: 31-73-645-9629 <a href="mailto:sales@apacer.nl">sales@apacer.nl</a>
<b>China</b>	<b>Apacer Electronic (Shanghai) Co., Ltd</b> 1301, No.251,Xiaomuqiao Road, Shanghai, 200032, China Tel: 86-21-5529-0222 Fax: 86-21-5206-6939 <a href="mailto:sales@apacer.com.cn">sales@apacer.com.cn</a>
<b>India</b>	<b>Apacer Technologies Pvt Ltd,</b> #1064, 1st Floor, 7th 'A' Main, 3rd Block Koramangala, Bangalore – 560 034 Tel: +91 80 4152 9061/62/63 Fax: +91 80 4170 0215 <a href="mailto:sales_india@apacer.com">sales_india@apacer.com</a>

# Mouser Electronics

Authorized Distributor

Click to View Pricing, Inventory, Delivery & Lifecycle Information:

[Apacer:](#)

[AP-SDM001GAPANS-HT](#) [AP-SDM001GBPANS-HT](#) [AP-SDM004GAPANS-HT](#) [AP-SDM004GBPANS-HT](#)