

# Geartooth Speed Sensors



- ▶ Back To Main Products Page
- ▶ Sensor News
- ▶ Sensor FAQs
- ▶ Operating a Speed Sensor
- ▶ Operating a Reed Sensor
- ▶ Technical Articles
- ▶ Find a Rep
- ▶ Ask a Question
- ▶ Application Help
- ▶ Request a Sample
- ▶ Request a Catalog

## COMMERCIAL-GRADE GEARTOOTH SPEED SENSORS

Commercial-grade, Hall effect geartooth speed sensor with adjustable aluminum housing.

- Sense Motion of Ferrous Geartooth Targets
- Near-Zero Speed Sensing Capability
- Immune to Hostile Environments
- Not Subject to Rotational Orientation
- High-Speed Capability
- Operate from 5 to 24Vdc
- Reverse Battery Protection to 24Vdc
- Wide Operating and Storage Temperature Range

### GS1005 - 1009



download PDF

Search Site

Check Distributor Stock

### GS1005 - 1009 SPECIFICATIONS

Part #	Operating Voltage Range (VDC)	Supply Current mA max	Output	Output Voltage mV max	Output Current mA max	Operate Temp Range, C	Storage Temp Range, C	Housing	Thread	Barrel Length	Leads	Connector
GS100501	4.5 to 24	6	sink	400	25	-40 to 105	-40 to 105	Alum. (red)	M12-1	65mm		12mm circular
GS100502	4.5 to 24	6	sink	400	25	-40 to 125	-40 to 125	Alum. (red)	M12-1	65mm	20 AWG x 1m BBB	
GS100601	4.5 to 24	6	sink	400	25	-40 to 105	-40 to 105	Alum. (red)	M18-1	65mm		12mm circular
GS100602	4.5 to 24	6	sink	400	25	-40 to 125	-40 to 125	Alum. (red)	M18-1	65mm	20 AWG x 1m BBB	
GS100701	4.5 to 24	6	sink	400	25	-40 to 125	-40 to 125	Alum. (black)	15/32" - 32	1.00"	20 AWG x 1m BBB	
GS100801	4.5 to 24	6	sink	400	25	-40 to 105	-40 to 105	Alum. (black)	5/8" - 18	2.56"		12mm circular
GS100802	4.5 to 24	6	sink	400	25	-40 to 125	-40 to 125	Alum. (black)	5/8" - 18	2.56"	20 AWG x 1m BBB	
GS100901	4.5 to 24	6	sink	400	25	-40 to 105	-40 to 105	Alum. (black)	3/4" - 16	2.56"		12mm circular
GS100902	4.5 to 24	6	sink	400	25	-40 to 125	-40 to 125	Alum. (black)	3/4" - 16	2.56"	20 AWG x 1m BBB	

Notes: For sensors with integral connectors, mating cordsets are available from Cherry. Request Part Number AS000203 for a straight female connector or AS000204 for a right-angle female connector.

### OPEN COLLECTOR SINKING BLOCK DIAGRAM

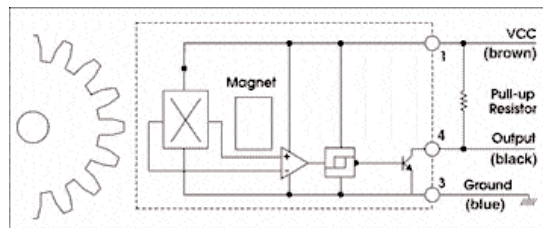

### DIMENSIONS

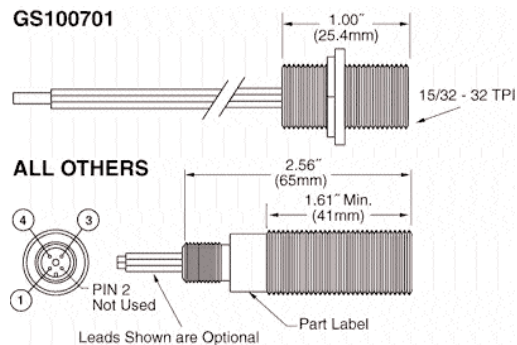

# Mouser Electronics

Authorized Distributor

Click to View Pricing, Inventory, Delivery & Lifecycle Information:

[CHERRY:](#)

[GS100502](#) [GS100701](#)