

Description

All 19" cassette style converters are equipped with either H11, H15, H15S4, or H15S2 male connectors. Mating female connectors are available as accessories. The four H-type connector versions are especially designed for power supply applications, capable of handling high operating currents. The connectors have an integrated code key system allowing many coding possibilities. Converters with high output current normally use two contacts in parallel to keep the voltage drop across the connector as low as possible. In case of very high currents, the connectors are fitted with round high current contacts.

Note: Parts ending with -G are RoHS-compliant for all 6 substances.

H11 Connectors

This connector has 11 contacts in one vertical column marked 2 to 32. Mating and mounting conditions are according to IEC 60603-2 and DIN 41612. The connector contacts are hard-silver plated and correspond to quality class 1, allowing for 500 mating cycles.

Note: H11 connectors (male version) are used in the converter series (case size): H (H02), M (M02), and PSL (L04).

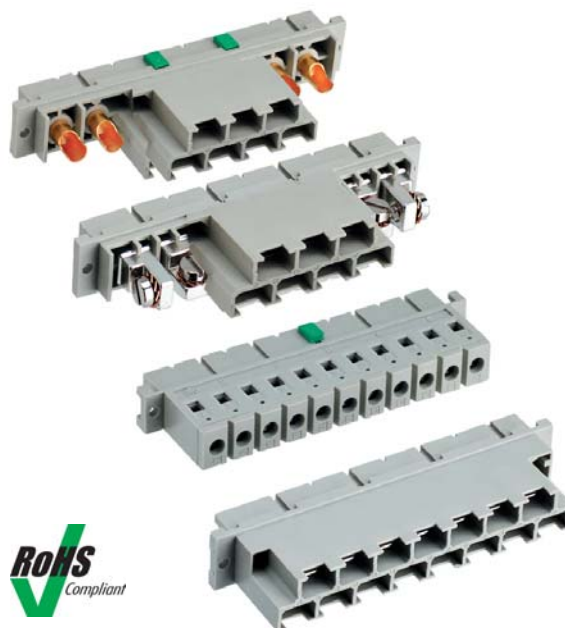

Table 1: H11 Connector Survey

Female connector (former designation)	Part number	Description of terminals	Fig.	Integrated coding
STV-H11-F/CO	HZZ00101-G	Faston terminals 6.3 × 0.8 mm	2	yes
STV-H11-FG/CO ²	HZZ00196 ²	Faston terminals 6.3 × 0.8 mm, gold-plated contacts	2	yes
STV-H11-FS/CO-G	HZZ00104-G	Faston terminals 6.3 × 0.8 mm, solderable (short moulding)	3	yes
STV-H11-FSR/CO-G ⁴	HZZ00102-G ⁴	Screw terminals, 90°, 2.5 mm ² (AWG 13), torque ≤ 26.6 Ncm	4	yes
STV-H11-FB/CO-G ¹	HZZ00103-G ¹	Solder pin 5.2 mm, Ø 1.6 mm	5	yes
STV-H11-FBG/CO ³	HZZ00199 ³	Solder pin 5.2 mm, Ø 1.6 mm, gold-plated contacts	5	yes
STV-H11-FBER/CO ³	HZZ00113 ³	Solder pin 4.3 mm, Ø 1.0 mm	5	yes
STV-H11-FP/CO	HZZ00111-G	Press fit 6.5 mm, Ø 1.0 mm	5	yes

¹ See also matching Flexi-PCB (HZZ01208-G) for PCB-mounting of converters, fig. 6.

² Obsolete; use HZZ00101-G

³ Obsolete; use HZZ00103-G (STV-H11-FB/CO-G)!

⁴ Obsolete; use connectors with faston terminals!

Obsolete parts

Preferred for new designs

Mechanical Dimensions (in mm)

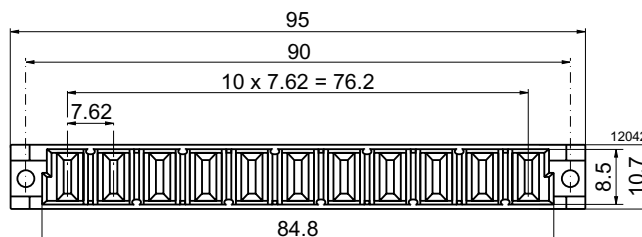

Fig. 1
H11 front view, relating to figures 2 to 5

Table of Contents

	Page		Page
Description	1	Code Key System	8
H11 Connectors	1	Connector Retention Clips	9
H15 Connectors	3	Connector Retention Brackets CRB	9
H15S4, H15S2 Connectors	6	Cable Hood	10
Technical Data	8	Cage Clamp Adapter	10

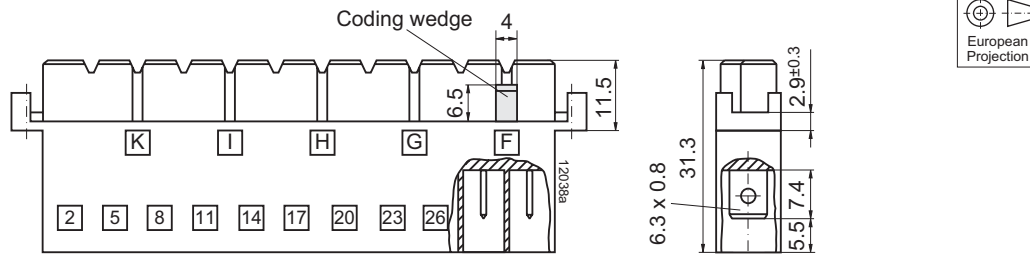

Fig. 2
HZZ00101-G (STV-H11-F/CO), faston terminals 6.3×0.8 mm
HZZ00196 (STV-H11-FG/CO), faston terminals 6.3×0.8 mm with gold plated contacts, **obsolete**

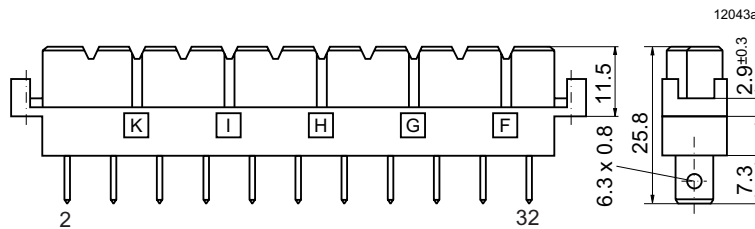

Fig. 3
HZZ00104-G (STV-H11-FS/CO),
faston terminals 6.3×0.8 mm, solderable (short moulding)

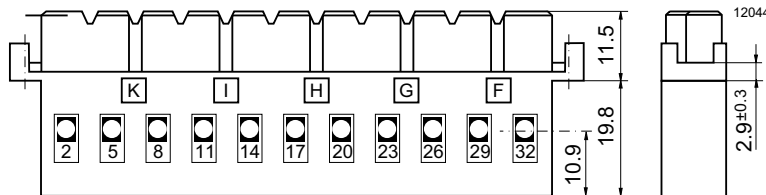

Fig. 4
HZZ00102-G (STV-H11-FSR/CO), screw terminals,
max. 2.6 mm^2 (AWG 13), max torque 26.6 Ncm.

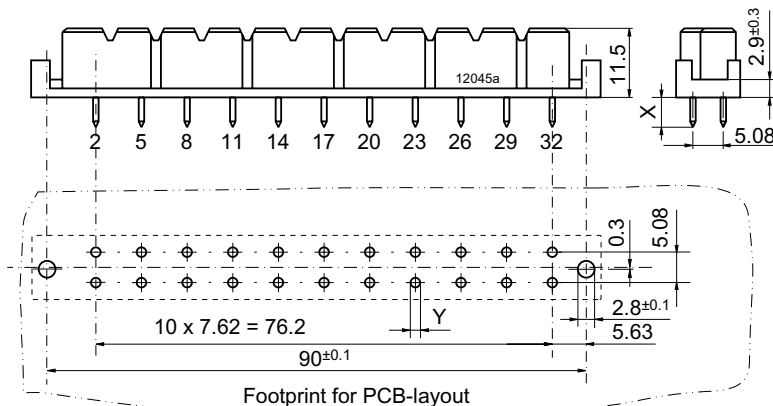

Fig. 5
HZZ00103-G (STV-H11-FB/CO), solder pins, $X = 5.2$, $Y = \varnothing 1.6$
HZZ00199 (STV-H11-FBG/CO), solder pins, $X = 5.2$, $Y = \varnothing 1.6$, **obsolete**
HZZ00113 (STV-H11-FBER/CO), solder pins, $X = 4.3$, $Y = \varnothing 1.0$, **obsolete**
HZZ00111-G (STV-H11-FP/CO), press insert pins, $X = 6.5$, $Y = \varnothing 1.0$

Flexible H11 PCB

If cassette style converters with H11 male connectors are mounted on a PCB board, the connection can be made

using the H11 flexible PCB (fig. 6) together with the female connector HZZ00103-G (STV-H11-FB/CO-G).

Part number: HZZ01208-G

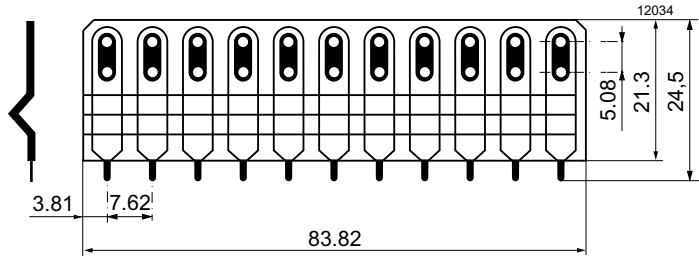
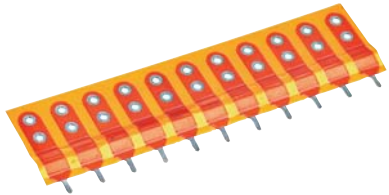

Fig. 6
Flexible H11 flexible PCB board HZZ01208-G

H15 Connectors

This connector has 15 contacts in two vertical columns, marked with 4 to 32 and is designed to meet DIN 41612. The connector contacts are hard-silver plated and correspond to

quality class 1, allowing for 500 mating cycles.

Note: This connector type (male version) is used in the following converter series (case size): Q, P, LPC, PSK, PSS, K, S, T.

Table 2: H15 Connector Survey

Female connector former designation	Part number	Description of terminals	Fig.	Integrated coding
STV-H15-FSR-G ²	HZZ00107-G ²	Screw terminals, 90°, 2.5 mm ² (AWG 13), torque ≤ 26.6 Ncm	8	no
STV-H15-F/CO-G	HZZ00106-G	Faston terminals 6.3 × 0.8 mm	(8)	yes
STV-H15-FB/CO	HZZ00112-G	Solder pin 4.0 mm, Ø 1.6 mm	9a	yes
STV-H15-FBG/CO ¹	HZZ00197 ¹	Solder pin 4.0 mm, Ø 1.6 mm, gold-plated contacts	9a	yes
STV-H15-FWS/CO	HZZ00114-G	Solder pin 10.1 mm, Ø 1.6 mm, 90° bent contacts	9b	yes
STV-H15-FP/CO	HZZ00117-G	Press fit 4.5 mm, square 0.6 mm (double-pin version)	9c	yes
H 15 cage clamp	HZZ00118-G	Cage clamp contacts, wire gauge Ø 0.14 – 1.5 mm	10	no

¹ Obsolete; use HZZ00112-G !

² Temporarily unavailable; can be replaced by HZZ00118-G.

Obsolete parts

Preferred for new designs

Mechanical Dimensions (in mm)

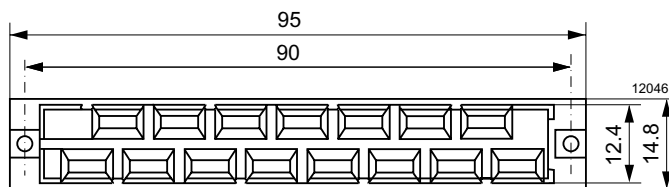

Fig. 7
H15 front view, relating to the next figures

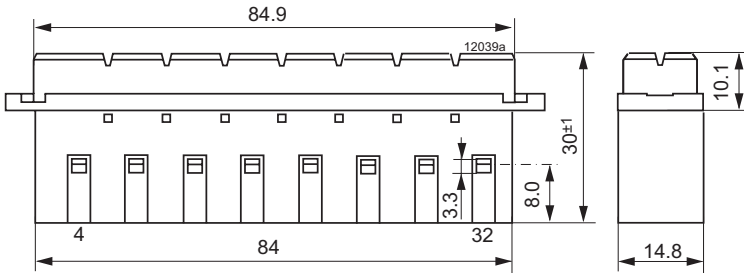

Fig. 8
HZZ00107-G (STV-H15-FSR-G),
screw terminals, no coding, max torque 26.6 Ncm
HZZ00106-G (STV-H15-F/CO-G),
Faston terminals 6.3 × 0.8 mm (identical
dimensions, but not shown). The orientation of
the faston terminals can be horizontal or
vertical, depending on supplier.

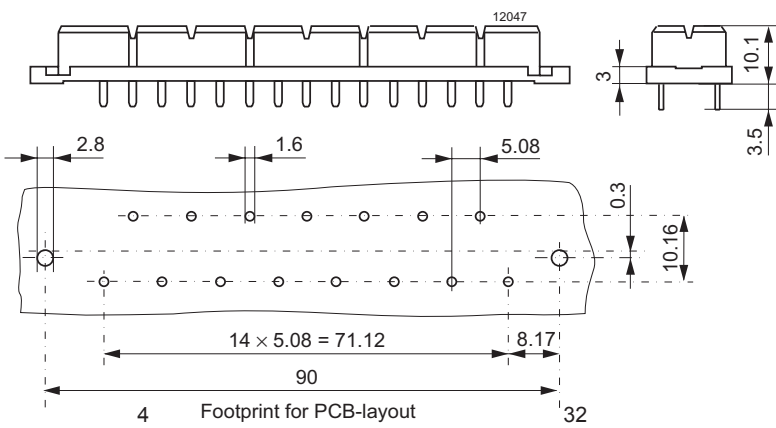

Fig. 9a
HZZ00112-G (STV-H15-FB/CO),
solder pins, foot print.

HZZ00197 (STV-H15-FBG/CO),
solder pins, foot print, **obsolete**

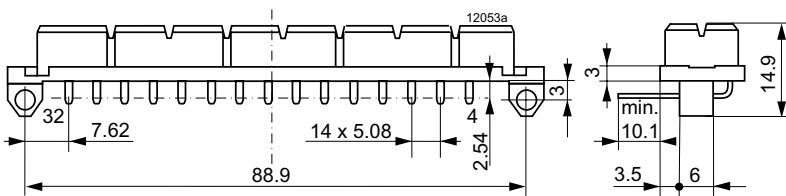

Fig. 9b
HZZ00114-G (STV-H15-FWS/CO),
solder pins for PCB mounting

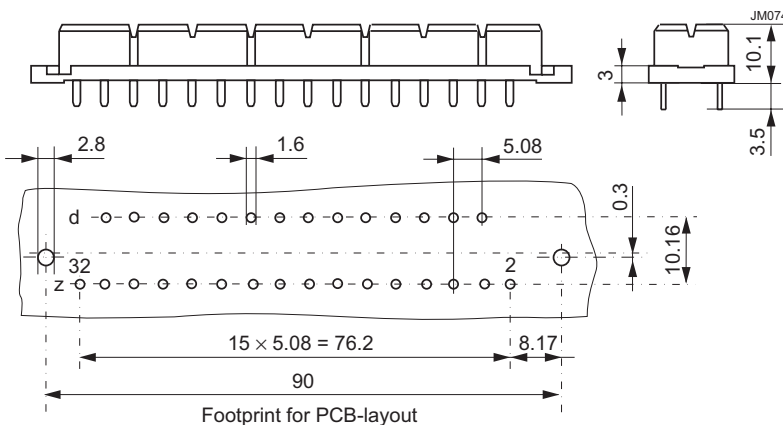

Fig. 9c
HZZ00117-G (STV-H15-FP/CO),
press fit pins, foot print



View X

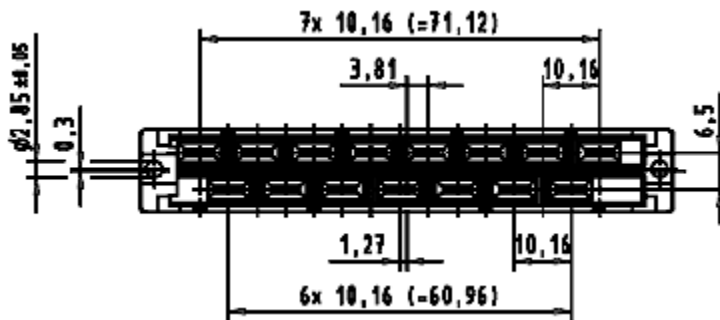
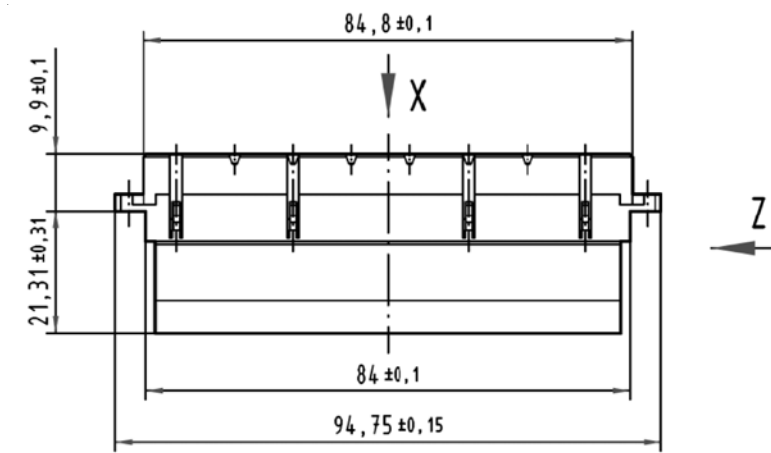
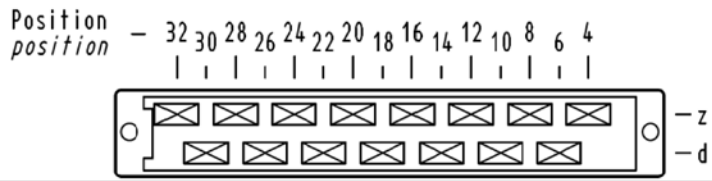

Fig. 10
HZZ00118-G,
cage clamp connector,
wire gauge \varnothing 0.14 – 1.5 mm

H15S4, H15S2 Connectors

These special connectors derive from the H15 connectors having standard contacts like the standard connectors, combined with 4 (H15S4) or 2 (H15S2) high-current contacts (jacks) according to DIN 41626. These jacks are specially designed to handle currents up to 40 A. They correspond to quality class 2, allowing for 400 mating cycles. The contact material is high-quality Phosphor Bronze.

The high-current jacks are joined separately to the connectors. To install them, carefully follow the assembly instructions. It is extremely important to solder cables, screw cable terminals or heat shrink sleeves to high-current jacks first, before inserting them into the moulding. Paralleled converters should preferably be interconnected on current bars or at a star point.

Using screw versions, the two outer high-current jacks may be inserted at a 90° angle in order to prevent possible short

circuits between the cable terminals, especially in applications with high vibration environment. Heat shrink sleeves might be necessary for further isolation purposes or to keep clearances and creepage distances at specified levels.

An extraction tool allows removal of the high-current jacks for replacement (see fig. 18).

Caution: The use of an adequate cable strain relief device (e.g. Cable Hood etc.) is essential, in order to protect the high-current contact jacks from damage. Do not screw, solder or manipulate these contacts, when the connector is plugged into the male connector! The use of highly flexible cables is strongly recommended.

Note: H15S4 connectors (male version) are used in the following converter series (case size): K, PSK with line currents ≥ 20 A.

Note: H15S2 connectors (male version) are used in the following converter series (case size): P1000, K4000 with line currents ≥ 20 A. H15S2 connectors are not for new designs. Please consult the product data sheets for replacing models.

Table 3: H15S2 and H15S4 connector survey

Female connector former designation	Part number	Description of terminals	Fig.	Integrated coding
STV-H15S2-FSF/CO ³	HZZ00116 ³	11 faston terminals 6.3 × 0.8 mm, 2 screw jacks ¹	12 + 11b	yes
STV-H15S2-F/CO ³	HZZ00115 ³	11 faston terminals 6.3 × 0.8 mm, 2 solder jacks ¹	(12) + 11a	yes
STV-H15S4-FSF/CO	HZZ00110-G	7 faston terminals 6.3 × 0.8 mm, 4 screw jacks ¹	14	yes
STV-H15S4-F/CO	HZZ00105-G	7 faston terminals 6.3 × 0.8 mm, 4 solder jacks ¹	(14)	yes
STV-H15S4-FLS/CO ²	HZZ00109	7 screw terminals 90°, 2.5 mm ² , torque ≤ 26.6 Ncm, 4 solder jacks ¹	15	yes
STV-H15S4-FSR/CO ²	HZZ00108	7 screw terminals, 90°, 2.5 mm ² , torque ≤ 26.6 Ncm, 4 screw jacks ¹	(15)	yes

¹ Spare jacks are available on request: screw version YVM002-G, solder version XMB045; see fig. 11a and 11b.

² Obsolete; use female connectors with faston terminals instead!

³ H15S2 connectors are not for new designs.

Delivery content: H15S4 (S2) moulding, 4 (2) high current jacks and assembly instructions. Screw versions also include four M4 screws with washers and heat shrink sleeves.

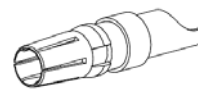

Fig. 11a
Solder jack XMB045

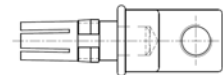

Fig. 11b
Screw jack YVM002-G
for screws M4.

Mechanical Dimensions (in mm)

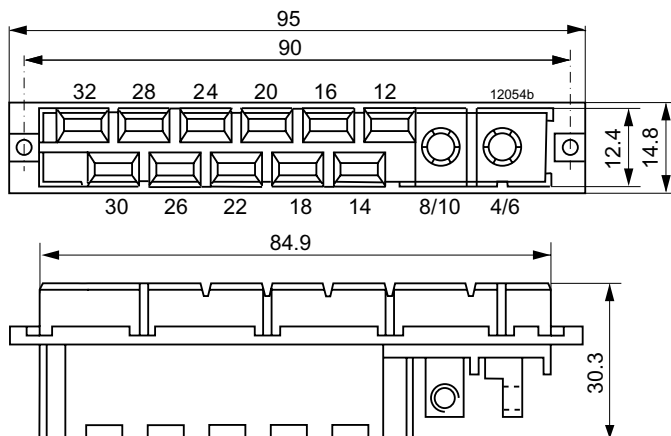

Fig. 12
HZZ00116 (STV-H15 S2-FSF/CO)
11 faston terminals and two screw jacks.
HZZ00115 (STV-H15 S2-F/CO)
11 faston terminals and two solder jacks
(solder jacks are shown in fig. 15).

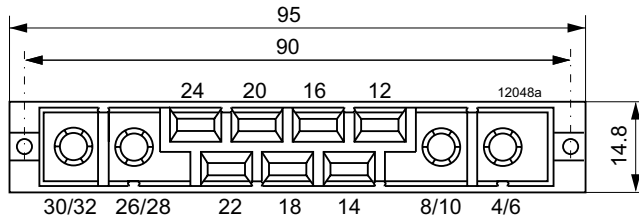

Fig. 13
H15S4 front view, relating to figures below

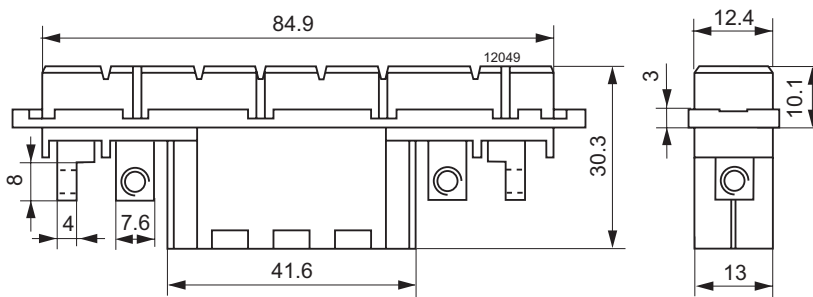

Fig. 14
HZZ00110-G (STV-H15 S4-FSF/CO),
7 faston terminals and 4 screw jacks
HZZ00105-G (STV-H15 S4-F/CO),
7 faston terminals and 4 solder jacks (solder jacks, fig. 11a, are shown in fig. 15)

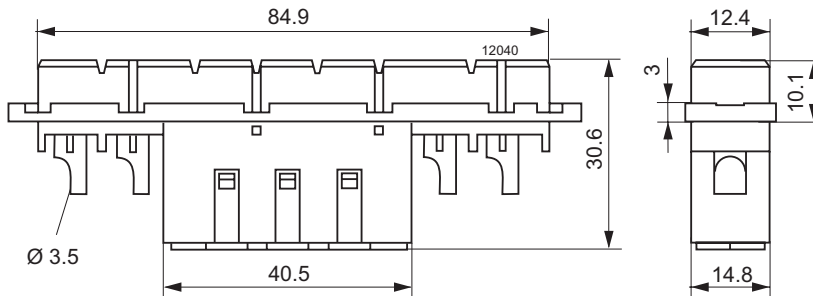

Fig. 15
HZZ00109 (STV-H15 S4-FLS/CO), **obsolete**,
7 screw terminals (max torque 26.6 Ncm) and 4 solder jacks
HZZ00108 (STV-H15 S4-FSR/CO), **obsolete**,
7 screw terminals (max torque 26.6 Ncm) and 4 screw jacks (screw jacks, fig. 11b, are shown in fig. 14)

The connectors shown in fig. 15 with 7 screw terminals are obsolete. Use connectors with 7 faston terminals instead, HZZ00110-G or HZZ00105-G; see fig. 14.

Extraction Tool for High Current Contacts

High current plugs and jacks can be disassembled from the moulding by means of a special extraction tool (H15S2 and H15S4 connectors). Holding the extraction tool over the center of the connector's female contact the outer part of the extraction tool should be fed between the moulding and the outside of the female contact itself. This releases the spring clip fixing the contacts, in order to pull the contacts out of their moulding for replacement. If the operation is performed correctly, very little force is required. Extreme care should be taken since incorrect procedure and excessive force could damage the tool and/or the connector.

This tool is available as an accessory for high-current solder and high-current screw contacts.

Note: In order to avoid damage, never manipulate high-current contacts when plugged-in!

Part number: HZZ00150-G
Description: Extraction tool



Fig. 16
Extraction tool HZZ00150-G

Technical Data of Connectors

Table 4: Connector data

Mechanical data	H11	H15	H15S2 / H15S4	
			Fastons	High current
Number of poles	11	15	11/7	2/4
Mating cycles	500	500	400	
Insertion/withdrawal forces max.	80 N	90 N	90 N	10/1.6 N
Electrical data				
Clearances and creepage distances contact to ground	≥ 4.5 mm	≥ 4.5 mm	≥ 4.0 mm	
Clearances and creepage distances between contacts	≥ 8.0 mm	≥ 8.0 mm	≥ 4.0 mm	
Test voltage	3100 VAC	3100 VAC	3100 VAC	
Operation voltage	500 VAC	500 VAC	500 VAC	
Operation current per contact	$T_A = 20\text{ °C}$ 20 A $T_A = 70\text{ °C}$ 17 A $T_A = 95\text{ °C}$ 14 A	15 A 12 A 9 A	15 A 12 A 9 A	40 A 35 A 25 A
Contact resistance	≤ 8 mΩ	≤ 8 mΩ	≤ 8 mΩ	≤ 1 mΩ
Insulation resistance at 100 VDC	≥ 1000 MΩ	≥ 1000 MΩ	≥ 1000 MΩ	
Miscellaneous data				
Operating temperature	-55 to 125 °C	-55 to 125 °C	-55 to 105 °C	
Contact surface	6 μ Ag	6 μ Ag	6 μ Ag over 2 μ Ni	0.8 μ Au over 2 μ Ni
Moulding material of the female connector (not all models)	PBTP black Crastin SK645FR (E41938)	Arnite TV4 264 SN (E47960)	Lyquid Cristal Polymer, Vectra E130i (former material: Glass filled PBT)	
Flammability	UL 94 V-0/UL 94 V-1	UL 94 V-0/UL 94 V-1	UL 94 V-0	

Code Key System

An efficient coding system is of great importance in complex electronic systems. Since power supplies handle high currents and voltages, any false connection could be dangerous and quite costly.

This integrated polarizing system allows effortless coding by the simple insertion of coding wedges (HZZ00202-G) into the female connector mouldings. The corresponding counter-

parts, i.e. the coding tabs of the male moulding, just have to be broken off to match the right female part. Major advantages are high mechanical stability and easy handling. The H11 connectors have 10 and the H15 connectors 8 coding positions. The use of coding wedges allows for many different coding possibilities. Coding wedges are available as accessories to female connectors with the following item number (fig. 17):

Part number: HZZ00202-G
Description: Codierkeil XKN031-G
Delivery content: 5 pcs.



Fig. 17
Integrated code key system for a H11 connector

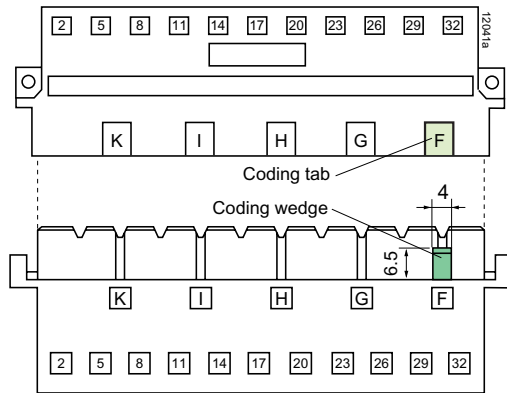

Bottom side: A B C D E

Fig. 18
Integrated code key system (H11 connector)

Connector Retention Clips

The retention clip V is an accessory, which guarantees secure connection even under severe vibration, as for example in mobile applications. One connector retention system fits to almost all converters and all of the mentioned connector types.

The following converter series are delivered with pre-punched holes in the back plate for fast field-mounting of retention clips:

Note: Suitable for H, M, K, S, PSK, PSS, PSL, R, and T Series.
Q, P, LPC Series only in combination with HZZ01215-G (Mounting Plate Q)

Part number: HZZ01209-G
Description: Retentionclip (2x)
Delivery content: 2 pcs. in a plastic beg

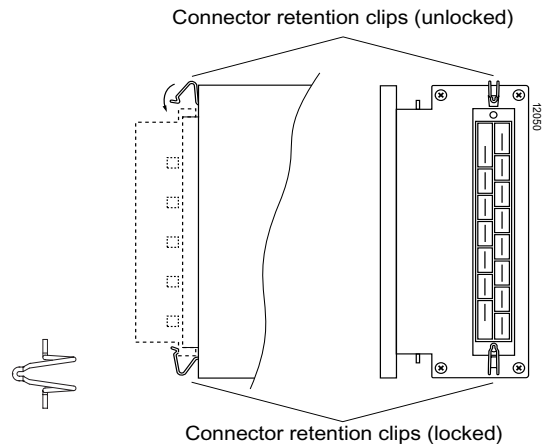

Fig. 19
Connector retention clips HZZ01209-G and their application

Connector Retention Brackets

An alternative to the above mentioned retention clip V is the connector retention bracket. They are attached to the back plate by one screw each with a torque of 20 to 30 Ncm.

Table 5: Connector Retention Bracket Survey

Series	Part number Description	Delivery content
K, R, S PSK, PSS, PSL H, M, T	HZZ01216-G CRB-HKMS	2 brackets 2 screws 2 washers in a beg
Q, P LPC	HZZ01217-G CRB-Q	



Fig. 20
Connector retention brackets HZZ01216-G (left-hand side)
and HZZ01217-G (right-hand side)

Cable Hood

A cable connector housing (cable hood) is available for all female H15, H15S2, and H15S4 type connectors with faston terminals (not suitable for screw terminals). It serves as a strain relief, isolates connections and protects cables.

Part number: HZZ00141-G
Description: Cable hood for H15, H15S2, H15S4
Delivery content: Connector housing, blanc label

for K, S, R, T, PSK, PSS Series converters, the cable hood can be fixed to the converter case with a pair of U-shaped cable hood retention brackets; see fig. 21.



Fig. 21
Cable hood HZZ00141-G fixed with retention brackets HZZ01218-G

Part number: HZZ01218-G
Description: Retention brackets CHRB-KSG
Delivery content: 2 brackets XMK187-G
2 screws XMM003-G (M2.5 x 6)
Install. instruction BZM20006, blank label.

For fixing the cable hood with a pair of retention clips HZZ01209-G, a special version HZZ00142-G is available where both sides of the cable hood are slightly modified in order to allow for insertion of the clips. The cable hood fixed with the clips has been tested to withstand vibrations according to IEC/EN 60068-2-6: 5 g, 7.5 h (2.5 h per axis). See fig. 22.

Part number: HZZ00142-G
Description: Cable hood for H15/H15S2/S4
Delivery content: Connector housing, blanc label

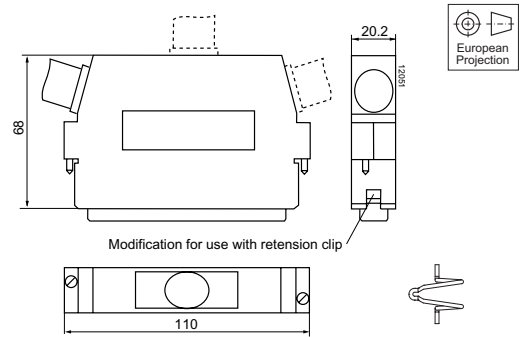

Fig. 22
Cable hood HZZ00142-G for fastening with retention clips HZZ01209-G

A **metallic version** of the cable hood provides fire protection; see fig. 23

Part number: HZZ00143-G
Description: Metallic cable hood for H15/H15S2/S4
Delivery content: Connector housing, blanc label



Fig. 23
Metallic cable hood HZZ00143-G providing fire protection

Cage Clamp Adapter

The adapter HZZ00144-G allows for connecting a converter with cage clamp technique; see fig. 24.

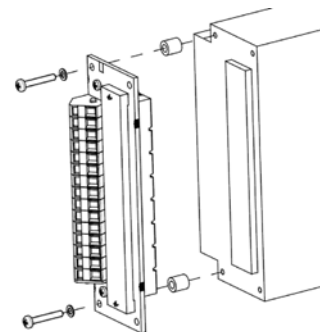

Fig. 24
Cage clamp adapter HZZ00144-G

NUCLEAR AND MEDICAL APPLICATIONS - Power-One products are not designed, intended for use in, or authorized for use as critical components in life support systems, equipment used in hazardous environments, or nuclear control systems without the express written consent of the respective divisional president of Power-One, Inc.

TECHNICAL REVISIONS - The appearance of products, including safety agency certifications pictured on labels, may change depending on the date manufactured. Specifications are subject to change without notice.