

4M x 4-Bit Dynamic RAM 2k & 4k-Refresh (Hyper Page Mode- EDO)

HYB 5116405BJ -50/-60/-70
HYB 5117405BJ -50/-60/-70

Advanced Information

- 4 194 304 words by 4-bit organization
- 0 to 70 °C operating temperature
- Performance:

		-50	-60	-70	
t_{RAC}	\overline{RAS} access time	50	60	70	ns
t_{CAC}	\overline{CAS} access time	13	15	20	ns
t_{AA}	Access time from address	25	30	35	ns
t_{RC}	Read/Write cycle time	84	104	124	ns
t_{HPC}	Hyper page mode (EDO) cycle time	20	25	30	ns

- Single + 5 V ($\pm 10\%$) supply
- Low power dissipation
 - max. 550 mW active (HYB 5116405BJ-50)
 - max. 495 mW active (HYB 5116405BJ-60)
 - max. 440 mW active (HYB 5116405BJ-70)
 - max. 660 mW active (HYB 5117405BJ-50)
 - max. 605 mW active (HYB 5117405BJ-60)
 - max. 550 mW active (HYB 5117405BJ-70)
 - 11 mW standby (TTL)
 - 5.5 mW standby (MOS)
- Output unlatched at cycle end allows two-dimensional chip selection
- Read, write, read-modify-write, \overline{CAS} -before- \overline{RAS} refresh, \overline{RAS} -only refresh, hidden refresh, self refresh and test mode
- Hyper page mode (EDO) capability
- All inputs, outputs and clocks fully TTL-compatible
- 4096 refresh cycles / 64 ms for HYB 5116405BJ/BT (4k-Refresh)
- 2048 refresh cycles / 32 ms for HYB 5117405BJ/BT (2k-Refresh)
- Plastic Package: P-SOJ-26/24 (300 mil)

The HYB 5116(7)405BJ is a 16 MBit dynamic RAM organized as 4194304 words by 4-bits. The HYB 5116(7)405BJ utilizes a submicron CMOS silicon gate process technology, as well as advanced circuit techniques to provide wide operating margins, both internally and for the system user. Multiplexed address inputs permit the HYB 5116(7)405BJ to be packaged in a standard SOJ 26/24 plastic package with 300 mil width. These package provides high system bit densities and are compatible with commonly used automatic testing and insertion equipment. System-oriented features include single + 5 V ($\pm 10\%$) power supply, direct interfacing with high-performance logic device families such as Schottky TTL.

Ordering Information

Type	Ordering Code	Package	Descriptions
HYB 5116405BJ-50	Q67100-Q1098	P-SOJ-26/24 300 mil	DRAM (access time 50 ns)
HYB 5116405BJ-60	Q67100-Q1099	P-SOJ-26/24 300 mil	DRAM (access time 60 ns)
HYB 5116405BJ-70	Q67100-Q1100	P-SOJ-26/24 300 mil	DRAM (access time 70 ns)
HYB 5117405BJ-50	Q67100-Q1101	P-SOJ-26/24 300 mil	DRAM (access time 50 ns)
HYB 5117405BJ-60	Q67100-Q1102	P-SOJ-26/24 300 mil	DRAM (access time 60 ns)
HYB 5117405BJ-70	Q67100-Q1103	P-SOJ-26/24 300 mil	DRAM (access time 70 ns)

Pin Names

A0-A11	Row Address Inputs for HYB 5116405
A0-A9	Column Address Inputs for HYB 5116405
A0-A10	Row and Column Address Inputs for HYB 5117405
$\overline{\text{RAS}}$	Row Address Strobe
$\overline{\text{OE}}$	Output Enable
I/O1-I/O4	Data Input/Output
$\overline{\text{CAS}}$	Column Address Strobe
$\overline{\text{WE}}$	Read/Write Input
V_{CC}	Power Supply (+ 5 V)
V_{SS}	Ground (0 V)
N.C.	Not connected

Pin Configuration (top view)

P-SOJ-26/24 300 mil

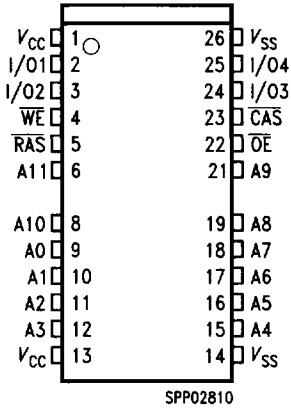

HYB 5116405 BJ

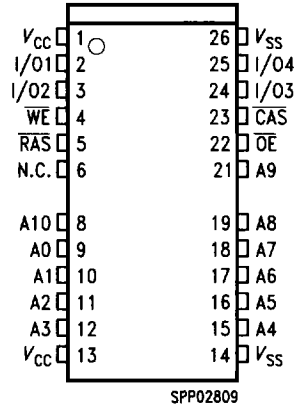

HYB 5117405 BJ

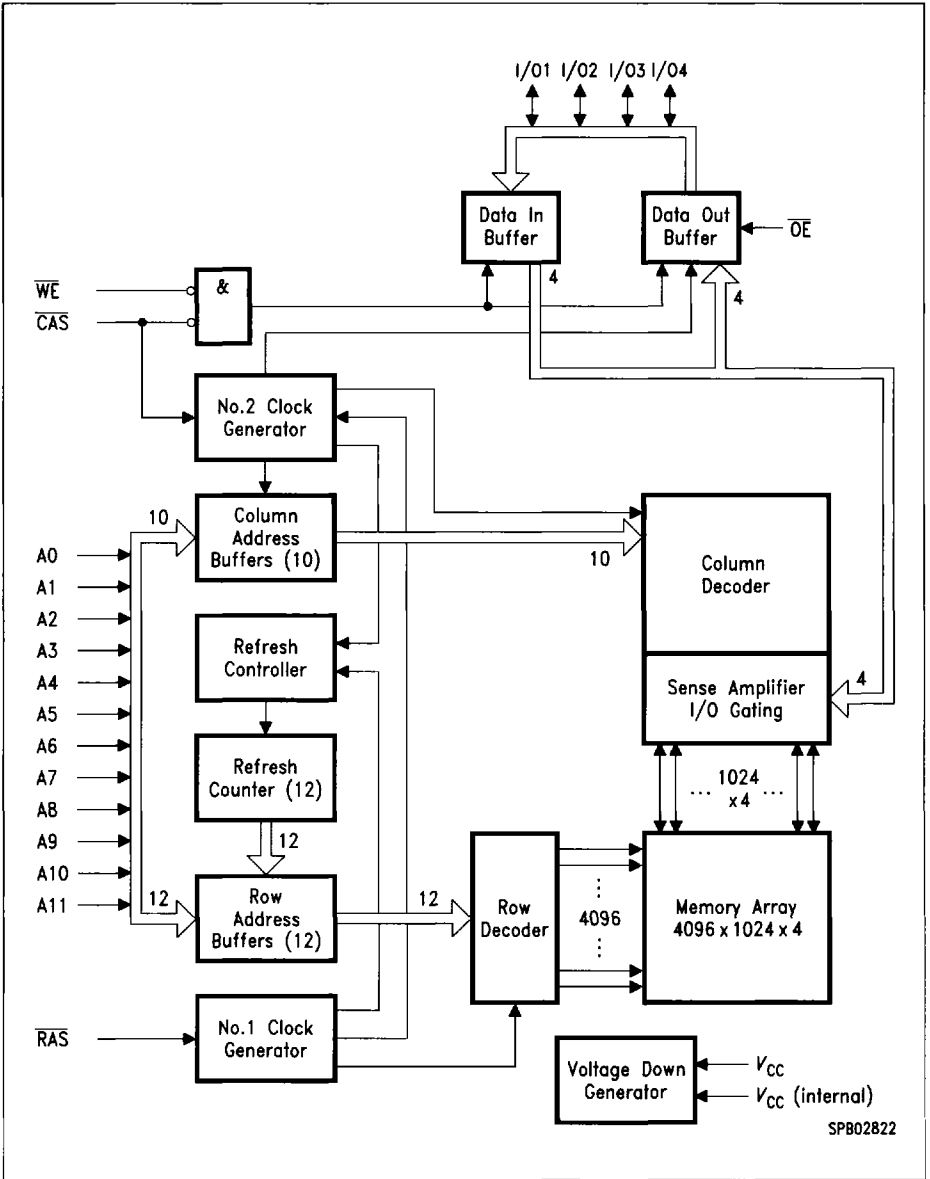

SPB02822

Block Diagram for HYB 5116405

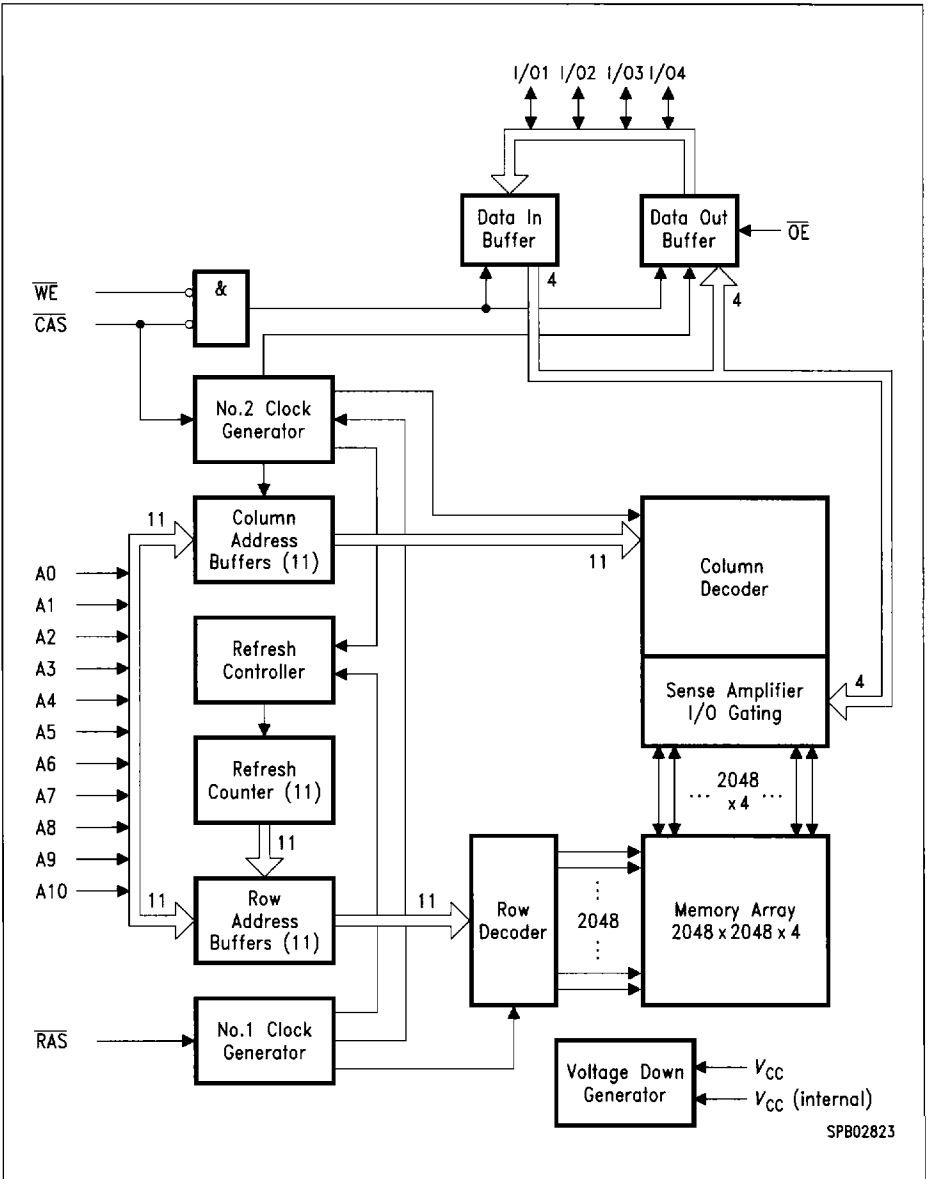

SPB02823

Block Diagram for HYB 5117405

Absolute Maximum Ratings

Operating temperature range	0 to 70 °C
Storage temperature range.....	- 55 to 150 °C
Input/output voltage	- 0.5 to min ($V_{CC} + 0.5, 7.0$) V
Power supply voltage.....	- 1.0 V to 7.0 V
Power dissipation.....	1.0 W
Data out current (short circuit)	50 mA

Note: Stresses above those listed under "Absolute Maximum Ratings" may cause permanent damage of the device. Exposure to absolute maximum rating conditions for extended periods may affect device reliability.

DC Characteristics (note: values in brackets for HYB 5117405 BJ)

$T_A = 0$ to 70 °C, $V_{SS} = 0$ V, $V_{CC} = 5$ V \pm 10 %; $t_T = 2$ ns

Parameter	Symbol	Limit Values		Unit	Test Condition
		min.	max.		
Input high voltage	V_{IH}	2.4	$V_{CC} + 0.5$	V	1)
Input low voltage	V_{IL}	- 0.5	0.8	V	1)
Output high voltage ($I_{OUT} = - 5$ mA)	V_{OH}	2.4	-	V	1)
Output low voltage ($I_{OUT} = 4.2$ mA)	V_{OL}	-	0.4	V	1)
Input leakage current (0 V $\leq V_{IH} \leq V_{CC} + 0.3$ V, all other pins = 0 V)	$I_{(L)}$	- 10	10	μ A	1)
Output leakage current (DO is disabled, 0 V $\leq V_{OUT} \leq V_{CC} + 0.3$ V)	$I_{O(L)}$	- 10	10	μ A	1)
Average V_{CC} supply current: -50 ns version -60 ns version -70 ns version (\overline{RAS} , \overline{CAS} , address cycling: $t_{RC} = t_{RC}$ min.)	I_{CC1}	-	100(120) 90 (110) 80 (100)	mA mA mA	2) 3) 4) 2) 3) 4) 2) 3) 4)
Standby V_{CC} supply current ($\overline{RAS} = \overline{CAS} = V_{IH}$)	I_{CC2}	-	2	mA	-
Average V_{CC} supply current, during \overline{RAS} -only refresh cycles: -50 ns version -60 ns version -70 ns version (\overline{RAS} cycling, $\overline{CAS} = V_{IH}$, $t_{RC} = t_{RC}$ min.)	I_{CC3}	-	100(120) 90 (110) 80 (100)	mA mA mA	2) 4) 2) 4) 2) 4)
Average V_{CC} supply current, during hyper page mode: -50 ns version -60 ns version -70 ns version ($\overline{RAS} = V_{IL}$, \overline{CAS} , address cycling: $t_{PC} = t_{PC}$ min.)	I_{CC4}	-	70 (70) 55 (55) 45 (45)	mA mA mA	2) 3) 4) 2) 3) 4) 2) 3) 4)

DC Characteristics (note: values in brackets for HYB 5117405 BJ) (cont'd)

$T_A = 0$ to 70 °C, $V_{SS} = 0$ V, $V_{CC} = 5$ V \pm 10 %; $t_T = 2$ ns

Parameter	Symbol	Limit Values		Unit	Test Condition
		min.	max.		
Standby V_{CC} supply current ($\overline{RAS} = \overline{CAS} = V_{CC} - 0.2$ V)	I_{CC5}	–	1	mA	1)
Average V_{CC} supply current, during \overline{CAS} -before-RAS refresh mode: -50 ns version -60 ns version -70 ns version (\overline{RAS} , \overline{CAS} cycling: $t_{RC} = t_{RC}$ min.)	I_{CC6}	– – –	100(120) 90 (110) 80 (100)	mA mA mA	2) 4) 2) 4) 2) 4)
Average Self Refresh Current (CBR cycle with $t_{RAS} > t_{RASS}$ min., \overline{CAS} held low, $\overline{WE} = V_{CC} - 0.2$ V, Address and $Din = V_{CC} - 0.2$ V or 0.2 V)	I_{CC7}	–	1	mA	

Capacitance

$T_A = 0$ to 70 °C, $V_{CC} = 5$ V \pm 10 %, $f = 1$ MHz

Parameter	Symbol	Limit Values		Unit
		min.	max.	
Input capacitance (A0 to A10, A11)	C_{i1}	–	5	pF
Input capacitance (\overline{RAS} , \overline{CAS} , \overline{WE} , \overline{OE})	C_{i2}	–	7	pF
I/O capacitance (I/O1-I/O4)	C_{i0}	–	7	pF

AC Characteristics ⁵⁾⁶⁾

$T_A = 0$ to 70 °C, $V_{CC} = 5$ V \pm 10 %, $t_T = 2$ ns

16E

Parameter	Symbol	Limit Values						Unit	Note
		-50		-60		-70			
		min.	max.	min.	max.	min.	max.		

Common Parameters

Random read or write cycle time	t_{RC}	84	–	104	–	124	–	ns	
\overline{RAS} precharge time	t_{RP}	30	–	40	–	50	–	ns	
\overline{RAS} pulse width	t_{RAS}	50	10k	60	10k	70	10k	ns	
\overline{CAS} pulse width	t_{CAS}	8	10k	10	10k	12	10k	ns	
Row address setup time	t_{ASR}	0	–	0	–	0	–	ns	
Row address hold time	t_{RAH}	8	–	10	–	10	–	ns	
Column address setup time	t_{ASC}	0	–	0	–	0	–	ns	
Column address hold time	t_{CAH}	8	–	10	–	12	–	ns	
\overline{RAS} to \overline{CAS} delay time	t_{RCD}	12	37	14	45	14	53	ns	
\overline{RAS} to column address delay	t_{RAD}	10	25	12	30	12	35	ns	
\overline{RAS} hold time	t_{RSH}	13	–	15	–	17	–	ns	
\overline{CAS} hold time	t_{CSH}	40	–	50	–	60	–	ns	
\overline{CAS} to \overline{RAS} precharge time	t_{CRP}	5	–	5	–	5	–	ns	
Transition time (rise and fall)	t_T	1	50	1	50	1	50	ns	7
Refresh period for HYB5116405	t_{REF}	–	64	–	64	–	64	ms	
Refresh period for HYB5117405	t_{REF}	–	32	–	32	–	32	ms	

Read Cycle

Access time from \overline{RAS}	t_{RAC}	–	50	–	60	–	70	ns	8, 9
Access time from \overline{CAS}	t_{CAC}	–	13	–	15	–	17	ns	8, 9
Access time from column address	t_{AA}	–	25	–	30	–	35	ns	8,10
OE access time	t_{OEA}	–	13	–	15	–	17	ns	
Column address to \overline{RAS} lead time	t_{RAL}	25	–	30	–	35	–	ns	
Read command setup time	t_{RCS}	0	–	0	–	0	–	ns	
Read command hold time	t_{RCH}	0	–	0	–	0	–	ns	11
Read command hold time referenced to \overline{RAS}	t_{RRH}	0	–	0	–	0	–	ns	11
\overline{CAS} to output in low-Z	t_{CLZ}	0	–	0	–	0	–	ns	8
Output buffer turn-off delay	t_{OFF}	0	13	0	15	0	17	ns	12

AC Characteristics (cont'd) ⁵⁾⁶⁾
 $T_A = 0 \text{ to } 70 \text{ }^\circ\text{C}$, $V_{CC} = 5 \text{ V} \pm 10 \%$, $t_T = 2 \text{ ns}$

Parameter	Symbol	Limit Values						Unit	Note
		-50		-60		-70			
		min.	max.	min.	max.	min.	max.		
Output turn-off delay from $\overline{\text{OE}}$	t_{OEZ}	0	13	0	15	0	17	ns	12
Data to $\overline{\text{CAS}}$ low delay	t_{DZC}	0	–	0	–	0	–	ns	13
Data to $\overline{\text{OE}}$ low delay	t_{DZO}	0	–	0	–	0	–	ns	13
$\overline{\text{CAS}}$ high to data delay	t_{CDD}	10	–	13	–	15	–	ns	14
$\overline{\text{OE}}$ high to data delay	t_{ODD}	10	–	13	–	15	–	ns	14

Write Cycle

Write command hold time	t_{WCH}	8	–	10	–	10	–	ns	
Write command pulse width	t_{WCP}	8	–	10	–	10	–	ns	
Write command setup time	t_{WCS}	0	–	0	–	0	–	ns	15
Write command to $\overline{\text{RAS}}$ lead time	t_{RWL}	13	–	15	–	17	–	ns	
Write command to $\overline{\text{CAS}}$ lead time	t_{CWL}	13	–	15	–	17	–	ns	
Data setup time	t_{DS}	0	–	0	–	0	–	ns	16
Data hold time	t_{DH}	8	–	10	–	12	–	ns	16

Read-modify-Write Cycle

Read-write cycle time	t_{RWC}	113	–	138	–	162	–	ns	
$\overline{\text{RAS}}$ to $\overline{\text{WE}}$ delay time	t_{RWD}	64	–	77	–	89	–	ns	15
$\overline{\text{CAS}}$ to $\overline{\text{WE}}$ delay time	t_{CWD}	27	–	32	–	36	–	ns	15
Column address to $\overline{\text{WE}}$ delay time	t_{AWD}	39	–	47	–	54	–	ns	15
$\overline{\text{OE}}$ command hold time	t_{OEH}	10	–	13	–	15	–	ns	

Hyper Page Mode (EDO) Cycle

Hyper page mode (EDO) cycle time	t_{HPC}	20	–	25	–	30	–	ns	
$\overline{\text{CAS}}$ precharge time	t_{CP}	8	–	10	–	10	–	ns	
Access time from $\overline{\text{CAS}}$ precharge	t_{CPA}	–	27	–	32	–	37	ns	7
Output data hold time	t_{COH}	5	–	5	–	5	–	ns	
$\overline{\text{RAS}}$ pulse width in EDO mode	t_{RAS}	50	200k	60	200k	70	200k	ns	
$\overline{\text{CAS}}$ precharge to $\overline{\text{RAS}}$ Delay	t_{RHPC}	27	–	32	–	37	–	ns	

AC Characteristics (cont'd) 5)6)

$T_A = 0$ to 70 °C, $V_{CC} = 5$ V \pm 10 %, $t_T = 2$ ns

16E

Parameter	Symbol	Limit Values						Unit	Note
		-50		-60		-70			
		min.	max.	min.	max.	min.	max.		

Hyper Page Mode (EDO) Read-modify-Write Cycle

Hyper page mode (EDO) read-write cycle time	t_{PRWC}	58	–	68	–	77	–	ns	
\overline{CAS} precharge to \overline{WE}	t_{CPWD}	41	–	49	–	56	–	ns	

\overline{CAS} -before- \overline{RAS} Refresh Cycle

\overline{CAS} setup time	t_{CSR}	10	–	10	–	10	–	ns	
\overline{CAS} hold time	t_{CHR}	10	–	10	–	10	–	ns	
\overline{RAS} to \overline{CAS} precharge time	t_{RPC}	5	–	5	–	5	–	ns	
Write to \overline{RAS} precharge time	t_{WRP}	10	–	10	–	10	–	ns	
Write hold time referenced to \overline{RAS}	t_{WRH}	10	–	10	–	10	–	ns	

\overline{CAS} -before- \overline{RAS} Counter Test Cycle

\overline{CAS} precharge time	t_{CPT}	35	–	40	–	40	–	ns	
---------------------------------	-----------	----	---	----	---	----	---	----	--

Self Refresh Cycle

\overline{RAS} pulse width	t_{RASS}	100k	–	100k	–	100k	–	ns	17
\overline{RAS} precharge	t_{RPS}	95	–	110	–	130	–	ns	17
\overline{CAS} hold time	t_{CHS}	– 50	–	– 50	–	– 50	–	ns	17

Test Mode

Write command setup time	t_{WTS}	10	–	10	–	10	–	ns	
Write command hold time	t_{WTH}	10	–	10	–	10	–	ns	
\overline{CAS} hold time	t_{CHRT}	30	–	30	–	30	–	ns	

Notes:

- 1) All voltages are referenced to V_{SS} .
- 2) I_{CC1} , I_{CC3} , I_{CC4} and I_{CC6} depend on cycle rate.
- 3) I_{CC1} and I_{CC4} depend on output loading. Specified values are obtained with the output open.
- 4) Address can be changed once or less while $RAS = V_{IL}$. In case of I_{CC4} it can be changed once or less during a hyper page mode (EDO) cycle.
- 5) An initial pause of 200 μs is required after power-up followed by 8 \overline{RAS} cycles of which at least one cycle has to be a refresh cycle, before proper device operation is achieved. In case of using the internal refresh counter, a minimum of 8 CAS-before-RAS initialization cycles instead of 8 RAS cycles are required.
- 6) AC measurements assume $t_T = 2$ ns.
- 7) $V_{IH (min.)}$ and $V_{IL (max.)}$ are reference levels for measuring timing of input signals. Transition times are also measured between V_{IH} and V_{IL} .
- 8) Measured with the specified current load and 100 pF at $V_{OL} = 0.8$ V and $V_{OH} = 2.0$ V. Access time is determined by the latter of t_{RAC} , t_{CAC} , t_{AA} , t_{CPA} , t_{OEA} , t_{CAC} is measured from tristate.
- 9) Operation within the $t_{RCD (max.)}$ limit ensures that $t_{RAC (max.)}$ can be met. $t_{RCD (max.)}$ is specified as a reference point only. If t_{RCD} is greater than the specified $t_{RCD (max.)}$ limit, then access time is controlled by t_{CAC} .
- 10) Operation within the $t_{RAD (max.)}$ limit ensures that $t_{RAC (max.)}$ can be met. $t_{RAD (max.)}$ is specified as a reference point only. If t_{RAD} is greater than the specified $t_{RAD (max.)}$ limit, then access time is controlled by t_{AA} .
- 11) Either t_{RCH} or t_{RPH} must be satisfied for a read cycle.
- 12) $t_{OFF (max.)}$, $t_{OEZ (max.)}$ define the time at which the output achieves the open-circuit conditions and are not referenced to output voltage levels. t_{OFF} is referenced from the rising edge of \overline{RAS} or \overline{CAS} , whichever occurs last.
- 13) Either t_{DZC} or t_{DZO} must be satisfied.
- 14) Either t_{CDD} or t_{ODD} must be satisfied.
- 15) t_{WCS} , t_{RWD} , t_{CWD} and t_{AWD} are not restrictive operating parameters. They are included in the data sheet as electrical characteristics only. If $t_{WCS} > t_{WCS (min.)}$, the cycle is an early write cycle and data out pin will remain open-circuit (high impedance) through the entire cycle; if $t_{RWD} > t_{RWD (min.)}$, $t_{CWD} > t_{CWD (min.)}$ and $t_{AWD} > t_{AWD (min.)}$, the cycle is a read-write cycle and I/O will contain data read from the selected cells. If neither of the above sets of conditions is satisfied, the condition of I/O (at access time) is indeterminate.
- 16) These parameters are referenced to the \overline{CAS} leading edge in early write cycles and to the \overline{WE} leading edge in read-write cycles.
- 17) When using Self Refresh mode, the following refresh operations must be performed to ensure proper DRAM operation:

If row addresses are being refreshed on an evenly distributed manner over the refresh interval using CBR refresh cycles, then only one CBR cycle must be performed immediately after exit from Self Refresh.

If row addresses are being refreshed in any other manner (ROR - Distributed/Burst; or CBR-Burst) over the refresh interval, then a full set of row refreshes must be performed immediately before entry to and immediately after exit from Self Refresh.

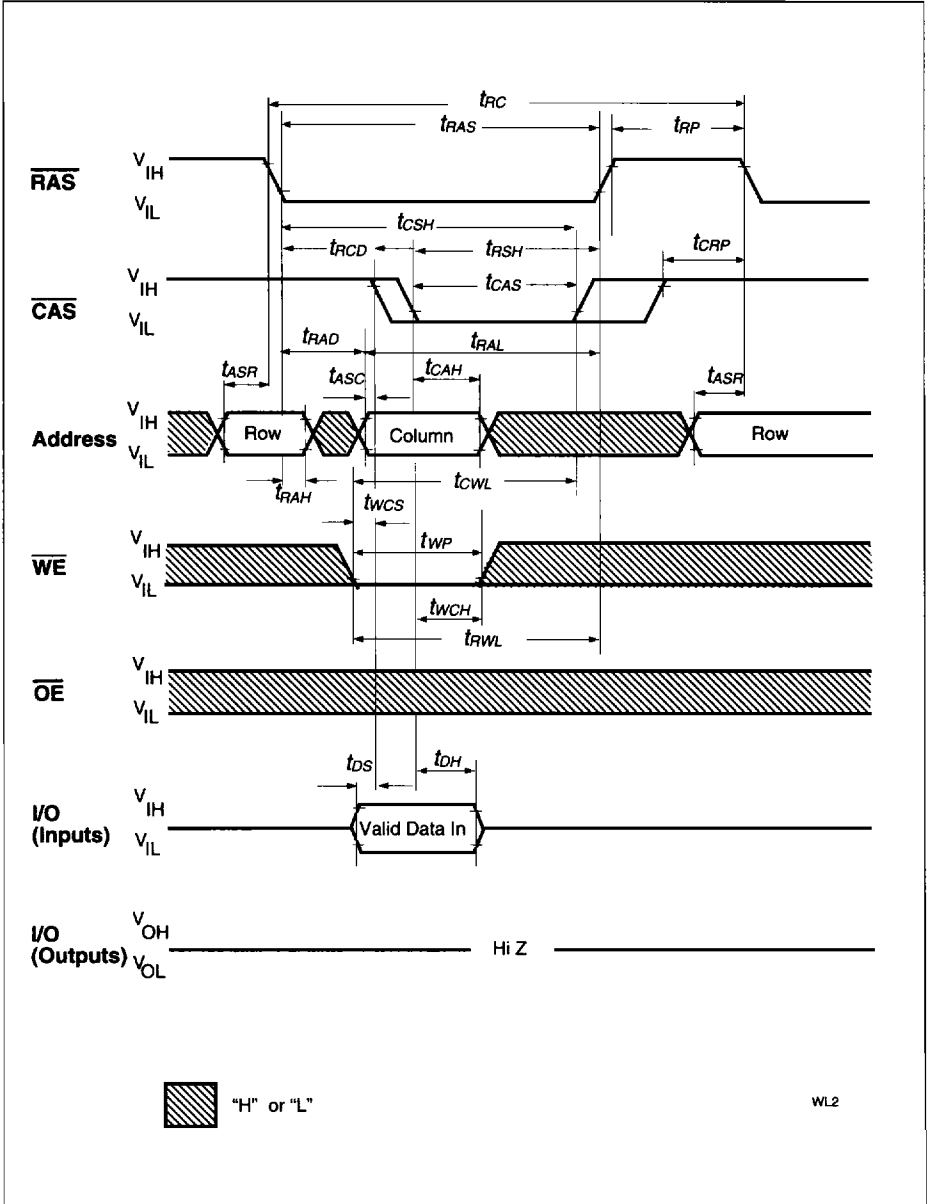

Write Cycle (Early Write)

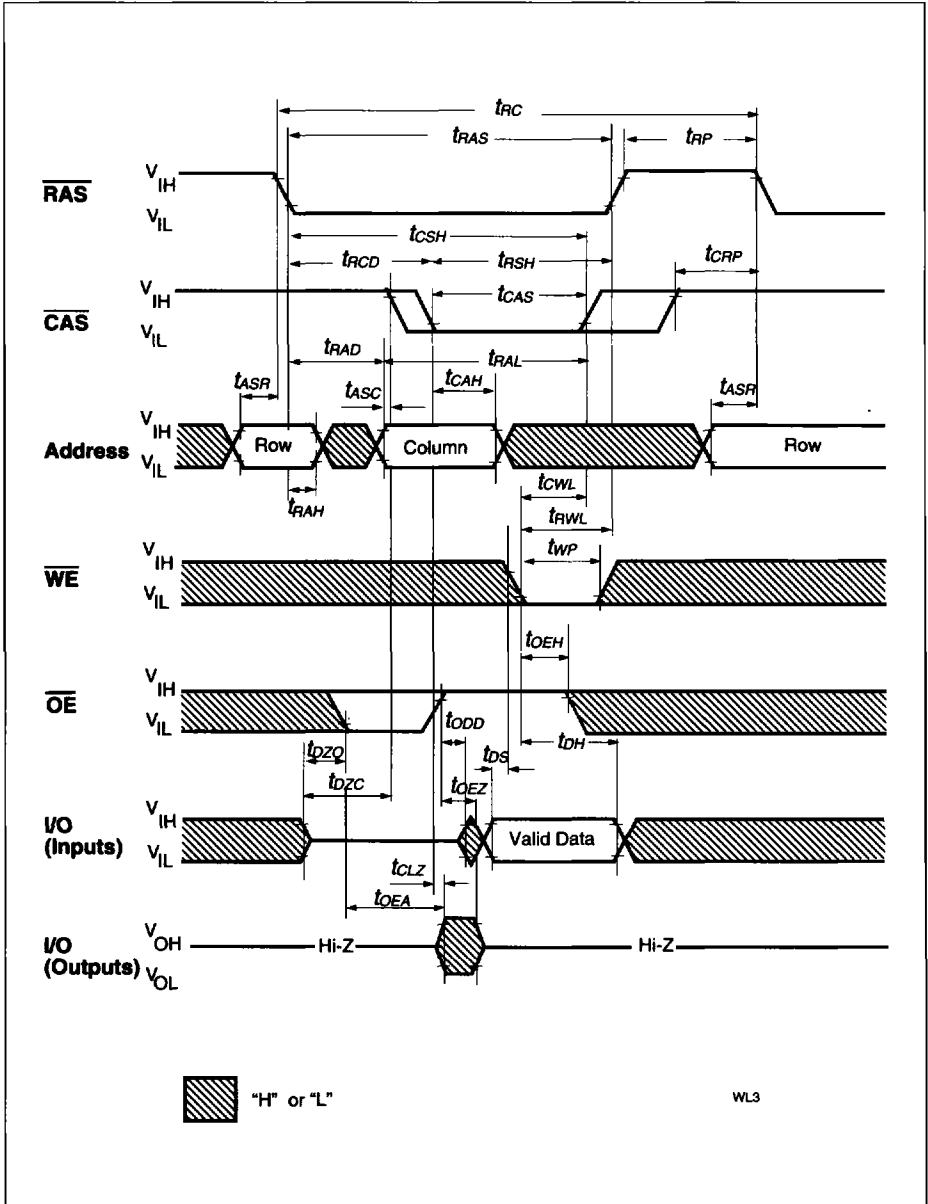

Write Cycle (\overline{OE} Controlled Write)

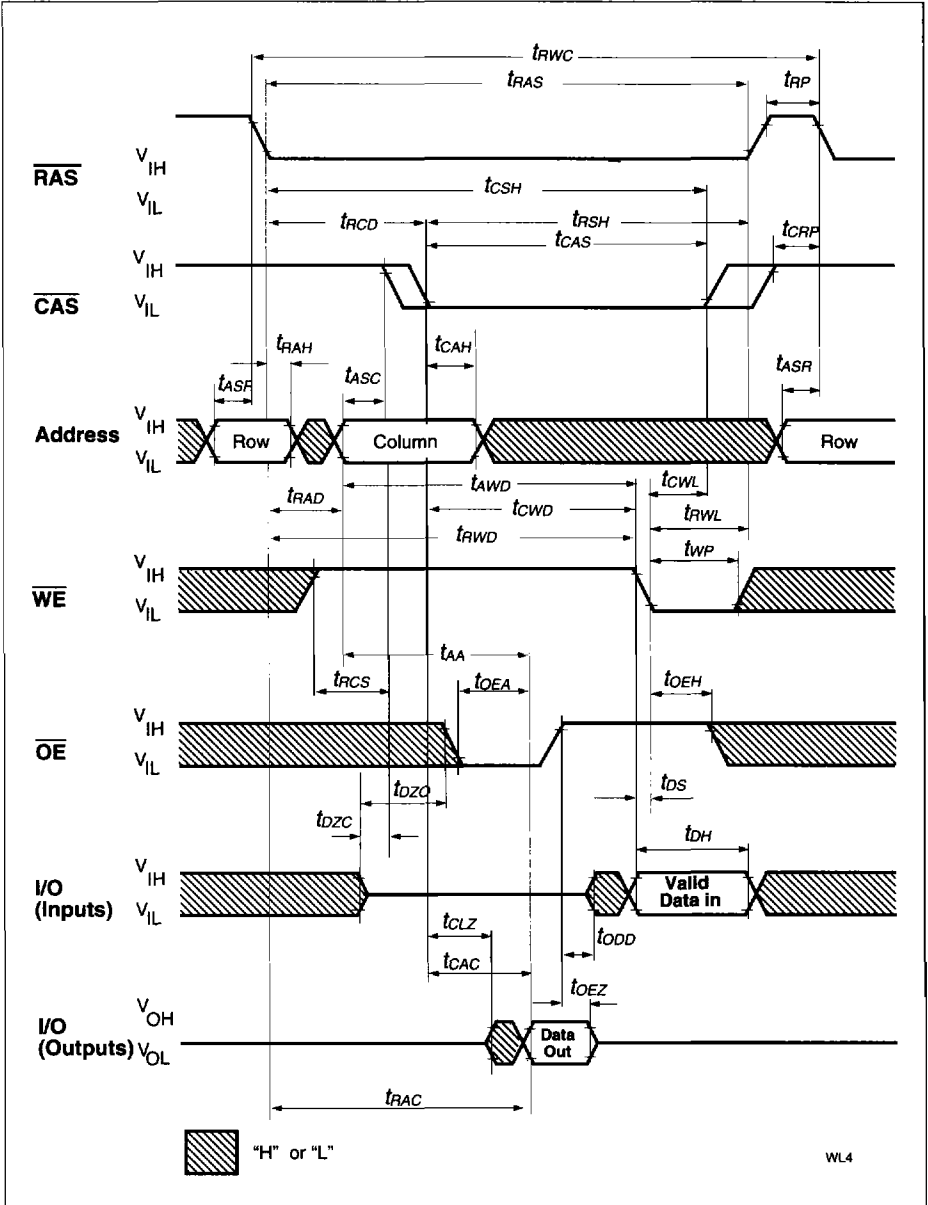

Read-Write (Read-Modify-Write) Cycle

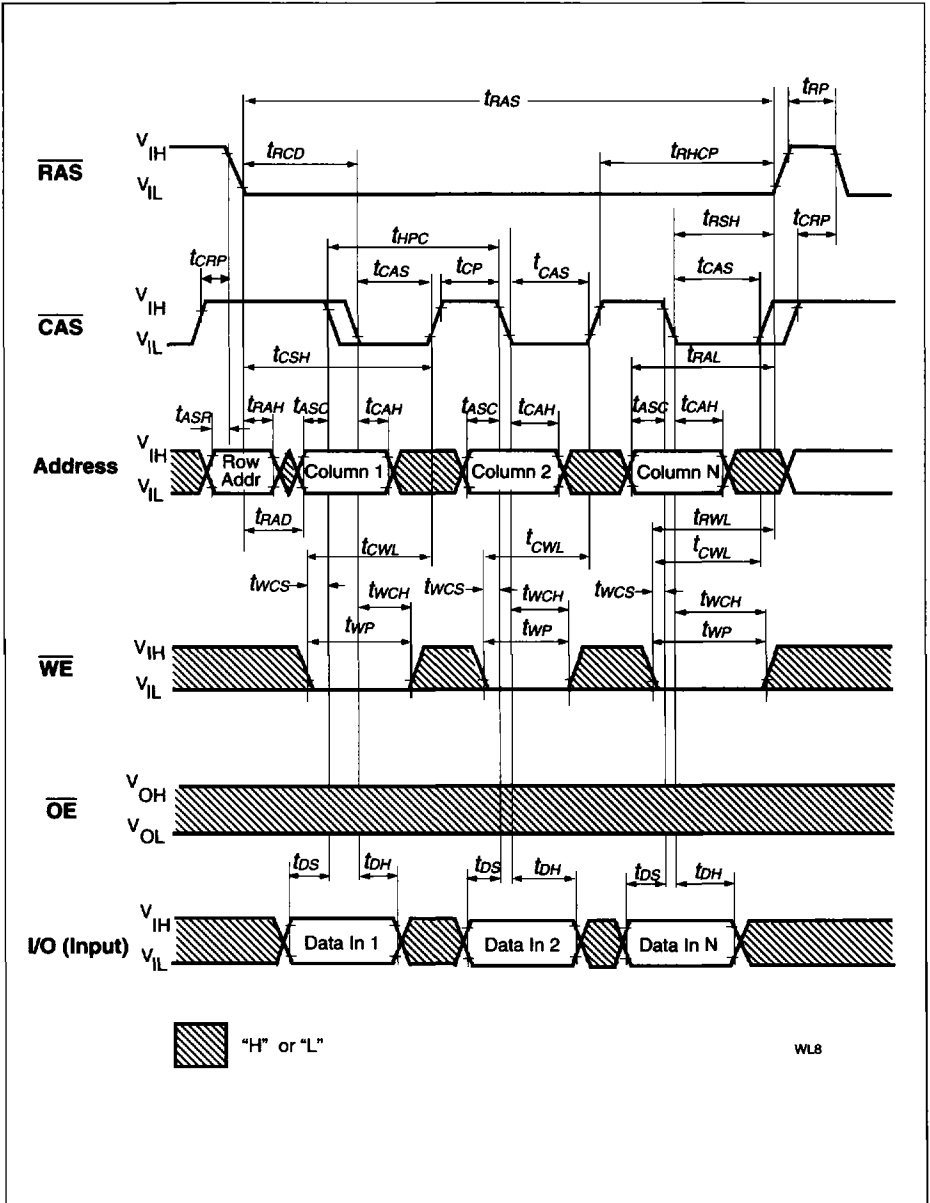

Hyper Page Mode (EDO) Early Write Cycle

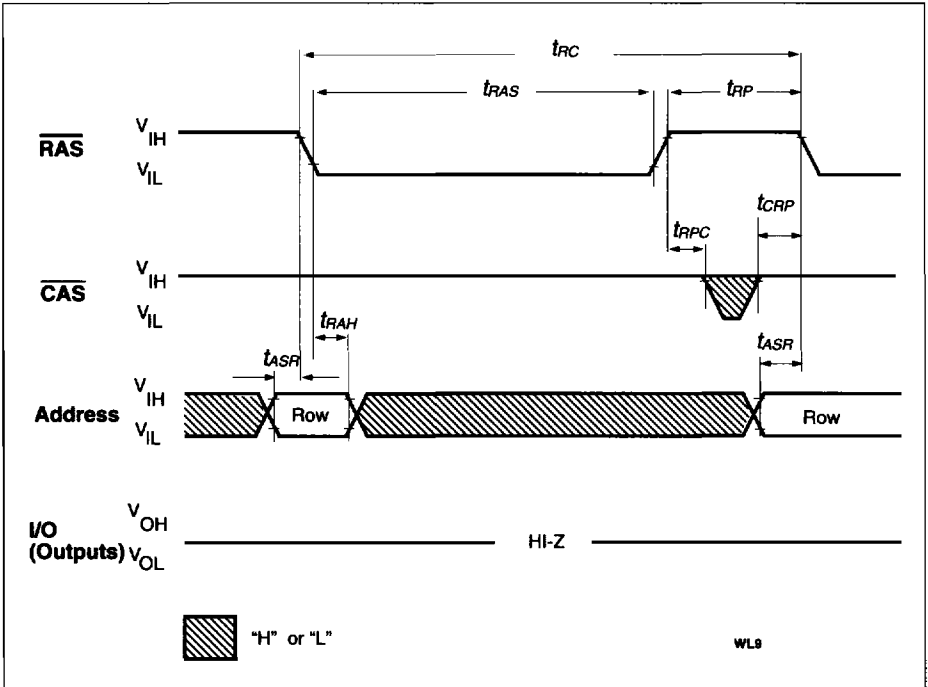

$\overline{\text{RAS}}$ -Only Refresh Cycle

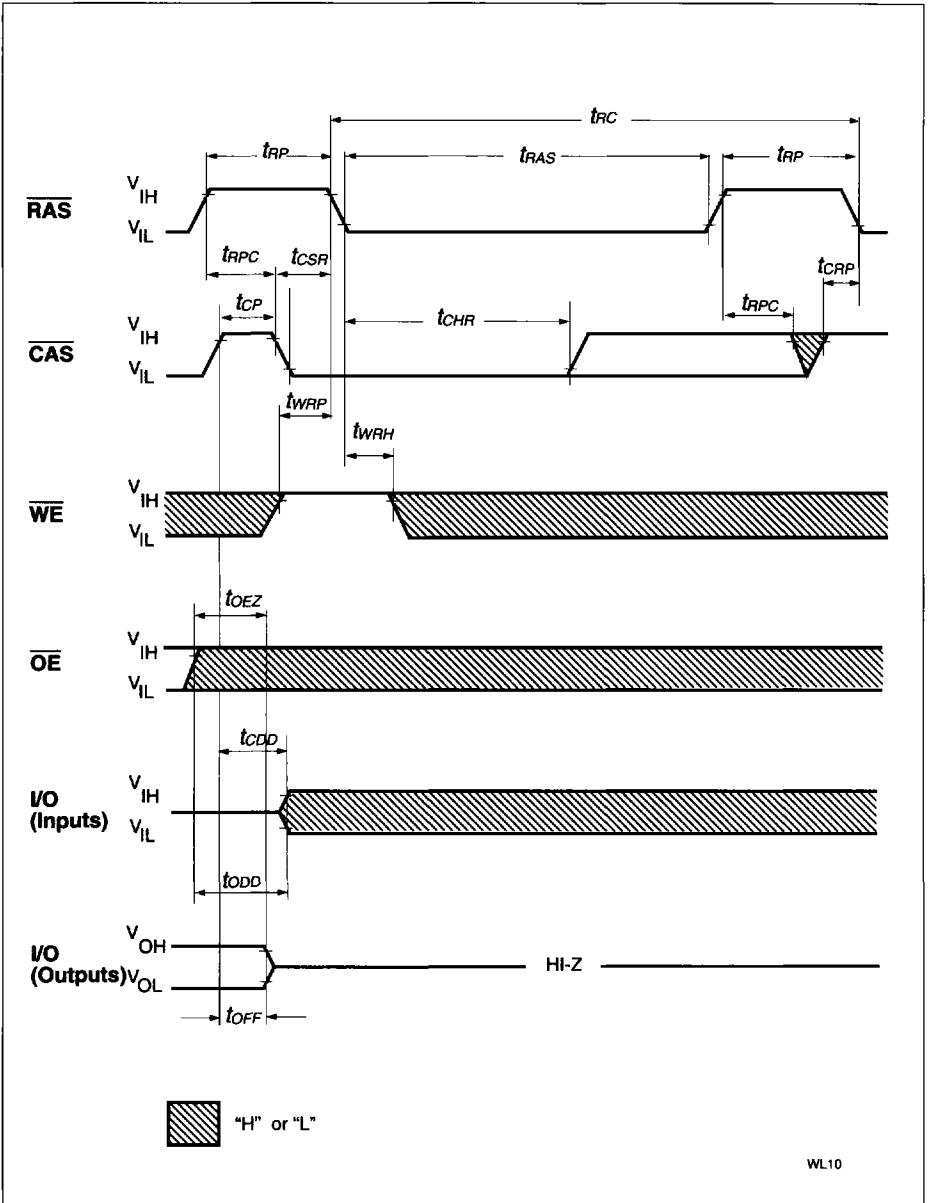

CAS-Before-RAS Refresh Cycle

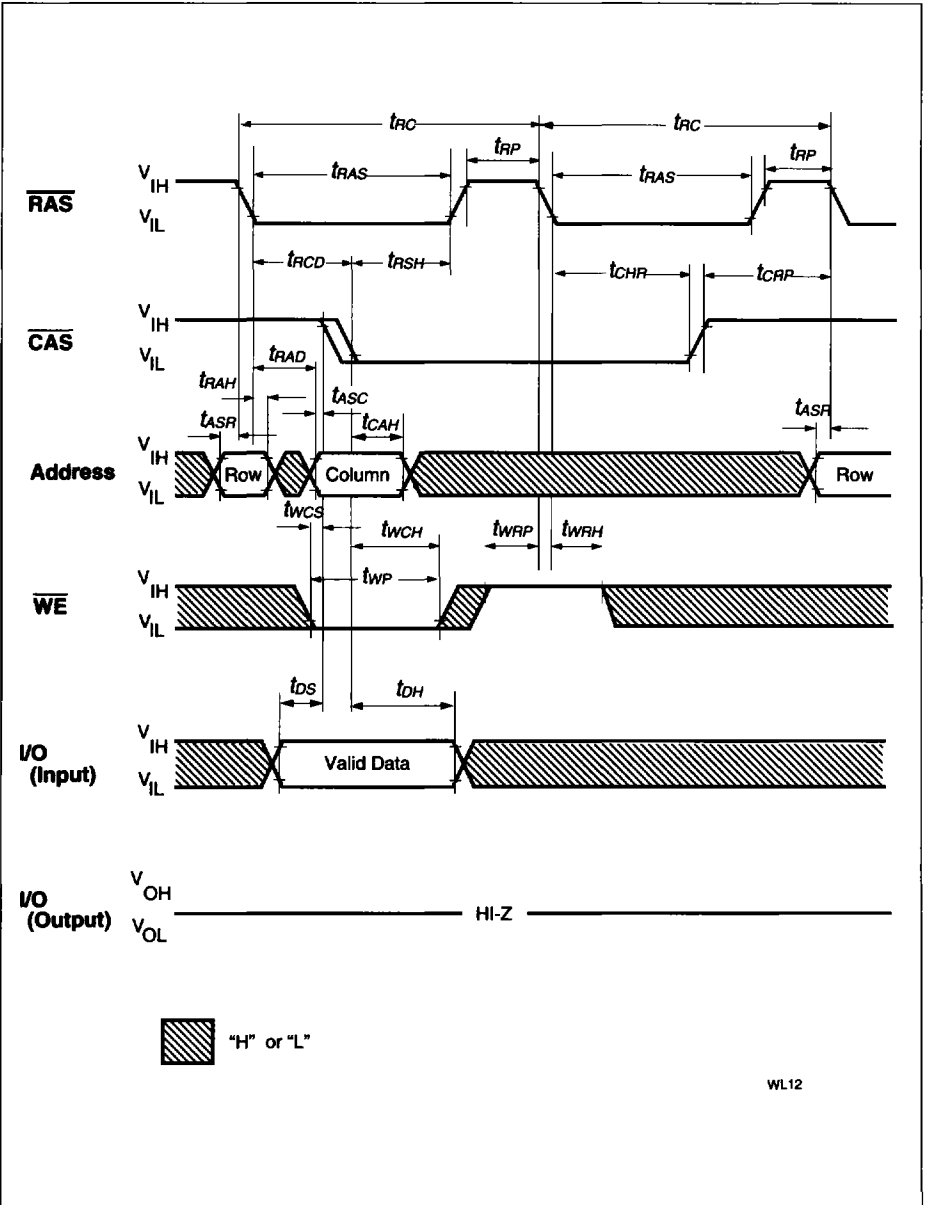

Hidden Refresh Cycle (Early Write)

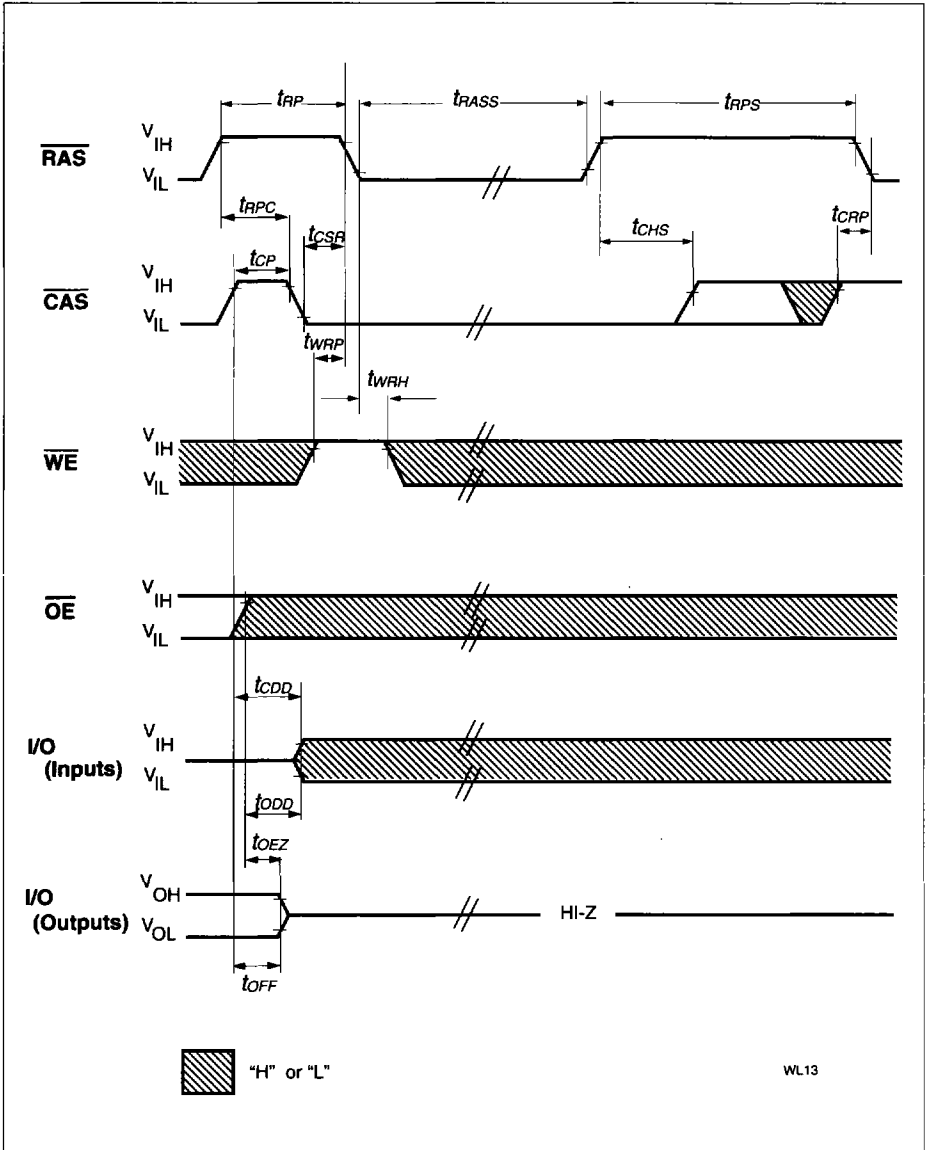

CAS before RAS Self Refresh Cycle

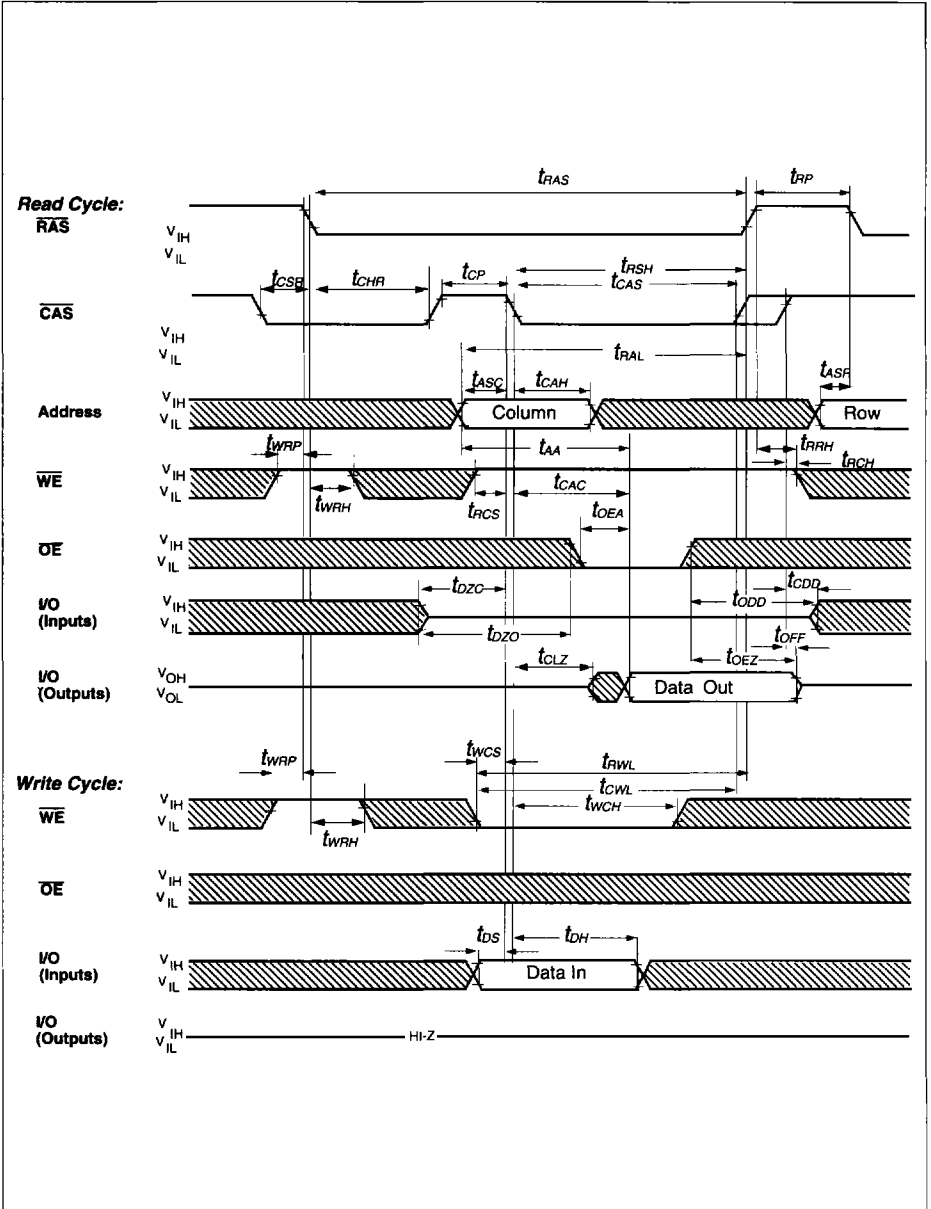

CAS-Before-RAS Refresh Counter Test Cycle

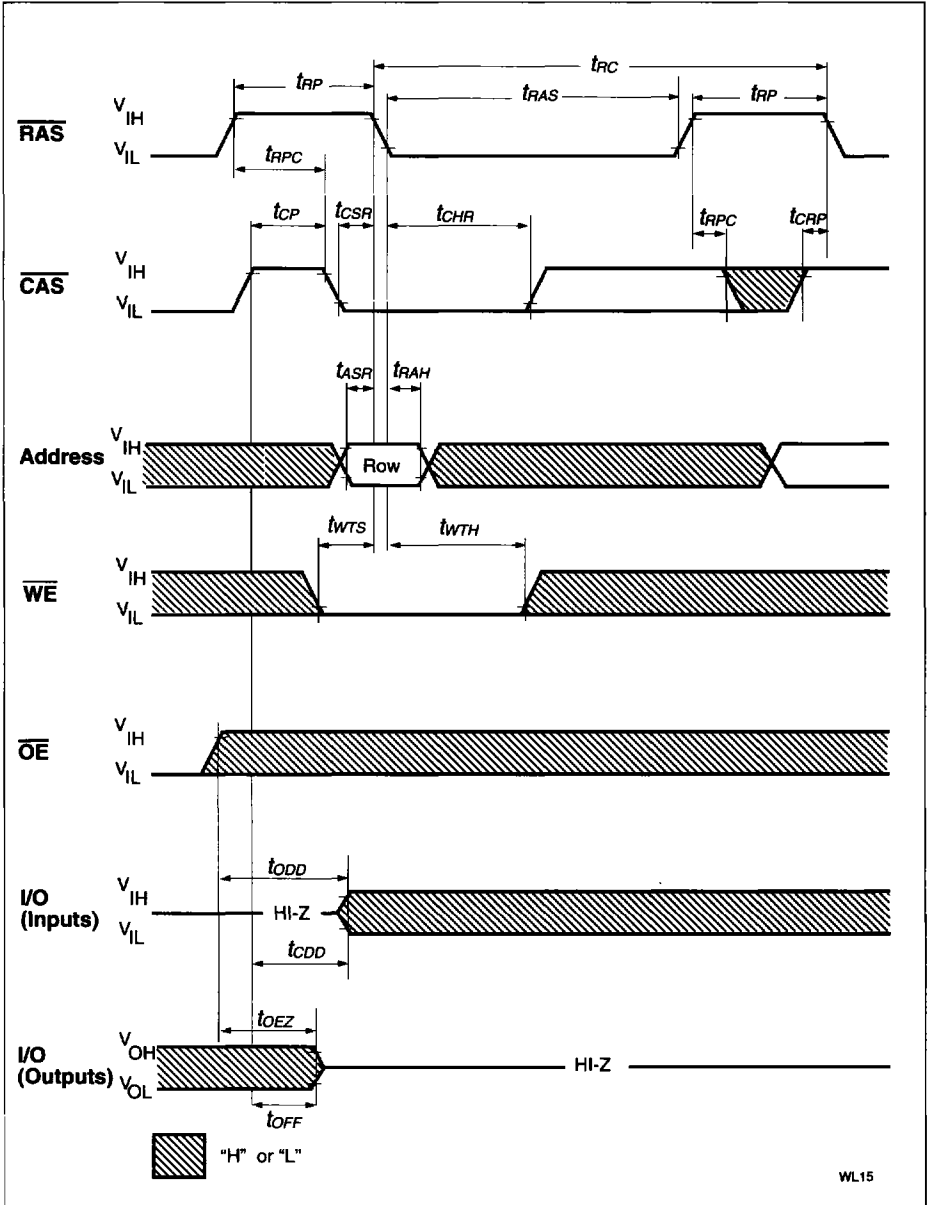

Test Mode Entry

Test Mode

As the HYB 5116(7)405BJ/BT is organized internally as 1 M x 16-bits, a test mode cycle using 4:1 compression can be used to improve test time. Note that in the 4 M x 4 version the test time is reduced by 1/4 for a N test pattern.

In a test mode "write" the data from each I/O pin is written into four 1M blocks simultaneously (all "1" s or all "0" s). In test mode "read" each I/O output is used for indicating the test mode result. If the internal four bits are equal, the I/O would indicate a "1". If they were not equal, the I/O would indicate a "0". The WCBR cycle (\overline{WE} , \overline{CAS} before \overline{RAS}) puts the device into test mode. To exit from test mode, a " \overline{CAS} before \overline{RAS} refresh", " \overline{RAS} only refresh" or "Hidden refresh" can be used. Refresh during test mode operation can be performed by normal read cycles or by WCBR refresh cycles.

Row addresses A0 through A9 have to be kept high to perform a testmode entry cycle. All other addresses are don't care.

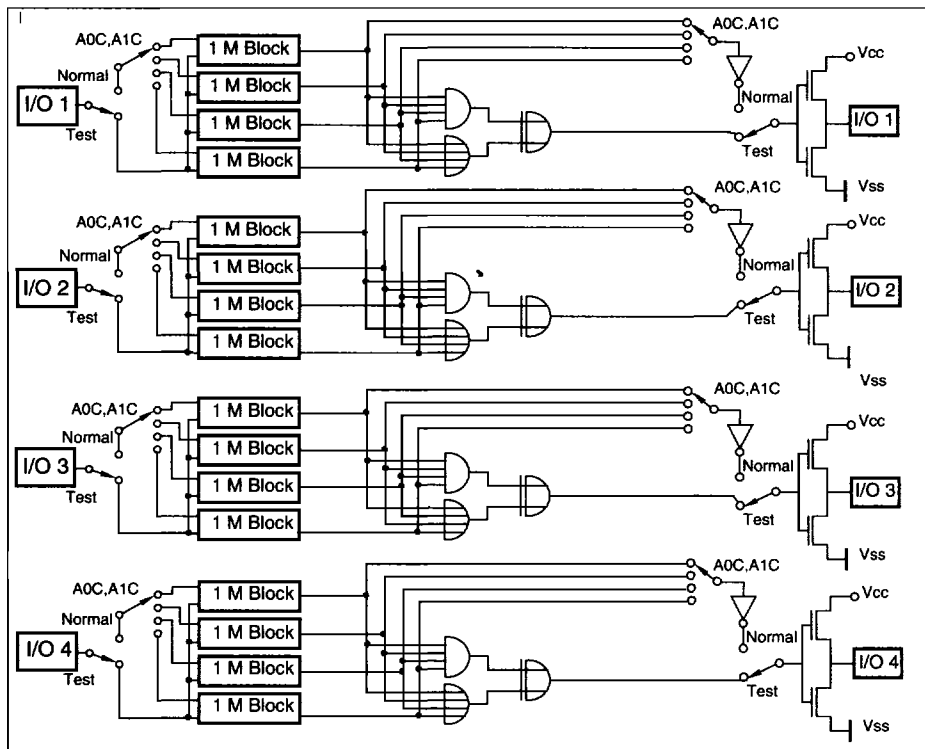

Block Diagram in Test Mode

Package Outlines

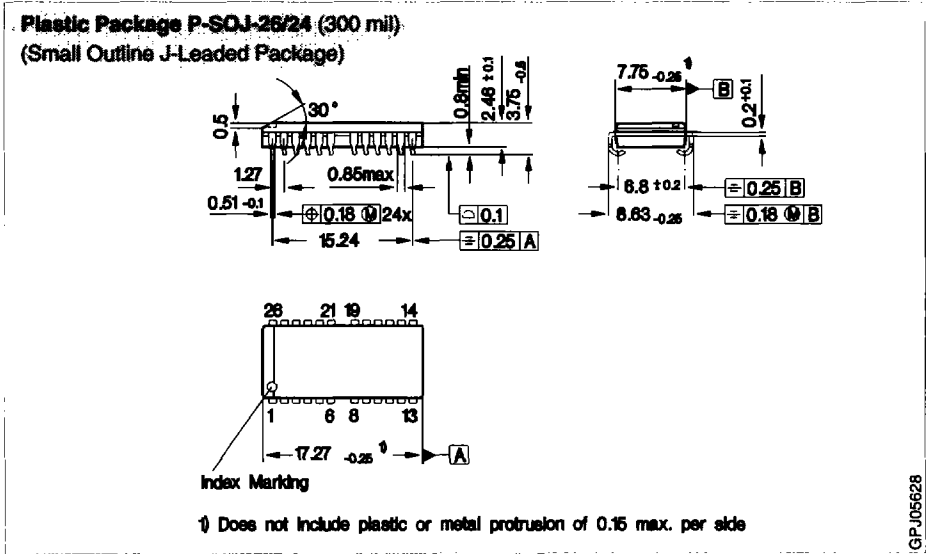

Sorts of Packing

Package outlines for tubes, trays etc. are contained in our Data Book "Package Information".

SMD = Surface Mounted Device

Dimensions in mm