

## Features

- Fully Integrated Low IF Receiver
- Fully Integrated GFSK Modulator for 72, 144, 288, 576 and 1152 Kbits/s
- High Sensitivity of Typically  $-93$  dBm Due to Integrated LNA
- High Output Power of Typically  $+4$  dBm
- Multi-channel Operation
  - 95 Channels
  - Support Frequency Hopping (ETSI) and Digital Modulation (FCC)
- Supply-voltage Range 2.9V to 3.6V (Unregulated)
- Auxiliary Voltage Regulator on Chip (3.2V to 4.6V)
- Low Current Consumption
- Few Low-cost External Components
- Integrated Ramp-signal Generator and Power Control for an Additional Power Amplifier
- Low Profile Lead-free Plastic Package QFN32 (5 mm  $\times$  5 mm  $\times$  0.9 mm)
- RoHs Compliant

## Applications

- High-tech Multi-user Toys
- Wireless Game Controllers
- Telemetry
- Wireless Audio/Video
- Electronic Point of Sales
- Wireless Head Set
- FCC CFR47, Part 15, ETSI EN 300 328, EN 300 440 and ARIB STD-T-66 Compliant Radio Links

## 1. Description

The ATR2406 is a single chip RF transceiver intended for applications in the 2.4-GHz ISM band. The QFN32-packaged IC is a complete transceiver including image rejection mixer, low IF filter, FM demodulator, RSSI, TX preamplifier, power-ramping generator for external power amplifier, integrated synthesizer, and a fully integrated VCO and TX filter. No mechanical adjustment is necessary in production.

The RF transceiver offers a clock recovery function on-chip.

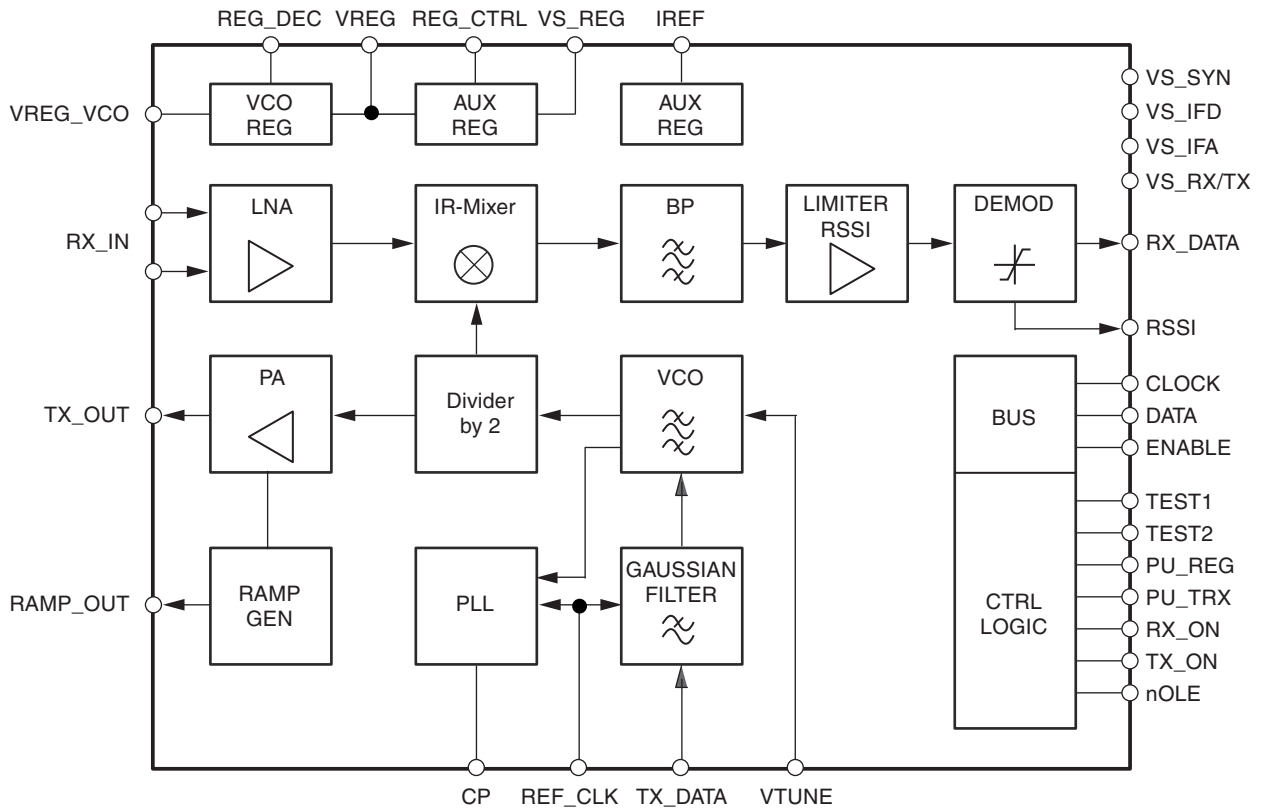


## Low-IF 2.4-GHz ISM Transceiver

## ATR2406

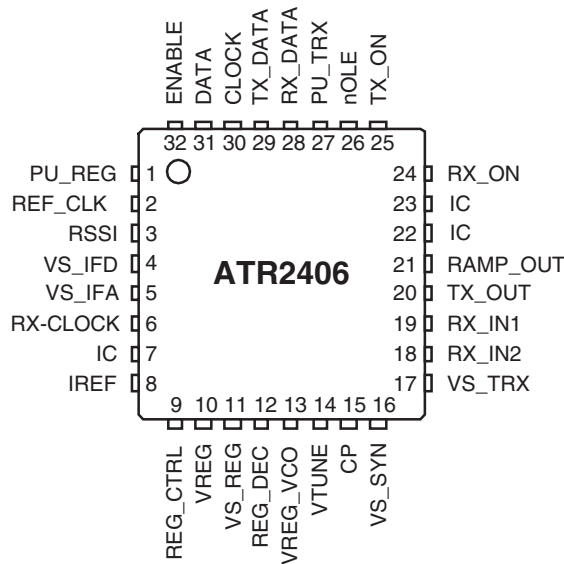


**Figure 1-1. Block Diagram**



## 2. Pin Configuration

**Figure 2-1. Pinning QFN32 - 5 × 5**



**Table 2-1.** Pin Description

| Pin    | Symbol   | Function   |
|--------|----------|--|
| 1      | PU_REG   | Power-up input for auxiliary regulator                                       |
| 2      | REF_CLK  | Reference frequency input  |
| 3      | RSSI     | Received signal strength indicator output                                    |
| 4      | VS_IFD   | Digital supply voltage   |
| 5      | VS_IFA   | Analog supply voltage for IF circuits  |
| 6      | RX-CLOCK | RX-CLOCK, if RX mode with clock recovery is active                           |
| 7      | IC       | Internally connected. Connect to $V_S$ if internal AUX regulator is not used |
| 8      | IREF     | External resistor for band-gap reference                                     |
| 9      | REG_CTRL | Auxiliary voltage regulator control output                                   |
| 10     | VREG     | Auxiliary voltage regulator output   |
| 11     | VS_REG   | Auxiliary voltage regulator supply voltage                                   |
| 12     | REG_DEC  | Decoupling pin for VCO_REG   |
| 13     | VREG_VCO | VCO voltage regulator  |
| 14     | VTUNE    | VCO tuning voltage input   |
| 15     | CP       | Charge-pump output   |
| 16     | VS_SYN   | Synchronous supply voltage   |
| 17     | VS_TRX   | Transmitter receiver supply voltage  |
| 18     | RX_IN2   | Differential receiver input 2  |
| 19     | RX_IN1   | Differential receiver input 1  |
| 20     | TX_OUT   | TX driver amplifier output   |
| 21     | RAMP_OUT | Ramp generator output for PA power ramping                                   |
| 22     | IC       | Internally connected, do not connect on PCB                                  |
| 23     | IC       | Internally connected, do not connect on PCB                                  |
| 24     | RX_ON    | RX control input   |
| 25     | TX_ON    | TX control input   |
| 26     | nOLE     | Open loop enable input   |
| 27     | PU_TRX   | RX/TX/PLL/VCO power-up input   |
| 28     | RX_DATA  | RX data output   |
| 29     | TX_DATA  | TX data input  |
| 30     | CLOCK    | 3-wire-bus: Clock input  |
| 31     | DATA     | 3-wire-bus: Data input   |
| 32     | ENABLE   | 3-wire-bus: Enable input   |
| Paddle | GND      | Ground   |

## 3. Functional Description

### 3.1 Receiver

The RF signal at RF\_IN is differentially fed through the LNA to the image rejection mixer IR\_MIXER, driving the integrated low-IF band-pass filter. The IF frequency is 864 kHz. The limiting IF\_AMP with an integrated RSSI function feeds the signal to the digital demodulator DEMOD. No tuning is required. Data slicing is handled internally.

### 3.2 Clock Recovery

For a 1152-kBit/s data rate, the receiver has a clock recovery function on-chip.

The receiver includes a clock recovery circuit which regenerates the clock out of the received data. The advantage is that this recovered clock is synchronous to the clock of the transmitting device (and thus to the transmitted data), which significantly reduces the load of the processing microcontroller.

The falling edge of the clock is the optimal sampling position for the RX\_Data signal, so at this event the data must be sampled by the microcontroller. The recovered clock is available at pin 6.

### 3.3 Transmitter

The transmit data at TX\_DATA is filtered by an integrated Gaussian filter (GF) and fed to the fully integrated VCO operating at twice the output frequency. After modulation, the signal is frequency divided by 2 and fed to the internal preamplifier PA. This preamplifier supplies typically +4 dBm output power at TX\_OUT.

A ramp-signal generator RAMP\_GEN, providing a ramp signal at RAMP\_OUT for the external power amplifier, is integrated. The slope of the ramp signal is controlled internally so that spurious requirements are fulfilled.

### 3.4 Synthesizer

The IR\_MIXER, the PA, and the programmable counter (PC) are driven by the fully integrated VCO, using on-chip inductors and varactors. The output signal is frequency divided to supply the desired frequency to the TX\_DRIVER, the 0/90 degree phase shifter for the IR\_MIXER, and to be used by the PC for the phase detector (PD) ( $f_{PD} = 1.728 \text{ MHz}$ ). Open loop modulation is supported.

### 3.5 Power Supply

An integrated band-gap-stabilized voltage regulator for use with an external low-cost PNP transistor is implemented. Multiple power-down and current saving modes are provided.

## 4. Absolute Maximum Ratings

Stresses beyond those listed under “Absolute Maximum Ratings” may cause permanent damage to the device. This is a stress rating only and functional operation of the device at these or any other conditions beyond those indicated in the operational sections of this specification is not implied. Exposure to absolute maximum rating conditions for extended periods may affect device reliability.

| Parameters                         | Symbol         | Min. | Max.  | Unit |
|------------------------------------|----------------|------|-------|------|
| Supply voltage auxiliary regulator | $V_S$          | -0.3 | +4.7  | V    |
| Supply voltage                     | $V_S$          | -0.3 | +3.6  | V    |
| Control voltages                   | $V_{contr}$    | -0.3 | $V_S$ | V    |
| Storage temperature                | $T_{stg}$      | -40  | +125  | °C   |
| Input RF level                     | $P_{RF}$       |      | +10   | dBm  |
| ESD protection                     | $V_{ESD\_ana}$ |      | TBD   | V    |
|                                    | $V_{ESD\_dig}$ |      | TBD   | V    |

Electrostatic sensitive device.  
Observe precautions for handling.



## 5. Operating Range

| Parameters                         | Symbol        | Min. | Max. | Unit |
|------------------------------------|---------------|------|------|------|
| Supply voltage                     | $V_S$         | 2.9  | 3.6  | V    |
| Auxiliary regulator supply voltage | $V_{S\_BATT}$ | 3.2  | 4.6  | V    |
| Temperature ambient                | $T_{amb}$     | -10  | +60  | °C   |
| Input frequency range              | $f_{RX}$      | 2400 | 2483 | MHz  |

## 6. Electrical Characteristics

$V_S = 3.6V$  with AUX regulator,  $T_{amb} = 25^\circ C$ , unless otherwise specified

| No.      | Parameters   | Test Conditions  | Symbol               | Min.                | Typ.      | Max.     | Unit    |
|----------|--|--|----------------------|---------------------|-----------|----------|---------|
| <b>1</b> | <b>Supply</b>  |  |                      |                     |           |          |         |
| 1.1      | Supply voltage   | With AUX regulator   | $V_S$                | 3.2                 | 3.6       | 4.6      | V       |
| 1.2      | Supply voltage   | Without AUX regulator  | $V_S$                | 2.9                 | 3.0       | 3.6      | V       |
| 1.3      | RX supply current  | CW mode (peak current)   | $I_S$                |                     | 57        |          | mA      |
|          |  | Burst mode at 10 Kbits/s <sup>(4)</sup>  | $I_S$                |                     | 625       |          | $\mu A$ |
| 1.4      | TX supply current  | CW mode (peak current)   | $I_S$                |                     | 42        |          | mA      |
|          |  | Burst mode at 10 Kbits/s <sup>(4)</sup>  | $I_S$                |                     | 500       |          | $\mu A$ |
| 1.5      | Battery lifetime of a remote control application using an AVR <sup>®</sup> | See <a href="#">Section 10. "Appendix: Current Calculations for a Remote Control" on page 20</a>                               |                      |                     |           |          |         |
| 1.6      | Supply current in power-down mode  | With AUX regulator<br>PU_TRX = 0; PU_REG = 0   | $I_S$                |                     | < 1       |          | $\mu A$ |
| 1.7      | Supply current in power-down mode  | Without AUX regulator<br>PU_TRX = 0; PU_REG = 0  | $I_S$                |                     | < 1       |          | $\mu A$ |
| <b>2</b> | <b>Voltage Regulator</b>   |  |                      |                     |           |          |         |
| 2.1      | AUX regulator  |  | VREG                 |                     | 3.0       |          | V       |
| 2.2      | VCO regulator  |  | VREG_VCO             |                     | 2.7       |          | V       |
| <b>3</b> | <b>Transmitter Part</b>  |  |                      |                     |           |          |         |
| 3.1      | TX data rate   |  |                      | 72/144/288/576/1152 |           |          | kBits/s |
| 3.2      | Output power   |  | PTX                  |                     | 4         |          | dBm     |
| 3.3      | TX data filter clock   | 9 taps in filter   | $f_{TXFCLK}$         | 10.368/13.824       |           |          | MHz     |
| 3.4      | Frequency deviation  | To be tuned by GFCS bits   | $GF_{FM\_nom}$       |                     | $\pm 400$ |          | kHz     |
| 3.5      | Frequency deviation scaling <sup>(3)</sup>                                 | GFFM = $GF_{FM\_nom} \times GFCS$<br>(Refer to bus protocol D9 to D11)   | GFCS                 | 60                  |           | 130      | %       |
| 3.6      | Frequency drift  | With standard loop filter and slot length of 1400 $\mu s$ (Refer to the application note "ATR2406 Loop Filter and Data Rates") | $\Delta f_o$ (drift) |                     |           | $\pm 40$ | kHz     |
| 3.7      | Harmonics  | BW = 100 kHz <sup>(1)</sup>  |                      |                     |           | -41.2    | dBm     |
| 3.8      | Spurious emissions   | BW = 100 kHz <sup>(1)</sup>  |                      |                     |           | -57      | dBm     |
|          | 30 – 1000 MHz  |  |                      |                     |           | -57      | dBm     |
|          | 1 – 12.75 GHz  |  |                      |                     |           | -57      | dBm     |
|          | 1.8 – 1.9 GHz  |  |                      |                     |           | -57      | dBm     |
|          | 5.15 – 5.3 GHz   |  |                      |                     |           | -57      | dBm     |
| <b>4</b> | <b>Ramp Generator, Pin 21</b>  |  |                      |                     |           |          |         |
| 4.1      | Minimum output voltage   | TX_ON = low  | $V_{min}$            |                     | 0.7       |          | V       |
| 4.2      | Maximum output voltage   | Refer to bus protocol D12 to D13   | $V_{max}$            | 1.1                 |           | 1.9      | V       |
| 4.3      | Rise time  |  | $t_r$                |                     | 5         |          | $\mu s$ |
| 4.4      | Fall time  |  | $t_f$                |                     | 5         |          | $\mu s$ |

- Notes:
1. Measured and guaranteed only on the Atmel<sup>®</sup> evaluation board, including microstrip filter, balun, and Smart Radio Frequency (Smart RF) firmware. Conducted measured.
  2. Timing is determined by external loop filter characteristics. Faster timing can be achieved by modification of the loop filter. For further information refer to the application notes.
  3. The Gaussian filter control setting (GFCS) is used to compensate production tolerances by tuning the modulation deviation in production to the nominal value of 400 kHz.
  4. Burst mode with 0.9% duty cycle

## 6. Electrical Characteristics (Continued)

$V_S = 3.6V$  with AUX regulator,  $T_{amb} = 25^\circ C$ , unless otherwise specified

| No.      | Parameters   | Test Conditions  | Symbol            | Min. | Typ.       | Max.           | Unit     |
|----------|--|--|-------------------|------|------------|----------------|----------|
| <b>5</b> | <b>Receiver Part</b>   |  |                   |      |            |                |          |
| 5.1      | RX input impedance   | Differential   | $Z_{in}$          |      | 170 + j0   |                | $\Omega$ |
| 5.2      | Sensitivity  | At input for $BER \leq 10^{-3}$<br>at 1152 kBits/s <sup>(1)</sup>  |                   |      | -93        |                | dBm      |
| 5.3      | Third order input intercept point                                      |  | IIP3              |      | -15        |                | dBm      |
| 5.4      | Intermodulation rejection  | $BER < 10^{-3}$ , wanted at -83 dBm,<br>level of interferers in channels<br>$N + 2$ and $N + 4$ <sup>(1)</sup>       | $IM_3$            | 32   |            |                | dBc      |
| 5.5      | Co-channel rejection   | $BER < 10^{-3}$ , wanted at -76 dBm <sup>(1)</sup>   | $R_{CO}$          | -11  |            |                | dBc      |
| 5.6      | Adjacent channel rejection<br>$\pm 1.728$ MHz                          | $BER < 10^{-3}$ , wanted at -76 dBm,<br>adjacent level referred to wanted<br>channel level <sup>(1)</sup>            | $R_{i(N-1)}$      | 14   |            |                | dBc      |
| 5.7      | Bi-adjacent channel rejection<br>$\pm 3.456$ MHz                       | $BER < 10^{-3}$ , wanted at -76 dBm,<br>bi-adjacent level referred to wanted<br>channel level <sup>(1)</sup>         | $R_{i(N-2)}$      | 30   |            |                | dBc      |
| 5.8      | Rejection with $\geq 3$ channels<br>separation<br>$\geq \pm 5.128$ MHz | $BER < 10^{-3}$ , wanted at -76 dBm,<br>$n \geq 3$ adjacent level referred to<br>wanted channel level <sup>(1)</sup> | $R_{i(n \geq 3)}$ | 40   |            |                | dBc      |
| 5.9      | Out of band rejection > 6 MHz  | $BER < 10^{-3}$ , wanted at -83 dBm at<br>2.45 GHz <sup>(1)</sup>  | $BI_{df>6MHz}$    | 38   |            |                | dBc      |
| 5.10     | Out of band rejection<br>2300 MHz to 2394 MHz<br>2506 MHz to 2600 GHz  | $BER < 10^{-3}$ , wanted at -83 dBm at<br>2.45 GHz <sup>(1)</sup>  | $BI_{near}$       | 47   |            |                | dBc      |
| 5.11     | Out of band rejection<br>30 MHz to 2300 MHz<br>2600 MHz to 6 GHz       | $BER < 10^{-3}$ , wanted at -83 dBm at<br>2.45 GHz <sup>(1)</sup>  | $BI_{far}$        | 57   |            |                | dBc      |
| <b>6</b> | <b>RSSI Part</b>   |  |                   |      |            |                |          |
| 6.1      | Maximum RSSI output voltage  | Under high RX input signal level   | $V_{RSSImax}$     |      | 2.1        |                | V        |
| 6.2      | RSSI output voltage, monotonic<br>over range -96 dBm to -36 dBm        | With -33 dBm at RF input<br>With -96 dBm at RF input   | $V_{RSSI}$        |      | 1.9<br>0.1 |                | V<br>V   |
| <b>7</b> | <b>VCO</b>   |  |                   |      |            |                |          |
| 7.1      | Oscillator frequency defined at<br>TX output                           | Over full temperature range <sup>(1)</sup>   |                   | 2400 |            | 2483           | MHz      |
| 7.2      | Frequency control voltage range  |  | $V_{VTUNE}$       | 0.5  |            | $V_{CC} - 0.5$ | V        |
| 7.3      | VCO tuning input gain defined at<br>TX output                          |  | $G_{VCO}$         |      | 240        |                | MHz/V    |

- Notes:
1. Measured and guaranteed only on the Atmel® evaluation board, including microstrip filter, balun, and Smart Radio Frequency (Smart RF) firmware. Conducted measured.
  2. Timing is determined by external loop filter characteristics. Faster timing can be achieved by modification of the loop filter. For further information refer to the application notes.
  3. The Gaussian filter control setting (GFCS) is used to compensate production tolerances by tuning the modulation deviation in production to the nominal value of 400 kHz.
  4. Burst mode with 0.9% duty cycle



## 6. Electrical Characteristics (Continued)

$V_S = 3.6V$  with AUX regulator,  $T_{amb} = 25^\circ C$ , unless otherwise specified

| No.       | Parameters   | Test Conditions                       | Symbol              | Min.        | Typ.             | Max. | Unit             |
|-----------|--|---------------------------------------|---------------------|-------------|------------------|------|------------------|
| <b>8</b>  | <b>Synthesizer</b>   |                                       |                     |             |                  |      |                  |
| 8.1       | External reference input frequency   | D7 = 0<br>D7 = 1                      | REF_CLK             |             | 10.368<br>13.824 |      | MHz<br>MHz       |
| 8.2       | Sinusoidal input signal level (peak-to-peak value)                             | AC-coupled sine wave                  | REF_CLK             | 500         |                  | 1000 | mV <sub>pp</sub> |
| 8.3       | Scaling factor prescaler   |                                       | S <sub>PSC</sub>    | 32/33       |                  |      | -                |
| 8.4       | Scaling factor main counter  |                                       | S <sub>MC</sub>     | 86/87/88/89 |                  |      | -                |
| 8.5       | Scaling factor swallow counter   |                                       | S <sub>SC</sub>     | 0           |                  | 31   | -                |
| <b>9</b>  | <b>Phase Detector</b>  |                                       |                     |             |                  |      |                  |
| 9.1       | Phase detector comparison frequency  |                                       | f <sub>PD</sub>     |             | 1728             |      | kHz              |
| <b>10</b> | <b>Charge-pump Output</b>  |                                       |                     |             |                  |      |                  |
| 10.1      | Charge-pump output current   | V <sub>CP</sub> = 1/2 V <sub>CC</sub> | I <sub>CP</sub>     |             | ±2               |      | mA               |
| 10.2      | Leakage current  | V <sub>CP</sub> = 1/2 V <sub>CC</sub> | I <sub>L</sub>      |             | ±100             | 1000 | pA               |
| <b>11</b> | <b>Timing Conditions<sup>(1)(2)</sup></b>                                      |                                       |                     |             |                  |      |                  |
| 11.1      | Transmit to receive time   | Reference clock stable                | TX → RX time        |             | 200              |      | μs               |
| 11.2      | Receive to transmit time   | Reference clock stable                | RX → TX time        |             | 200              |      | μs               |
| 11.3      | Channel switch time  | Reference clock stable                | CS time             |             | 200              |      | μs               |
| 11.4      | Power down to transmit   | Reference clock stable                | PD → TR time        |             | 250              |      | μs               |
| 11.5      | Power down to receive  | Reference clock stable                | PD → RX time        |             | 200              |      | μs               |
| 11.6      | Programming register   | Reference clock stable                | PRR time            |             | 3                |      | μs               |
| 11.7      | PLL settling time  | Reference clock stable                | PLL set time        |             | 200              |      | μs               |
| <b>12</b> | <b>Interface Logic Input and Output Signal Levels, Pin DATA, CLOCK, ENABLE</b> |                                       |                     |             |                  |      |                  |
| 12.1      | HIGH-level input voltage   | Logic 1                               | V <sub>IH</sub>     | 1.4         |                  | 3.1  | V                |
| 12.2      | LOW-level input voltage  | Logic 0                               | V <sub>IL</sub>     | -0.3        |                  | +0.4 | V                |
| 12.3      | HIGH-level output voltage  | Logic 1                               | V <sub>OH</sub>     |             |                  | 3.1  | V                |
| 12.4      | LOW-level output voltage   | Logic 0                               | V <sub>OL</sub>     | 0           |                  |      | V                |
| 12.5      | Input bias current   | Logic 1 or logic 0                    | I <sub>bias</sub>   | -5          |                  | +5   | μA               |
| 12.6      | 3-wire bus clock frequency   |                                       | f <sub>CLKmax</sub> |             |                  | 10   | MHz              |

- Notes:
1. Measured and guaranteed only on the Atmel® evaluation board, including microstrip filter, balun, and Smart Radio Frequency (Smart RF) firmware. Conducted measured.
  2. Timing is determined by external loop filter characteristics. Faster timing can be achieved by modification of the loop filter. For further information refer to the application notes.
  3. The Gaussian filter control setting (GFCS) is used to compensate production tolerances by tuning the modulation deviation in production to the nominal value of 400 kHz.
  4. Burst mode with 0.9% duty cycle



## 7. PLL Principle

Figure 7-1. PLL Principle

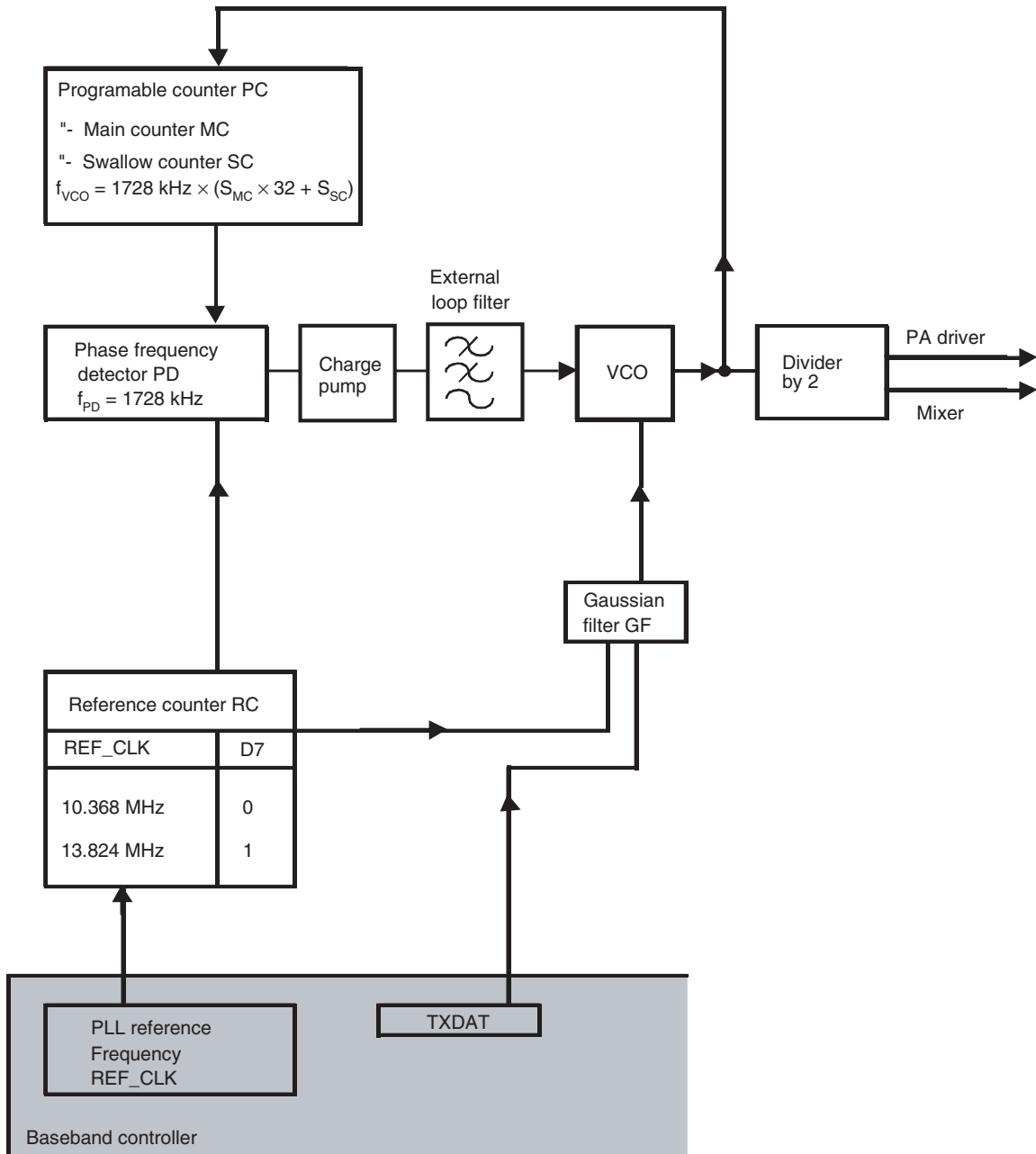


Table 7-1 shows the LO frequencies for RX and TX in the 2.4-GHz ISM band. There are 95 channels available. Since the ATR2406 supports wideband modulation with 400-kHz deviation, every second channel can be used without overlap in the spectrum.

**Table 7-1.** LO Frequencies

| Mode | $f_{IF}$ / kHz | Channel | $f_{ANT}$ / MHz | $f_{VCO}$ / MHz divided by 2 | $S_{MC}$ | $S_{SC}$ | N    |
|------|----------------|---------|-----------------|------------------------------|----------|----------|------|
| TX   |                | C0      | 2401.056        | 2401.056                     | 86       | 27       | 2779 |
|      |                | C1      | 2401.920        | 2401.920                     | 86       | 28       | 2780 |
|      |                | ...     | ...             | ...                          | ...      | ...      | ...  |
|      |                | C93     | 2481.408        | 2481.408                     | 89       | 24       | 2872 |
|      |                | C94     | 2482.272        | 2482.272                     | 89       | 25       | 2873 |
| RX   | 864            | C0      | 2401.056        | 2401.920                     | 86       | 28       | 2780 |
|      |                | C1      | 2401.920        | 2402.784                     | 86       | 29       | 2781 |
|      |                | ...     | ...             | ...                          | ...      | ...      | ...  |
|      |                | C93     | 2481.408        | 2482.272                     | 89       | 25       | 2873 |
|      |                | C94     | 2482.272        | 2483.136                     | 89       | 26       | 2874 |

## 7.1 TX Register Setting

The following 16-bit word has to be programmed for TX.

| MSB       |     |     |     |      |     |    |    |    |    |    |    |    |    |    | LSB |
|-----------|-----|-----|-----|------|-----|----|----|----|----|----|----|----|----|----|-----|
| Data bits |     |     |     |      |     |    |    |    |    |    |    |    |    |    |     |
| D15       | D14 | D13 | D12 | D11  | D10 | D9 | D8 | D7 | D6 | D5 | D4 | D3 | D2 | D1 | D0  |
| 0         | 1   | PA  |     | GFCS |     |    | 1  | RC | MC |    | SC |    |    |    |     |

Note: D12 and D13 are only relevant if ramping generator in conjunction with external PA is used, otherwise it can be programmed 0 or 1.

**Table 7-2.** Output Power Settings with Bits D12 - D13

| PA (Output Power Settings) |     |                   |
|----------------------------|-----|-------------------|
| D13                        | D12 | RAMP_OUT (Pin 21) |
| 0                          | 0   | 1.3V              |
| 0                          | 1   | 1.35V             |
| 1                          | 0   | 1.4V              |
| 1                          | 1   | 1.75V             |

The VRAMP voltage is used to control the output power of an external power amplifier. The voltage ramp is started with the TX\_ON signal.

These bits are only relevant in TX mode.

## 7.2 RX Register Setting

There are two RX settings possible. For a data rate of 1152 kBits/s, an internal clock recovery function is implemented.

## 7.3 Register Setting Without Clock Recovery

Must be used for data rates below 1.152 Mbits/s.

|           |     |     |     |     |     |    |    |    |    |    |    |    |    |    |     |
|-----------|-----|-----|-----|-----|-----|----|----|----|----|----|----|----|----|----|-----|
| MSB       |     |     |     |     |     |    |    |    |    |    |    |    |    |    | LSB |
| Data bits |     |     |     |     |     |    |    |    |    |    |    |    |    |    |     |
| D15       | D14 | D13 | D12 | D11 | D10 | D9 | D8 | D7 | D6 | D5 | D4 | D3 | D2 | D1 | D0  |
| 0         | 1   | X   | X   | X   | X   | X  | 0  | RC | MC |    | SC |    |    |    |     |

Note: X values are not relevant and can be set to 0 or 1.

## 7.4 RX Register Setting with Internal Clock Recovery

Recommended for 1.152-Mbit/s data rate.

The output pin of the recovered clock is pin 6. The falling edge of the recovered clock signal samples the data signal.

|           |     |     |     |     |     |     |     |     |
|-----------|-----|-----|-----|-----|-----|-----|-----|-----|
| MSB       |     |     |     |     |     |     |     |     |
| Data bits |     |     |     |     |     |     |     |     |
| D24       | D23 | D22 | D21 | D20 | D19 | D18 | D17 | D16 |
| 1         | 0   | 1   | 0   | 0   | 0   | 0   | 0   | 0   |

|           |     |     |     |     |     |    |    |    |    |    |    |    |    |    |     |
|-----------|-----|-----|-----|-----|-----|----|----|----|----|----|----|----|----|----|-----|
|           |     |     |     |     |     |    |    |    |    |    |    |    |    |    | LSB |
| Data bits |     |     |     |     |     |    |    |    |    |    |    |    |    |    |     |
| D15       | D14 | D13 | D12 | D11 | D10 | D9 | D8 | D7 | D6 | D5 | D4 | D3 | D2 | D1 | D0  |
| 0         | 0   | X   | X   | X   | X   | X  | 0  | RC | MC |    | SC |    |    |    |     |

Note: X values are not relevant and can be set to 0 or 1.

## 7.5 PLL Settings

RC, MC and SC bits control the synthesizer frequency as shown in [Table 7-3](#), [Table 7-4 on page 12](#) and [Table 7-5 on page 12](#).

### Formula for calculating the frequency:

$$\text{TX frequency: } f_{\text{ANT}} = 864 \text{ kHz} \times (32 \times S_{\text{MC}} + S_{\text{SC}})$$

$$\text{RX frequency: } f_{\text{ANT}} = 864 \text{ kHz} \times (32 \times S_{\text{MC}} + S_{\text{SC}} - 1)$$

**Table 7-3.** PLL Settings of the Reference Counter Bit D7

| RC (Reference Counter) |               |
|------------------------|---------------|
| D7                     | CLK Reference |
| 0                      | 10.368 MHz    |
| 1                      | 13.824 MHz    |

**Table 7-4.** PLL Settings of the Main Counter Bits D5 to D6

| MC (Main Counter) |    |                 |
|-------------------|----|-----------------|
| D6                | D5 | S <sub>MC</sub> |
| 0                 | 0  | 86              |
| 0                 | 1  | 87              |
| 1                 | 0  | 88              |
| 1                 | 1  | 89              |

**Table 7-5.** PLL Settings of the Swallow Counter Bits D0 to D4

| SC (Swallow Counter) |     |     |     |     |                 |
|----------------------|-----|-----|-----|-----|-----------------|
| D4                   | D3  | D2  | D1  | D0  | S <sub>SC</sub> |
| 0                    | 0   | 0   | 0   | 0   | 0               |
| 0                    | 0   | 0   | 0   | 1   | 1               |
| 0                    | 0   | 0   | 1   | 0   | 2               |
| ...                  | ... | ... | ... | ... | ...             |
| 1                    | 1   | 1   | 0   | 1   | 29              |
| 1                    | 1   | 1   | 1   | 0   | 30              |
| 1                    | 1   | 1   | 1   | 1   | 31              |

## 7.6 GFCS Adjustment

The Gaussian filter control setting (GFCS) is used to compensate for production tolerances by tuning the modulation deviation in production to the nominal value of 400 kHz. These bits are only relevant in TX mode.

**Table 7-6.** GFCS Adjustment of Bits D9 - D11

| GFCS |     |    |      |
|------|-----|----|------|
| D11  | D10 | D9 | GFCS |
| 0    | 0   | 0  | 60%  |
| 0    | 0   | 1  | 70%  |
| 0    | 1   | 0  | 80%  |
| 0    | 1   | 1  | 90%  |
| 1    | 0   | 0  | 100% |
| 1    | 0   | 1  | 110% |
| 1    | 1   | 0  | 120% |
| 1    | 1   | 1  | 130% |

## 7.7 Control Signals

The various transceiver functions are activated by the following control signals. A timing proposal is shown in [Figure 7-3 on page 14](#)

**Table 7-7.** Control Signals and Functions

| Signal | Functions  |
|--------|--|
| PU_REG | Activates AUX voltage regulator and the VCO voltage regulator supplying the complete transceiver |
| PU_TRX | Activates RX/TX blocks   |
| RX_ON  | Activates RX circuits: DEMOD, IF AMP, IR MIXER   |
| TX_ON  | Activates TX circuits: PA, RAMP GEN, Starts RAMP SIGNAL at RAMP_OUT                              |
| nOLE   | Disables open loop mode of the PLL   |

## 7.8 Serial Programming Bus

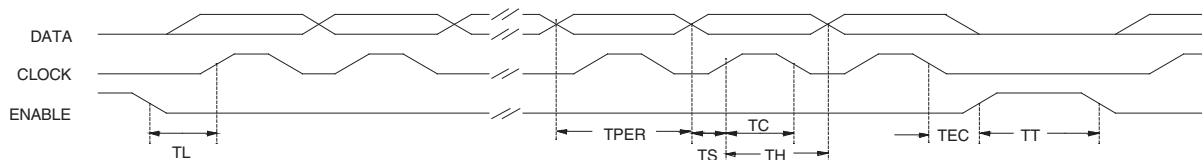
The transceiver is programmed by the SPI (CLOCK, DATA and ENABLE).

After setting the enable signal to low, the data is transferred bit by bit into the shift register on the rising edge of the clock signal, starting with the MSBit. When the enable signal has returned to high, the programmed information is active. Additional leading bits are ignored and there is no check made of how many clock pulses arrived during enable low.

The programming of the transceiver is done by a 16-bit or 25-bit data word (for the RX clock recovery mode).

## 7.9 3-wire Bus Timing

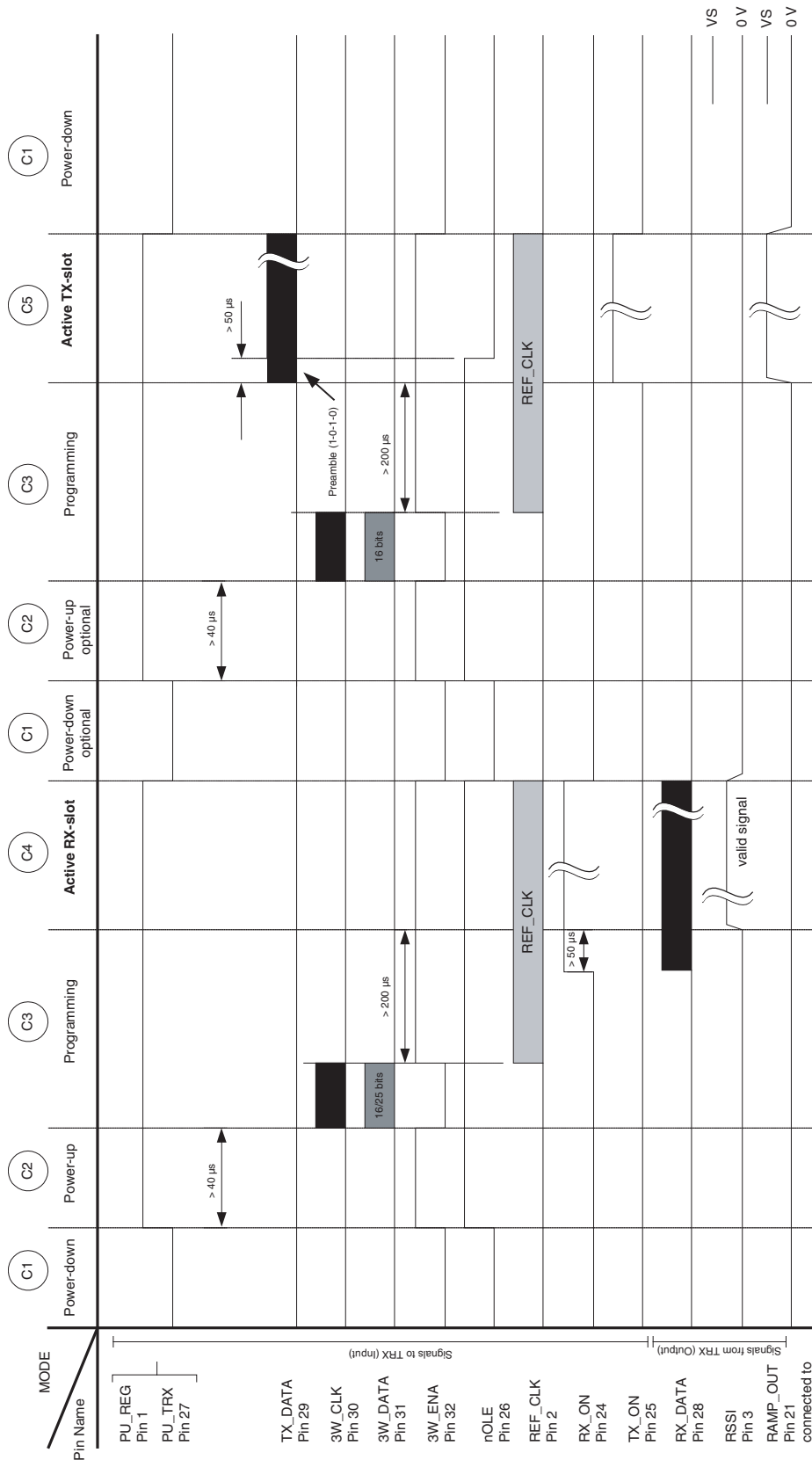
**Figure 7-2.** 3-wire Bus Protocol Timing Diagram



**Table 7-8.** 3-wire Bus Protocol Table

| Description                | Symbol | Minimum Value | Unit |
|----------------------------|--------|---------------|------|
| Clock period               | TPER   | 100           | ns   |
| Set time data to clock     | TS     | 20            | ns   |
| Hold time data to clock    | TH     | 20            | ns   |
| Clock pulse width          | TC     | 60            | ns   |
| Set time enable to clock   | TL     | 100           | ns   |
| Hold time enable to data   | TEC    | 0             | ns   |
| Time between two protocols | TT     | 250           | ns   |

Figure 7-3. Example TX and RX Timing Diagram



Note: 1. Keep input signals on low level during power-down state of TRX

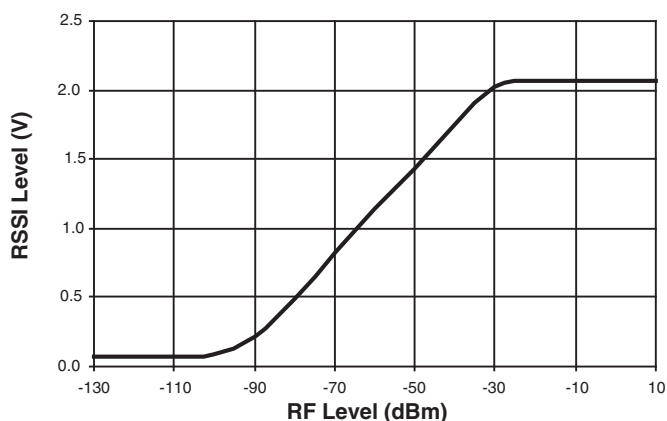
**Table 7-9.** Description of the Conditions/States

| Condition | Description   |
|-----------|---|
| C1        | Power down<br>ATR2406 is switched off and the supply current is lower than 1 $\mu$ A.   |
| C2        | Power up<br>ATR2406 is powered up by toggling PU_REG and PU_TRX to high. PU_REG enables the external AUX regulator transistor including VCO regulator. PU_TRX enables internal blocks like the PLL and the VCO. Depending on the value of the external capacitors (for example, at the AUX regulator, if one is used), it is necessary to wait at least 40 $\mu$ s until the different supply voltages have settled.  |
| C3        | Programming<br>The internal register of the ATR2406 is programmed via the three-wire interface. At TX, this is just the PLL (transmit channel) and the deviation (Gaussian filter). At RX, this is just the PLL (receive channel) and, if the clock recovery is used, also the bits to enable this option. At the start of the three-wire programming, the enable signal is toggled from high to low to enable clocking the data into the internal register. When the enable signal rises again to high, the programmed data is latched. This is the time point at which the settling of the PLL starts. It is necessary to wait the settling time of 200 $\mu$ s so that the VCO frequency is stable. The reference clock needs to be applied to ATR2406 for at least the time when the PLL is in operation, which is the programming state (C3) and the active slot (C4, C5). Out of the reference clock, several internal signals are also derived, for example, the Gaussian filter circuitry and TX_DATA sampling. |
| C4        | This is the receive slot where the transmit burst is received and data as well as recovered clock are available.  |
| C5        | This is the active transmit slot. As soon as TX_DATA is applied to ATR2406, the signal nOLE toggles to low which enables modulation in open-loop mode. The preamble (1-0-1-0 pattern) should start being sent at the start of TX_ON.  |

## 7.10 Received Signal Strength Indication (RSSI)

The RSSI is given as an analog voltage at the RSSI pin. A typical plot of the RSSI value is shown in [Figure 7-4](#).

**Figure 7-4.** Typical RSSI Value versus Input Power

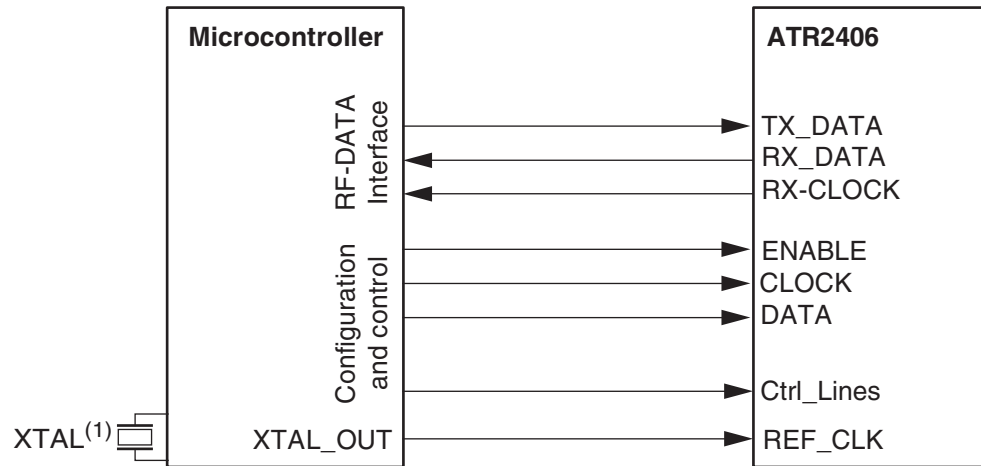


## 8. Application Circuit

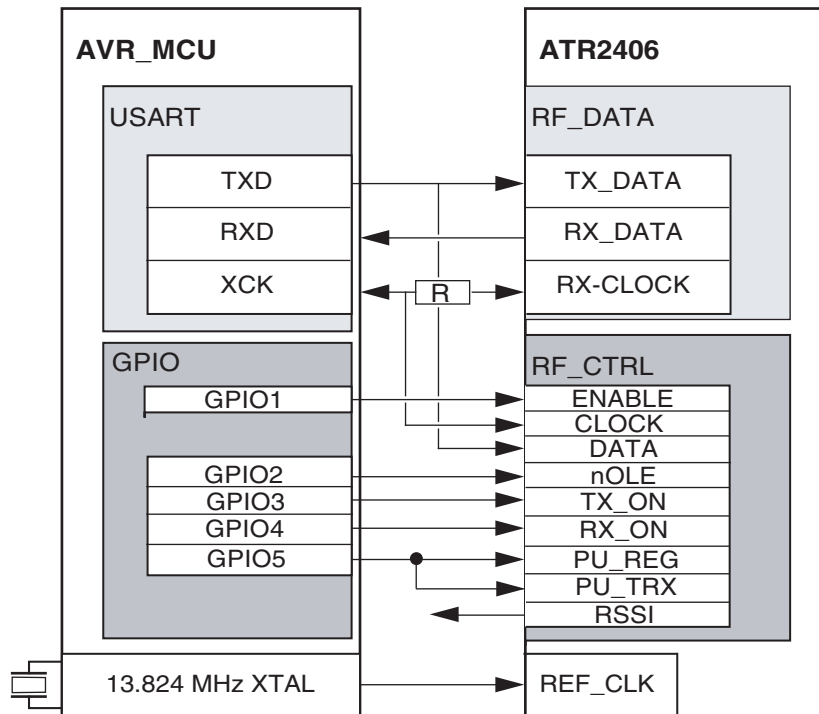
The ATR2406 requires only a few low-cost external components for operation. A typical application is shown in [Figure 8-3 on page 17](#).

### 8.1 Typical Application Circuit

**Figure 8-1.** Microcontroller Interfacing with General Purpose MCU, Pin Connections between Microcontroller and ATR2406



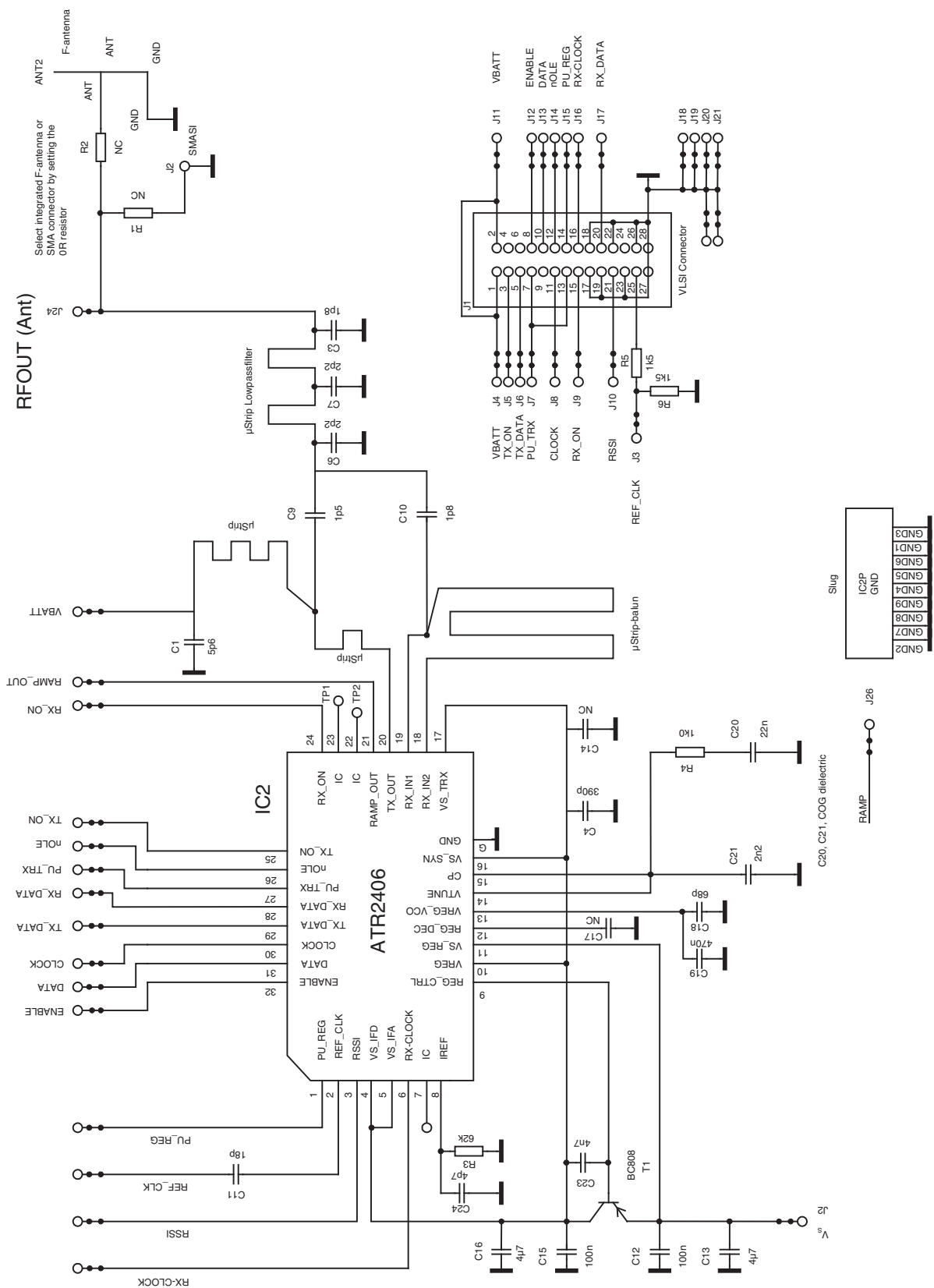
**Figure 8-2.** Example with AVR MCU



Note: 1. XTAL: for example, XRFBCC-NANL; 13.824 MHz, 10 ppm  
Order at: Taitien Electronic, Taitien Specific No.: A009-x-B26-3, SMD

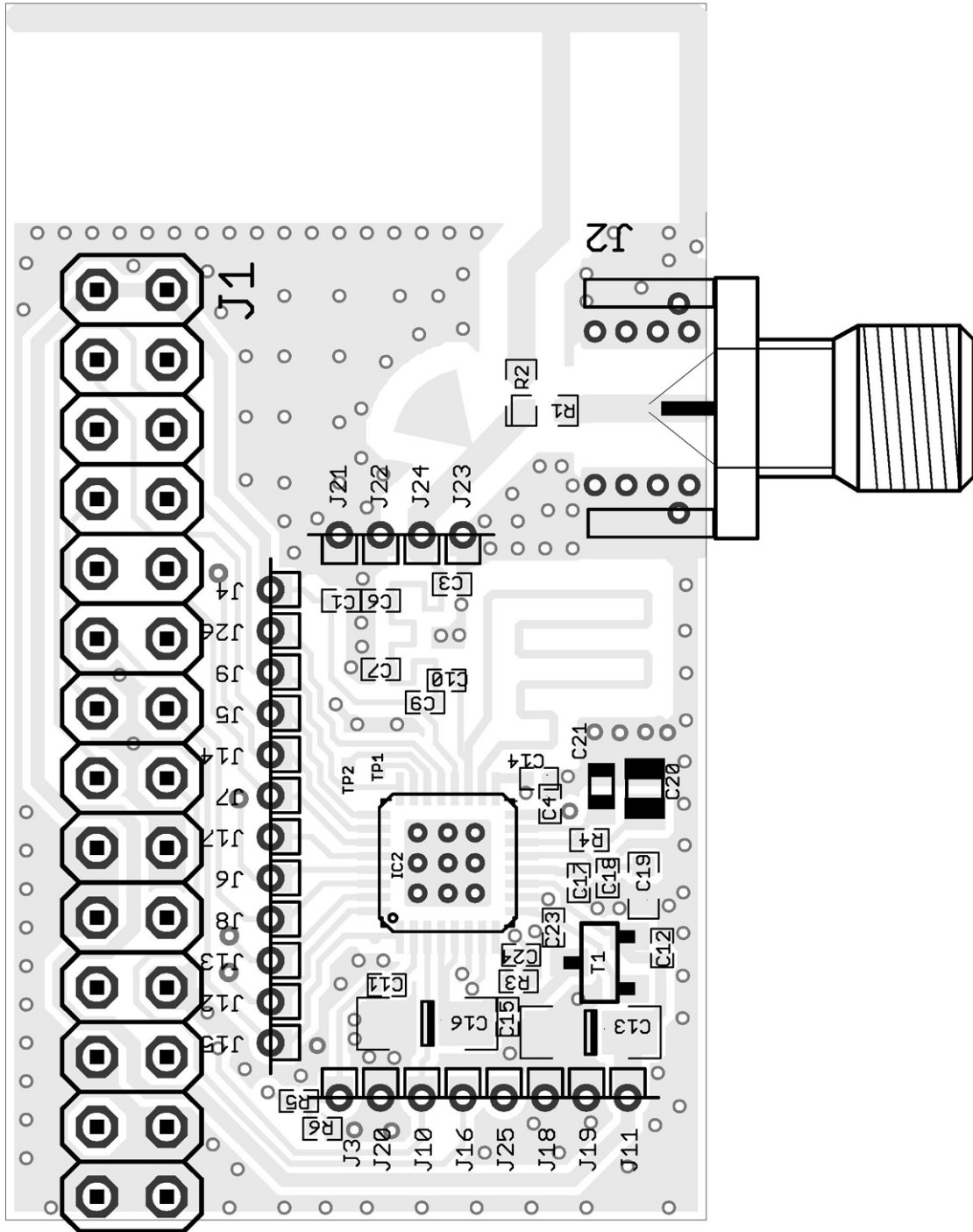


**Figure 8-3.** Application Circuit for ATR2406-DEV-BOARD



## 9. PCB Layout Design

Figure 9-1. PCB Layout ATR2406-DEV-BOARD



**Table 9-1.** Bill of Materials

| Part     | Value          | Part Number  | Vendor  | Package   | Comment                                |
|----------|----------------|--|---|-----------|--|
| C1       | 5.6 pF         |  |   | 0402      |  |
| C3, C10  | 1.8 pF         |  |   | 0402      |  |
| C4       | 390 pF         |  |   | 0402      |  |
| C5       | 4.7 pF         |  |   | 0402      | NC                                     |
| C6, C7   | 2.2 pF         |  |   | 0402      |  |
| C9       | 1.5 pF         |  |   | 0402      |  |
| C11      | 18 pF          |  |   | 0402      |  |
| C12, C15 | 100 nF         |  |   | 0402      |  |
| C13, C16 | 4.7 $\mu$ F    | B45196H2475M109  | Epcos <sup>®</sup>                                | 3216      | Optional <sup>(2)</sup>                |
| C14      | 1 nF           |  |   | 0402      | NC                                     |
| C17      | 3.3 nF         |  |   | 0402      | NC                                     |
| C18      | 68 pF          |  |   | 0402      |  |
| C19      | 470 nF         |  |   | 0402/0603 |  |
| C20      | 22 nF, COG     | GRM21B5C1H223JA01  | Murata  | 0805      | COG, important for good RF performance |
| C21      | 2.2 nF, COG    | GRM1885C1H222JA01  | Murata  | 0603      | COG, important for good RF performance |
| C23      | 4.7 nF         |  |   | 0402      |  |
| C24      | 4.7 pF         |  |   | 0402      |  |
| R3       | 62 k $\Omega$  | 62k, $\leq$ 5%   |   | 0402      |  |
| R4       | 1.0 k $\Omega$ | 1k0, $\leq$ 5%   |   | 0402      |  |
| R5       | 1.5 k $\Omega$ | 1k5, $\leq$ 5%   |   | 0402      | Ref_Clk level, optional <sup>(1)</sup> |
| R6       | 1.5 k $\Omega$ | 1k5, $\leq$ 5%   |   | 0402      | Ref_Clk level, optional <sup>(1)</sup> |
| IC2      | ATR2406        | ATR2406  | Atmel   | MLF32     |  |
| T1       | BC808-40       | BC808-40, any standard type can be used, but it is important that be “-40”!  | Vishay <sup>®</sup> , Philips <sup>®</sup> , etc. | SOT-23    | Optional <sup>(2)</sup>                |
| MSUB     | FR4            | FR4, e_r = 4.4 at 2.45 GHz, H = 500 $\mu$ m, T = 35 $\mu$ m, t_and = 0.02, surface, that is, chem. tin or chem. gold |   |           |  |

- Notes:
1. Not necessary if supplied RefClk level is within specification range
  2. If no AUX regulator is used, then T1 and C16 can be removed and a jumper is needed from the collector to the emitter pad. Additionally, pin 7 of the ATR2406 has to be connected to pin 4 or pin 5 to use the integrated F antenna, set jumper R2 (0R resistor 0603)

**Table 9-2.** Parts Count Bill of Materials

| Parts Count      | Required (Minimal BOM) | Optional (Depending on Application) |
|------------------|------------------------|-------------------------------------|
| Capacitors 0402  | 14                     | 14                                  |
| Capacitors >0402 | 2                      | 4                                   |
| Resistors 0402   | 2                      | 2                                   |
| Inductors 0402   | –                      | –                                   |
| Semiconductors   | 1                      | 2                                   |

## 10. Appendix: Current Calculations for a Remote Control

### Assumptions:

|                     |   |
|---------------------|---|
| Protocol            | A data packet consists of 24 bytes.<br>24 bytes = 240 bits (USART connection)<br>$T_{\text{packet\_length}} = 210 \mu\text{s}$ at 1.152 Mbits/s   |
| Channel             | The system will use five predefined channels for frequency hopping spread spectrum (FHSS) which gives improved immunity against interferers   |
| Loop filter         | Loop filter settling time will be 110 $\mu\text{s}$   |
| Handheld device     | If not in use, the handheld device will be in power-down mode with the AVR's watchdog timer disabled. The AVR power-down current is typically 1.25 $\mu\text{A}$ . If an external voltage regulator is used, additional power-down current has to be taken into account   |
| Base station device | The base station will periodically scan all the channels of the used subset. The base station will stay on one channel for 2 seconds. If the base station receives a correct packet, an acknowledge will be returned to the handheld device. The power consumption of the base station device is not power-sensitive, as this part of the application is normally mains powered |

### Basic Numbers:

|  |                    |
|--|--------------------|
| Peak current ATR2406 in TX at 1.152 Kbits/s          | 42 mA              |
| Peak current ATR2406 in RX at 1.152 Kbits/s          | 57 mA              |
| Peak current ATR2406 with synthesizer running        | 26 mA              |
| Current ATmega88 active                              | 5 mA               |
| Current ATmega88 power down (no WDT)                 | 1.25 $\mu\text{A}$ |
| Current ATmega88 power down (+ WDT)                  | 5 $\mu\text{A}$    |
| Loop settling time of ATR2406                        | 110 $\mu\text{s}$  |
| Configuration of ATR2406                             | 30 $\mu\text{s}$   |
| Time needed for exchanging a packet at 1.152 Kbits/s | 210 $\mu\text{s}$  |

### Amount of Current Needed to Transmit One Packet:

|  |
|--|
| $Q1 = (0.005\text{A} + 0.026\text{A}) \times 5030 \mu\text{s} = 155 \mu\text{As}$ (charge up time ATR2406 + AVR internal calculations) |
| $Q2 = (0.005\text{A} + 0.026\text{A}) \times 30 \mu\text{s} = 0.93 \mu\text{As}$ (charge for configuring the ATR2406)                  |
| $Q3 = (0.005\text{A} + 0.026\text{A}) \times 110 \mu\text{s} = 3.41 \mu\text{As}$ (charge for settling the loop filter)                |
| $Q4 = (0.005\text{A} + 0.042\text{A}) \times 210 \mu\text{s} = 9.87 \mu\text{As}$ (charge for transmitting the packet)                 |
| $Q5 = (0.005\text{A}) \times 250 \mu\text{s} = 1.25 \mu\text{As}$ (charge for turn around (TX to RX, RX to TX, etc.))                  |
| $Q6 = (0.005\text{A} + 0.026\text{A}) \times 30 \mu\text{s} = 0.93 \mu\text{As}$ (charge for configuring the ATR2406)                  |
| $Q7 = (0.005\text{A} + 0.026\text{A}) \times 60 \mu\text{s} = 1.86 \mu\text{As}$ (charge for settling the loop filter)                 |
| $Q8 = (0.005\text{A} + 0.057\text{A}) \times 50 \mu\text{s} = 3.10 \mu\text{As}$ (charge until valid data can be received)             |
| $Q9 = (0.005\text{A} + 0.057\text{A}) \times 210 \mu\text{s} = 13.02 \mu\text{As}$ (charge for receiving the packet)                   |
| $Q10 = (0.005\text{A} + 0.057\text{A}) \times 50 \mu\text{s} = 3.1 \mu\text{As}$ (charge for latency before receiving)                 |

A successful packet exchange needs the following charge

$$Q = Q1 + Q2 + Q3 + Q4 + Q5 + Q6 + Q7 + Q8 + Q9 + Q10 = 192.47 \mu\text{As}$$

As the described system is a FHSS system with 5 different channels, the system has to do this up to five times before the packet is acknowledged by the base station. The average will be 2.5 times. In the case of an interfered environment, some more retries may be required; therefore, it is assumed the factor will be 3. The power-up time is included only once, as the cycle will be completed without powering up and down the handheld in order to be as power efficient as possible.

Average current needed for a packet exchange:

$$155 \mu\text{As} + (37.5 \mu\text{As} \times 3) = 267.5 \mu\text{As}$$

If the device will be used 1000 times a day  $\rightarrow 3.1 \mu\text{A}$

Average current in active mode:

$\rightarrow$  System Power Down current:

Current ATmega88: 1.25  $\mu\text{A}$

Current ATR2406: 1.0  $\mu\text{A}$

Current VREG (+ ShutDown): 2.75  $\mu\text{A}$

Assumed average power-down current is 5  $\mu\text{A}$ .

$\rightarrow$  Overall power consumption is 8.1  $\mu\text{A}$

It is assumed the system uses a small battery with a capacity of 100 mAh. This is 100.000  $\mu\text{Ah}$ .

$\rightarrow$  Battery lifetime will be around: 12345 hours = 514 days = 1.4 years.

**The most important factor is to get the power-down current as low as possible!**

Example:

Assume a system where the handheld is used just 10 times per day.

$$\rightarrow I_{\text{active}} = 0.031 \mu\text{A}$$

and assuming the power-down current of this device is just 4  $\mu\text{A}$ .

$$\rightarrow I = 0.031 \mu\text{A} + 4 \mu\text{A} = 4.03 \mu\text{A}$$

$\rightarrow$  Battery lifetime will be around 24807 hours = 1033 days = 2.83 years.

$\rightarrow$  Power-down current is the main factor influencing the battery lifetime.

## 11. Ordering Information

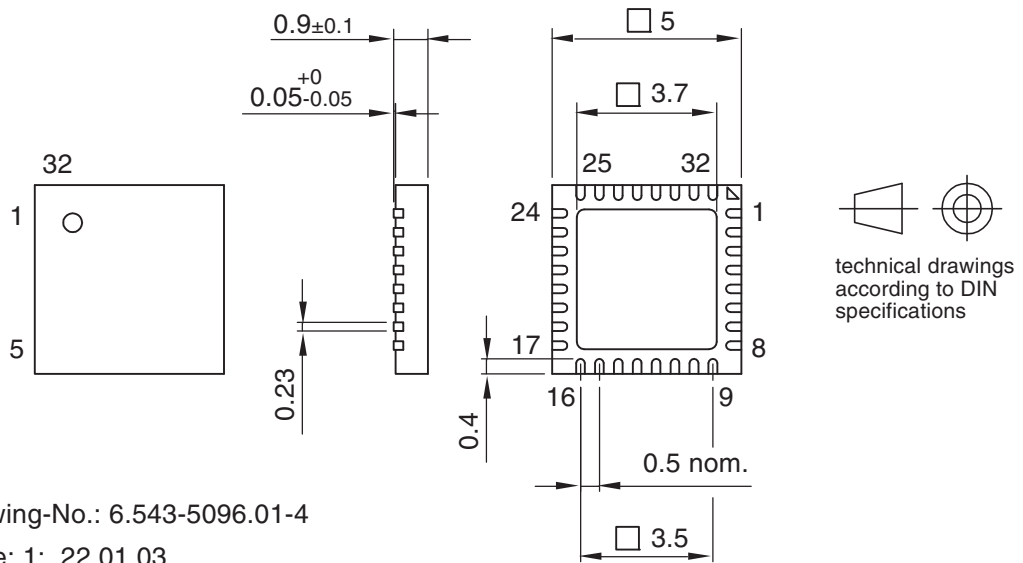
| Extended Type Number | Package     | Remarks  | MOQ  |
|----------------------|-------------|--|------|
| ATR2406-PNQG         | QFN32 - 5x5 | Taped and reeled, Pb-free  | 4000 |
| ATR2406-DEV-BOARD    | -           | RF module  | 1    |
| ATR2406-DEV-KIT2     | -           | Complete evaluation kit and reference design<br>ATR2406 + ATmega88 | 1    |

## 12. Package Information

Package: QFN 32 - 5 x 5  
Exposed pad 3.7 x 3.7

Dimensions in mm

Not indicated tolerances  $\pm 0.05$



Drawing-No.: 6.543-5096.01-4

Issue: 1; 22.01.03

### 13. Recommended Footprint/Landing Pattern

Figure 13-1. Recommended Footprint/Landing Pattern

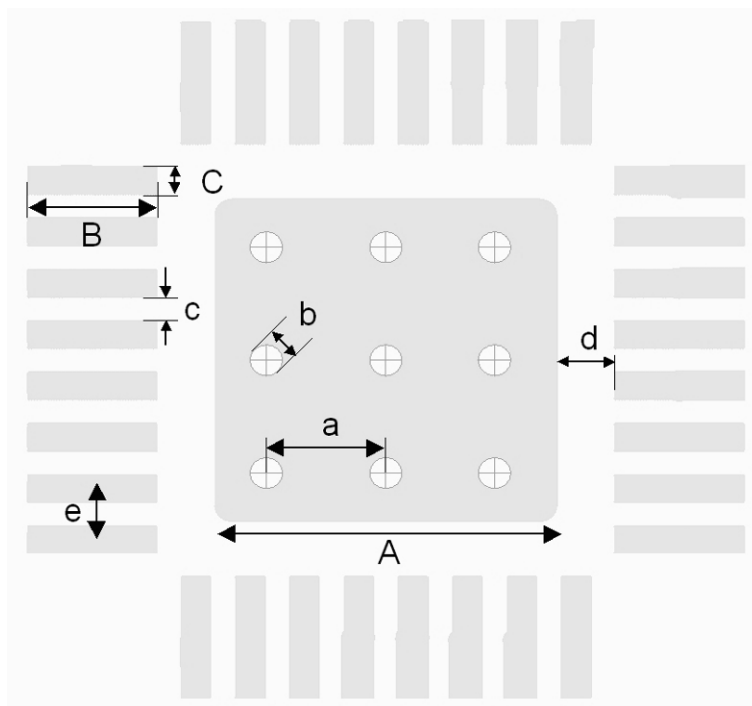


Table 13-1. Recommended Footprint/Landing Pattern Signs

| Sign | Size    |
|------|---------|
| A    | 3.2 mm  |
| B    | 1.2 mm  |
| C    | 0.3 mm  |
| a    | 1.1 mm  |
| b    | 0.3 mm  |
| c    | 0.2 mm  |
| d    | 0.55 mm |
| e    | 0.5 mm  |

## 14. Revision History

Please note that the following page numbers referred to in this section refer to the specific revision mentioned, not to this document.

| Revision No.    | History   |
|-----------------|---|
| 4779N-ISM-12/08 | <ul style="list-style-type: none"> <li>• Put datasheet in a new template</li> <li>• Section 12 “Package Information” on page 22 changed</li> </ul>  |
| 4779M-ISM-02/07 | <ul style="list-style-type: none"> <li>• Put datasheet in a new template</li> <li>• Table 9-1 “Bill of Materials” on page 19 changed</li> </ul>   |
| 4779L-ISM-08/06 | <ul style="list-style-type: none"> <li>• Table “Electrical Characteristics” on pages 6 to 8 changed</li> <li>• Section 10 “Appendix: Current Calculations for a Remote Control” on pages 20 to 21 changed</li> <li>• Table “Ordering Information” on page 22 changed</li> <li>• Minor corrections to grammar and style throughout document</li> </ul> |
| 4779K-ISM-06/06 | <ul style="list-style-type: none"> <li>• Put datasheet in a new template</li> <li>• Table “Electrical Characteristics” on pages 6 to 8 changed</li> <li>• Section 10 “Appendix: Current Calculations for a Remote Control” on pages 20 to 21 added</li> <li>• Ordering Information on page 22 changed</li> </ul>                                      |





## Headquarters

---

**Atmel Corporation**  
2325 Orchard Parkway  
San Jose, CA 95131  
USA  
Tel: 1(408) 441-0311  
Fax: 1(408) 487-2600

## International

---

**Atmel Asia**  
Unit 1-5 & 16, 19/F  
BEA Tower, Millennium City 5  
418 Kwun Tong Road  
Kwun Tong, Kowloon  
Hong Kong  
Tel: (852) 2245-6100  
Fax: (852) 2722-1369

**Atmel Europe**  
Le Krebs  
8, Rue Jean-Pierre Timbaud  
BP 309  
78054  
Saint-Quentin-en-Yvelines Cedex  
France  
Tel: (33) 1-30-60-70-00  
Fax: (33) 1-30-60-71-11

**Atmel Japan**  
9F, Tonetsu Shinkawa Bldg.  
1-24-8 Shinkawa  
Chuo-ku, Tokyo 104-0033  
Japan  
Tel: (81) 3-3523-3551  
Fax: (81) 3-3523-7581

## Product Contact

---

**Web Site**  
[www.atmel.com](http://www.atmel.com)

**Technical Support**  
[cordless\\_phone@atmel.com](mailto:cordless_phone@atmel.com)

**Sales Contact**  
[www.atmel.com/contacts](http://www.atmel.com/contacts)

**Literature Requests**  
[www.atmel.com/literature](http://www.atmel.com/literature)

---

**Disclaimer:** The information in this document is provided in connection with Atmel products. No license, express or implied, by estoppel or otherwise, to any intellectual property right is granted by this document or in connection with the sale of Atmel products. **EXCEPT AS SET FORTH IN ATMEL'S TERMS AND CONDITIONS OF SALE LOCATED ON ATMEL'S WEB SITE, ATMEL ASSUMES NO LIABILITY WHATSOEVER AND DISCLAIMS ANY EXPRESS, IMPLIED OR STATUTORY WARRANTY RELATING TO ITS PRODUCTS INCLUDING, BUT NOT LIMITED TO, THE IMPLIED WARRANTY OF MERCHANTABILITY, FITNESS FOR A PARTICULAR PURPOSE, OR NON-INFRINGEMENT. IN NO EVENT SHALL ATMEL BE LIABLE FOR ANY DIRECT, INDIRECT, CONSEQUENTIAL, PUNITIVE, SPECIAL OR INCIDENTAL DAMAGES (INCLUDING, WITHOUT LIMITATION, DAMAGES FOR LOSS OF PROFITS, BUSINESS INTERRUPTION, OR LOSS OF INFORMATION) ARISING OUT OF THE USE OR INABILITY TO USE THIS DOCUMENT, EVEN IF ATMEL HAS BEEN ADVISED OF THE POSSIBILITY OF SUCH DAMAGES.** Atmel makes no representations or warranties with respect to the accuracy or completeness of the contents of this document and reserves the right to make changes to specifications and product descriptions at any time without notice. Atmel does not make any commitment to update the information contained herein. Unless specifically provided otherwise, Atmel products are not suitable for, and shall not be used in, automotive applications. Atmel's products are not intended, authorized, or warranted for use as components in applications intended to support or sustain life.

© 2008 Atmel Corporation. All rights reserved. Atmel®, Atmel logo and combinations thereof, AVR® and others are registered trademarks or trademarks of Atmel Corporation or its subsidiaries. Other terms and product names may be trademarks of others.

# Mouser Electronics

Authorized Distributor

Click to View Pricing, Inventory, Delivery & Lifecycle Information:

[Atmel:](#)

[ATR2406-PNQG86](#) [ATR2406-DEV-BOARD](#) [ATR2406-DEV-BOARD2](#) [ATR2406-DEV-KIT2](#)