

ACT5101-1 HIGH VOLTAGE 3-PHASE BRUSHLESS DC MOTOR DRIVE

Features

- 500 VDC RATING
- 40 AMP CONTINUOUS CURRENT (UP TO 85°C)
- PACKAGE SIZE 3.0" X 2.1" X 0.39"
- 4 QUADRANT CONTROL
- 6 STEP TRAPEZOIDAL DRIVE CAPABILITY
- MILITARY PROCESSING AVAILABLE
- MIL-PRF-38534 COMPLIANT CIRCUITS AVAILABLE
- ISOLATED UPPER AND LOWER GATE DRIVERS
- FULL MILITARY (-55°C TO +125°C) TEMPERATURE RANGE

AEROFLEX
CIRCUIT TECHNOLOGY
www.aeroflex.com

General Description

The ACT5101-1 high voltage 3 phase brushless DC motor drive combines a 500 VDC, 40A high power output stage along with low power digital input and gate drive stages. A digital lock-out feature protects the output stage from accidental cross-conduction thus preventing shoot-through conditions. The ACT5101-1 also includes a floating gate drive design for each upper and lower transistor. On-board gate drive supplies provide a continuous floating voltage for each upper and lower transistor, even during a motor stall.

The high power output stage rated at 500 VDC, 40A is capable of delivering over 20 kW to the load even after derating. This is accomplished through the use of high power IGBTs with ultra-fast recovery rectifiers in parallel.

The ACT5101-1 utilizes power hybrid technology to provide the highest levels of reliability and lightest weight while requiring the smallest amount of board space. The ACT5101-1 is available with military processing and operates over the full -55 to +125 degrees C temperature range.

This makes the ACT5101-1 ideal for all military, space, and commercial avionics' applications. These include electro-hydrostatic actuators (EHA's) and electro-mechanical actuators (EMA's) for flight surface control, missile fin actuators, thrust vector control, electric brakes, fuel and cooling pumps.

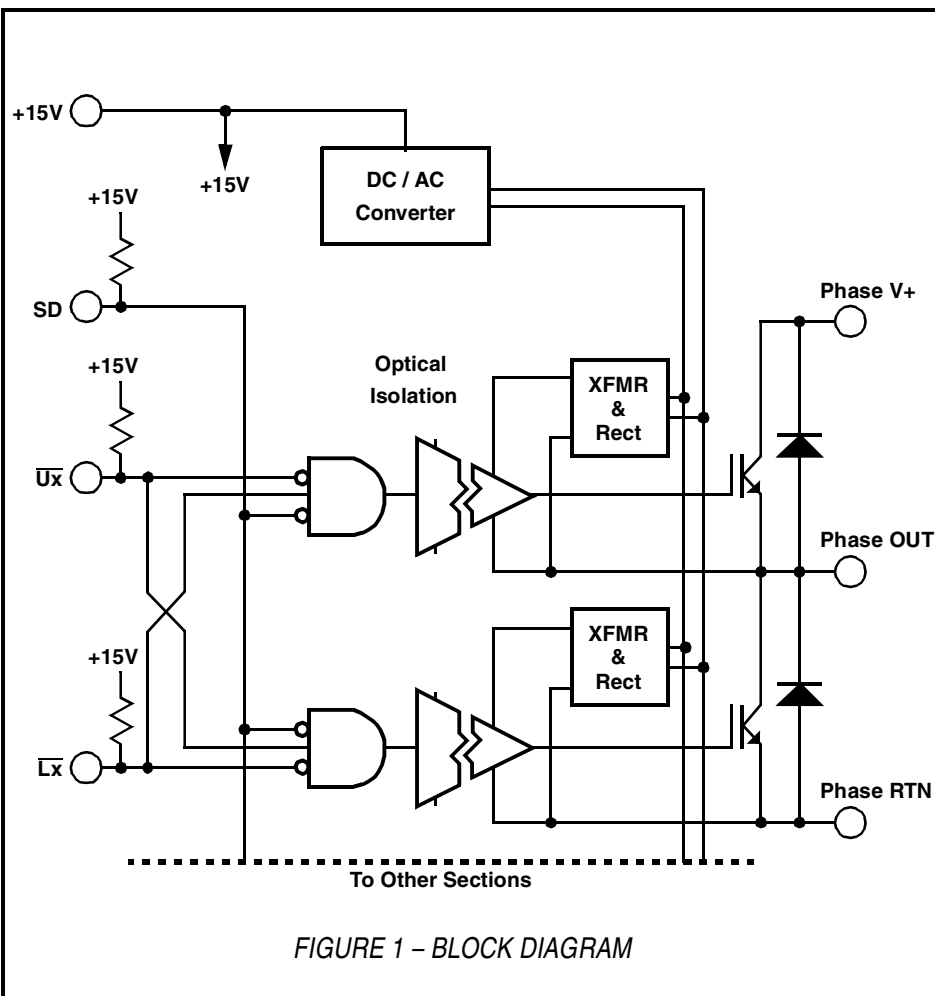

Additional applications include environmental conditioning blowers, radar positioning, solar panel positioning, and cryogenic cooler pumps. The ACT5101-1 is therefore especially suitable for use in applications for all military tank upgrades, helicopters, planes and new commercial avionics using 270 VDC as the main power.

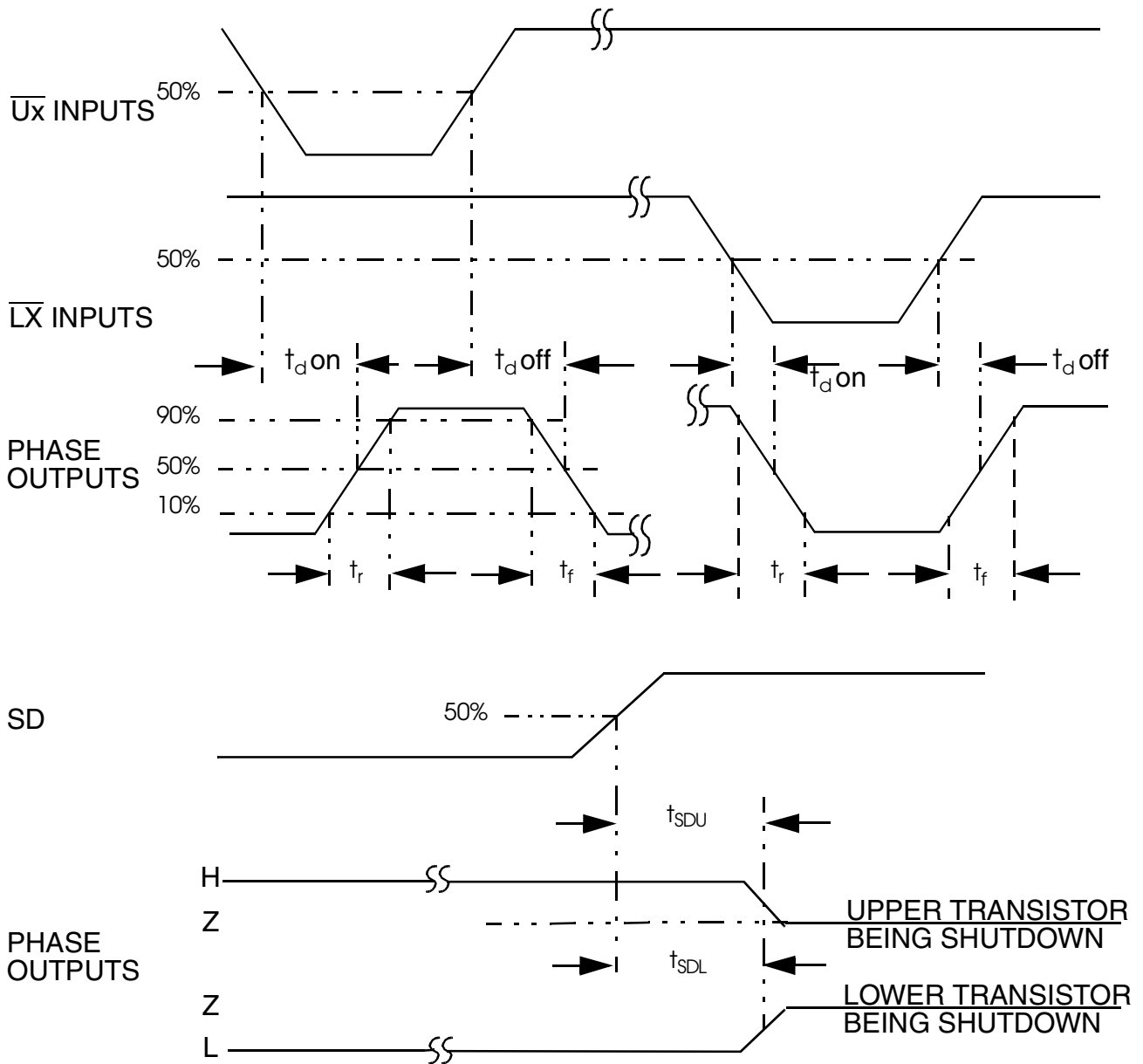

FIGURE 2 - TIMING DIAGRAM

Table I – Absolute Maximums

(T _C = +25°C unless otherwise specified)			
PARAMETER	SYMBOL	RANGE	UNITS
SUPPLY VOLTAGE (PINS 3,7,11)	V+A,V+B,V+C	500	V DC
+15 V SUPPLY (PIN 12)	+15V	18	V DC
OUTPUT CURRENT			
CONTINUOUS	I _o	40	A
PULSED	I _{op}	60	A
CASE OPERATING TEMPERATURE	T _C	-55 to +125	°C
CASE STORAGE TEMPERATURE RANGE	T _{Cs}	-55 to 150	°C
JUNCTION TEMPERATURE	T _J	150	°C

Table II – Normal Operating Conditions

(T _C = +25°C unless otherwise specified)						
PARAMETERS	SYMBOL	TEST CONDITIONS	MIN	TYP	MAX	UNIT
POWER OUTPUT STAGE						
Output Current Continuous	I _o				40	A
Supply Voltage	V+A,V+B,V+C		15	270	500	V DC
Output Voltage Drop (each IGBT)	V _{CE(SAT)}	I _o = 40A			3.4	V DC
Instantaneous Forward Voltage (flyback diode)	V _F	I _{op} = 40A (See Note 1)			2.4	V DC
Reverse Recovery Time (flyback diode)	t _{rr}				35	nsec
Reverse Leakage Current at T _c =25° C	I _r	See Note 2			0.25	mA
Reverse Leakage Current at T _c =125° C	I _r				8	mA
LOGIC INPUT SIGNALS (INTERNALLY PULLED UP) (V+ = 15V)						
Input Voltage Low	V _{INL}				4	V DC
Input Voltage High	V _{INH}		6.8			V DC
Input Current Low	I _{INH}				3.75	mA

Table II – Normal Operating Conditions (Continued)

$(T_C = +25^\circ\text{C}$ unless otherwise specified)

PARAMETERS	SYMBOL	TEST CONDITIONS	MIN	TYP	MAX	UNIT
SWITCHING CHARACTERISTICS						
Upper Drive:						
Turn-on propagation delay	$t_d(\text{on})$				700	nsec
Turn-off propagation delay	$t_d(\text{off})$				2	μsec
Shut-down propagation delay	t_{SDU}				3.5	μsec
Turn-on Transition Time	t_r				100	nsec
Turn-off Transition Time	t_f				250	nsec
Lower Drive:						
Turn-on propagation delay	$t_d(\text{on})$				600	nsec
Turn-off propagation delay	$t_d(\text{off})$				2	μsec
Shut-down propagation delay	t_{SDL}				3.5	μsec
Turn-on Transition Time	t_r				250	nsec
Turn-off Transition Time	t_f				200	nsec
SWITCHING ENERGY LOSSES (At $I = 40\text{A}$, $V = 480\text{V}$)						
Turn-on Energy	E_{on}	$T_C = +125^\circ\text{C}$		4		mJ
Turn-off Energy	E_{off}			6		mJ
DEAD TIME	t_{dt}		500			nsec
THERMAL						
Junction-Case Thermal Resistance (IGBT)	θ_{jCIGBT}	each transistor			.45	$^\circ\text{C}/\text{W}$
Junction-Case Thermal Resistance (DIODE)	θ_{jCDIODE}	each diode			.85	$^\circ\text{C}/\text{W}$
Maximum Lead Soldering Temp	T_S	See Note 3			250	$^\circ\text{C}$
Junction Temperature Range	T_J		-55		150	$^\circ\text{C}$
Case Operating Temperature	T_C		-55		125	$^\circ\text{C}$
Case Storage Temperature	T_{CS}		-55		150	$^\circ\text{C}$

NOTES:

1. Pulse width $\leq 300 \mu\text{sec}$ duty cycle $\leq 2\%$
2. $V_+ = 480 \text{V}$, Inputs = logic "1"
3. Solder 1/8" from case for 5 seconds maximum

FUNCTION	PIN #	DESCRIPTION
V+ A	11	High Voltage D.C. Bus, Phase A
V+ B	7	High Voltage D.C. Bus, Phase B
V+ C	3	High Voltage D.C. Bus, Phase C
+15V	12	+15 VDC input required to power gate drive supply and gate drive circuitry of all three phases.
GND	19,22,26	Reference for LOGIC supply, +15V supply, and digital inputs.
RTN A	8	Return for High Voltage Bus, Phase A.
RTN B	5	Return for High Voltage Bus, Phase B
RTN C	1	Return for High Voltage Bus, Phase C
PHASE A	9	Output to motor winding Phase A
PHASE B	6	Output to motor winding Phase B
PHASE C	2	Output to motor winding Phase C
UA	18	Digital input to Phase A upper transistor
LA	17	Digital input to Phase A lower transistor
UB	21	Digital input to Phase B upper transistor
LB	20	Digital input to Phase B lower transistor
UC	25	Digital input to Phase C upper transistor
LC	24	Digital input to Phase C lower transistor
SD	23	Digital shut-down input to enable / disable all six gate drives
N/C	4,10,13-16	No connection Internally

DIGITAL INPUT STAGE

The ACT5101-1 offers complete flexibility by allowing the user to turn on/off each of the 6 IGBTs in any order or combination desired which enables the hybrid to be commutated in a 6 step trapezoidal mode. The only unacceptable combination would be to turn on an upper and lower transistor of the same phase. This is not a desirable condition for normal operation and is therefore not allowed. The ACT5101-1 has a digital lockout feature that prevents turn-on of two in-line transistors. Damage to one or both of the transistors would occur if this protection circuitry was not present in the hybrid. As a safety precaution, it is still recommended that a 500 nsec dead time be installed between commands at the inputs of the upper and lower transistors of the same phase. This will compensate for any lag in transistor turn-off due to the inductive load.

The SD input allows the user to enable/disable the drive stage of the ACT5101-1 on demand. This input can be incorporated into the user's temperature or current monitoring circuitry to shutdown the hybrid if excessive current or case temperatures are sensed.

The digital input circuits are of the Schmitt trigger type with hysteresis of at least 1.6 volts, thus greatly enhancing the input noise immunity. The inputs are internally pulled up to 15 volts so that an uncommitted input is sensed as "OFF", providing a measure of protection against an accidental input disconnect.

GATE DRIVE

The ACT5101-1 includes a gate drive supply which provides a floating voltage for each upper and lower transistor. This constant voltage allows the motor to be operated at very low duty cycles or driven into a stall without any loss of upper or lower gate drive. This performance could not be obtained with only a conventional boot strap design.

POWER OUTPUT STAGE

IGBTs (insulated gate bipolar transistors) are technically similar to bipolars and MOSFETs. An IGBT is a composite of a transistor with an N-channel MOSFET connected to the base of a PNP transistor. Like the MOSFET, it offers high input impedance and requires low input drive current. IGBT conduction losses are low, as with bipolar technology, and IGBT voltage drops are much lower compared with those of MOSFETs. Consequently, the IGBT offers a high current density. With a smaller die size than the MOSFET, it can handle the same current rating. Unlike MOSFETs, IGBTs have no intrinsic body diode. The ACT5101-1 includes 35 nsec fast recovery rectifiers in parallel across each of the 6 IGBTs to carry the reverse current when the IGBT is turned off.

It is important for the user to observe the Absolute Maximum ratings of the ACT5101-1 so that the voltage and current rating is not exceeded. If over-voltage/over-current protection is desired it must be implemented external to the ACT5101-1. Figure 3 shows the ACT5101-1 output current capability vs. case temperature.

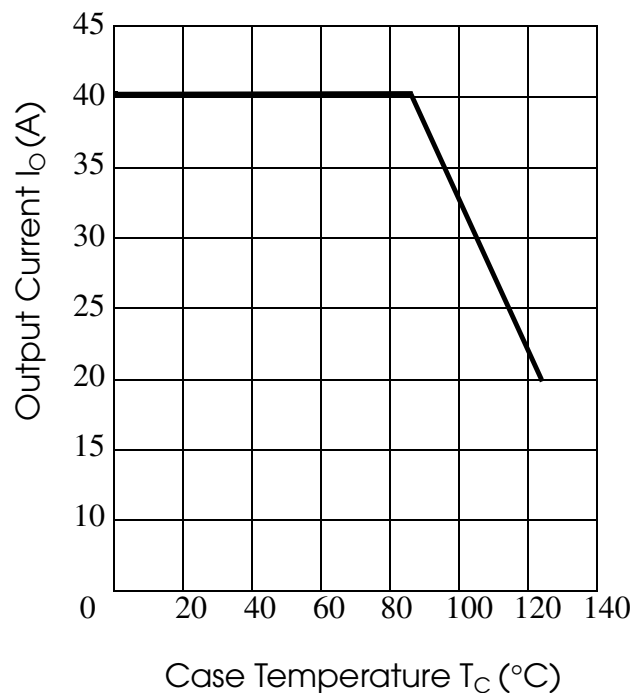

FIGURE 3 - OUTPUT CURRENT VS. CASE TEMPERATURE

POWER DISSIPATION

Power dissipation in the ACT5101-1 is composed of three elements: IGBT conduction losses, IGBT switching losses, and commutation diode conduction losses. It is important that the user calculates power dissipations over the full range of operating conditions of the hybrid, and uses these dissipations to compute the worst case junction temperatures both for the IGBTs and diodes. The 150° C maximum junction temperature shown in Table 2 must not be exceeded. Additionally, program specific derating and reliability constraints may require lower junction temperatures than the 150° C maximum.

Calculating IGBT conduction losses requires the user to determine load profiles for the hybrid both in current and time duration. IGBT collector-emitter voltage drops are shown in Figure 4.

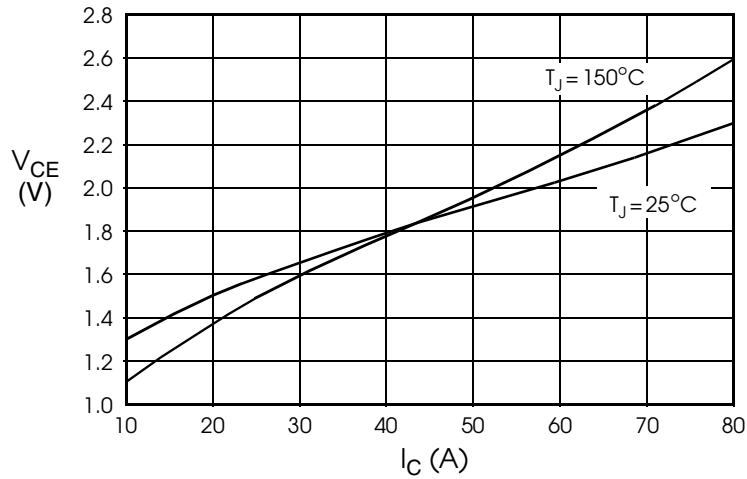

FIGURE 4 - IGBT COLLECTOR-TO-EMITTER VOLTAGE VS. COLLECTOR CURRENT

Based upon this voltage drop and the conduction duty cycle a conduction power loss may be calculated as:

$$P_c = \delta_s \cdot \delta_{PWM} \cdot V_{CE} \cdot I_C$$

where:

- P_c = Conduction IGBT Power Dissipation
- δ_s = Switch Duty Cycle, (.33 for brushless drives in run condition, 1 in stall)
- δ_{PWM} = PWM on/off ratio
- V_{CE} = Collector Emitter voltage from Figure 4 for a particular collector current
- I_C = Collector current

Switching losses are dependent upon the operating frequency, collector current and again duty cycle as:

$$P_s = \delta_s \cdot [E_{on} + E_{off}] \cdot f_o \cdot \frac{I_C}{40}$$

where:

- P_s = Switching IGBT Power Dissipation
- E_{on} = Turn on energy loss from Table 2
- E_{off} = Turn off energy loss from Table 2
- f_o = Pulse width modulation frequency
- I_C = Collector current

Commutation diode losses are calculated as:

$$P_d = \delta_s \cdot [1 - \delta_{PWM}] \cdot V_f \cdot I_f$$

where:

- P_d = Commutation diode losses
- V_f = Commutation diode forward voltage from Figure 5
- I_f = Commutation diode current

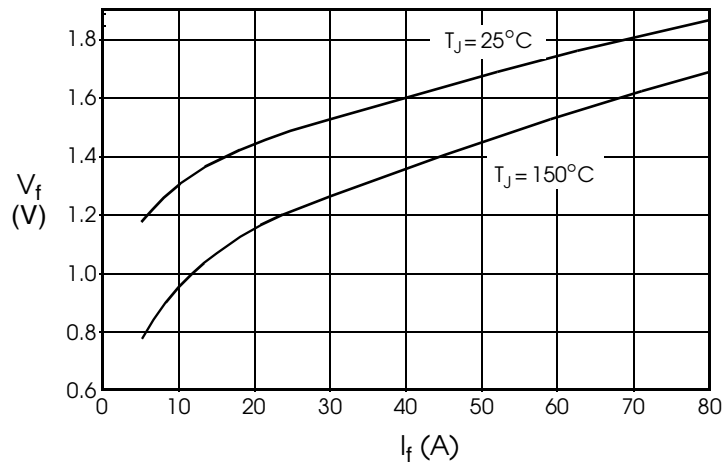

FIGURE 5 - DIODE VOLTAGE DROP VS. FORWARD CURRENT

Once the dissipations are calculated the junction temperatures may then be computed by summing the conduction losses and switching losses for the IGBT and the commutation diode loss and multiplying these dissipations by the respective junction to case thermal resistance as shown below:

$$T_{jIGBT} = [P_c + P_s] \cdot \theta_{jcIGBT} + T_C$$

$$T_{jDIODE} = P_d \cdot \theta_{jcDIODE} + T_C$$

where:

- T_{jIGBT} = IGBT Junction Temperature
- T_{jDIODE} = Commutation Diode Junction Temperature
- θ_{jcIGBT} = IGBT Thermal resistance from Table 2
- $\theta_{jcDIODE}$ = Diode Thermal resistance from Table 2
- T_{case} = Case temperature

It is important that the user calculate junction temperatures over the full range of operating conditions, including maximum load and stall conditions. Typically, hybrid losses peak at just maximum load with duty cycles approaching, but just under, unity. Single transistor and diode losses peak under stall conditions since power is dissipated in just one channel.

EXAMPLE

As a typical application consider a 10 HP brushless DC motor operating off a 270V line in a pump application. The drive is trapezoidal, and the nominal load current will be 30 A. The system current limit is set to roll back the PWM to maintain a maximum load current of 25 amperes in the event of a stall. Maximum case temperature will be 85 C. Duty cycles may approach unity, but at stall it will be approximately 0.1. PWM frequency is 20 kHz.

At a run condition each transistor will be on for 120 degrees; then

$$P_c = \delta_S \cdot \delta_{PWM} \cdot V_{CE} \cdot I_C$$

$$\delta_S = 0.33$$

$$\delta_{PWM} = 1$$

$$V_{CE} = 1.6 \text{ V}$$

$$I_C = 30 \text{ A}$$

$$P_c = 0.33 \cdot 1.6 \cdot 30$$

$$P_c = 15.8 \text{ W}$$

$$P_s = \delta_S \cdot [E_{on} + E_{off}] \cdot f_o \cdot \frac{I_C}{40}$$

$$E_{on} = 0.004 \text{ J}$$

$$E_{off} = 0.006 \text{ J}$$

$$f_o = 20000 \text{ Hz}$$

$$P_s = 0.33 \cdot [0.004 + 0.006] \cdot 20000 \cdot \frac{30}{40}$$

$$P_s = 49.5 \text{ W}$$

$$T_{jIGBT} = [P_c + P_s] \cdot \theta_{jcIGBT} + T_C$$

$$\theta_{jcIGBT} = 0.45^\circ\text{C/W}$$

$$T_C = 85^\circ \text{ C}$$

$$T_{jIGBT} = [15.8 + 49.5] \cdot 0.45^\circ + 85^\circ$$

$$T_{jIGBT} = 114.4^\circ \text{ C}$$

Maximum hybrid dissipation is:

$$P_{HYBRID} = 6[P_s + P_c]$$

$$P_{HYBRID} = 6[49.5 + 15.8]$$

$$P_{HYBRID} = 391.8 \text{ W}$$

At stall only two elements will be on, and they will be on full time.

$$P_c = \delta_S \cdot \delta_{PWM} \cdot V_{CE} \cdot I_C$$

$$\delta_S = 1$$

$$\delta_{PWM} = 0.1$$

$$V_{CE} = 1.6 \text{ V}$$

$$I_C = 25 \text{ A}$$

$$P_c = 1 \cdot 0.1 \cdot 1.6 \cdot 25$$

$$P_c = 4.0 \text{ W}$$

$$P_s = \delta_S \cdot [E_{on} + E_{off}] \cdot f_o \cdot \frac{I_C}{40}$$

$$E_{on} = 0.004 \text{ J}$$

$$E_{off} = 0.006 \text{ J}$$

$$f_o = 20000 \text{ Hz}$$

$$P_s = 1 \cdot [0.004 + 0.006] \cdot 20000 \cdot \frac{25}{40}$$

$$P_s = 125 \text{ W}$$

$$P_d = \delta_S \cdot [1 - \delta_{PWM}] \cdot V_f \cdot I_f$$

$$V_f = 1.3 \text{ V}$$

$$I_F = 25 \text{ A}$$

$$P_d = 1 \cdot [1 - 0.1] \cdot 1.3 \cdot 25$$

$$P_d = 29.25 \text{ W}$$

$$T_{jIGBT} = [P_c + P_s] \cdot \theta_{jcIGBT} + T_C$$

$$\theta_{jcIGBT} = 0.45^\circ \text{C/W}$$

$$T_C = 85^\circ \text{C}$$

$$T_{jIGBT} = [4 + 125] \cdot 0.45^\circ + 85^\circ$$

$$T_{jIGBT} = 143^\circ \text{C}$$

$$T_{j\text{DIODE}} = [P_d] \cdot \theta_{jc\text{DIODE}} + T_C$$

$$\theta_{jc\text{DIODE}} = 0.85^\circ\text{C/W}$$

$$T_C = 85^\circ\text{C}$$

$$T_{j\text{DIODE}} = 29.25 \cdot 0.85^\circ + 85^\circ$$

$$T_{j\text{DIODE}} = 109.9^\circ\text{C}$$

Maximum hybrid dissipation will be:

$$P_{\text{HYBRID}} = 2[P_s + P_c + P_d]$$

$$P_{\text{HYBRID}} = 2[125 + 4 + 29.25]$$

$$P_{\text{HYBRID}} = 316.5\text{ W}$$

MECHANICAL

The ACT5101-1 construction utilizes only the highest quality materials and manufacturing available to ensure a high reliability, robust power hybrid design. The case is selected for best thermal conductivity, hermeticity, and voltage/current carrying capability. The case is electrically isolated from the circuit and can withstand 1500 VAC from pin to case, and input pins to output pins, therefore no insulating pads or washers are required for mounting.

In order to remove the heat being generated from the ACT5101-1, it must be bolted down to the motor, a heat sink or the actual system chassis such as a missile structure or aircraft wing rib for example. Thermally conductive grease or a "Sil-pad" is recommended between the hybrid case baseplate and its mounting surface to fill in any surface imperfections and improve the heat transfer from case-to-heat sink. It is important to keep the temperature at this interface no greater than +125 degrees C in order to maintain safe semi-conductor junction temperatures.

The leads of the ACT5101-1 can be formed upward, away from the baseplate, so that a PC board can be mounted directly above it. A wiring harness can also be hand-wired and soldered directly to the leads of the ACT5101-1 if this is preferred.

AEROFLEX CIRCUIT TECHNOLOGY

Power Package Outline

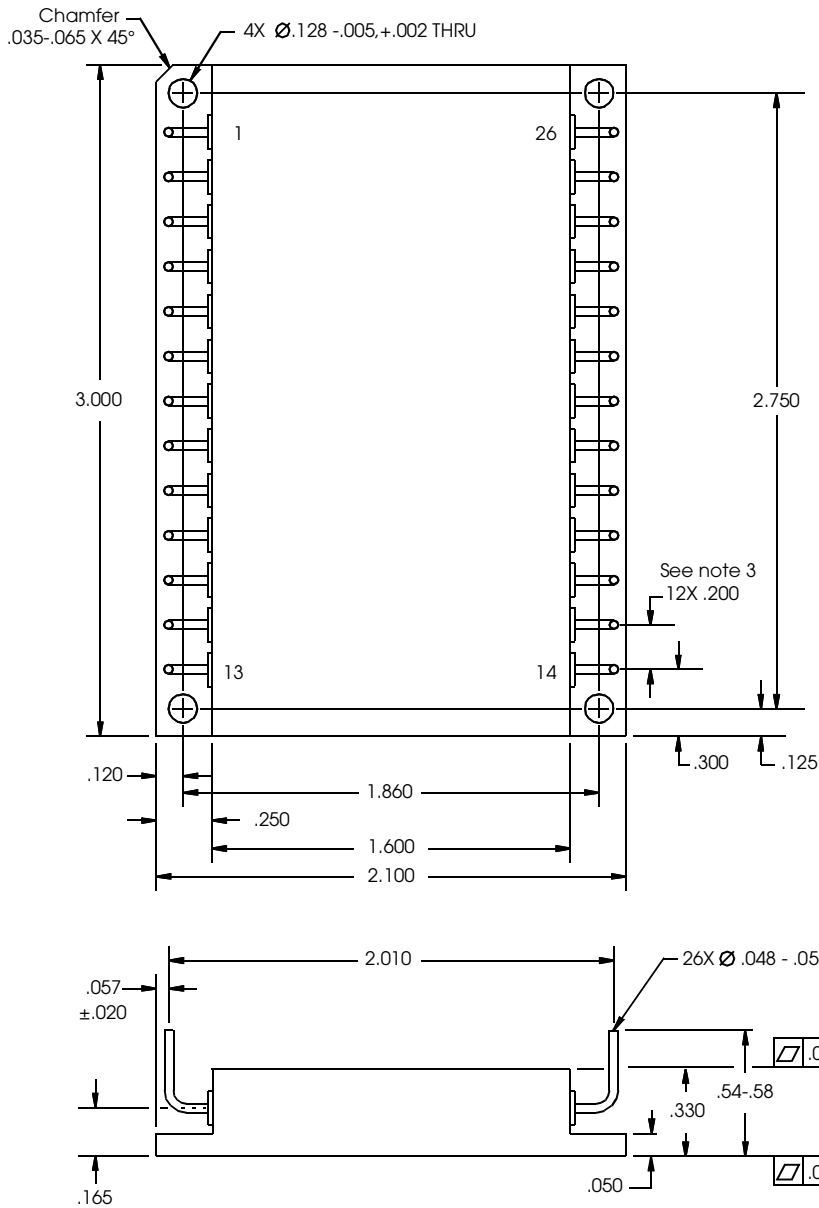

Notes:

1. Package contains BeO substrate.
2. Dimensions Tolerance: \pm .005, unless otherwise noted.
3. Pin Tolerance: non-cumulative

INPUTS							OUTPUTS		
UA	UB	UC	LA	LB	LC	SD	PHASE A	PHASE B	PHASE C
1	1	0	1	0	1	0	Z	L	H
1	1	0	0	1	1	0	L	Z	H
1	1	0	0	0	1	0	L	L	H
1	0	1	1	1	0	0	Z	H	L
1	0	1	0	1	1	0	L	H	Z
1	0	1	0	1	0	0	L	H	L
1	0	0	0	1	1	0	L	H	H
1	0	0	0	1	0	0	L	H	Z
1	0	0	0	0	1	0	L	Z	H
0	1	1	1	1	0	0	H	Z	L
0	1	1	1	0	1	0	H	L	Z
0	1	1	1	0	0	0	H	L	L
0	1	0	1	0	1	0	H	L	H
0	1	0	1	0	0	0	H	L	Z
0	1	0	0	0	1	0	Z	L	H
0	0	1	1	1	0	0	H	H	L
0	0	1	1	0	0	0	H	Z	L
0	0	1	0	1	0	0	Z	H	L
1	1	1	1	1	1	0	Z	Z	Z
1	1	1	0	0	0	0	L	L	L
0	0	0	1	1	1	0	H	H	H
X	X	X	X	X	X	1	Z	Z	Z

H=high level, L=low level, X=irrelevant, Z=high impedance (off)

PIN	FUNCTION	PIN	FUNCTION
1	RTN C	26	GND
2	PHASE C	25	UC
3	V + C	24	LC
4	N/C	23	SD
5	RTN B	22	GND
6	PHASE B	21	UB
7	V + B	20	LB
8	RTN A	19	GND
9	PHASE A	18	UA
10	N/C	17	LA
11	V + A	16	N/C
12	+15 V	15	N/C
13	N/C	14	N/C

The information contained in this data sheet is believed to be accurate; however, Aeroflex Laboratories Incorporated assumes no responsibility for its use, and no license or rights are granted by implication or otherwise in connection therewith.

Specifications subject to change without notice

Aeroflex Circuit Technology
35 South Service Road
Plainview New York 11803

Telephone: (516) 694-6700
FAX: (516) 694-6715
Toll Free Inquiries: 1-(800) 843-1553