

Stamped contacts Crimp female contacts diameter 1,6 mm for wire gauge AWG 26 - 20 silver plated

Part No. TN02 016 0003 1

Series Contacts

Subseries Contact Stamped contacts



COMMON CHARACTERISTICS

Contact diameter		1,6 mm
Insulation diameter		1,0 - 2,0 mm
Wire gauge from		0,14
Wire gauge to		0,5
Wire gauge (AWG) from		26
Wire gauge (AWG) to		20
Packaging / supplied as		Contacts on reel for crimp machines-left hand side
No. of pieces		2.000
Sex of Contact		Socket
Type of contact		Stamped/rolled crimp contact

ELECTRICAL CHARACTERISTICS

Contact resistance	DIN EN 60512-2-1, Test 2a / IEC 60512-2-1, Test 2a	< 5 m
--------------------	--	-------

Stamped contacts Crimp female contacts diameter 1,6 mm for wire gauge AWG 26 - 20 silver plated

Part No. TN02 016 0003 1

Series Contacts

Subseries Contact Stamped contacts

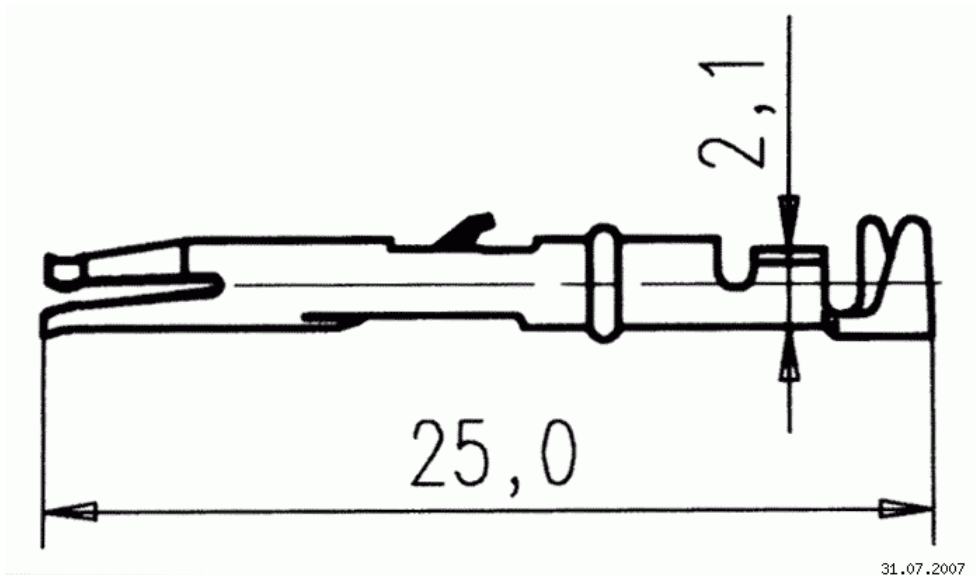

Drawing Dimensions in mm (Inch)

Stamped contacts Crimp female contacts diameter 1,6 mm for wire gauge AWG 26 - 20 silver plated

Part No. TN02 016 0003 1

Series Contacts

Subseries Contact Stamped contacts

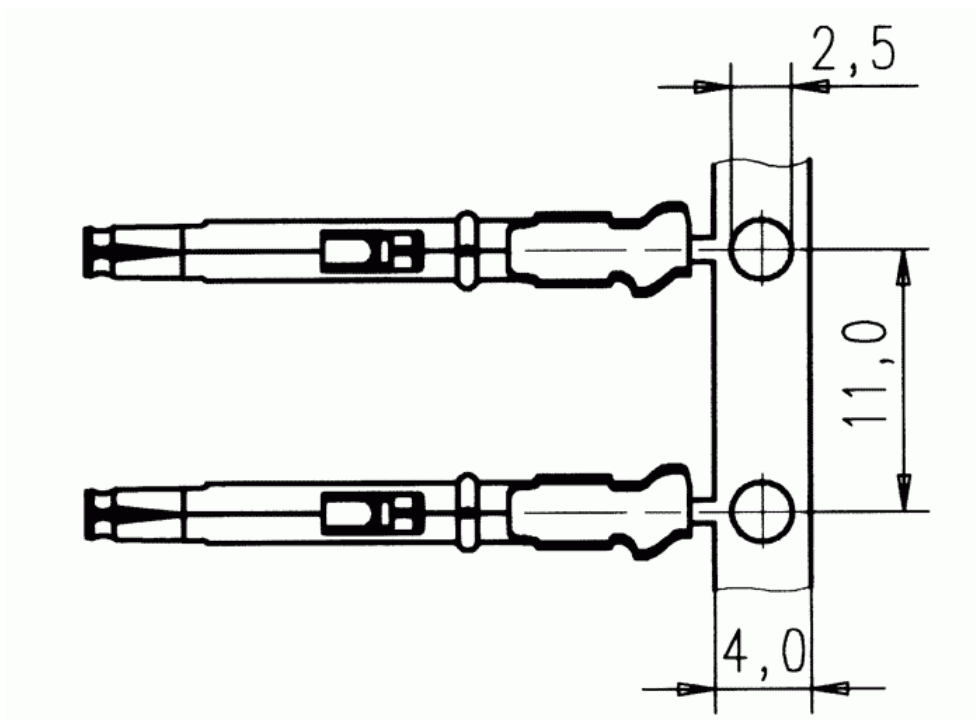

Mouser Electronics

Authorized Distributor

Click to View Pricing, Inventory, Delivery & Lifecycle Information:

[Amphenol:](#)

[TN0201600031](#)