

ISO VIEW

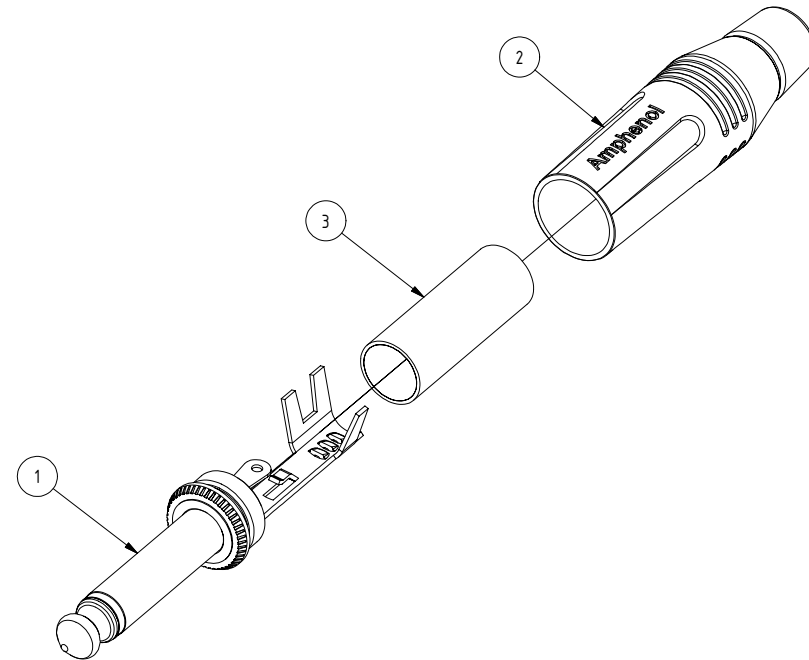

Parts List				
ITEM	PART NUMBER	DWG No	DESCRIPTION	QTY
1	50310007-*30	50310007-130-1	INSERT ASSEMBLY	1
2	53490001-*31	53490001-331-1	BACKSHELL ASSEMBLY	1
3	51270016-521	51270013-521-1	PVC INSULATION TUBE	1

Part Numbers According to Shell and Contact Finish			
CATALOGUE P/No	REFERENCE P/No.	SHELL FINISH	CONTACT FINISH
ACPM-GN	55010218-000	NICKEL	NICKEL SLEEVE AND TIP
ACPM-GN-AU	55010218-001	NICKEL	GOLD SLEEVE AND TIP
ACPM-GB	55010218-002	BLACK	NICKEL SLEEVE AND TIP
ACPM-GB-AU	55010218-003	BLACK	GOLD SLEEVE AND TIP

UNLESS OTHERWISE SPECIFIED TOLERANCE TO BE		THIS DOCUMENT IS THE PROPERTY OF AMPHENOL AUSTRALIA PTY LTD. NO PART THEREOF MAY BE REPRODUCED AND USED WITHOUT THE PRIOR WRITTEN CONSENT OF THE OWNER				1	UPDATE TO MODIFIED COMPONENTS	LV	1/03/2004	8241
LINEAR		ANGULAR		CAD FILE: 55010218000111	DSD: T.N	DATE: 7/12/2002	0	FIRST ISSUE	T.N	7/12/2002
X ± 0.5	X ₁ ± 1			MATERIAL: REFER TO COMPONENTS		DATE: 04-05-04	CHANGE DETAILS			
XX ± 0.1	XX ₁ ± 30'			FINISH: SEE TABLE		DATE: 04-05-04	BY DATE			
XXX ± 0.05	XXX ₁ ± 15'			APP'D: P.M		DATE: 04-05-04	CHG/No			
BREAK ALL SHARP EDGES AND REMOVE ALL BURRS		DO NOT SCALE		DIMENSIONS IN MILLIMETRES		SCALE: 2:1 UOS	PART No: SEE TABLE		SIZE: A3	TITLE: 1/4" PHONE PLUG MONO ASSY
				THIRD ANGLE PROJECTION			DRAWING NO. 55010218-000-1		SHEET 1/1	

Amphenol

Amphenol Australia Pty Ltd, 2 Fineways Blvd, Keysborough, Vic3173

Mouser Electronics

Authorized Distributor

Click to View Pricing, Inventory, Delivery & Lifecycle Information:

[Amphenol:](#)

[ACPM-GN](#) [ACPM-GN-AU](#) [ACPM-GB](#) [ACPM-GB-AU](#)