

Four Channel Supervisory IC

The ISL6536 is a four channel supervisory IC designed to monitor voltages $>, = 0.7V$. This IC bias range is from 2.7V to 4V but can supervise any positive voltage using an external resistor divider to translate to a lower voltage for comparison to the internal 0.63V reference.

Once properly biased and enabled when all four voltage monitor (VMON) inputs are satisfied the PGOOD output will be immediately released to go high to signal that voltage is valid on all four rails. Subsequently when the monitored voltage on any rail drops below its user defined threshold point, the PGOOD output is pulled low. Each rail's VMON point is independently adjustable with a resistor divider. The PGOOD output is guaranteed to be valid with IC bias lower than 1V. The VMON inputs will ignore 30 μ s transients on the monitored supplies. The PGOOD output is an open-drain to allow ORing of multiple signals and interfacing to a range of logic levels. The ENABLE input provides for a reset of the PGOOD output when it is pulled down below 0.5V. With an internal 10 μ A pull-up to VDD it can be signalled with common logic or pulled to ground with a push button switch.

Typical Application Schematic

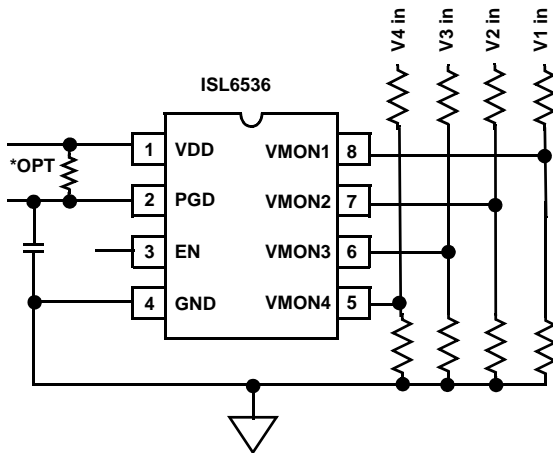

Features

- Adjustable undervoltage lockout for each supply
- Active high PGOOD Output
- Guaranteed PGOOD Valid to Falling VDD $< 1V$
- VMON Glitch Immunity
- Pb-Free Available (RoHS Compliant)

Applications

- Graphics Cards
- Multi voltage DSPs and Processors
- μ P Voltage Monitoring
- Embedded Control Systems
- Intelligent Instruments
- Medical Equipment
- Network Routers
- Portable Battery-Powered Equipment
- Set-Top Boxes
- Telecommunications Systems

Ordering Information

PART NUMBER	TEMP. RANGE (°C)	PACKAGE	PKG. DWG. #
ISL6536IB	-40 to +85	8 LD SOIC	M8.15
ISL6536IBZ (See Note)	-40 to +85	8 LD SOIC (Pb-free)	M8.15
ISL6536IB-T	8 LD SOIC Tape and Reel		
ISL6536IBZ-T (See Note)	8 LD SOIC (Pb-free)		

NOTE: Intersil Pb-free products employ special Pb-free material sets; molding compounds/die attach materials and 100% matte tin plate termination finish, which are RoHS compliant and compatible with both SnPb and Pb-free soldering operations. Intersil Pb-free products are MSL classified at Pb-free peak reflow temperatures that meet or exceed the Pb-free requirements of IPC/JEDEC J STD-020.

Pin Descriptions

ISL6536	PIN NAME	FUNCTION DESCRIPTION
1	VDD	Bias IC from nominal 2.7V to 4V
2	PGOOD	PGOOD is the boolean AND function of all the UV inputs being satisfied. This is an open drain output and can be pulled high to the appropriate level with an external resistor. Additionally a 20kΩ pull up to VDD is provided internally.
3	ENABLE	Enabling input for supervisory function. Has a 10μA pull-up to VDD
4	GND	IC ground
5-8	VMON1 VMON2 VMON3 VMON4	These inputs provide for a programmable monitored voltage threshold referenced to an internal 0.63V reference. These inputs have a 30μs glitch filter to prevent transient upsets from being recognized by PGOOD.

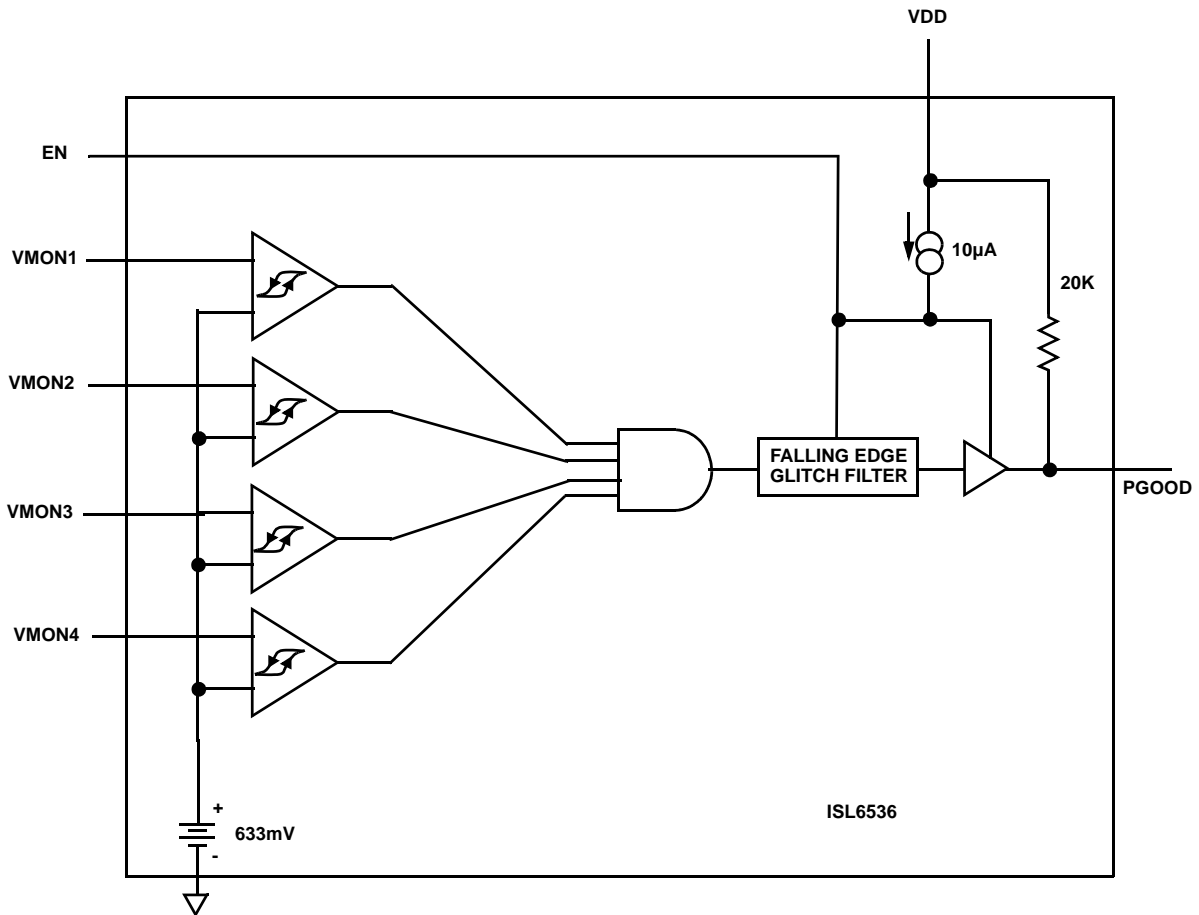

Absolute Maximum Ratings

VDD +5.5V
 VMON, PGOOD, ENABLE -0.3V to VDD+0.3V
 ESD Classification 4kV (HBM)

Operating Conditions

VDD Supply Voltage Range +2.7V to +4V
 Temperature Range (T_A) -40°C to 85°C

Thermal Information

Thermal Resistance (Typical, Note 1) θ_{JA} (°C/W)
 8 LD SOIC 108
 Maximum Junction Temperature 150°C
 Maximum Storage Temperature Range -65°C to 150°C
 Maximum Lead Temperature (Soldering 10s) 300°C

CAUTION: Stresses above those listed in "Absolute Maximum Ratings" may cause permanent damage to the device. This is a stress only rating and operation of the device at these or any other conditions above those indicated in the operational sections of this specification is not implied.

NOTES:

1. θ_{JA} is measured in free air with the component mounted on a high effective thermal conductivity test board. See Tech Brief TB379 for details.
2. All voltages are relative to GND, unless otherwise specified.

Electrical Specifications Nominal VDD = 3.3V, T_A = T_J = -40°C - 85°C, Unless Otherwise Specified

PARAMETER	SYMBOL	TEST CONDITIONS	MIN	TYP	MAX	UNIT
BIAS						
IC Supply Current	I _{VDD}	VMON > VMON_L2H		165	1000	µA
VDD Power On	VDD_L2H	VDD low to high		2.6		V
VDD Power On Reset	VDD_POR	VDD high to low		2.4		V
PGOOD						
Pull-Down Current	p _{GPd}	VPGOOD = 0.5V		2		mA
Pull-Up Resistance	p _{GPu}			20		kΩ
Output Low	V _{PGI}	VDD= 1V		0.05	0.1	V
Delay from VMON Rising	T _{PGdelVMON}	Last valid input = V _{th} to PG release		2		µs
Delay from EN Rising	T _{PGdelENR}	EN high to PG release		0.05		µs
Delay from EN Falling	T _{PGdelENF}	EN low to PG pulling low		0.015		µs
ENABLE						
Rising Threshold	V _{EN}	ENABLE Low to High Threshold	0.4VDD	0.5VDD	0.6VDD	V
Threshold Hysteresis	V _{EN_HYS}			0.065		V
Pull-up Current	I _{ENpu}	VEN = 0.5V		10		µA
VMON Input						
Falling Threshold	3.3VMON_H2L	T _j =+25c	0.623	0.633	0.643	V
Falling Threshold Temp Coeff.	3.3VMON_TC			100		uV/°C
Hysteresis	VVMON_HYS		-	10	-	mV
Range	VMON_RNG		-	8	-	mV
Glitch Filter Duration	TFIL	VMON glitch to PGOOD low Filter	-	30	-	µs

ISL6536 Description and Operation

The ISL6536 is a four channel supervisory IC designed to monitor multiple voltages greater than 0.7V. This IC is suitable for both microprocessors or industrial system applications.

Upon VDD bias power up the PGOOD output is held low with VDD as low as 0V. Once biased to 2.6V and enabled the IC continuously monitors from one to four voltages independently through external resistor dividers comparing each VMON pin voltage to an internal 0.63V reference.

Once all VMON input voltages rise above 0.63V the PGOOD (power good) output signal is released and is pulled high via an external pull resistor to indicate that the power conditions

have been met. The PGOOD output is an open-drain to allow ORing of the signals and interfacing to a wide range of logic levels.

Once any VMON input falls below 0.63V the PGOOD output is pulled low, the VMON inputs are designed to reject fast transients (30µs).

If less than four voltages are being monitored, connect the unused VMON pins to VDD.

The PGOOD pin has an internal 20kΩ pull-up to VDD making an external pull-up resistor unnecessary.

Figure 1 illustrates the operational timing diagram.

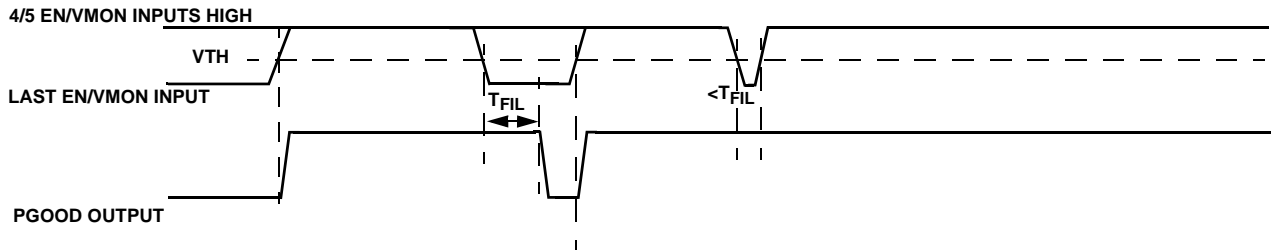

FIGURE 1. ISL6536 OPERATIONAL TIMING DIAGRAM

Typical Performance Curves

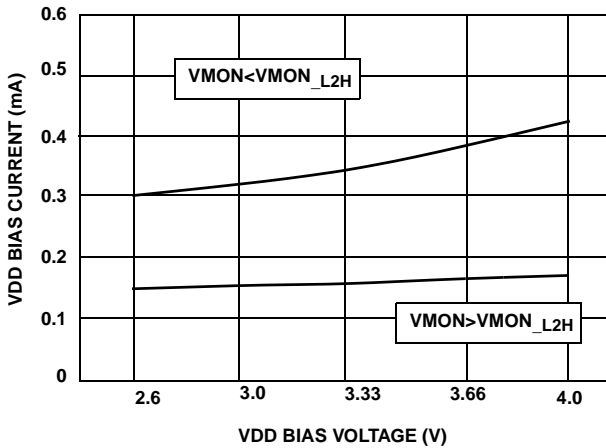

FIGURE 2. VDD CURRENT vs. VDD VOLTAGE

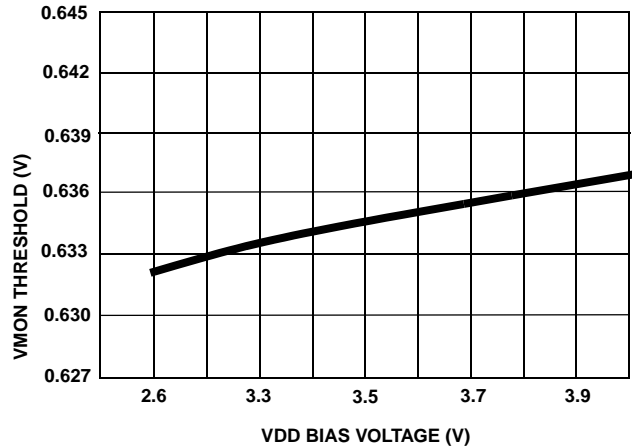
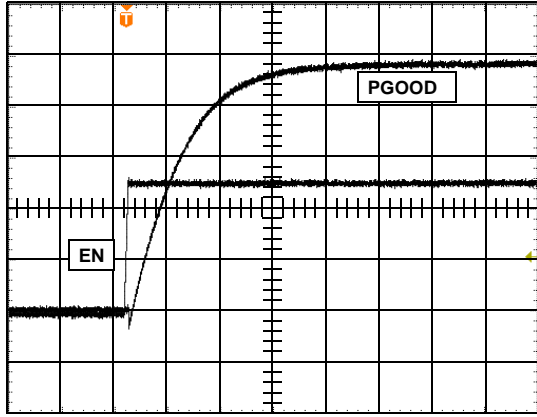

FIGURE 3. VMON THRESHOLD vs. VDD VOLTAGE

Typical Performance Curves (Continued)



PG = 1V/DIV
 EN = 1V/DIV
 1µs/DIV

FIGURE 4. EN HIGH to PGGOOD

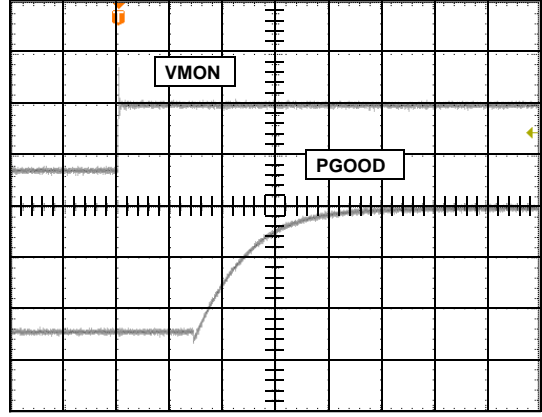

PG = 2V/DIV
 VMON = 1V/DIV
 1µs/DIV

FIGURE 5. VMON HIGH to PGGOOD

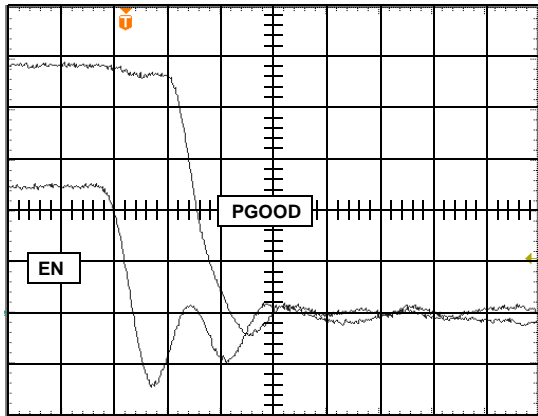

EN = 1V/DIV
 PG = 1V/DIV
 10nS/DIV

FIGURE 6. EN LOW to PGGOOD

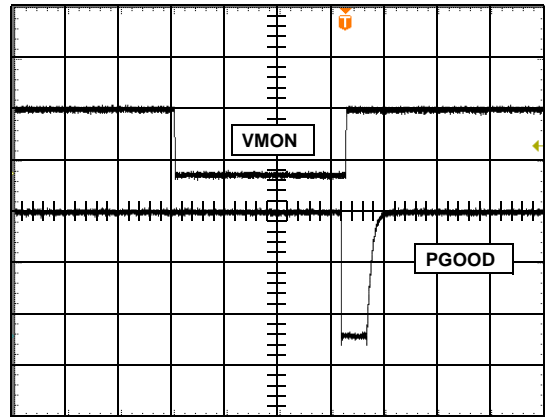

PGOOD = 2V/DIV
 VMON = 1V/DIV
 10µs/DIV

FIGURE 7. VMON LOW to PGGOOD

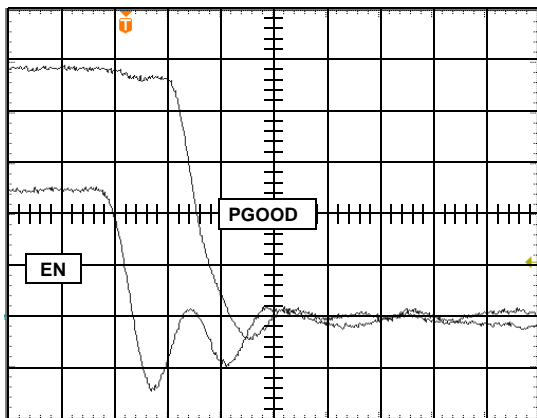

EN = 1V/DIV
 PG = 1V/DIV
 10nS/DIV

FIGURE 8. EN LOW to PGGOOD

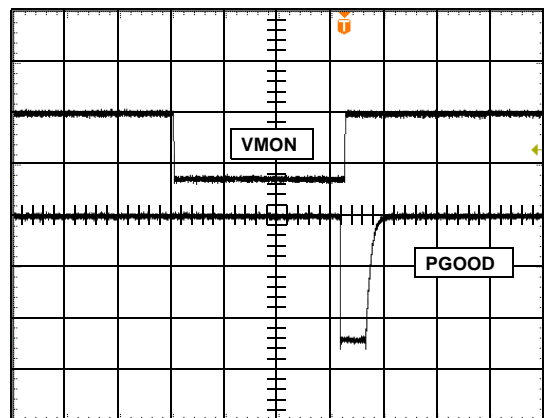

PGOOD = 2V/DIV
 VMON = 1V/DIV
 10µs/DIV

FIGURE 9. VMON LOW to PGGOOD

Small Outline Plastic Packages (SOIC)

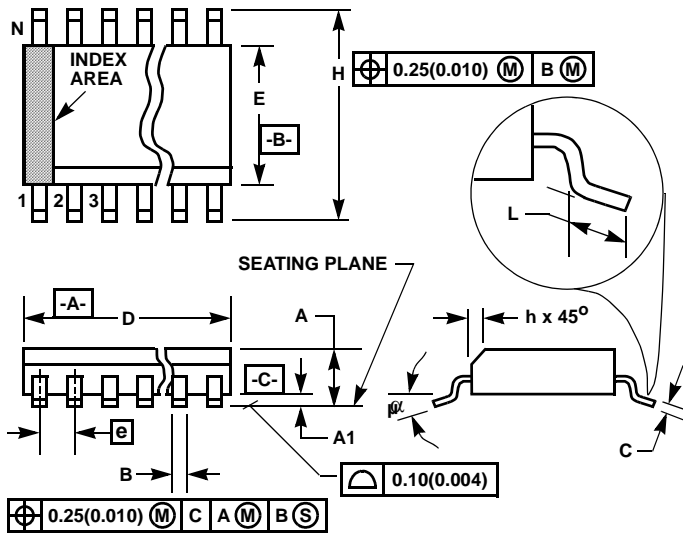

NOTES:

- Symbols are defined in the "MO Series Symbol List" in Section 2.2 of Publication Number 95.
- Dimensioning and tolerancing per ANSI Y14.5M-1982.
- Dimension "D" does not include mold flash, protrusions or gate burrs. Mold flash, protrusion and gate burrs shall not exceed 0.15mm (0.006 inch) per side.
- Dimension "E" does not include interlead flash or protrusions. Interlead flash and protrusions shall not exceed 0.25mm (0.010 inch) per side.
- The chamfer on the body is optional. If it is not present, a visual index feature must be located within the crosshatched area.
- "L" is the length of terminal for soldering to a substrate.
- "N" is the number of terminal positions.
- Terminal numbers are shown for reference only.
- The lead width "B", as measured 0.36mm (0.014 inch) or greater above the seating plane, shall not exceed a maximum value of 0.61mm (0.024 inch).
- Controlling dimension: MILLIMETER. Converted inch dimensions are not necessarily exact.

M8.15 (JEDEC MS-012-AA ISSUE C) 8 LEAD NARROW BODY SMALL OUTLINE PLASTIC PACKAGE

SYMBOL	INCHES		MILLIMETERS		NOTES
	MIN	MAX	MIN	MAX	
A	0.0532	0.0688	1.35	1.75	-
A1	0.0040	0.0098	0.10	0.25	-
B	0.013	0.020	0.33	0.51	9
C	0.0075	0.0098	0.19	0.25	-
D	0.1890	0.1968	4.80	5.00	3
E	0.1497	0.1574	3.80	4.00	4
e	0.050 BSC		1.27 BSC		-
H	0.2284	0.2440	5.80	6.20	-
h	0.0099	0.0196	0.25	0.50	5
L	0.016	0.050	0.40	1.27	6
N	8		8		7
α	0°	8°	0°	8°	-

Rev. 0 12/93

All Intersil U.S. products are manufactured, assembled and tested utilizing ISO9000 quality systems.
Intersil Corporation's quality certifications can be viewed at www.intersil.com/design/quality

Intersil products are sold by description only. Intersil Corporation reserves the right to make changes in circuit design, software and/or specifications at any time without notice. Accordingly, the reader is cautioned to verify that data sheets are current before placing orders. Information furnished by Intersil is believed to be accurate and reliable. However, no responsibility is assumed by Intersil or its subsidiaries for its use; nor for any infringements of patents or other rights of third parties which may result from its use. No license is granted by implication or otherwise under any patent or patent rights of Intersil or its subsidiaries.

For information regarding Intersil Corporation and its products, see www.intersil.com