

## CR THICK FILM CHIP RESISTOR SERIES

### INTRODUCTION

The most popular type of chip resistor developed for surface mount technology. Ideal for general purpose applications. Unique construction and special termination techniques ensure high quality and reliability. Extremely compact size for miniaturization.

### FEATURES

- Excellent Long Term stability
- Available in Bulk and Tape & Reel packing.
- Available in Tolerances of  $\pm 5\%$  &  $\pm 1\%$
- Uniform body size ensures compatibility with High Speed automatic handling machines
- Compatible with flow and re-flow soldering methods

### SPECIFICATIONS

**Resistance Range:** 1 Ohm to 10 M Ohms for E24 values(5%)  
1 Ohm to 1 M Ohms for E96 values(1%)

**Rated Power:** 1/16 to 1W at 70°C (Please see Power Derating Curve)

**Rated Voltage:**  $\checkmark$  Rated Power x Nominal Resistance.

**Overload Voltage:** Please refer to Power Ratings Table.

**Temperature Coefficient:**  $\pm 100$  ppm or  $\pm 200$  ppm per °C.

**Temperature Range:** -55°C to +125°C with derating above 70°C

**Tolerance:**  $\pm 5\%$  or  $\pm 1\%$  (Special tolerance upon request.).

#### Load Life:

The component will be subjected to 1000 hours of testing at rated voltage and 70°C, with duty cycles of 1.5 hours "on" and 0.5 hours "off". After the test the Resistance change will remain within  $\pm 3\%$  of the initial value + 0.1 Ohm for values above 1 M Ohm and 5% for values less than 1 M Ohm.

#### Resistance to Soldering Heat:

The component can be subjected to a soldering temperature of 270 °C for 10 seconds. After the test the Resistance change will remain within  $\pm 3\% + 0.1$  Ohms.

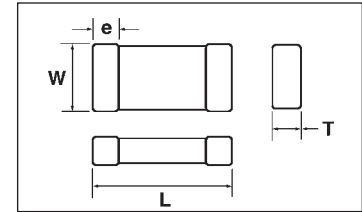

Case Dimensions Table

Dimensions in mm				
Case Code	L	W	T Max	e
0402	1.0 $\pm$ 0.05	0.5 $\pm$ 0.05	0.35 $\pm$ 0.05	0.25 $\pm$ 0.15
0603	1.6 $\pm$ 0.1	0.8 $\pm$ 0.15	0.45 $\pm$ 0.10	0.30 $\pm$ 0.1
0805	2.0 $\pm$ 0.1	1.25 $\pm$ 0.10	0.55 $\pm$ 0.10	0.40 $\pm$ 0.2
1206	3.2 $\pm$ 0.15	1.6 $\pm$ 0.15	0.55 $\pm$ 0.10	0.50 $\pm$ 0.25
2010	5.0 $\pm$ 0.15	2.5 $\pm$ 0.15	0.55 $\pm$ 0.15	0.60 $\pm$ 0.2
2512	6.4 $\pm$ 0.15	3.2 $\pm$ 0.15	0.55 $\pm$ 0.15	0.60 $\pm$ 0.2

#### Power Derating Curve

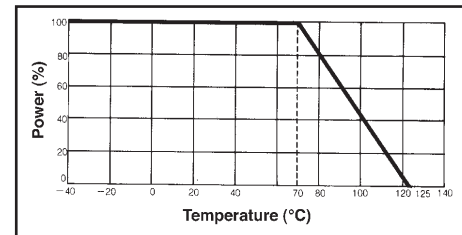

### Tape, Reel and Packing Specifications

#### Reel Dimensions;

##### Reel Dimensions in Millimeters

A	B	C	D	E	W	t
$\phi 178 \pm 2.0$	$\phi 50$ min.	13.0 $\pm 0.5$	21.0 $\pm 0.8$	2.0 $\pm 0.8$	8.8/12.8 $\pm 1.5$	2.0 $\pm 0.5$
$\phi 330 \pm 2.0$	$\phi 100$ min.	13.0 $\pm 0.5$	21.0 $\pm 0.8$	2.0 $\pm 0.8$	8.8/12.8 $\pm 1.5$	2.0 $\pm 0.6$

##### Reel Dimensions in Inches

A	B	C	D	E	W	t
$\phi 7 \pm 0.08$	$\phi 2.0$ min.	5.0 $\pm 0.02$	0.83 $\pm 0.03$	0.08 $\pm 0.3$	0.35/0.50 $\pm 0.06$	0.08 $\pm 0.02$
$\phi 13 \pm 0.08$	$\phi 4.0$ min.	5.0 $\pm 0.3$	0.83 $\pm 0.03$	0.08 $\pm 0.3$	0.35/0.50 $\pm 0.06$	0.08 $\pm 0.02$

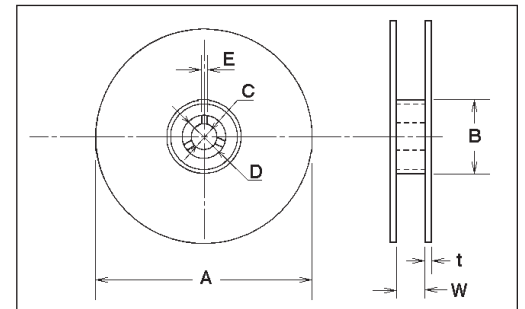

#### Power Ratings Table (Values above 10 M Ohms are available upon request)

SIZE	Rate Power at 70C	Rate Current of Jumper A	Maximum Working Voltage Vw	Maximum Overload Voltage Vo	Temperature Coefficient of Resistance ppm/C	Combination of Resistance Range of Tolerance		Operating Temperature Range C
						F (+1%) (E96)	J (+5%) (E24)	
0402	1/16		50	100	+ 100	10 Ohms-562 K Ohms	10 Ohms - 1 M Ohms	
					$\pm 200$	1 Ohm-9.76 Ohms		
0603	1/10	1	50	100	+ 100	10 Ohms-1 M Ohms	1 Ohm- 10 M Ohms	
					$\pm 200$	1 Ohm - 9.76 Ohms		
0805	1/8		150	300	+ 100	10 Ohms - 1 M Ohms	1 Ohm - 10 M Ohms	
					$\pm 200$	1 Ohm - 9.76 Ohms		
1206	1/4				+ 100	10 Ohms-1 M Ohms	1 Ohm - 10 M Ohms	-55 - + 125
					$\pm 200$	1 Ohm - 9.76 Ohms		
2010	3/4	2			+ 100	10 Ohms - 1 M Ohms	1 Ohm - 10 M Ohms	
					$\pm 200$	1 Ohm - 9.76 Ohms		
2512	1		200	400	+ 100	10 Ohms - 1 M Ohms	1 Ohm - 10 M Ohms	
					$\pm 200$	1 Ohm - 9.76 Ohms		

### Carrier Tape Dimensions;

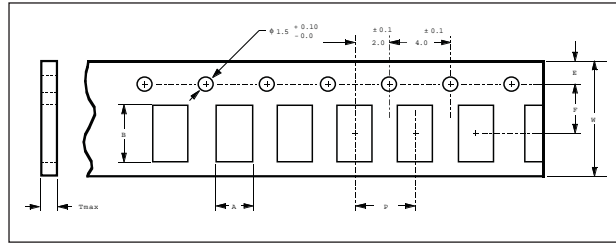

SIZE CODE	A	B	W	F	E	P	Tmax
0402	0.65 (0.026")	1.15 (0.045")	8.0mm (0.315")	3.5mm (0.138")	1.75mm (0.069")	2mm (0.079")	0.43mm (0.018")
0603	1.1 (0.043")	1.9mm (0.075")	8.0mm (0.315")	3.5mm (0.138")	1.75mm (0.069")	4mm (0.157")	0.60mm (0.024")
0805	1.65 (0.065")	2.4mm (0.094")	8.0mm (0.315")	3.5mm (0.138")	1.75mm (0.069")	4mm (0.157")	0.75mm (0.030")
1206	1.9 (0.075")	3.5mm (0.138")	8.0mm (0.315")	3.5mm (0.138")	1.75mm (0.069")	4mm (0.157")	0.75mm (0.030")
2010	2.8 (0.011")	5.6mm (0.22")	12.0mm (0.472")	5.5mm (0.217")	1.75mm (0.069")	4mm (0.157")	0.20mm (0.080")
2512	3.6 (0.142")	6.7mm (0.264")	12.0mm (0.472")	5.5mm (0.217")	1.75mm (0.069")	8mm (0.315")	0.20mm (0.080")

### Packing Methods;

Style	PACKING				
	Paper Taping Reel (R)			Embossed Taping Reel (K)	Bulk Cassette (K)
	7" (178mm)	10" (254mm)	13" (330mm)	7" (178mm)	
CR02 (0402)	10,000	10,000	10,000	-	50,000
CR03 (0603)	5,000	5,000	5,000	-	25,000
CR05 (0805)	5,000	5,000	5,000	-	10,000
CR06 (1206)	5,000	5,000	5,000	-	5,000
CR20 (2010)	-	-	-	4,000	-
CR25 (2512)	-	-	-	4,000	-

### PART NUMBERING

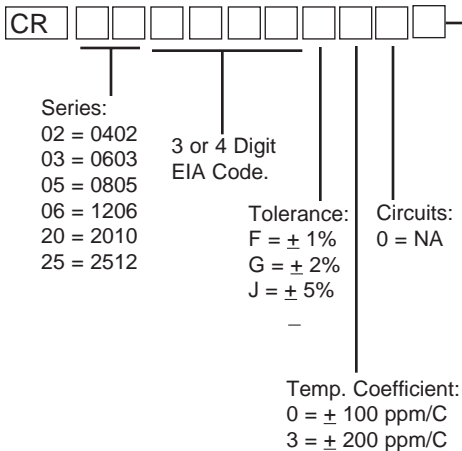

### EIA Code-E24 Values

10	33
11	36
12	39
13	43
15	47
16	51
18	56
20	62
22	68
24	75
27	82
30	91

### Add 3 digit multiplier

Examples:

101= 100 Ohms

472= 4.7K Ohms

684= 680K Ohms

1R0= 1 Ohm

15R= 15 Ohms

Note:

R= decimal point in the EIA code

### EIA Code-E96 Values

10.0	14.7	21.5	31.6	46.4	68.1
10.2	15.0	22.1	32.4	47.5	69.8
10.5	15.4	22.6	33.2	48.7	71.5
10.7	15.8	23.2	34.0	49.9	73.2
11.0	16.2	23.7	34.8	51.1	75.0
11.3	16.5	24.3	35.7	52.3	76.8
11.5	16.9	24.9	36.5	53.6	78.7
11.8	17.4	25.5	37.4	54.9	80.6
12.1	17.8	26.1	38.3	56.2	82.5
12.4	18.2	26.7	39.2	57.6	84.5
12.7	18.7	27.4	40.2	59.0	86.6
13.0	19.1	28.0	41.2	60.4	88.7
13.3	19.6	28.7	42.2	61.9	90.9
13.7	20.0	29.4	43.2	63.4	93.1
14.0	20.5	30.1	44.2	64.9	95.3
14.3	21.0	30.9	45.3	66.5	97.6

### Add 4 digit multiplier

Examples:

1130= 113 Ohms

1871= 1.87K Ohms

6193= 619K Ohms

19R1= 19.1 Ohms

1R21= 1.21 Ohms