

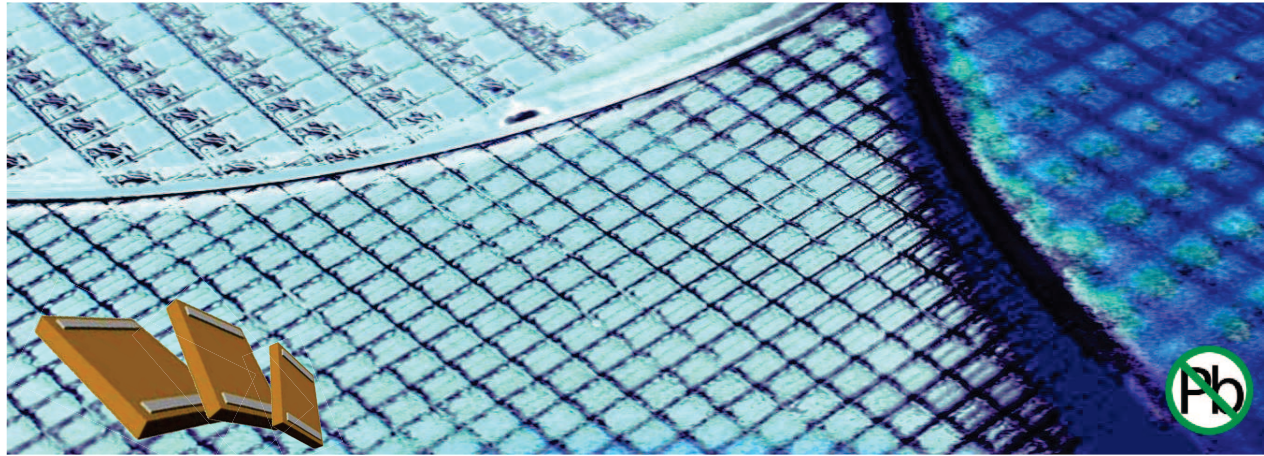

HTSC426.xxx - 0805 High Temperature Silicon Capacitor

Rev 3.0



Key features

- High stability up to 200°C:
 - ◆ Temperature $<\pm 1\%$ (-55 °C to +200 °C)
 - ◆ Voltage $<0.1\%$ /V
 - ◆ Negligible capacitance loss through aging
- Unique high capacitance in EIA/0805 package size, up to 100 nF
- High reliability (FIT <0.017 parts / billion hours)
- Low leakage current down to 100 pA
- Low ESL and Low ESR
- Suitable for lead free reflow-soldering *Please refer to our assembly Application Note for further recommendations

Thanks to the unique IPDiA Silicon capacitor technology, most of the problems encountered in demanding applications can be solved.

High Temperature Silicon Capacitors are dedicated to applications where **reliability** up to **200°C** is the main parameter.

This technology features a capacitor integration capability (up to 250nF/mm²) which offers capacitance value similar to X7R dielectric, but with better electrical performances than C0G/NP0 dielectrics, up to **200°C**.

HTSC provide the highest capacitor **stability** over the full -55°C/+200°C temperature range in the market with a **Temperature coefficient Lower than $\pm 1\%$** .

Key applications

- All applications up to 200°C, such as military, aerospace and automotive industries
- High reliability applications
- Replacement of X7R and C0G dielectrics
- Decoupling / Filtering / Charge pump (i.e.: motor management, temperature sensors)
- Downsizing

The IPDiA technology offers industry leading performances relative to **Failure rate** with a FIT <0.017 .

This technology also offers **high reliability**, up to 10 times better than alternative capacitor technologies, such as Tantalum or MLCC, and eliminates cracking phenomena.

This Silicon based technology is RoHS compliant and compatible with lead free reflow soldering process.

Electrical specification

		Capacitance value					
		10	15	22	33	47	68
Unit	10 pF	Contact IPDIA Sales	Contact IPDIA Sales	Contact IPDIA Sales	Contact IPDIA Sales	Contact IPDIA Sales	Contact IPDIA Sales
	0.1 nF	Contact IPDIA Sales	Contact IPDIA Sales	Contact IPDIA Sales	Contact IPDIA Sales	Contact IPDIA Sales	Contact IPDIA Sales
	1 nF	10 nF: 935.132.426.510	Contact IPDIA Sales	Contact IPDIA Sales	Contact IPDIA Sales	Contact IPDIA Sales	Contact IPDIA Sales
	10 nF	100 nF: 935.132.426.610					

Parameters	Value
Capacitance range	10nF to 100 nF ^(**)
Capacitance tolerances	±15 % ^(***)
Operating temperature range	-55 °C to 200 °C ^(**)
Storage temperatures	-70 °C to 215 °C
Temperature coefficient	<±1 %, from -55 °C to +200 °C
Breakdown voltage (BV)	11 VDC ^(***)
Capacitance variation versus RVDC	0.1 % /V (from 0 V to RVDC)
Equivalent Serial Inductor (ESL)	Max 250 pH
Equivalent Serial Resistor (ESR)	Max 400mΩ ^(***)
Insulation resistance	50GΩ min @ 3V,25°C 20GΩ min @ 3V,200°C
Ageing	Negligible, < 0.001 % / 1000 h
Reliability	FIT<0.017 parts / billion hours,
Capacitor height	Max 400 μm ^(*)

(*) Thinner thickness (as low as 100 μm thick) available, see Low Profile Silicon Capacitor product: LPSC
 (**) Extended temperature range (up to +250 °C) available, see Xtreme Temperature Silicon Capacitor product: XTSC
 (***) Other values on request.

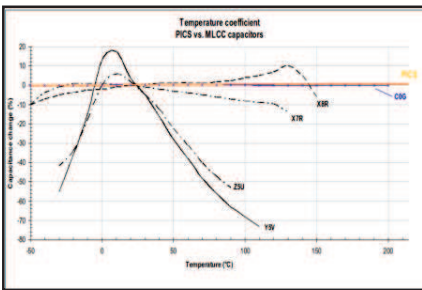

Fig.1 Capacitance change versus temperature variation compared with alternative dielectrics

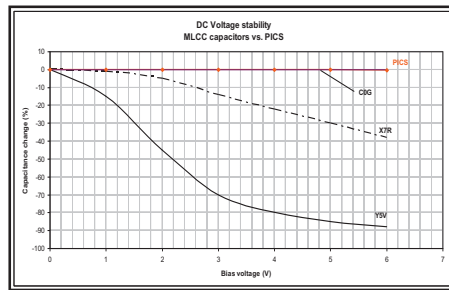

Fig.2 Capacitance change versus voltage variation compared with alternative dielectrics

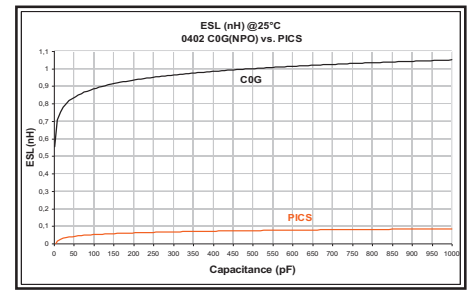

Fig.3 ESL versus capacitance value compared with alternative dielectrics

Part Number

935.132. **B.2** → Breakdown Voltage (4 = 11V) **S.** → Size (6 = 0805) **U** → Unit (0 = 10f, 1 = 0.1p, 2 = 1p, 3 = 10p, 4 = 0.1n) **XX** → Value (E6) (5 = 1n, 6 = 10n, 7 = 0.1u, 8 = 1u, 9 = 10u)

i.e.: 100 nF/0805 case (HTSC type)
 → 935.132.426.610

Termination and Outline

Termination
 Lead-free nickel/solder coating compatible with automatic soldering technologies: reflow and manual.

Typical dimensions, all dimensions in mm.

Package outline

Typ.		0805
Comp. size	L	2.20±0.05
	W	1.40±0.05

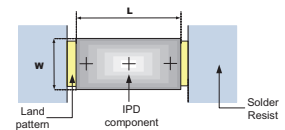

(0805 PCB footprint)

Packaging

Tape and reel, tray, waffle pack or wafer delivery.

Reproduction in whole or in part is prohibited without the prior written consent of the copyright owner. The information presented in this document does not form part of any quotation or contract, is believed to be accurate and reliable and may be changed without notice. No liability will be accepted by the publisher for any consequence of its use. Publication thereof does not convey nor imply any license under patent- or other industrial or intellectual property rights.



For more information, please visit: <http://www.ipdia.com>
 To contact us, email to: sales@ipdia.com

Date of release: 2nd September 2013
 Document identifier: CL431 111 615 130



IPD Capacitor Assembly Set Up

Rev 1.0

Application Note

Outline

Silicon Capacitor for surface mounting device (SMD) assembly is a Wafer Level Chip Scale Packaging with the following features:

- Package dedicated to solve tombstoning effect of small SMD package;
- Package compatible with SMD assembly;
- Package without underfilling step;
- Interconnect available with various optional finishing for specific assembly.

Assembly consideration

- Standard pick & place equipment dedicated to WLCSP down to 400µm pitch.
- Solder paste type 3 in most cases of EIA size.
- Reflow has to be done with standard lead-free profile (for SAC alloys) or according to JEDEC recommendations J-STD 020D-01.

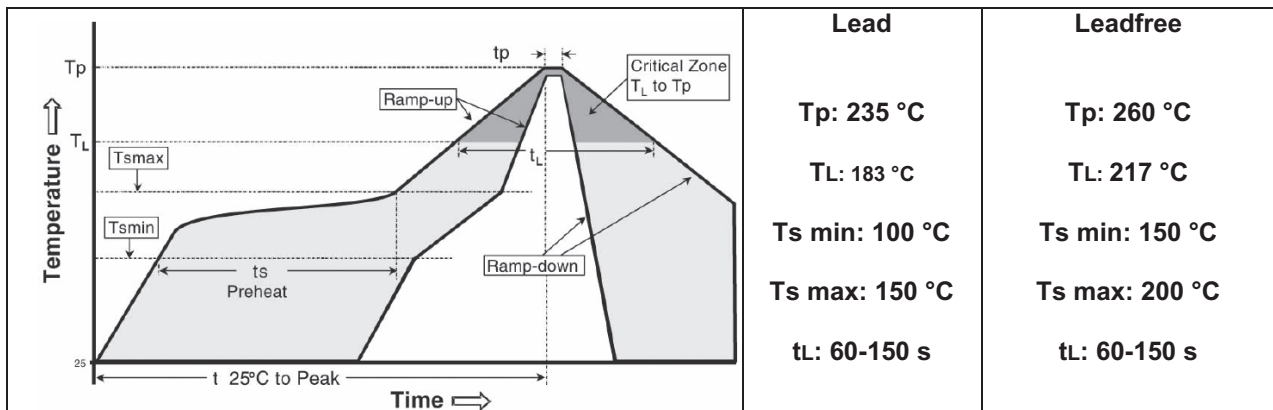

Process recommendation

After soldering, no solder paste should touch the side of the capacitor die as that might results in leakage currents due to remaining flux.

In order to use IPDiA standard capacitors within the JEDEC format and recommendation, the solder flux must be cleaned after reflow soldering step.

Notes: for a proper flux cleaning process, "rosin" flux type (R) or "water soluble" flux type (WS) is recommended for the solder printing material. "No clean" flux (NC) solder paste is not recommended.

In case the flux is not cleaned after the reflow soldering, the standard JEDEC would probably not be appropriate and the solder volume must be controlled:

- using smallest aperture design for the stencil, and using finer solder paste type 4 or 5 for a proper printing process.
- Mirroring pads would be the best recommendation

Pad recommendation

The capacitor is compatible with generic requirements for flip chip design (IPC7094). Standard IPDiA 3D package can be compliant with established EIA size (0201, 0402, 0603, ...).

Die size and land pattern dimensions is set up according to following range :

EIA size	0201	0402	0603	0805	1206	1812
Dimension max(X1 x X2) mm	0.86x0.66	1.26x0.76	1.86x1.16	2.26x1.46	3.46x1.86	4.76x3.66
Typical . die thickness X3 (mm)	0.1 or 0.4					
Typical pad size* (mm)	0.15x0.40	0.30x0.50	0.40x0.90	0.50x1.20	0.60x1.60	0.90x3.40
Typical pad separation (X4 mm)	0.3	0.4	0.8	1	2	2.7

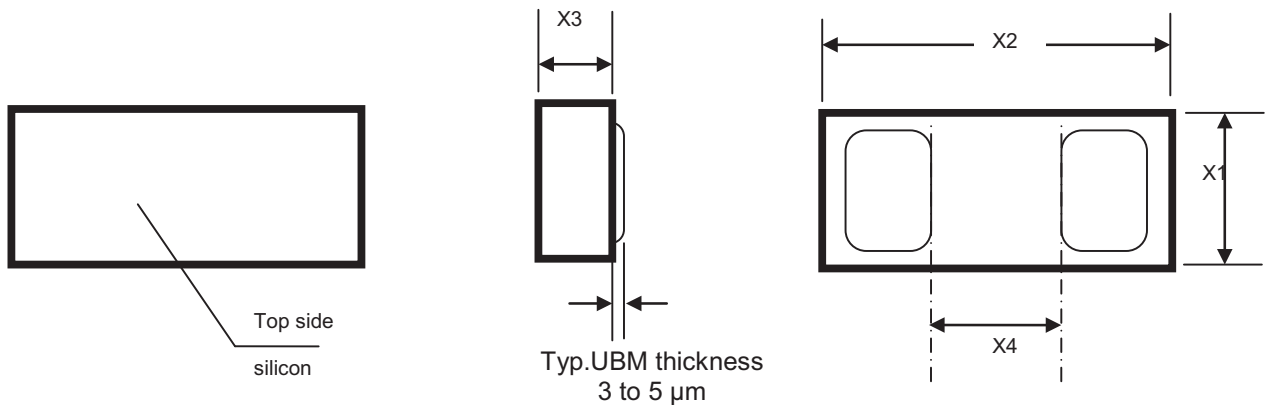

After soldering, no solder paste should touch the side of the capacitor die as that might result in leakage currents due to remaining flux.

Manual Handling Considerations

These capacitors are designed to be mounted with a standard SMT line, using solder printing step, pick and place machine and a final reflow soldering step. In case of manual handling and mounting conditions, please follow below recommendations:

- Minimize mechanical pressure on the capacitors (use of a vacuum nozzle is recommended).
- Use of organic tip instead of metal tip for the nozzle.
- Minimize temperature shocks (Substrate pre-heating is recommended).
- No wire bonding on 0402 47nF, 0402 100nF, 1206 1 μ F and 1812 3,3 μ F

Process steps:

- On substrate, form the solder meniscus on each land pattern targeting 100 μ m height after reflow (screen printing, dispensing solder paste or by wire soldering).
- Pick the capacitor from the tape & reel or the Gel Pack keeping backside visible using a vacuum nozzle and organic tip.
- Temporary place the capacitor on land pattern assuming the solder paste (Flux) will stick and maintain the capacitor.
- Reflow the assembly module with a dedicated thermal profile (see reflow recommendation profile).