

Analog Devices Welcomes Hittite Microwave Corporation

NO CONTENT ON THE ATTACHED DOCUMENT HAS CHANGED



THIS PAGE INTENTIONALLY LEFT BLANK



GaAs MMIC x2 ACTIVE FREQUENCY MULTIPLIER MODULE, 32 - 46 GHz OUTPUT

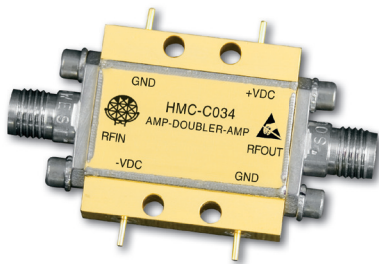

Typical Applications

The HMC-C034 is suitable for:

- Clock Generation Applications:
SOWET OC-192 & SDH STM-64
- Point-to-Point & VSAT Radios
- Test Instrumentation
- Military EW/Radar
- Space

Functional Diagram

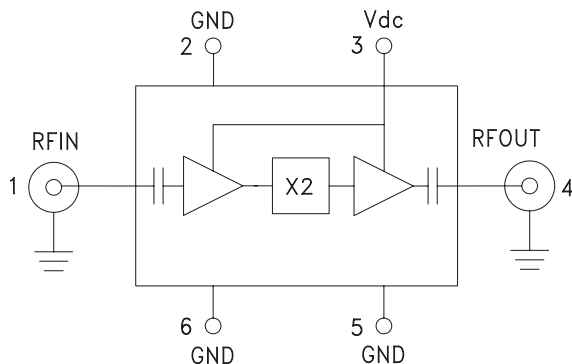

Features

- High Output Power: +13 dBm
- Low Input Power Drive: 0 to +6 dBm
- 100 KHz SSB Phase Noise: -130 dBc/Hz
- Fo Isolation >30 dBc @ Fout = 38 GHz
- Single Supply: +5V @ 70 mA
- Hermetically Sealed Module
- Field Replaceable 2.92mm Connectors
- 55 °C to +85 °C Operating Temperature

General Description

The HMC-C034 is a x2 active broadband frequency multiplier utilizing GaAs PHEMT technology in a miniature hermetic module. When driven by a 3 dBm signal, the multiplier provides +13 dBm typical output power from 32 to 46 GHz. The Fo isolation is >30 dBc with respect to output signal level. This frequency multiplier features DC blocked I/O's, and is ideal for use in LO multiplier chains for Pt to Pt & VSAT Radios yielding reduced parts count vs. traditional approaches. The low additive SSB Phase Noise of -130 dBc/Hz at 100 kHz offset helps maintain good system noise performance.

Electrical Specifications, $T_A = +25^\circ \text{C}$, $V_{dc} = +5\text{V}$, 3 dBm Drive Level

Parameter	Min.	Typ.	Max.	Units
Frequency Range, Input		16 - 23		GHz
Frequency Range, Output		32 - 46		GHz
Output Power	8	13		dBm
Fo Isolation (with respect to output level)		30		dBc
Input Return Loss		12		dB
Output Return Loss		8		dB
SSB Phase Noise (100 kHz Offset)		-130		dBc/Hz
Supply Current		70		mA



GaAs MMIC x2 ACTIVE FREQUENCY MULTIPLIER MODULE, 32 - 46 GHz OUTPUT

Output Power vs. Temperature @ 3 dBm Drive Level

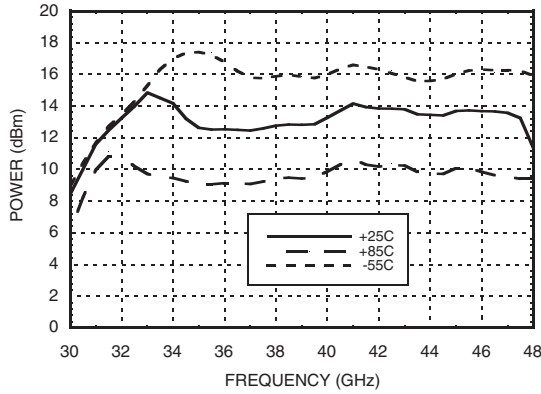

Output Power vs. Drive Level

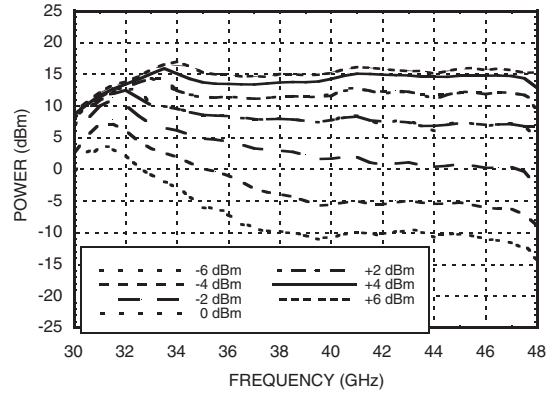

Output Power vs. Supply Voltage @ 3 dBm Drive Level

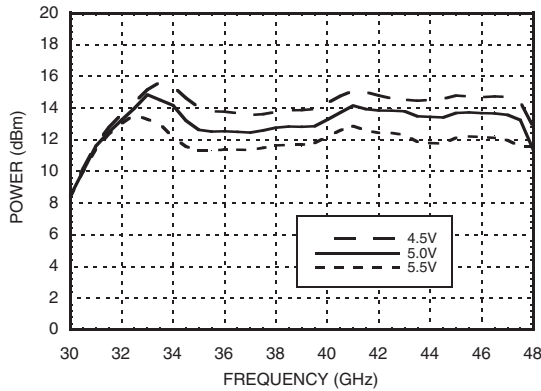

Isolation @ 3 dBm Drive Level

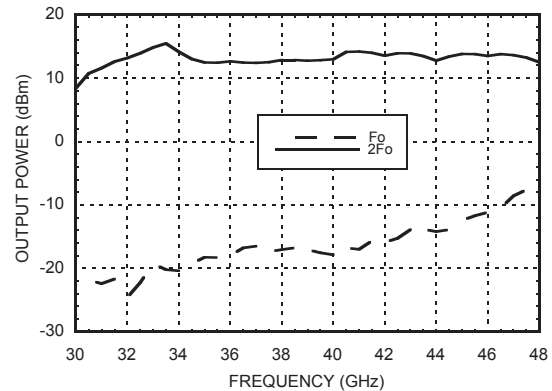

Output Power vs. Input Power

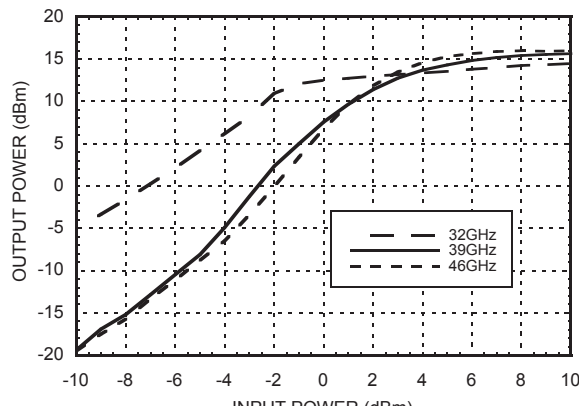



GaAs MMIC x2 ACTIVE FREQUENCY MULTIPLIER MODULE, 32 - 46 GHz OUTPUT

Input Return Loss vs. Temperature @ 0 dBm Drive Level

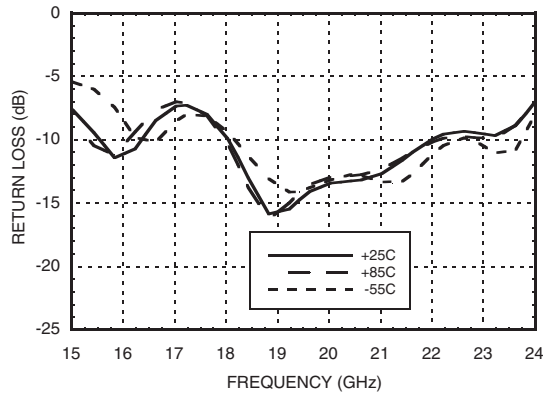

Output Return Loss vs. Temperature @ 0 dBm Drive Level

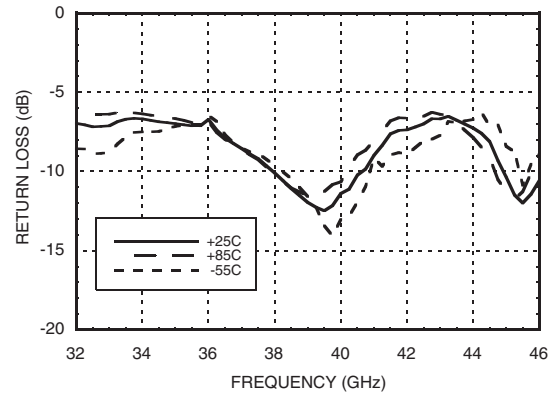

Absolute Maximum Ratings

RF Input (Vdc = +5V)	+13 dBm
Bias Supply Voltage (Vdc)	+6 Vdc
Storage Temperature	-65 to +150 °C
Operating Temperature	-55 to +85 °C

Typical Supply Current vs. Vdd

Vdd (Vdc)	Idd (mA)
4.5	69
5.0	70
5.5	70

Note:
Multiplier will operate over full voltage range shown above.



**ELECTROSTATIC SENSITIVE DEVICE
OBSERVE HANDLING PRECAUTIONS**

Pin Description

Pin Number	Function	Description	Interface Schematic
1	RFIN and RF Ground	Pin is AC coupled and matched to 50 Ohms. RFIN uses a female 2.92mm field replaceable connector.	
2, 5, 6	GND	One of these pins must be connected to power supply ground.	
3	Vdc	Power supply voltage for the amplifier includes a 7.5V zener diode for over voltage and negative voltage protection	
4	RFOUT and RF Ground	Pin is AC coupled and matched to 50 Ohms. RFOUT uses a female 2.92mm field replaceable connector.	

For price, delivery, and to place orders, please contact Hittite Microwave Corporation:
20 Alpha Road Chelmsford, MA 01824 Phone: 978-250-3343 Fax: 978-250-3373
Order Online at www.hittite.com



GaAs MMIC x2 ACTIVE FREQUENCY MULTIPLIER MODULE, 32 - 46 GHz OUTPUT

Outline Drawing

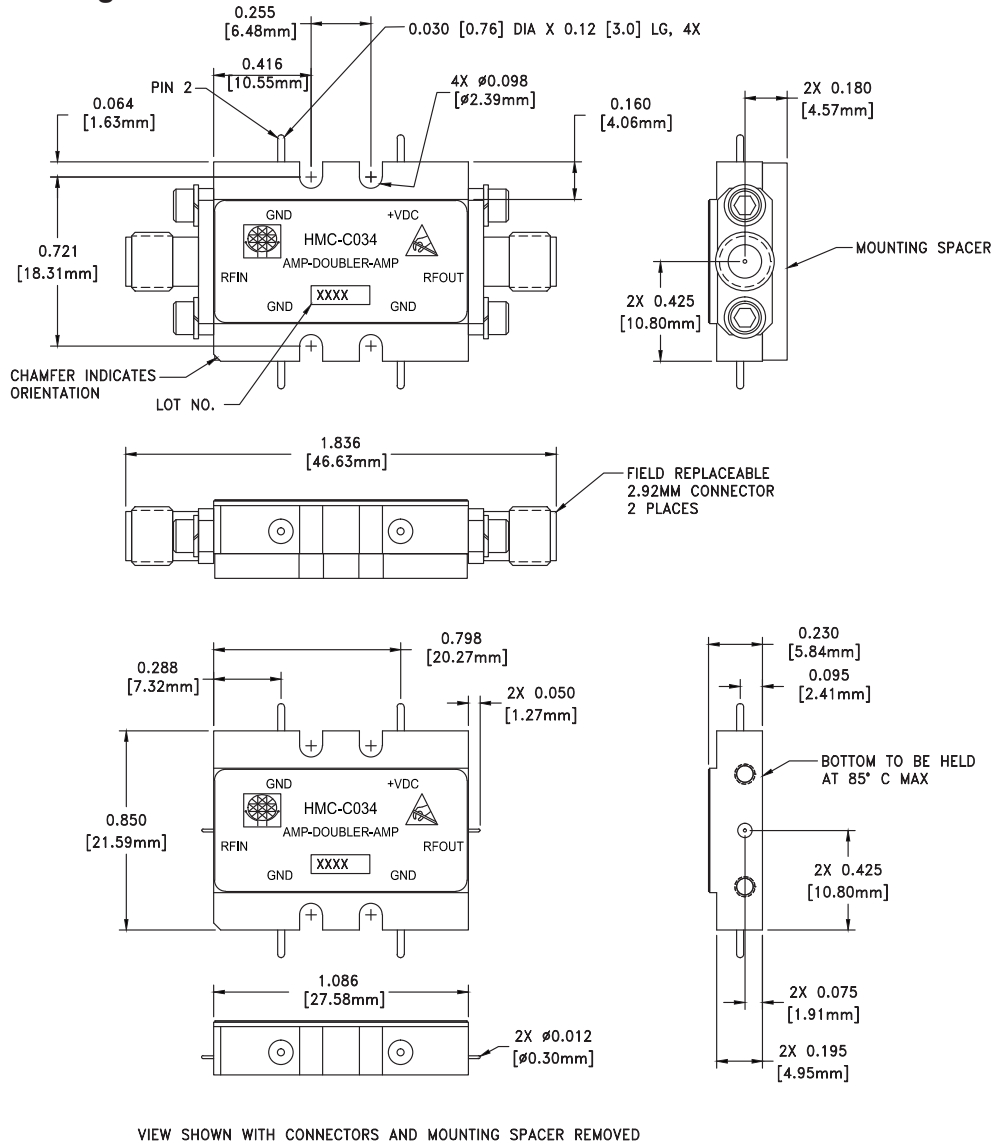

Package Information

Package Type	C-10
Package Weight [1]	18.7 gms [2]
Spacer Weight	3.3 gms [2]

[1] Includes the connectors

[2] ±1 gms Tolerance

NOTES:

1. PACKAGE, LEADS, COVER MATERIAL: KOVAR
2. PLATING: ELECTROLYTIC GOLD 50 MICROINCHES MIN., OVER ELECTROLYTIC NICKEL 75 MICROINCHES MIN.
3. MOUNTING SPACER: NICKEL PLATED ALUMINUM
4. ALL DIMENSIONS ARE IN INCHES [MILLIMETERS]
5. TOLERANCES: 0.010 [0.25] UNLESS OTHERWISE SPECIFIED