

PROTECTION PRODUCTS

Description

The LC04-6 has been specifically designed to protect sensitive components which are connected to high-speed telecommunications lines from over voltages caused by **lightning**, electrostatic discharge (**ESD**), cable discharge events (**CDE**), and electrical fast transients (**EFT**).

The device is in a JEDEC SO-16 NB package. It is designed to provide metallic surge protection for two tip and ring line pairs. The low capacitance topology means signal integrity is preserved on high-speed lines. The high surge capability (1000W, $t_p=10/1000\mu s$) makes the LC04-6 suitable for telecommunications systems operating in harsh transient environments.

The LC04-6 is designed to meet the lightning surge requirements of Bellcore GR-1089 (Intra-building), FCC Part 68, ITU K.20, and IEC 61000-4-5. The features of the LC04-6 are ideal for protecting T1/E1 transceivers in WAN applications.

Features

- ◆ Transient protection for high-speed data lines to
 - Bellcore GR-1089 $I_{pp}=70A$ (10/1000 μs)**
 - Bellcore GR 1089 $I_{pp}=100A$ (2/10 μs)**
 - ITU K.20 $I_{pp}=100A$ (5/310 μs)**
 - IEC 61000-4-2 (ESD) $\pm 15kV$ (air), $\pm 8kV$ (contact)**
 - IEC 61000-4-4 (EFT) 40A (5/50ns)**
 - IEC 61000-4-5 (Lightning) 100A (8/20 μs)**
- ◆ Protects two tip and ring line pairs
- ◆ Low capacitance for high-speed interfaces
- ◆ High surge capability
- ◆ Low clamping voltage
- ◆ Solid-state silicon avalanche technology

Mechanical Characteristics

- ◆ JEDEC SO-16 package
- ◆ Molding compound flammability rating: UL 94V-0
- ◆ Lead Finish: Matte Tin
- ◆ Marking : Part number, date code, logo
- ◆ Pb-Free, Halogen Free, RoHS/WEEE Compliant
- ◆ Packaging : Tube or Tape and Reel

Applications

- ◆ T1/E1 Line Cards
- ◆ Base Stations
- ◆ WAN Equipment
- ◆ CSU/DSU
- ◆ Multiplexers
- ◆ Routers
- ◆ ISP Equipment
- ◆ Customer Premise Equipment

Circuit Diagram

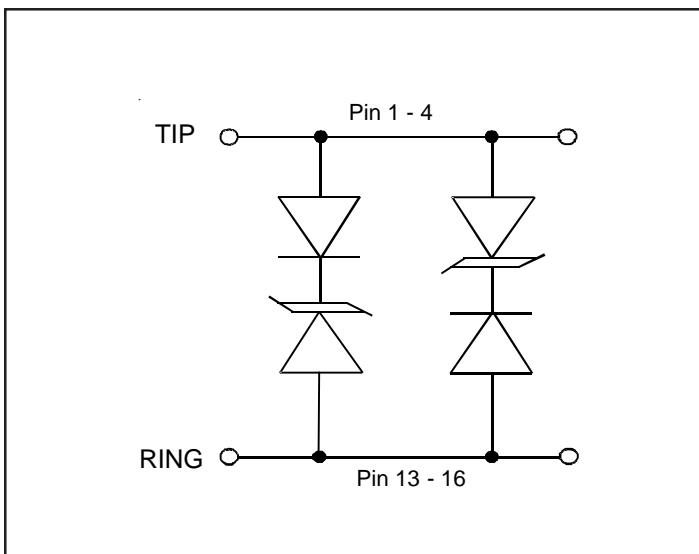

Schematic & PIN Configuration

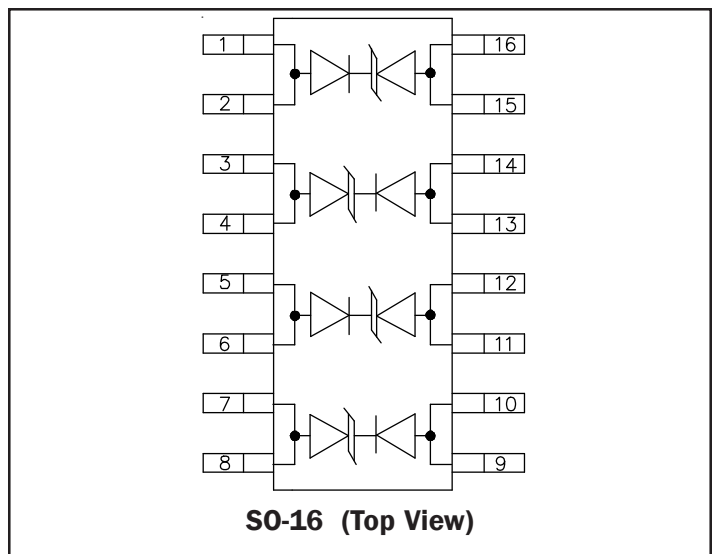

PROTECTION PRODUCTS
Absolute Maximum Rating

Rating	Symbol	Value	Units
Peak Pulse Power ($t_p = 10/1000\mu s$)	P_{pk}	1000	Watts
Peak Pulse Current ($t_p = 10/1000 \mu s$)	I_{pp}	70	A
Peak Pulse Current ($t_p = 8/20\mu s$)	I_{pp}	200	A
Peak Pulse Current ($t_p = 10/560\mu s$)	I_{pp}	100	A
Lead Soldering Temperature	T_L	260 (10 sec.)	°C
Operating Temperature	T_J	-55 to +125	°C
Storage Temperature	T_{STG}	-55 to +150	°C

Electrical Characteristics

LC04-6						
Parameter	Symbol	Conditions	Minimum	Typical	Maximum	Units
Reverse Stand-Off Voltage	V_{RWM}				6	V
Reverse Breakdown Voltage	V_{BR}	$I_t = 1mA$	6.8			V
Reverse Leakage Current	I_R	$V_{RWM} = 6V, T=25^\circ C$			15	μA
		$V_{RWM} = 3V, T=25^\circ C$			2	μA
Clamping Voltage	V_C	$I_{pp} = 10A,$ $t_p = 10/1000\mu s$			12.5	V
Clamping Voltage	V_C	$I_{pp} = 70A,$ $t_p = 10/1000\mu s$			15	V
Clamping Voltage	V_C	$I_{pp} = 100A,$ $t_p = 8/20\mu s$			20	V
Junction Capacitance	C_j	Each Line $V_R = 0V, f = 1MHz$			15	pF

PROTECTION PRODUCTS

Typical Characteristics

Non-Repetitive Peak Pulse Power vs. Pulse Time

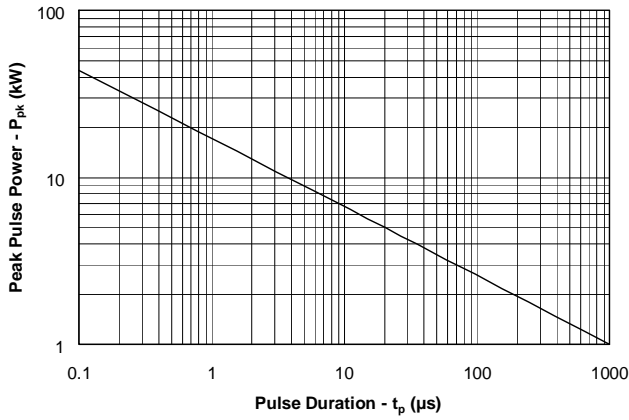

Power Derating Curve

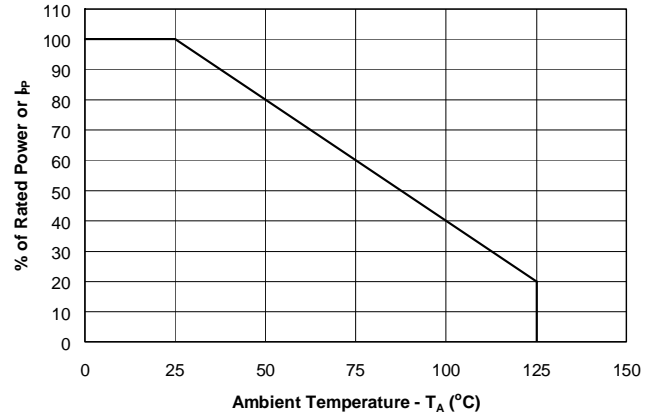

Pulse Waveform

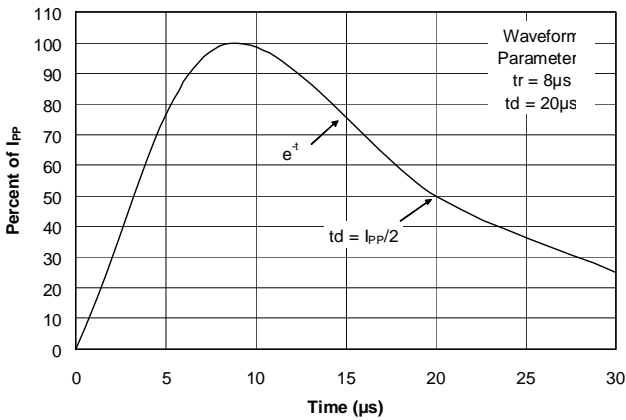

Clamping Voltage vs. Peak Pulse Current

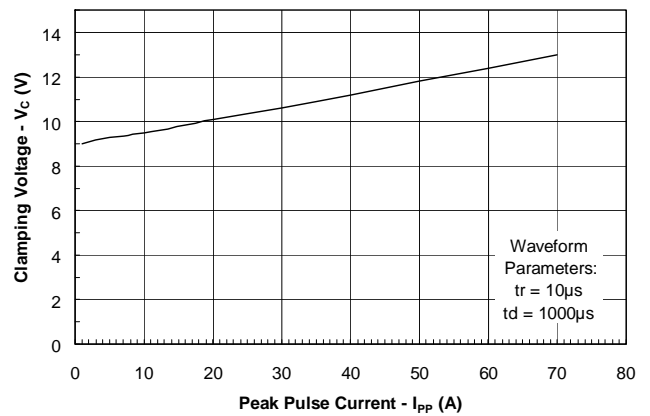

Capacitance vs. Reverse Voltage

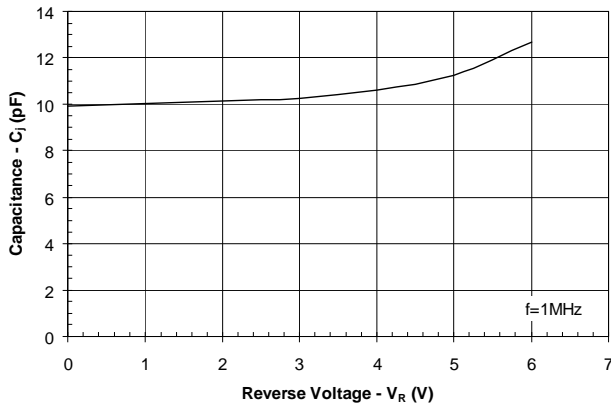

Clamping Voltage vs. Peak Pulse Current

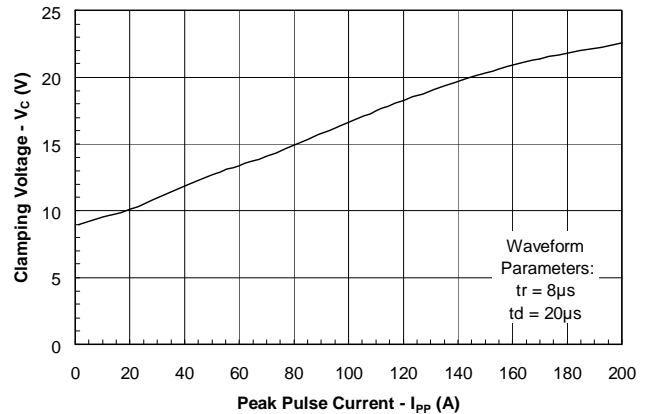

PROTECTION PRODUCTS

Applications Information

Device Connection Options for Protection of Two High-Speed Line Pairs

The LC04-6 is designed to protect four high-speed data lines (two differential pairs) from transient over-voltages which result from lightning and ESD. Protection of two line pairs is achieved by connecting the device as follows: Pins 1-4 are connected to line 1 of the first pair (i.e. Tip 1) and pins 13-16 are connected to line 2 of the first pair (i.e. Ring 1). Pins 5-8 are connected to line 1 of the second pair (i.e. Tip 2) and pins 9-12 are connected to line two of the second pair (i.e. Ring 2). All pins should be connected for best results. Minimize parasitic inductance in the protection circuit path by keeping the trace length between the protected line and the LC04-6 as short as possible.

T1/E1 Linecard Protection

A typical T1/E1 linecard protection circuit is shown in Figure 2. The LC04-6 is connected between Tip and Ring on the transmit and receive line pairs. It provides protection to metallic (line-to-line) lightning and ESD surges. It is designed to meet the intra-building requirements of Bellcore GR-1089. This design takes advantage of the isolation of the transformer to suppress common mode surges. The LC04-6 may also be configured to meet metallic surges of FCC Part68 when used in conjunction with a 5Ω (minimum) PTC or line feed resistor (LFR). The PTC (or LFR + fuse) are required to meet the AC power cross requirements, but will also reduce the effective surge current to levels within the capability of the LC04-6 (Table 1). To complete the protection circuit, the SRDA05-4 (or SRDA3.3-4 for 3.3V supplies) is employed as the IC side protection element. This device helps prevent the transceiver from latching up by providing fine clamping of transients that are coupled through the transformer. The versatility of the LC04-6 makes it ideal for use with combination long haul/short haul T1/E1 transceivers.

Figure 1 - Connection for Differential (Line-to-Line) Protection of two Tip/Ring Line Pairs

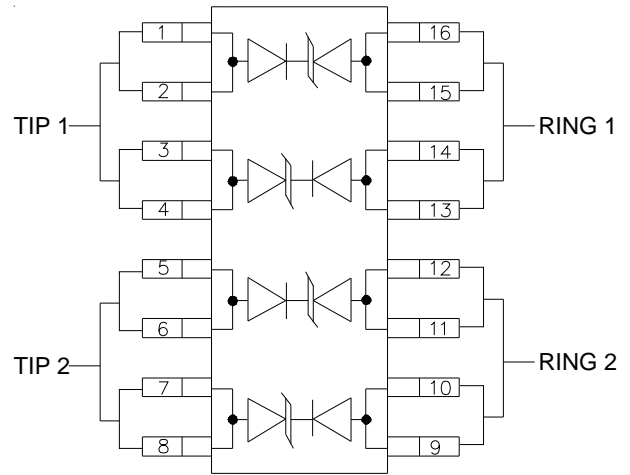

Matte Tin Lead Finish

Matte tin has become the industry standard lead-free replacement for SnPb lead finishes. A matte tin finish is composed of 100% tin solder with large grains. Since the solder volume on the leads is small compared to the solder paste volume that is placed on the land pattern of the PCB, the reflow profile will be determined by the requirements of the solder paste. Therefore, these devices are compatible with both lead-free and SnPb assembly techniques. In addition, unlike other lead-free compositions, matte tin does not have any added alloys that can cause degradation of the solder joint.

PROTECTION PRODUCTS

Typical Applications

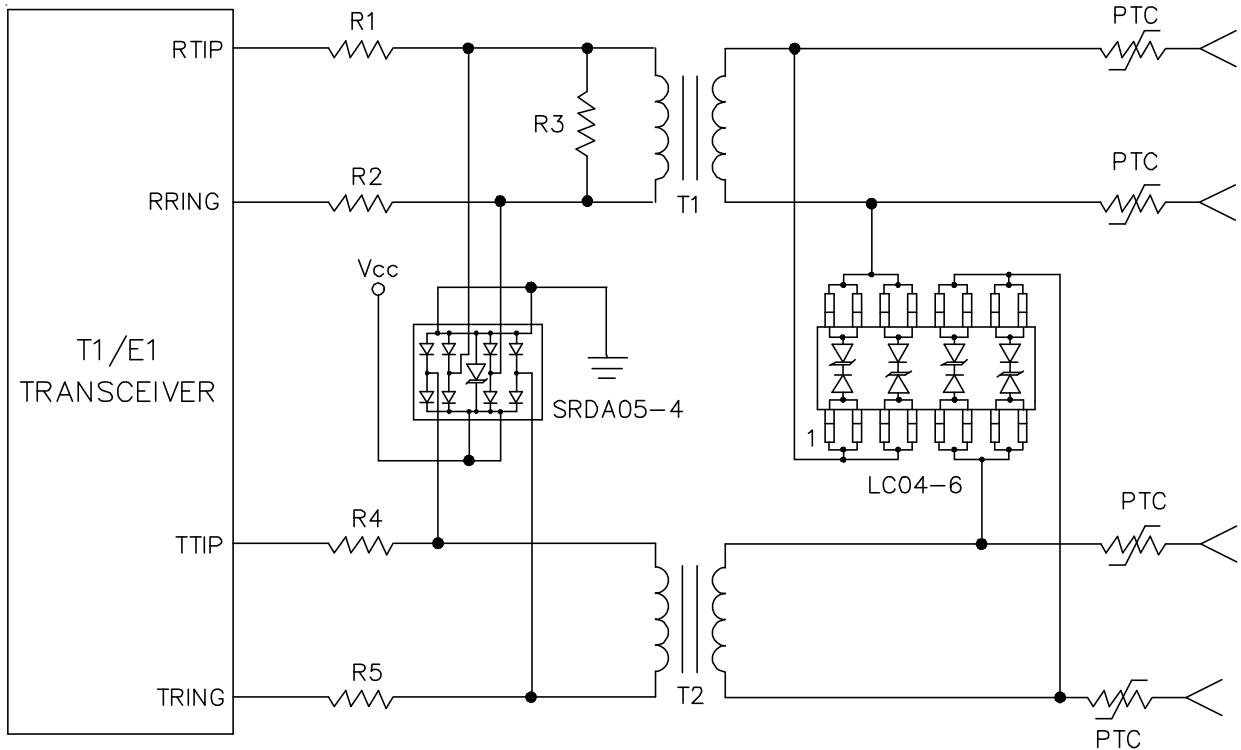

Figure 2 - T1/E1 Line Card protection

Immunity Standard	Peak Open Circuit Surge Voltage (V)	Current Waveform (µs)	Peak Short Circuit Surge Current (A)	Surge Generator Source Resistance (W)	Total Source Resistance (with 5W PTC or LFC) (W)	Effective Short Circuit Current (A)
Bellcore GR-1089 Intra-Building	800	2/10	100	8	13	61.5
FCC Part 68	1500	10/160	200	7.5	12.5	120

Table 1

PROTECTION PRODUCTS

Outline Drawing - S0-16

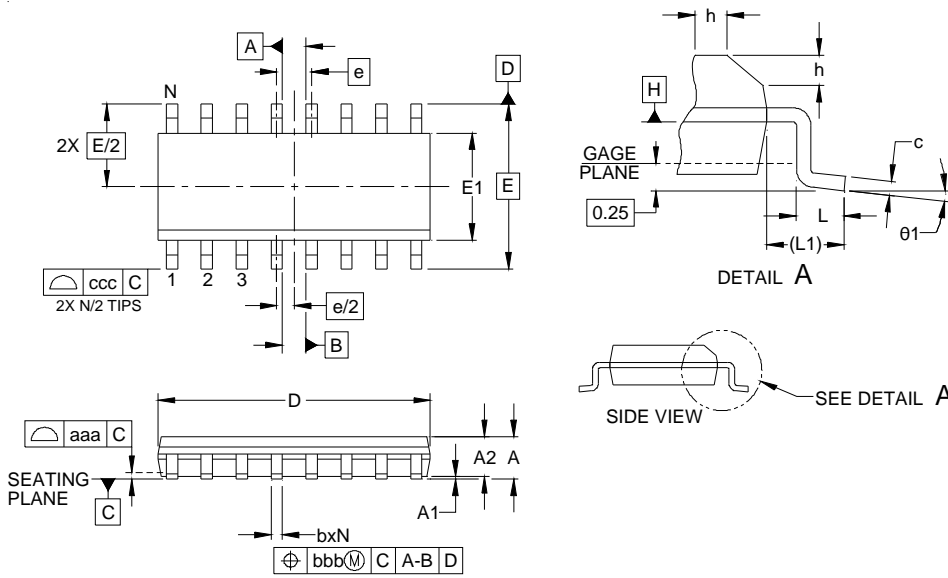

DIM	INCHES			MILLIMETERS		
	MIN	NOM	MAX	MIN	NOM	MAX
A	.053	-	.069	1.35	-	1.75
A1	.004	-	.010	0.10	-	0.25
A2	.049	-	.065	1.25	-	1.65
b	.012	-	.020	0.31	-	0.51
c	.007	-	.010	0.17	-	0.25
D	.386	.390	.394	9.80	9.90	10.00
E1	.150	.154	.157	3.80	3.90	4.00
E	.236 BSC			6.00 BSC		
e	.050 BSC			1.27 BSC		
h	.010	-	.020	0.25	-	0.50
L	.016	.028	.041	0.40	0.72	1.04
L1	(.041)			(1.04)		
N	16			16		
θ1	0°	-	8°	0°	-	8°
aaa	.004			0.10		
bbb	.010			0.25		
ccc	.008			0.20		

- NOTES:
1. CONTROLLING DIMENSIONS ARE IN MILLIMETERS (ANGLES IN DEGREES).
 2. DATUMS **-A-** AND **-B-** TO BE DETERMINED AT DATUM PLANE **-H-**
 3. DIMENSIONS "E1" AND "D" DO NOT INCLUDE MOLD FLASH, PROTRUSIONS OR GATE BURRS.
 4. REFERENCE JEDEC STD MS-012, VARIATION AC.

Land Pattern - S0-16

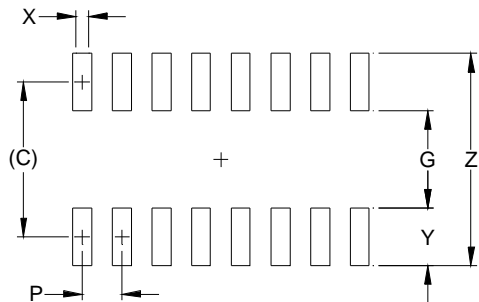

DIM	DIMENSIONS	
	INCHES	MILLIMETERS
C	(.205)	(5.20)
G	.118	3.00
P	.050	1.27
X	.024	0.60
Y	.087	2.20
Z	.291	7.40

- NOTES:
1. THIS LAND PATTERN IS FOR REFERENCE PURPOSES ONLY. CONSULT YOUR MANUFACTURING GROUP TO ENSURE YOUR COMPANY'S MANUFACTURING GUIDELINES ARE MET.
 2. REFERENCE IPC-SM-782A, RLP NO. 304A.

PROTECTION PRODUCTS

Marking Diagram

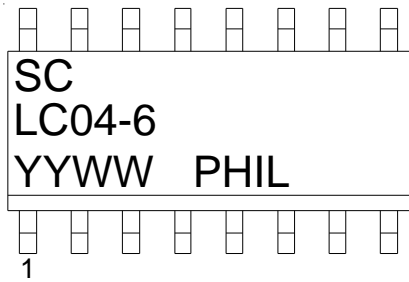

Note:
YYWW = Date Code

Ordering Information

Part Number	Lead Finish	Qty per Reel	Reel Size
LC04-6.TBT	Pb Free	500	7 Inch
LC04-6.T	Pb Free	48/Tube	N/A

Contact Information

Semtech Corporation
 Protection Products Division
 200 Flynn Rd., Camarillo, CA 93012
 Phone: (805)498-2111 FAX (805)498-3804