

GaAs IC Control FET Series

DC–2.5 GHz



AF002C1-39, AF002C4-39

Features

- Low Cost SOT-23 Package
- Series or Shunt Configuration
- Low DC Current Drain
- Ideal Switch Building Blocks
- Pin Diode Replacements
- High Power Antenna Switches

SOT-23

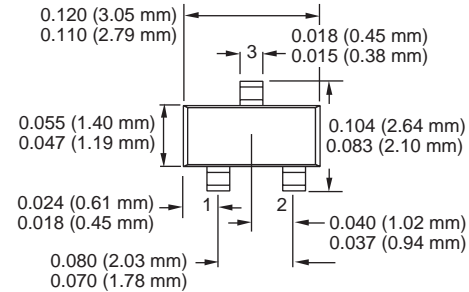

Description

This group of GaAs control FETs can be used in both series and shunt configurations. They incorporate on-chip circuitry that eliminates the need for extra bias components and minimizes power drain to typically 25 μ W. These features make the device ideal replacements for PIN diodes, where low DC drain is critical.

Isolation performance degrades at higher frequencies due to package parasitics. They can be tuned out in narrow band applications as shown in the circuit examples on the following pages.

Electrical Specifications at 25°C (0, -5 V)

Part Number ¹	Frequency ² (GHz)	R_{ON} (Ω) ³		Insertion Loss (dB) ^{4,5}		C_{OFF} (pF) ⁶		Isolation (dB) ⁵		P_{-1} dB (W)
		Typ.	Max.	Series	Shunt	Typ.	Max.	Series	Shunt	Typ.
AF002C1-39	DC–0.5 GHz	6.4	9.0	0.50	0.10	0.13	0.25	25	12	0.5
	DC–1.0 GHz	6.4	9.0	0.60	0.15	0.13	0.25	17	8	1.0
	DC–2.5 GHz	6.4	9.0	0.70	0.20	0.13	0.25	13	3	1.0
AF002C4-39	DC–0.5 GHz	0.8	1.1	0.20	0.15	1.10	1.50	11	15	6
	DC–1.0 GHz	0.8	1.1	0.25	0.25	1.10	1.50	6	9	10
	DC–2.5 GHz	0.8	1.1	0.30	2.00	1.10	1.5	3	4	10

Operating Characteristics at 25°C (0, -5 V)

Parameter	Condition	Frequency	Min.	Typ.	Max.	Unit
Switching Characteristics	Rise, Fall (10/90% or 90/10% RF)			6		ns
	On, Off (50% CTL to 90/10% RF)			12		ns
Control Voltages	$V_{Low} = 0$ to -0.2 V @ 20 μ A Max. $V_{High} = -5$ V @ 50 μ A to -9 V @ 200 μ A Max.					

1. All measurements made in a 50 Ω system, unless otherwise specified.
2. DC = 300 kHz.
3. R_{ON} - resistance in Ω in low impedance state when "0" V is applied to Gate (G).
4. Insertion loss changes by 0.003 dB/°C.
5. Insertion loss and isolation typical values.
6. C_{OFF} - capacitance (pF) in high impedance state when -5 V is applied to Gate (G).

Typical Performance Data (0, -5 V)

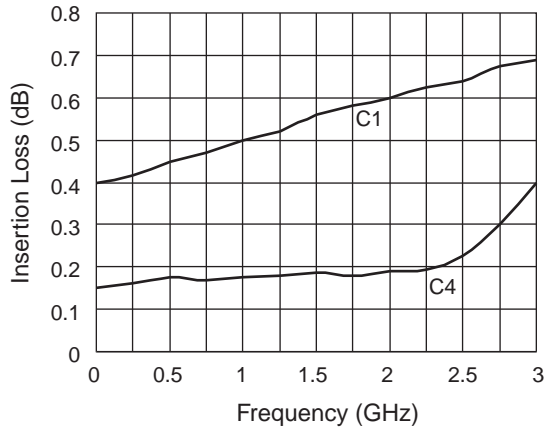

**Insertion Loss vs. Frequency
Series Configuration**

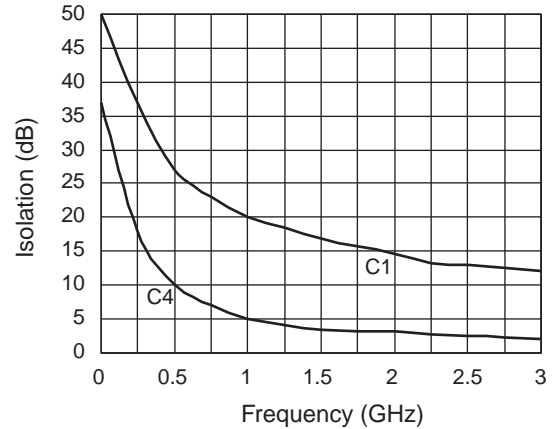

**Isolation vs. Frequency
Series Configuration**

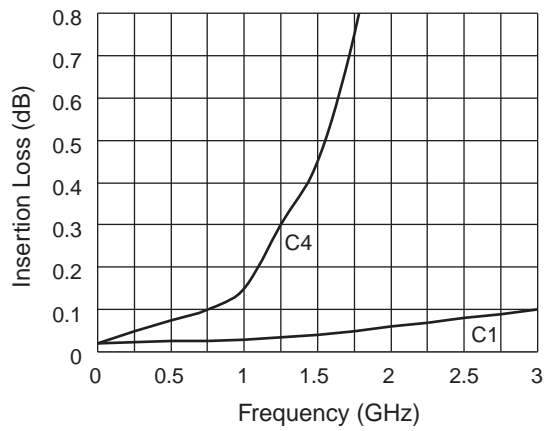

**Insertion Loss vs. Frequency
Shunt Configuration**

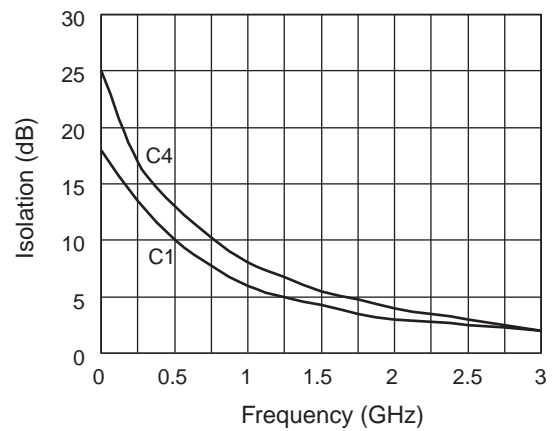

**Isolation vs. Frequency
Shunt Configuration**

Absolute Maximum Ratings

AF002C1-39

Characteristic	Value
RF Input Power	2 W > 500 MHz 0/-8 V 0.5 W @ 50 MHz 0/-8 V
Control Voltage	+0.2 V, -10 V
Operating Temperature	-40°C to +85°C
Storage Temperature	-65°C to +150°C
θ_{JC}	25°C/W

Note: Exceeding these parameters may cause irreversible damage.

AF002C4-39

Characteristic	Value
RF Input Power	12 W > 450 MHz, 0/-12 V
Control Voltage	+0.2, -12 V
Operating Temperature	-40°C to +85°C
Storage Temperature	-65°C to +150°C
θ_{JC}	25°C/W

T/R and Antenna Changeover Switch for Mobile Cellular Systems

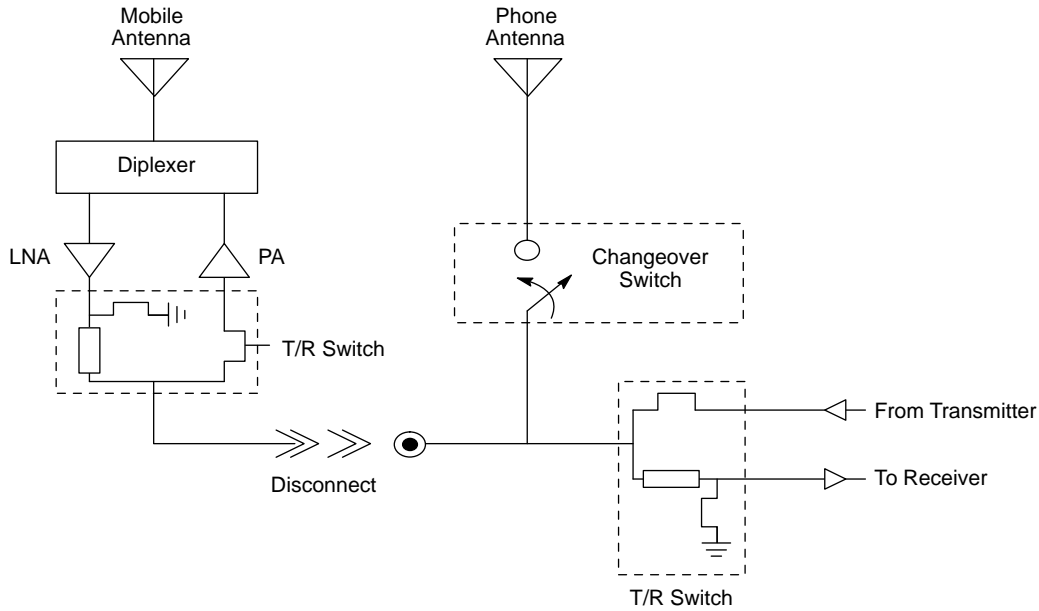

System Block Diagram

T/R Switch Schematic

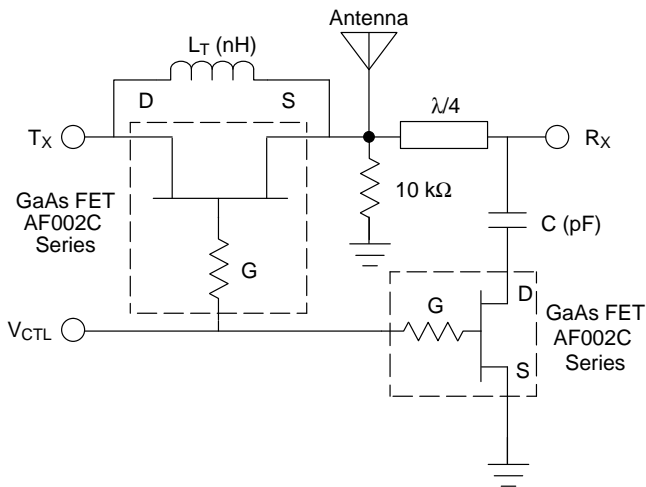

Changeover Switch Schematic

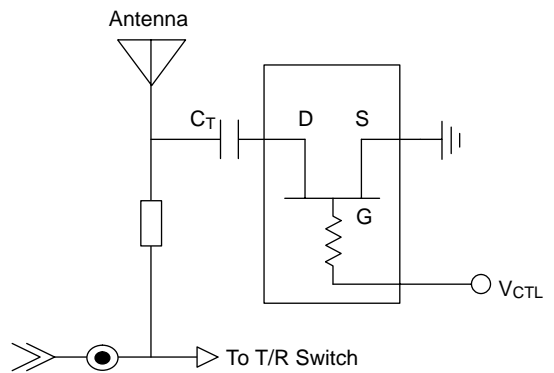

Truth Table for T/R Switch

V_{CTL} (V)	T_x to Antenna	R_x to Antenna
0	Low Loss	High Isolation
-5	High Isolation	Low Loss

See next page for positive voltage operation.

Truth Table for Changeover Switch

V_{CTL} (V)	Antenna
-5	Connected
0	Isolated

See next page for positive voltage operation.

Component Values for T/R Switch Circuit

Part Number	L_T (nH)	C_T (pF)	Freq. (GHz)
AF002C1-39	165	18.8	0.45
AF002C4-39	85	18.8	0.45
AF002C1-39	44	4.7	0.90
AF002C4-39	22	4.7	0.90

Pin Out

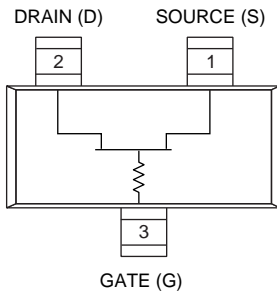

Positive Voltage Operation

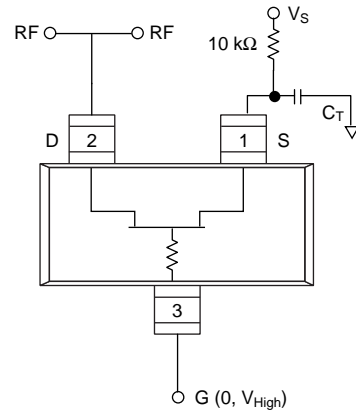

Shunt Configuration

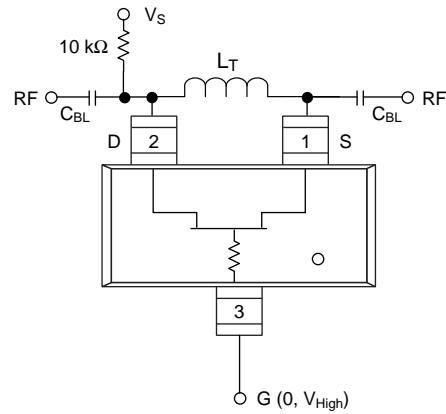

C_{BL} - Chose value for lowest impedance at desired operating frequency.

Series Configuration

Truth Table

Negative Voltage Operation

S	D	G	RF Path
Shunt			
GND	RF	-5	Insertion Loss
		0	Isolation
Series			
RF	RF	0	Insertion Loss
		-5	Isolation

Positive Voltage Operation

S	D	G	RF Path
Shunt			
GND	RF	0	Insertion Loss
		V_{High}	Isolation
Series			
RF	RF	0	Isolation
		V_{High}	Insertion Loss

$V_{High} = +5$ to $+9$ V ($V_S = V_{High} \pm 0.2$ V).