

Single Phase Bi-directional Power / Energy Metering IC with Instantaneous Pulse Output

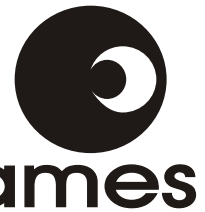

SA2002H

FEATURES

- Functionally compatible with the SA9602H with reduced external components
- Bi-directional power and energy measurement
- Meets the IEC 521/1036 Specification requirements for Class 1 AC Watt hour meters
- Protected against ESD
- Total power consumption rating below 25mW
- Adaptable to different types of current sensors
- Operates over a wide temperature range
- Precision voltage reference on-chip
- Precision oscillator on-chip

DESCRIPTION

The SAMES SA2002H is an enhancement of the SA9602H, as the circuit contains the oscillator on chip.

The SAMES SA2002H single phase bi-directional power/energy metering integrated circuit generates a pulse rate output with a frequency proportional to the power consumption.

The SA2002H performs a calculation for active power. The method of calculation takes the power factor into account. Energy consumption can be determined by the power measurement being integrated over time.

This innovative universal single-phase power/energy metering integrated circuit is ideally suited for energy calculations in applications such as residential municipal metering and factory energy metering and control.

The SA2002H integrated circuit is available in 8, 14 and 20 pin dual-in-line plastic (DIP) as well as 16 and 20 pin small outline (SOIC) package types.

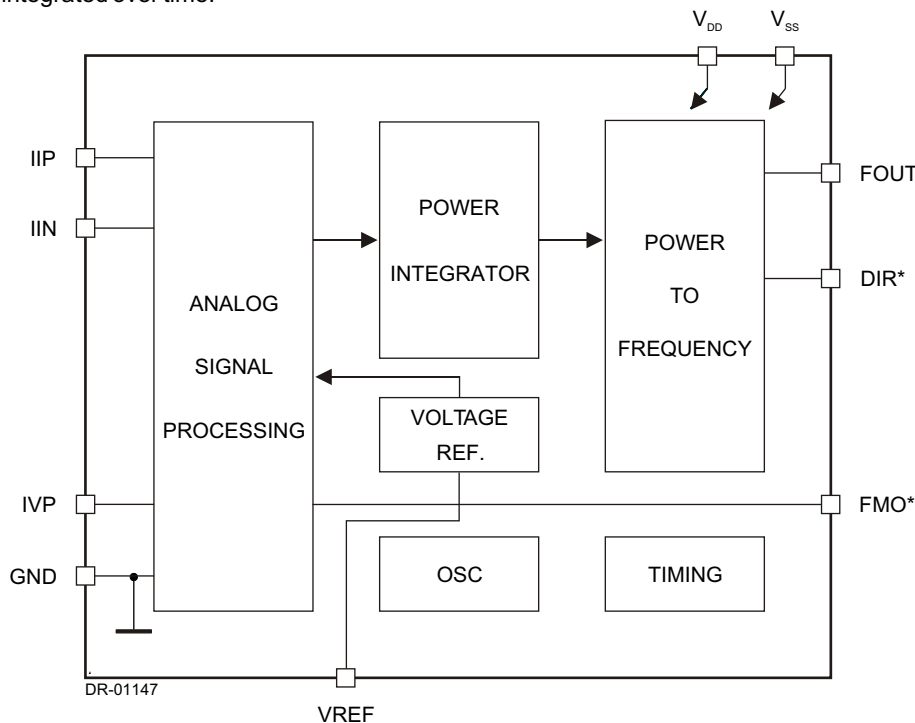

*FMO and DIR not available in DIP-8 package type

Figure 1: Block diagram

**ELECTRICAL CHARACTERISTICS**(V_{DD} = 2.5V, V_{SS} = -2.5V, over the temperature range -10°C to +70°C[#], unless otherwise specified.)

Parameter	Symbol	Min	Typ	Max	Unit	Condition
Operating temp. Range	T _O	-25		+85	°C	
Supply Voltage: Positive	V _{DD}	2.25		2.75	V	
Supply Voltage: Negative	V _{SS}	-2.75		-2.25	V	
Supply Current: Positive	I _{DD}		3	5	mA	
Supply Current: Negative	I _{SS}		3	5	mA	
Current Sensor Inputs (Differential)						
Input Current Range	I _{II}	-25		+25	µA	Peak value
Voltage Sensor Input (Asymmetrical)						
Input Current Range	I _{IV}	-25		+25	µA	Peak value
Pin FOUT, FMO, DIR Output High Voltage Output Low Voltage	V _{OL} V _{OH}	V _{DD} -1		V _{SS} +1	V V	
Pulse Rate FOUT	f _p	5 0	1360	1600 3000	Hz Hz Hz	At rated input conditions Specified linearity Min and Max frequency
Pulse Width FOUT	t _{pp} t _{pn}		71.55 143.1		µs µs	Positive energy flow Negative energy flow
Pin VREF Ref. Current Ref. Voltage	-I _R V _R	45 1.1	50	55 1.3	µA V	With R = 24k connected to V _{SS} Reference to V _{SS}

Extended Operating Temperature Range available on request.

ABSOLUTE MAXIMUM RATINGS*

Parameter	Symbol	Min	Max	Unit
Supply Voltage	V _{DD} -V _{SS}	-0.3	6.0	V
Current on any pin	I _{PIN}	-150	+150	mA
Storage Temperature	T _{STG}	-40	+125	°C
Operating Temperature	T _O	-25	+85	°C

*Stresses above those listed under "Absolute Maximum Ratings" may cause permanent damage to the device. This is a stress rating only. Functional operation of the device at these or any other condition above those indicated in the operational sections of this specification, is not implied. Exposure to Absolute Maximum Ratings for extended periods may affect device reliability.



PIN DESCRIPTION

8 Pin	14 Pin	16 Pin	20 Pin	Designation	Description
8	14	16	20	GND	Analog Ground. The voltage to this pin should be mid-way between V_{DD} and V_{SS} .
4	5	5	8	V_{DD}	Positive supply voltage. The voltage to this pin is typically +2.5V if a shunt resistor is used for current sensing or in the case of a current transformer a +5V supply can be applied.
6	10	9	14	V_{SS}	Negative supply voltage. The voltage to this pin is typically -2.5V if a shunt resistor is used for current sensing or in the case of a current transformer a 0V supply can be applied.
7	13	15	19	IVP	Analog Input for Voltage. The current into the A/D converter should be set at $14\mu A_{RMS}$ at nominal mains voltage. The voltage sense input saturates at an input current of $\pm 25\mu A$ peak.
1, 2	1, 2	1, 2	1, 2	IIN, IIP	Inputs for current sensor. The shunt resistor voltage from each channel is converted to a current of $16\mu A_{RMS}$ at rated conditions. The current sense input saturates at an input current of $\pm 25\mu A$ peak.
3	3	3	3	VREF	This pin provides the connection for the reference current setting resistor. A 24k resistor connected to V_{SS} set the optimum operating condition.
5	8	6	12	FOUT	Pulse rate output. Refer to pulse output format for a description of the pulse rate.
N.A.	9	7	13	DIR	Direction output. The direction of the energy flow is indicated on this output.
N.A.	11	11	15	FMO	Voltage sense zero crossover. The FMO output generates pulses on energy rising edge of the mains voltage.
	4	4	4	TP1	Leave pins unconnected.
	6	8	5	TP2	
	7	10	6	TP3	
	12	12	7	TP4	
		13	9	TP5	
		14	10	TP6	
			11	TP7	
			16	TP8	
			17	TP9	
			18	TP10	

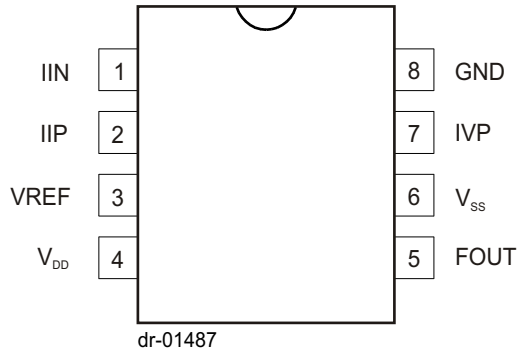

Figure 2: Pin connections: Package: DIP-8

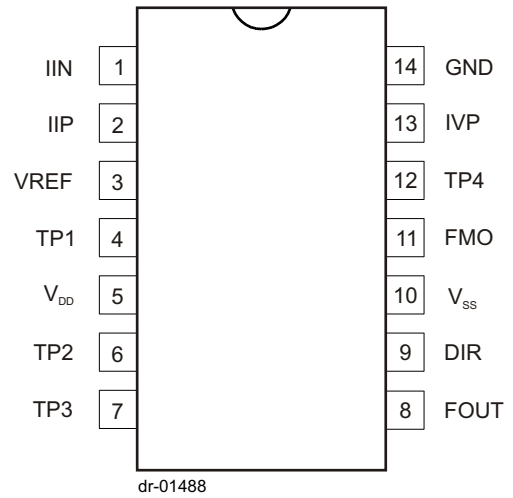

Figure 3: Pin connections: Package: DIP-14

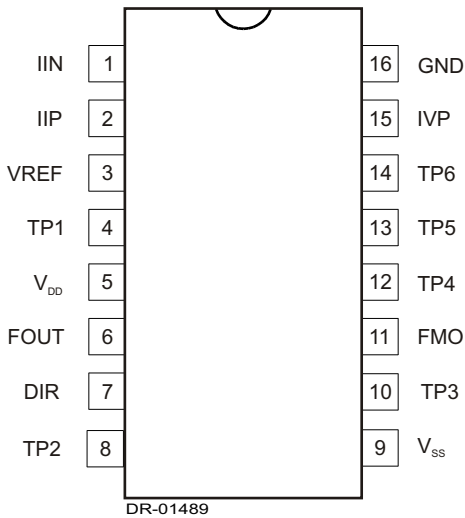

Figure 4: Pin connections: Package: SOIC-16

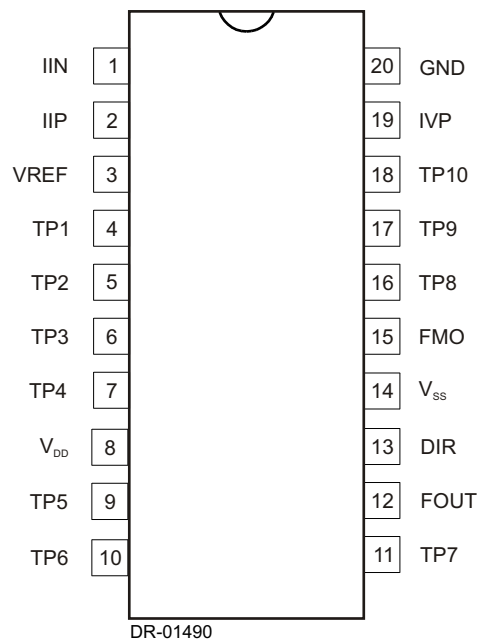

Figure 5: Pin connections: Package: DIP-20, SOIC-20

ORDERING INFORMATION

Part Number	Package
SA2002HPA	DIP-8
SA2002HPA	DIP-14
SA2002HPA	DIP-20
SA2002HSA	SOIC-16
SA2002HSA	SOIC-20



FUNCTIONAL DESCRIPTION

The SA2002H is a CMOS mixed signal Analog/Digital integrated circuit, which performs power/energy calculations across a power range of 1000:1, to an overall accuracy of better than Class 1.

The integrated circuit includes all the required functions for 1-phase power and energy measurement such as two oversampling A/D converters for the voltage and current sense inputs, power calculation and energy integration. Internal offsets are eliminated through the use of cancellation procedures. The SA2002H generates pulses, the frequency of which is proportional to the measured power consumption. One frequency output (FOUT) is available. The pulse rate follows the instantaneous power consumption measured.

POWER CALCULATION

In the application circuit (figure 6), the voltage drop across the shunt will be between 0 and 16mV_{RMS} (0 to 80A through a shunt resistor of 200μ) The voltage is converted to a current of between 0 and 16uA_{RMS}, by means of resistors R1 and R2. The current sense inputs saturates at an input current of ±25μA peak.

For the voltage sensor input, the mains voltage (230VAC) is divided down through a divider (R3, R4 and P1) to 14V_{RMS}. The current into the A/D converter input is set at 14μA_{RMS} at nominal mains voltage, via resistor R5 (1M). P1 may be varied for calibration purposes.

In this configuration, with a mains voltage of 230V and a current of 80A, the output frequency measured on the FOUT pin is 1360Hz. In this case one pulse on FOUT correspond to an energy consumption of 18.4kW/1360Hz = 13.53Ws.

ANALOG INPUT CONFIGURATION

The input circuitry of the current and voltage sensor inputs is illustrated in figure 7. These inputs are protected against electrostatic discharge through clamping diodes. The feedback loops from the outputs of the amplifiers A_I and A_V generate virtual shorts on the signal inputs. Exact duplications of the input currents are generated for the analog signal processing circuitry.

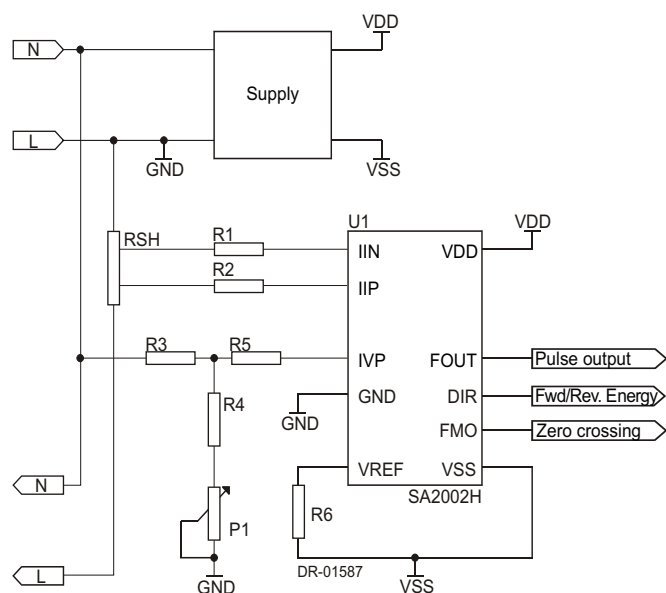
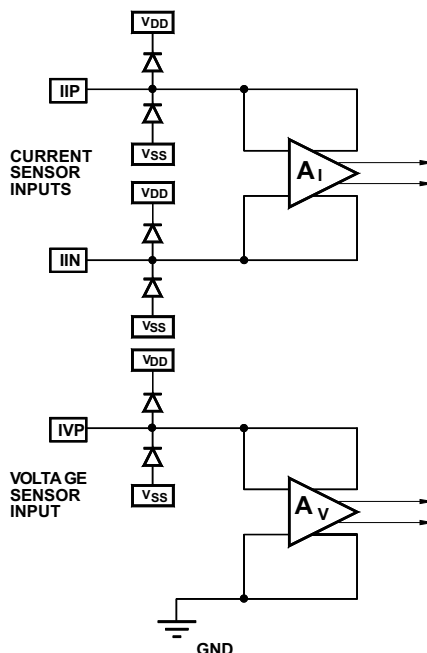

Figure 6: Application circuit



DR-01148

Figure 7: Internal analog input configuration



ELECTROSTATIC DISCHARGE (ESD) PROTECTION

The SA2002H integrated circuit's inputs/outputs are protected against ESD.

POWER CONSUMPTION

The power consumption rating of the SA2002H integrated circuit is less than 25mW.

INPUT SIGNALS

VREF

A bias resistor of 24k set optimum bias conditions on chip. Calibration of the SA2002H should be done on the voltage input as described in Typical Applications.

Current sense input (IIP and IIN)

Figure 6 shows the typical connections for the current sensor input. The resistor R1 and R2 define the current level into the current sense inputs of the SA2002H. At maximum rated current the resistor values should be selected for input currents of 16µA_{RMS}.

Values for resistors R1 and R2 can be calculated as follows:

$$R1 = R2 = (I_L / 16\mu A) \times RSH / 2$$

Where I_L = Line current

RSH = Shunt resistor or termination resistor if a CT is used as the current sensor.

The value of RSH, if used as the CT's termination resistor, should be less than the DC resistance of the CT's secondary winding. The voltage drop across RSH should not be less than 16mV_{RMS} at rated currents.

Voltage Sense Input (IVP)

The current into the A/D converter should be set at 14µA_{RMS} at nominal mains voltage. The voltage sense input saturates at an input current of ±25µA peak. Referring to figure 6 the typical connections for the voltage sense input is illustrated. Resistors R3, R4 and R5 set the current for the voltage sense input. The mains voltage is divided down to 14V_{RMS}. The current into the A/D converter input is set at 14µA_{RMS} via resistor R5.

OUTPUT SIGNALS

Pulse output (FOUT)

The output on FOUT is a pulse density signal representing the instantaneous power/energy measurement as shown in figure 8. The pulse width on FOUT changes with the direction of energy measurement by the device. The width of t_p is 71,5µs for positive energy and doubles if negative energy is measured. The output frequency may be calculated using the following formula:

$$f = 11.16 \times FOUT \times (I_L \times I_V) / I_R^2$$

Where:

FOUT = Typical rated output frequency (1360Hz)

I_L = Input current on current sense input (16µA at rated conditions)

I_V = Input current on voltage sense input (16µA at rated conditions)

I_R = Reference current on VREF typically 50µA

An integrated anti-creep function does not allow output pulses on FOUT if no power is measured by the device.

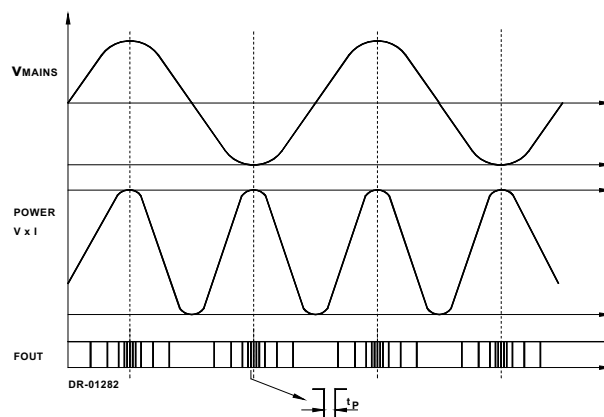

Figure 8: FOUT instantaneous pulse output



Direction indication (DIRO)

Note that the DIR output is not available in the DIP-8 package type. Figure 9 shows the behavior of DIR, when energy reversal takes place. The time period for the DIR signal to change state, t_{DIR} , is the time it takes for the internal integrator to count (down) from its present value to zero. Thus the energy consumption rate determines the speed of change on DIR.

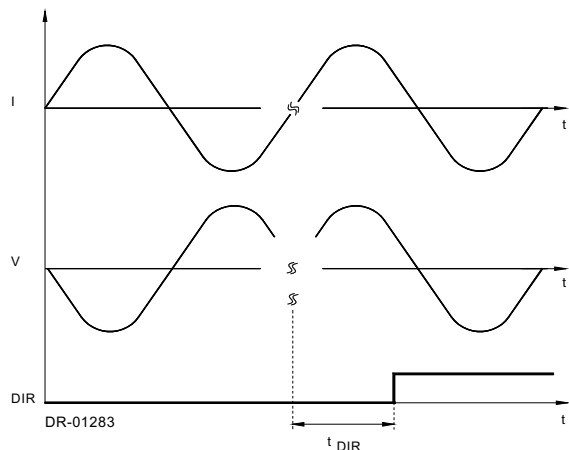

Figure 9: Measured energy direction on DIR

Mains zero crossing indication (FMO)

Note that the FMO output is not available in the DIP-8 package type. The square wave signal of FMO indicates the polarity of the mains voltage. Due to comparator offsets, the FMO low to high transition can occur within a range as shown in figure 10. The time between successive low to high transitions will be equal to the mains voltage period.

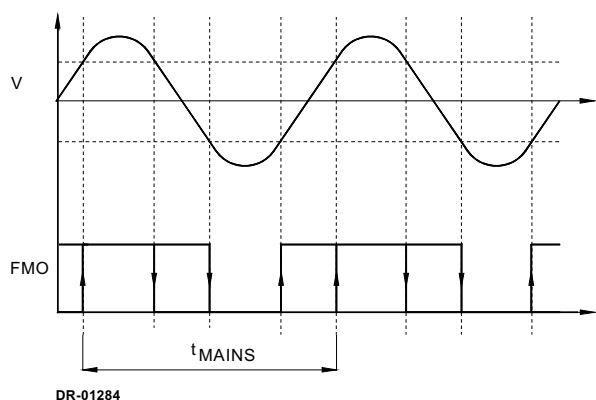

Figure 10: Mains zero crossings on FMO



TYPICAL APPLICATION

In figure 11, the components required for stand alone power metering application, is shown. The application uses a shunt resistor for the mains current sensing. The meter is designed for 220V/40A I_{MAX} operation. The most important external components for the SA2002H integrated circuit are the current sense resistors, the voltage sense resistors as well as the bias setting resistor.

BIAS RESISTOR

R13 defines all on-chip and reference currents. With R13=24k, optimum conditions are set. Device calibration is done on the voltage input of the device.

SHUNT RESISTOR

The voltage drop across the shunt resistor at rated current should be at least 20mV. A shunt resistor with a value of 625 μ is chosen. The voltage drop across the shunt resistor is 25mV at rated conditions (I_{max}). The power dissipation in the current sensor is:

$$P=(40A)^2 \times 625\mu = 1W.$$

CURRENT SENSE RESISTORS

The resistors R6 and R7 define the current level into the current sense inputs of the device. The resistor values are selected for an input current of 16 μ A on the current inputs of the SA2002H at rated conditions. According to equation described in the Current Sense inputs section:

$$\begin{aligned} R6 = R7 &= (I_i / 16\mu A) \times RSH / 2 \\ &= 40A / 16\mu A \times 625\mu / 2 \\ &= 781.2 \end{aligned}$$

A resistor with value of 820 is chosen, the 5% deviation from the calculated value will be compensated for when calculating resistor values for the voltage path.

VOLTAGE DIVIDER

The voltage divider is calculated for a voltage drop of 14V + 5%(14.7V). Equations for the voltage divider in figure 9 are:

$$\begin{aligned} RA &= R1 + R2 + R3 \\ RB &= R12 \parallel (R11 + P1) \end{aligned}$$

Combining the two equations gives:
(RA + RB) / 220V = RB / 14.7V

A 5k trimpot will be used in the voltage channel for meter calibration. The center position on the pot is used in the calculations. P1 = 2.5k and values for resistors R11 = 22k and R12=1M is chosen.

Substituting the values will result in:

$$\begin{aligned} RB &= 23.91k \\ RA &= RB \times (230V/14.7V - 1) = 333k \end{aligned}$$

so the resistor values of R1, R2 and R3 are chosen to be 110k

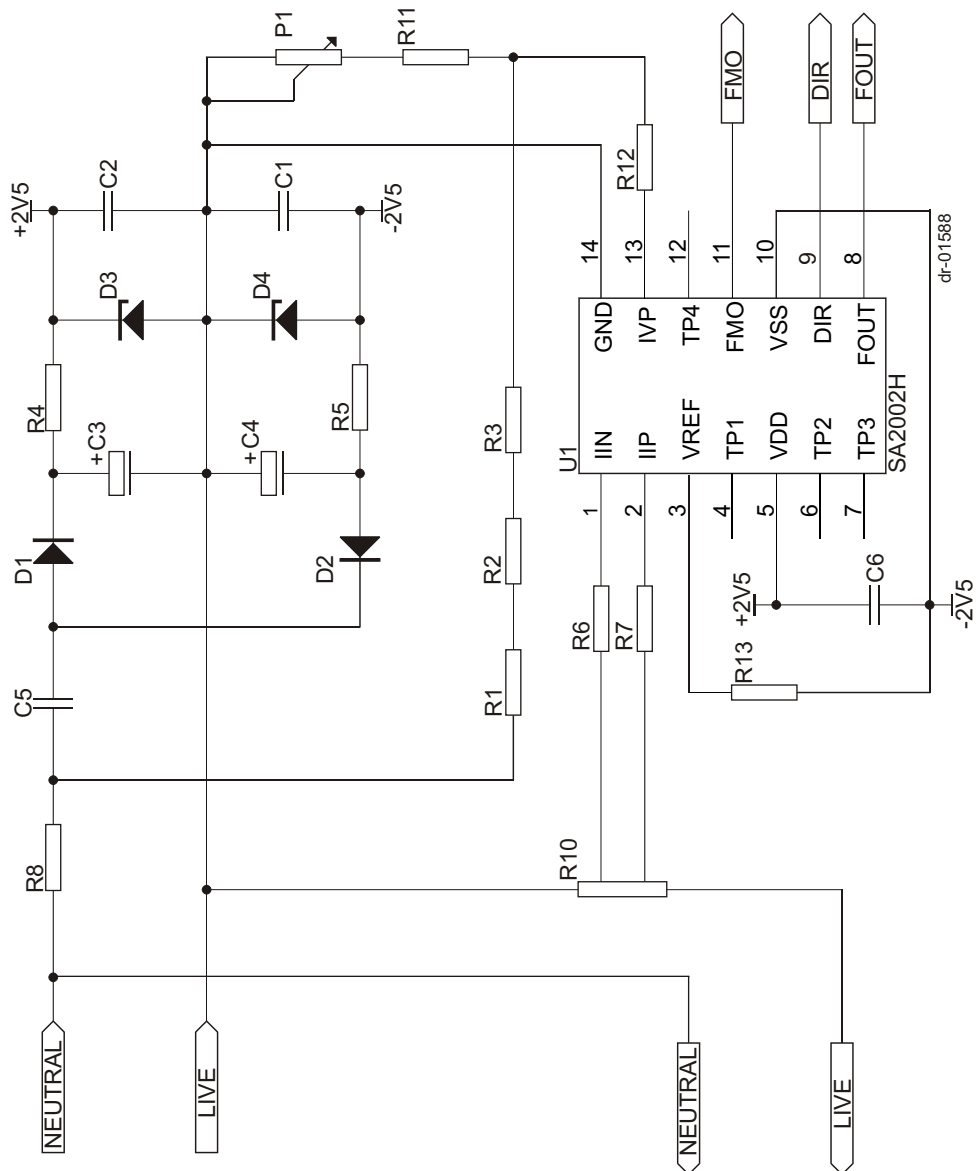

Figure 11: Application circuit using a shunt resistor for current sensing.

**Parts List for Application Circuit: Figure 10**

Symbol	Description	Detail
U1	SA2002H	DIP-14
D1	Diode, Silicon, 1N4002	
D2	Diode, Silicon, 1N4002	
D3	Diode, Zener, 2.4V	
D4	Diode, Zener, 2.4V	
R1	Resistor, 110k, 1/4W, 1% metal	
R2	Resistor, 110k, 1/4W, 1% metal	
R3	Resistor, 110k, 1/4W, 1%, metal	
R4	Resistor, 680, 1/4W, 1%, metal	
R5	Resistor, 680, 1/4W, 1%, metal	
R6	Resistor, 820, 1/4W, 1%, metal	Note 1
R7	Resistor, 820, 1/4W, 1%, metal	Note 1
R8	Resistor, 47R, 2W, 5%, wire wound	
R10	Shunt resistor	
R11	Resistor, 22k 1/4W, 1%, metal	
R12	Resistor, 1M, 1/4W, 1%, metal	
R13	Resistor, 24k, 1/4W, 1%, metal	
P1	Trim pot, 5k, Multi turn	
C1	Capacitor, 220nF	
C2	Capacitor, 220nF	
C3	Capacitor, 100uF, 16V, electrolytic	
C4	Capacitor, 100uF, 16V, electrolytic	
C5	Capacitor, 330nF, 250VAC	
C6	Capacitor, 820nF	Note 2

Note 1: Resistor (R6 and R7) values are dependant on the selected shunt resistor (R14) value.

Note 2: Capacitor C6 to be positioned as close as possible to supply pins.



NOTES:

**DISCLAIMER:**

The information contained in this document is confidential and proprietary to South African Micro-Electronic Systems (Pty) Ltd ("SAMES") and may not be copied or disclosed to a third party, in whole or in part, without the express written consent of SAMES. The information contained herein is current as of the date of publication; however, delivery of this document shall not under any circumstances create any implication that the information contained herein is correct as of any time subsequent to such date. SAMES does not undertake to inform any recipient of this document of any changes in the information contained herein, and SAMES expressly reserves the right to make changes in such information, without notification, even if such changes would render information contained herein inaccurate or incomplete. SAMES makes no representation or warranty that any circuit designed by reference to the information contained herein, will function without errors and as intended by the designer.

Any sales or technical questions may be posted to our e-mail address below:
energy@sames.co.za

For the latest updates on datasheets, please visit our web site:
<http://www.sames.co.za>

**SOUTH AFRICAN MICRO-ELECTRONIC SYSTEMS
DIVISION OF LABAT TECHNOLOGIES (PTY) LTD**

Tel: (012) 333-6021
Tel: Int +27 12 333-6021
Fax: (012) 333-8071
Fax: Int +27 12 333-8071

**P O BOX 15888
33 ELAND STREET
LYNN EAST 0039
REPUBLIC OF SOUTH AFRICA**

**33 ELAND STREET
KOEDOESPOORT INDUSTRIAL AREA
PRETORIA
REPUBLIC OF SOUTH AFRICA**