



ASM7306C/8406C □
DATA SHEET

6F-3 NO.7, LANE 75, TA-AN ROAD, SEC.1, TAIPEI, TAIWAN, R.O.C.
台北市大安路一段75巷7號6F-3 TEL:886-2-27818277 FAX:886-2-27815779

<http://www.aplusinc.com.tw>

ASM7306C/8406C

- VERY LOW-COST VOICE SYNTHESIZER WITH 4-BIT MICROPROCESSOR

1.0 General Description

The ASM7306C/8406C is very low cost voice synthesizer with 4-bit microprocessor. It has various features including 4-bit ALU, ROM, RAM, I/O ports, timers, clock generator, watchdog timer(WDT), voice synthesizer, etc . It consists of 22 instructions in the device. With CMOS technology and halt function can minimize power dissipation . Its architecture is similar cycle, to RISC, with two stages of instruction pipeline. It allows all instructions to be in a executed single except for program branches and data table read instructions (which need two instruction cycles).

1.1 Feature

- ◆ Single power supply can operate from 2.4V through 5.5V
- ◆ Internal Program ROM: 4K x 10-bit
- ◆ 1 sets of 18-bit DPR can access up to 256K x 10 bits data memory space
- ◆ Data Registers:
 - 64 x 4-bit data RAM (00-1Fh plus 40h-5Fh)
 - Unbanked special function registers (SFR) range: 20h-3Fh
- ◆ I/O Ports:
 - PRA: 4-bit I/O Port A (2Bh)
 - PRB: 2-bit Output Port B (2Dh)
- ◆ On-chip clock generator: Resistive Clock Drive(**RM**)
- ◆ Timer: 1
 - Timer0: a 9-bit auto-reload timer/counter
- ◆ Stack: 2-level subroutine nesting
- ◆ HALT and Release from HALT function to reduce power consumption
- ◆ Watch Dog Timer (**WDT**)
- ◆ Instruction: 1-cycle instruction except for table read and program branches which are 2-cycles
- ◆ Number of instruction: 22
- ◆ The Voice function can be implemented by microprocessor instruction
 - One 8-bit COUT output for ASM7306C/8406C

FIGURE 1.1 : Block Diagram of ASM8406C

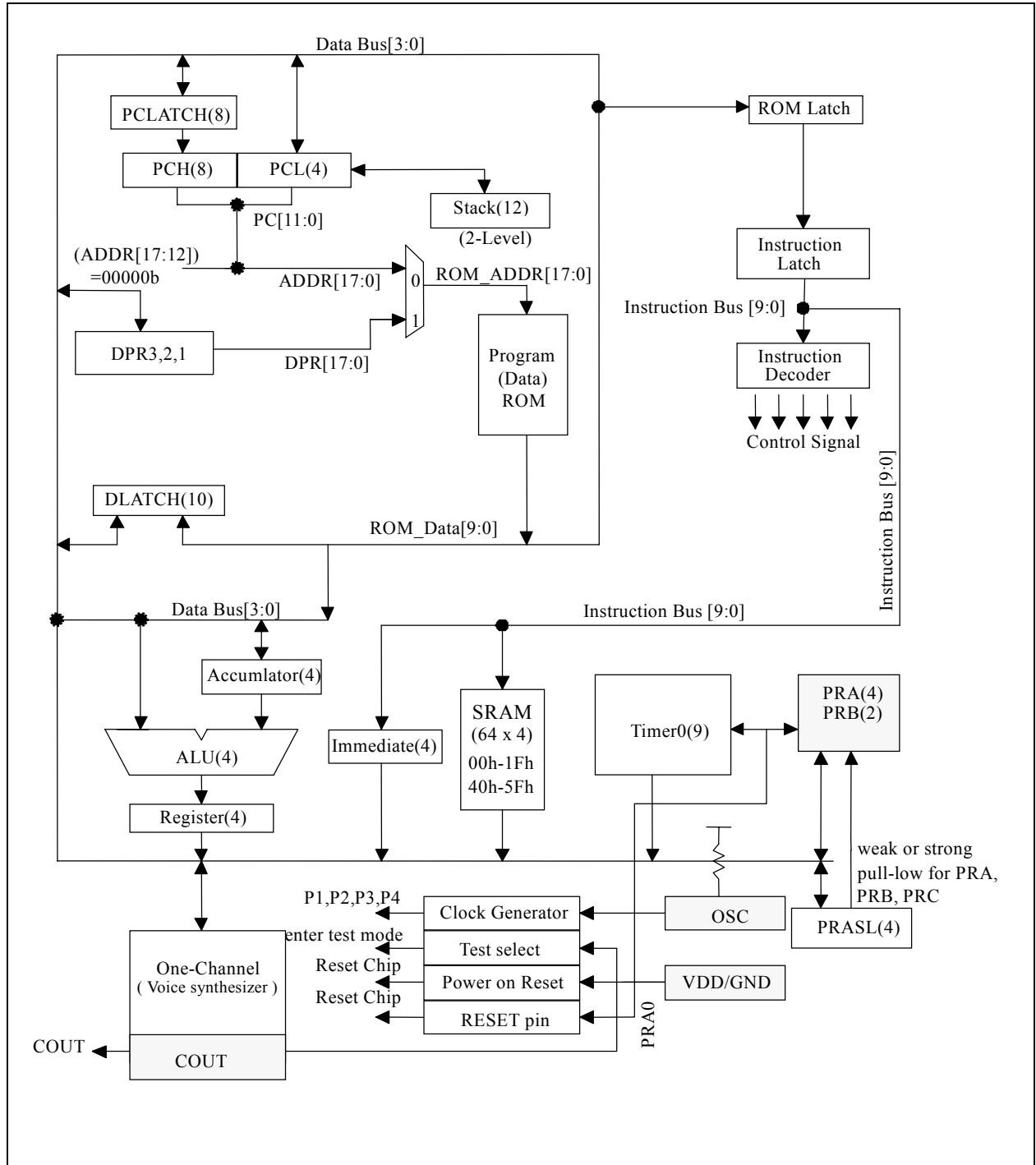
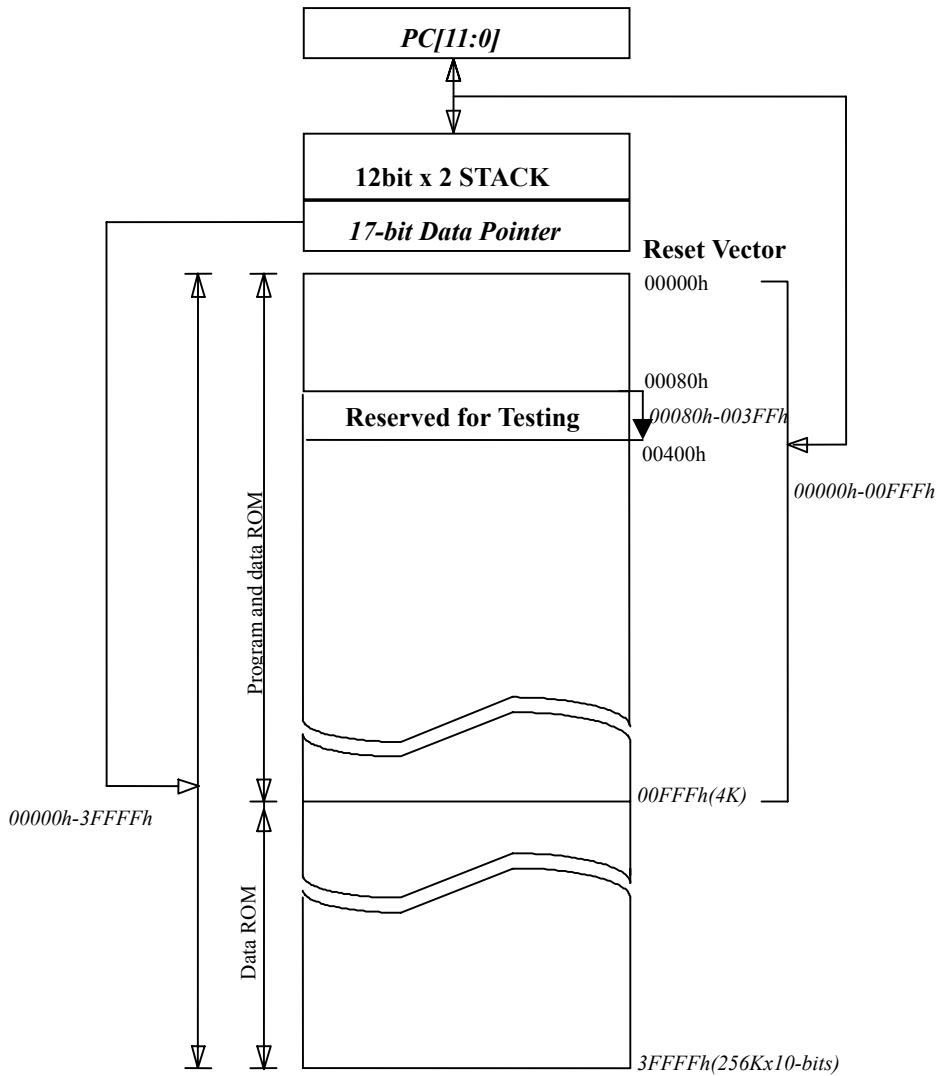

FIGURE 1.2 : External ROM Map of ASM7306C/8406C



1.2 Pin-Out

ASM7306C/8406C Pin-Out			
VDD	I	-	Power supply during operation
PRA3-1	I/O	STI Std./O.D.	I/O port with programmable strong pull-low or weak pull-low or fix-input-floating capability Output type with standard or Open-Drain output
PRA0/RESET	I/O	STI Std./O.D.	I/O port with programmable strong pull-low or weak pull-low or fix-input-floating capability Output type with standard or Open-Drain output <i>Mask option selected as an external RESET pin with weak pull-low capability</i>
OSC	I	-	RM mode Oscillator input
COUT	O	-	Current Output of Audio
GND	I	-	Circuit Ground Potential
TEST	O	-	Enter Test Mode. (TEST = High)
PRB0-1	O	Std./O.D.	Output type with standard or Open-Drain output

1.3 Application circuit

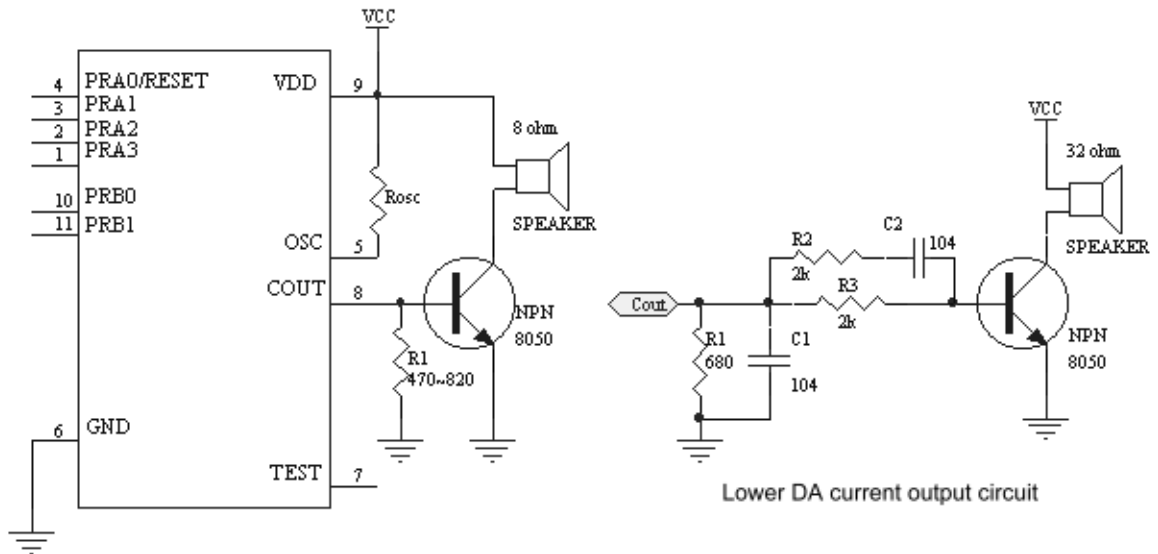

1.4 Bonding Diagram

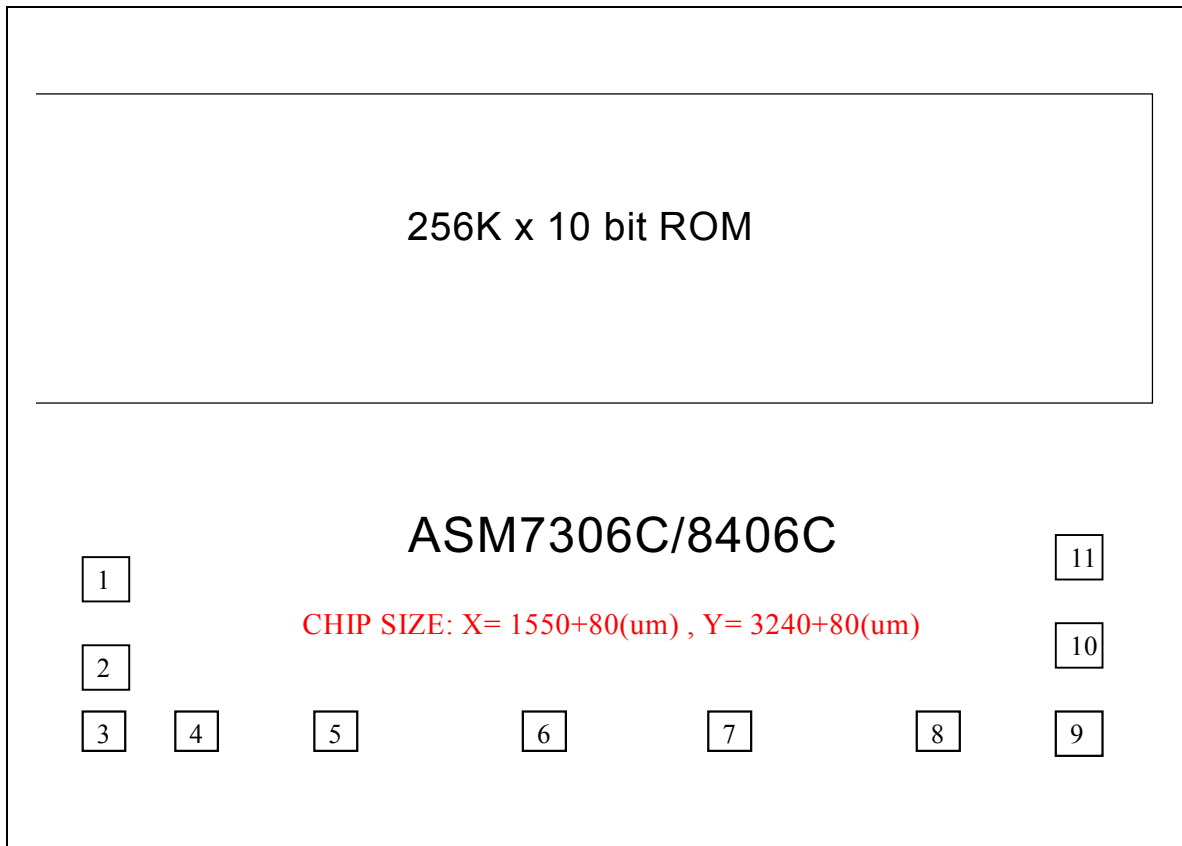

Substrate must be connected to GND.

ASM7306C/8406C Pad Location				CHIP SIZE: X= 1550+80(um) , Y= 3240+80(um)			
PAD #	PAD Name	X	Y	PAD #	PAD Name	X	Y
1	RA3	-664.92	-1211.84	7	TEST	105.44	-1536.52
2	RA2	-664.92	-1339.96	8	COUT	303.96	-1536.52
3	RA1	-662.64	-1536.52	9	VDD	683.04	-1536.52
4	RA0	-468.24	-1536.52	10	RB0	664.92	-1335.52
5	OSC	-281.04	-1536.52	11	RB1	664.92	-1217.12
6	GND	-111.72	-1536.52				

1.5 DC Characteristics for ASM7306C/8406C

SYMBOL	PARAMETER		VDD	MIN.	TYP.	MAX.	UNIT	CONDITION
VDD	OPERATING VOLTAGE			2.4	3	5.5	V	depending on Freq.
I _{sb}	SUPPLY CURRENT	STANDBY	3			1	uA	4MHz, RM in HALT Mode
			5			1		
I _{op}		OPERATING	3		2		mA	4MHz, RM IO Floating
			5		7			
I _{ih}	INPUT CURRENT /Internal pull low		3		3		uA	4MHz, RM in HALT Mode (IO Ports with weak pull-high pull-low)
			5		9			
			5		-5.2			
I _{oh}	OUTPUT HIGH CURRENT		3		-3		mA	4MHz, RM (IO ports)
			5		-8			
I _{ol}	OUTPUT LOW CURRENT		3		7		mA	4MHz, RM (IO ports)
			5		20			
C _{out}	DA CURRENT OUT (FULL SCALE)		3		4		mA	4MHz, RM (IO ports)
			5		5.2			
dF/F	FREQUENCY STABILITY			-10		10	%	F _{osc} (3v- 2.4v) F _{osc} (3v)
dF/F	F _{osc} VARIATION			-20		20	%	VDD=3V, R _{osc} =820k, 4MHz

FIGURE 1.3 : Frequency Range for R_{osc} in RM mode

Resistor(k ohm)	1400	1000	820	470
3v Freq.(MHz)	2.56	3.63	4.16	6.80

