



austriamicrosystems AG

is now

ams AG

The technical content of this austriamicrosystems application note is still valid.

Contact information:

Headquarters:

ams AG
Tobelbaderstrasse 30
8141 Unterpremstaetten, Austria
Tel: +43 (0) 3136 500 0
e-Mail: ams_sales@ams.com

Please visit our website at www.ams.com

1 General Overview

The AS5311 is a contactless high resolution magnetic linear encoder for accurate linear motion and off-axis rotary sensing with a resolution down to $<0.5\mu\text{m}$. It is a system-on-chip, combining integrated Hall elements, analog front end and digital signal processing on a single chip, packaged in a small 20-pin TSSOP package.

A multipole magnetic strip or ring with a pole length of 1.0mm is required to sense the rotational or linear motion. The magnetic strip is placed above the IC at a distance of typ. 0.3mm.

The absolute measurement provides instant indication of the magnet position within one pole pair with a resolution of 488nm per step (12-bit over 2.0mm). This digital data is available as a serial bit stream and as a PWM signal. Furthermore, an incremental output is available with a resolution of $1.95\mu\text{m}$ per step. An index pulse is generated once for every pole pair (once per 2.0mm). The travelling speed in incremental mode is up to 650mm/second. An internal voltage regulator allows the AS5311 to operate at either 3.3 V or 5 V supplies.

Depending on the application the AS5311 accepts multi-pole strip magnets as well as multi-pole ring magnets, both radial and axial magnetized.

2 The AS5311 Demoboard

The AS5311 demoboard is a complete linear encoder system with built-in microcontroller, USB interface, graphical LCD display, incremental indicators, incremental counter serial communication and PWM output LED.

The board is USB powered or externally supplied with a 9V battery for standalone operation.

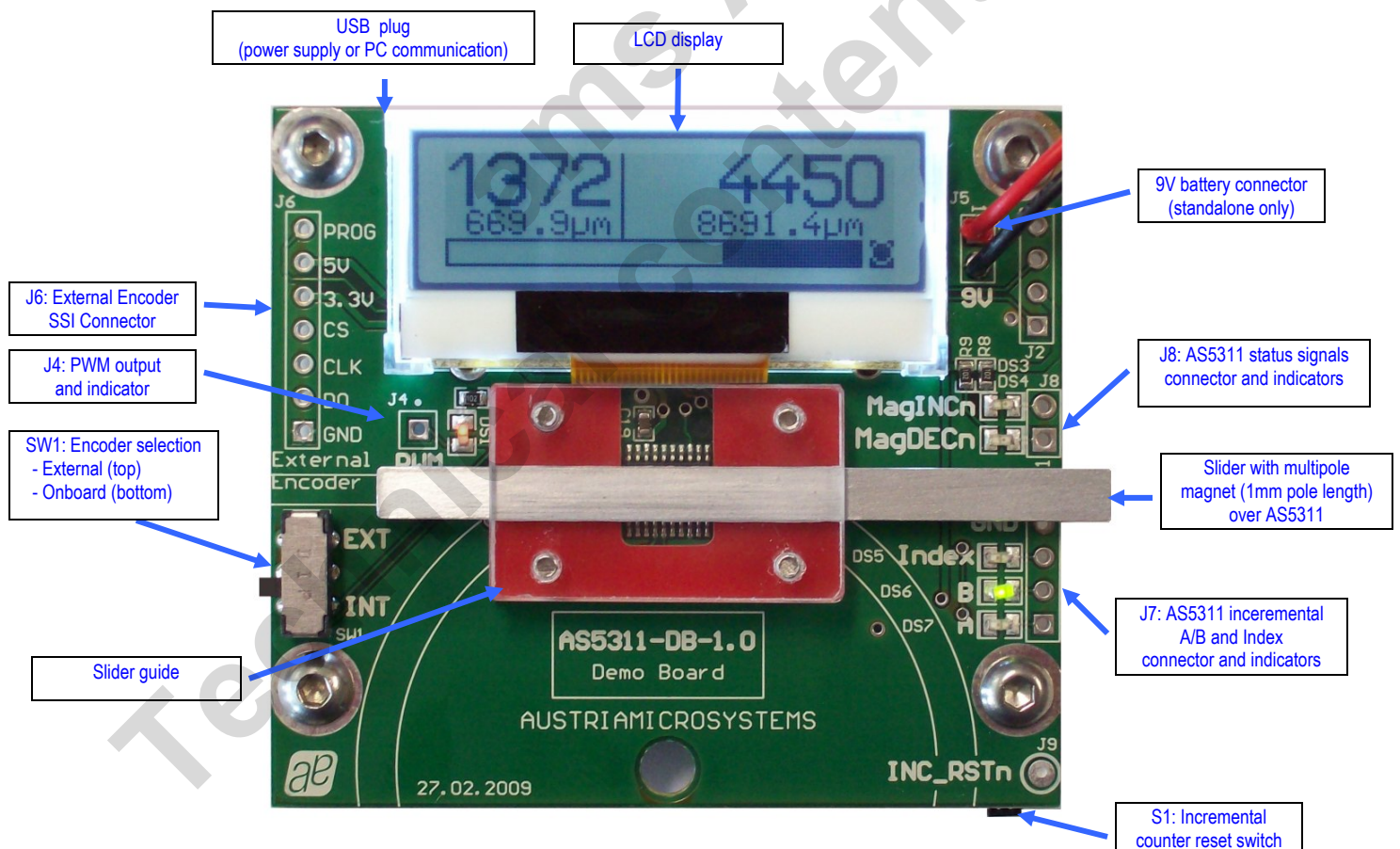

Figure 1: AS5311 Demoboard hardware with mounted magnet knob

3 Operating the AS5311 Demoboard

The AS5311 demoboard can be used in several ways:

- As standalone unit supplied by a 9V battery

Connect a 9V battery to the battery connector on the top right side of the board. No other connections are required.

- As standalone unit supplied by an USB port

Connect the demoboard to a PC using a USB/USB cable (included in demoboard shipment). The board is supplied by the 5V supply of the USB port. No other connections are required.

3.1 Hardware Indicators and Connectors

3.1.1 Graphic LCD display



The LCD display shows the realtime absolute and relative position of the magnet:

- The absolute position is read from the AS5311 serial output. The resolution is $0.488\mu\text{m} = 4096$ positions per pole pair (2mm). To use this feature with the onboard encoder, switch SW1 must be on position INT.

- The relative position is read from the incremental counter connected on the AB outputs of the AS5311. The resolution is $1.95\mu\text{m} / \text{step}$. To use this feature with the onboard encoder, jumpers P1 and P2 (Bottom side) must be CLOSED.

Moving the slider from right to left will increase the absolute value until 4095 ($1999\mu\text{m}$) with $0.488\mu\text{m}$ steps, then returns to 0.

The incremental counter will increment on the same way with $1.95\mu\text{m}$ steps. To reset the relative position, press the push button S1.

The magnet status indicator  (magnet OK),  (magnet too close or too far, reduced accuracy),  (magnet too close or too far, values not valid and display stopped) is related to the magnet position.

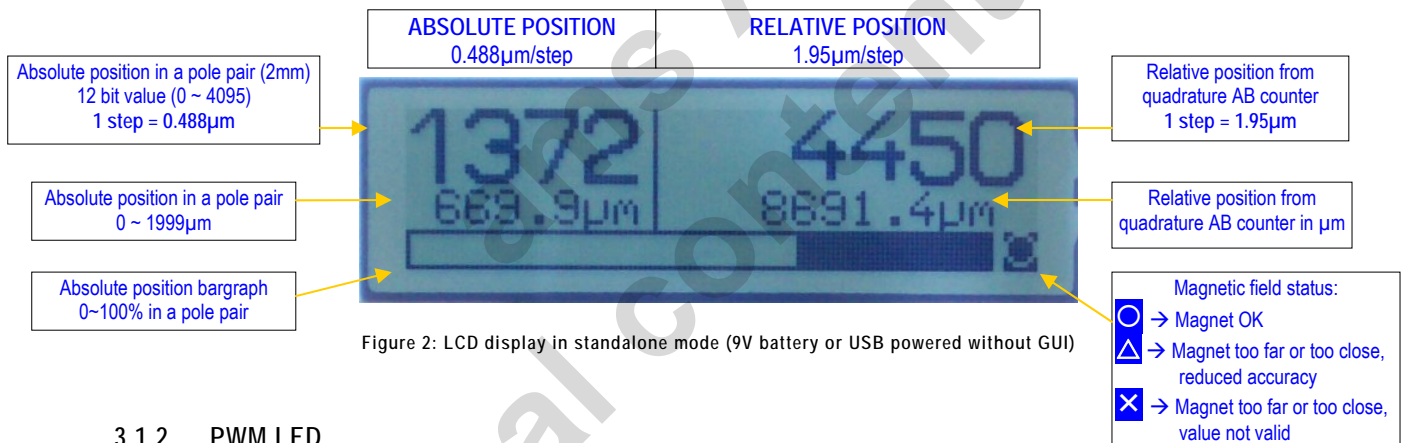

3.1.2 PWM LED

This LED is connected to the PWM output of the AS5311. The PWM output is a pulse width that is proportional to the position of a pole-pair of the magnet

The pulse width varies from $1\mu\text{s}$ to $4096\mu\text{s}$ typ with a repetition rate of 244 Hz typ.. When the position of the pole-pair is 0, the LED is almost dark, as it is $1\mu\text{s}$ on and $4095\mu\text{s}$ off. Moving the magnet to the left increases the brightness of the PWM LED, since the ON-pulse becomes longer and the OFF-pulse becomes shorter. The brightness of the PWM LED follows the absolute position bargraph.

Likewise, the PWM output can be used as an analog output proportional to the angle, when the PWM signal is filtered by a RC (or active) lowpass filter.

The PWM signal (0 ~ 3V3) can be directly taken from the connector J4.

3.1.3 Incremental quadrature AB-Index LED

The phase shift between channel A and B indicates the direction of the magnet movement. Channel A leads channel B during a right-to-left movement of the magnet by 90 electrical degrees. Channel B leads channel A during a left-to-right movement.



One Index pulse (3V3) is generated at each pole pair changes (see AS5311 datasheet Figure 9).

The AB-Index LEDs are directly connected to the A B Index outputs of the AS5311. These quadrature signals (0 ~ 3V3) are available on connector J7.

3.1.4 MagINCn and MagDECn

MagINCn and MagDECn are the magnetic field change indicators (magnetic field strength increase or decrease through variation of the distance between the magnet and the device).

These outputs can be used to detect the valid magnetic field range.

- LEDs MagINC and MagDEC OFF, the magnet is correctly positioned
→ LCD indicator 
- LED MagINC ON and MagDEC OFF, magnet too close or too far, reduced accuracy
→ LCD indicator 
- LEDs MagINC and MagDEC ON, magnet too close or too far, values not valid and display stopped →
LCD indicator 

3.1.5 Encoder selection switch

The switch SW1 selects the encoder which communicates with the microcontroller through the SSI bus (Absolute position):

1. INT (Bottom position, default): Onboard AS5311
2. EXT (Top Position): External AS5311 connected on J6
The signals of the synchronous serial interface (DO, CLK, CSn) and the power supply (3.3V, GND) of an external device can be connected directly to J6. In this configuration, the data of the serial interface (absolute position) are displayed on the GUI or the LCD.

If the incremental AB position of the external encoder is used, remove the jumpers P1 and P2 (bottom side of the board), and connect the AB signals from the encoder to the jumpers as shown on figure 3 below.

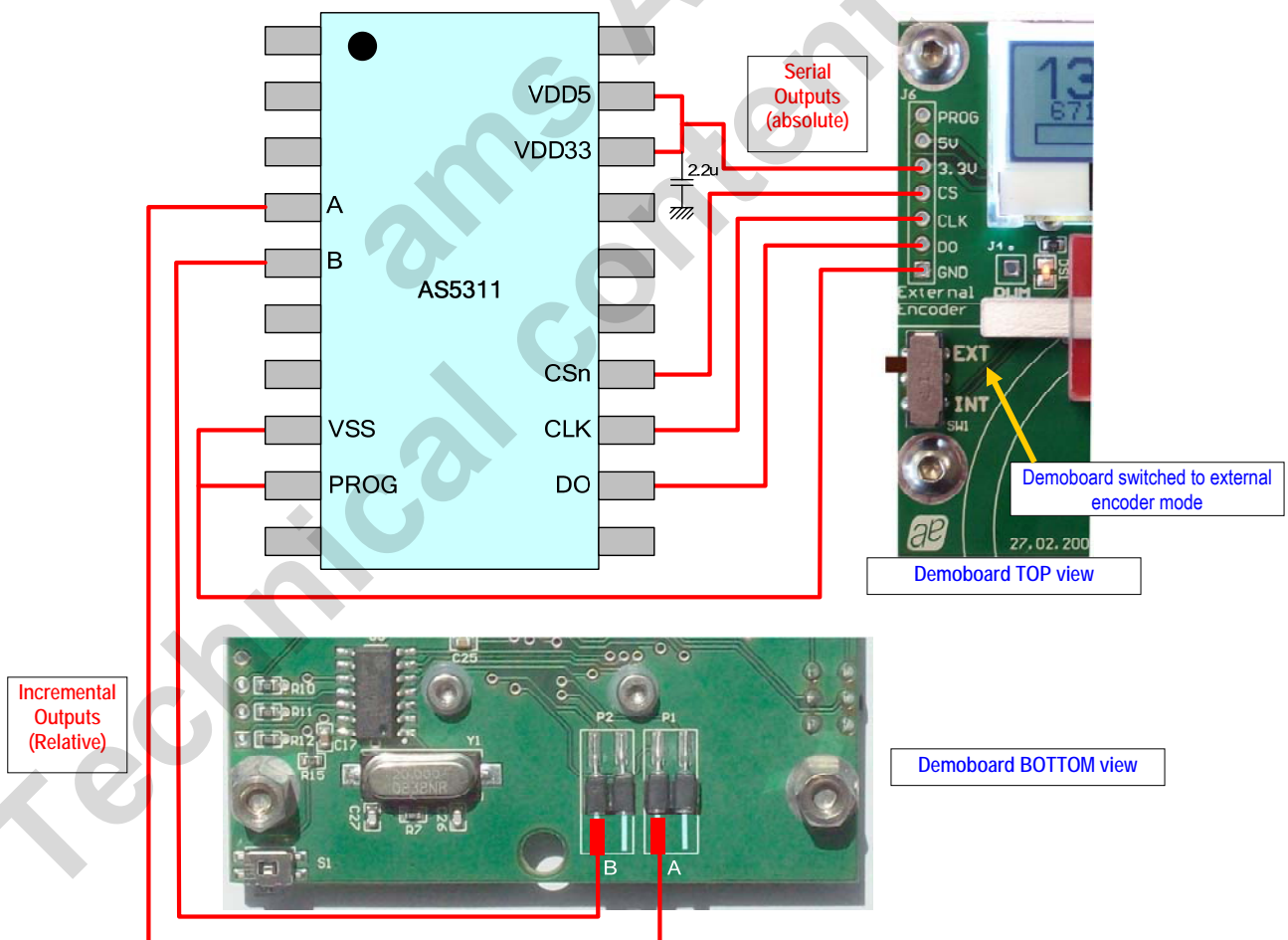

Figure 3: external AS5311 connection to the demoboard (top and bottom view)

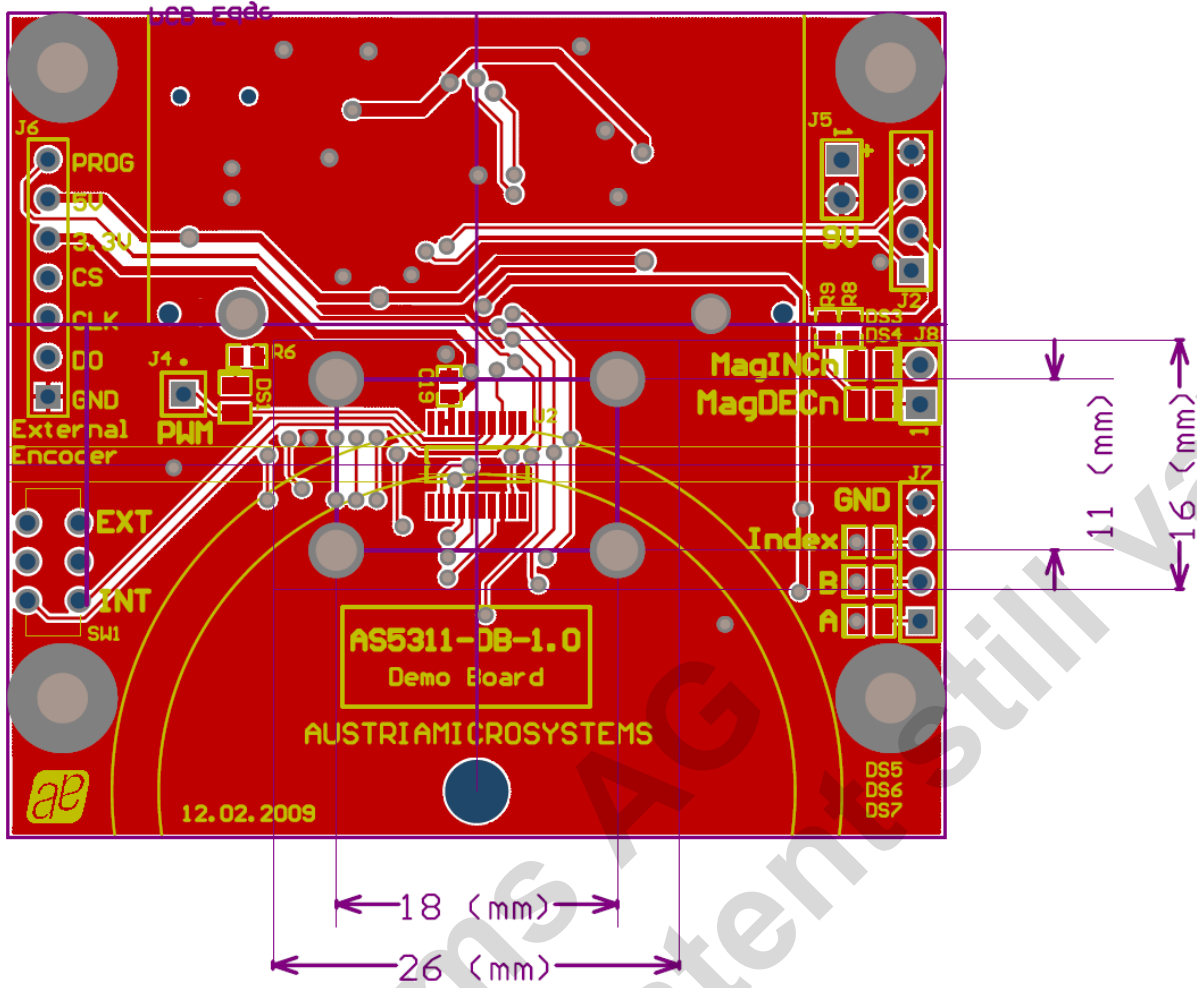

Figure 4: AS5311 Demoboard PCB Layout

Index

1	General Overview	1
2	The AS5311 Demoboard	1
3	Operating the AS5311 Demoboard	2
3.1	Hardware Indicators and Connectors	2
3.1.1	Graphic LCD display	2
3.1.2	PWM LED	2
3.1.3	Incremental quadrature AB-Index LED	2
3.1.4	MagINCn and MagDECn	3
3.1.5	Encoder selection switch	3
4	AS5311 Demoboard bloc diagram, schematics, layout	4
	Index	6
	Revision History	7
	Contact	8
	Copyright	9

Revision History

Revision	Date	Description
R1.0	March.16, 2009	First version

ams AG
Technical content still valid

Contact

Headquarters

austriamicrosystems AG
 A 8141 Schloss Premstätten, Austria
 Phone: +43 3136 500 0
 Fax: +43 3136 525 01
industry.medical@austriamicrosystems.com
www.austriamicrosystems.com

Sales Offices

austriamicrosystems Germany GmbH
 Tegernseer Landstrasse 85
 D-81539 München, Germany
 Phone: +49 89 69 36 43 0
 Fax: +49 89 69 36 43 66

austriamicrosystems Italy S.r.l.
 Via A. Volta, 18
 I-20094 Corsico (MI), Italy
 Phone: +39 02 4586 4364
 Fax: +39 02 4585 773

austriamicrosystems France S.A.R.L.
 124, Avenue de Paris
 F-94300 Vincennes, France
 Phone: +33 1 43 74 00 90
 Fax: +33 1 43 74 20 98

austriamicrosystems Switzerland AG
 Rietstrasse 4
 CH 8640 Rapperswil, Switzerland
 Phone: +41 55 220 9008
 Fax: +41 55 220 9001

austriamicrosystems UK, Ltd.
 88, Barkham Ride,
 Finchampstead, Wokingham
 Berkshire RG40 4ET, United Kingdom
 Phone: +44 118 973 1797
 Fax: +44 118 973 5117

austriamicrosystems AG
 Klaavuntie 9 G 55
 FI 00910 Helsinki, Finland
 Phone: +358 9 72688 170
 Fax: +358 9 72688 171

austriamicrosystems AG
 Bivägen 3B
 S 19163 Sollentuna, Sweden
 Phone: +46 8 6231 710

austriamicrosystems USA, Inc.
 8601 Six Forks Road
 Suite 400
 Raleigh, NC 27615, USA
 Phone: +1 919 676 5292
 Fax: +1 509 696 2713

austriamicrosystems USA, Inc.
 4030 Moorpark Ave
 Suite 116
 San Jose, CA 95117, USA
 Phone: +1 408 345 1790
 Fax: +1 509 696 2713

austriamicrosystems AG
 Suite 811, Tsimshatsui Centre
 East Wing, 66 Mody Road
 Tsim Sha Tsui East, Kowloon, Hong Kong
 Phone: +852 2268 6899
 Fax: +852 2268 6799

austriamicrosystems AG
 AIOS Gotanda Annex 5th Fl., 1-7-11,
 Higashi-Gotanda, Shinagawa-ku
 Tokyo 141-0022, Japan
 Phone: +81 3 5792 4975
 Fax: +81 3 5792 4976

austriamicrosystems AG
 #805, Dong Kyung Bldg.,
 824-19, Yeok Sam Dong,
 Kang Nam Gu, Seoul
 Korea 135-080
 Phone: +82 2 557 8776
 Fax: +82 2 569 9823

austriamicrosystems AG
 Singapore Representative Office
 83 Clemenceau Avenue, #02-01 UE Square
 239920, Singapore
 Phone: +65 68 30 83 05
 Fax: +65 62 34 31 20

Copyright

Devices sold by austriamicrosystems are covered by the warranty and patent indemnification provisions appearing in its Term of Sale. austriamicrosystems makes no warranty, express, statutory, implied, or by description regarding the information set forth herein or regarding the freedom of the described devices from patent infringement. austriamicrosystems reserves the right to change specifications and prices at any time and without notice. Therefore, prior to designing this product into a system, it is necessary to check with austriamicrosystems for current information. This product is intended for use in normal commercial applications.

Copyright © 2009 austriamicrosystems. Trademarks registered ®. All rights reserved. The material herein may not be reproduced, adapted, merged, translated, stored, or used without the prior written consent of the copyright owner. To the best of its knowledge, austriamicrosystems asserts that the information contained in this publication is accurate and correct. However, austriamicrosystems shall not be liable to recipient or any third party for any damages, including but not limited to personal injury, property damage, loss of profits, loss of use, interruption of business or indirect, special, incidental or consequential damages, of any kind, in connection with or arising out of the furnishing, performance or use of the technical data herein. No obligation or liability to recipient or any third party shall arise or flow out of austriamicrosystems rendering of technical or other services.

Mouser Electronics

Authorized Distributor

Click to View Pricing, Inventory, Delivery & Lifecycle Information:

[ams:](#)

[AS5311-DB](#)