

CHARACTERISTICS

PARAMETER	MIN	TYP	MAX	UNITS	CONDITIONS/REMARKS
SUPPLY VOLTAGE	5.4	8.0	13.2	VOLTS	-25°C TO 85°C
SUPPLY CURRENT		13	20	mA	MAX @ -25°C, TYP @ 25°C, V _s =8.0V, EXCLUDES LOAD
OUTPUT CURRENT	1			mA	SINKING OR SOURCING
OUTPUT VOLTAGE SWING (-V)+1.25			(+V)-1.25	VOLTS	MAX CLAMPED @ 9.0 VOLTS MIN
SENSITIVITY	23.4		27.7	mV/NI	@ V _s =8.0V & 25°C Δ 5
LINEARITY		.5	1.0	% OF SPAN	DEV FROM STR LINE FROM -I MAX TO +I MAX Δ 1
V _{out} @ \emptyset NULL	.5(V _s)-2%		.5(V _s)+2%	VOLTS	25°C
TEMP ERROR-NUL	-.02		+.02	%/°C	-25°C TO 85°C
TEMP ERROR-GAIN	-.06		+.01	5%/°C	-25°C TO 85°C

M CSLA2DE

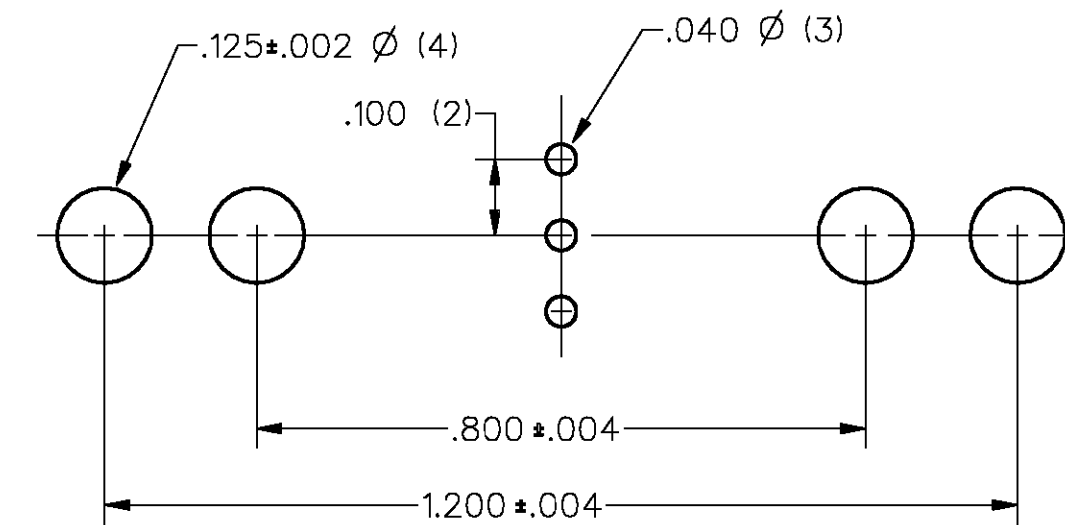

SUGGESTED HOLE CENTERS
SCALE 4:1

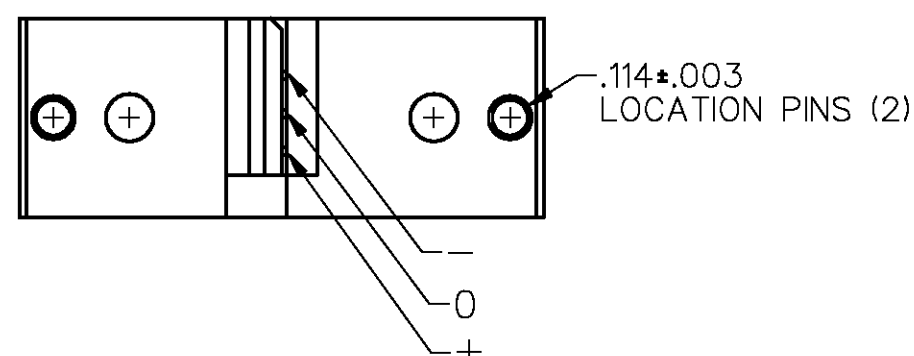
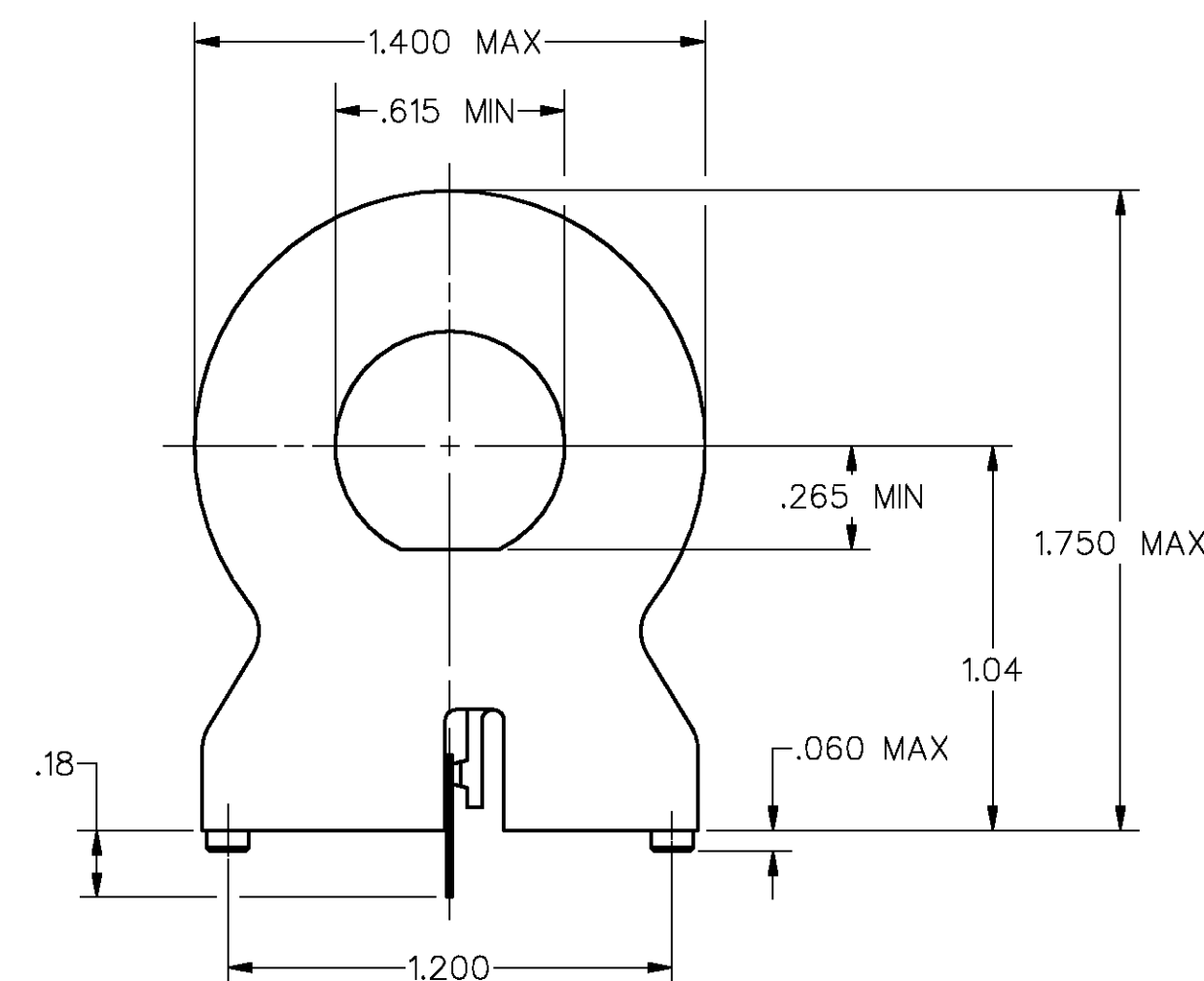
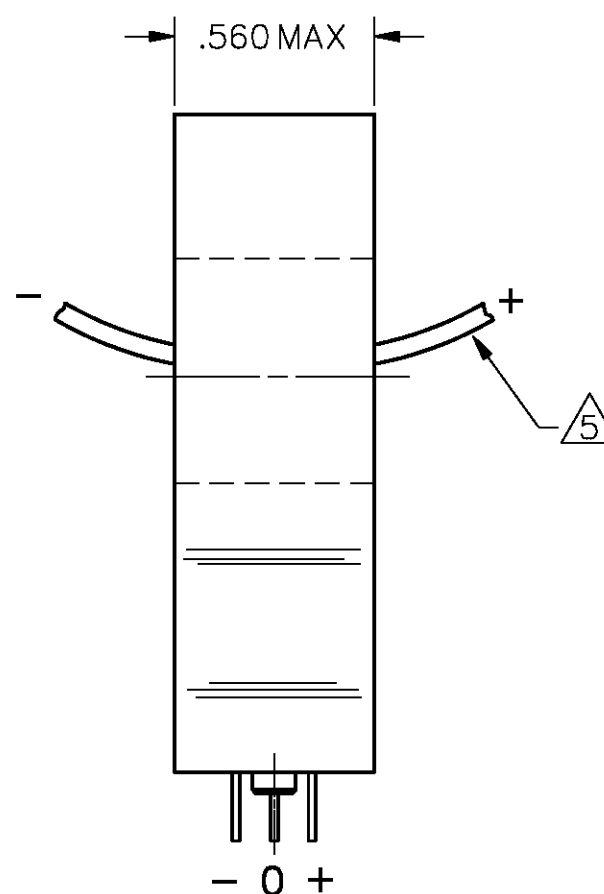
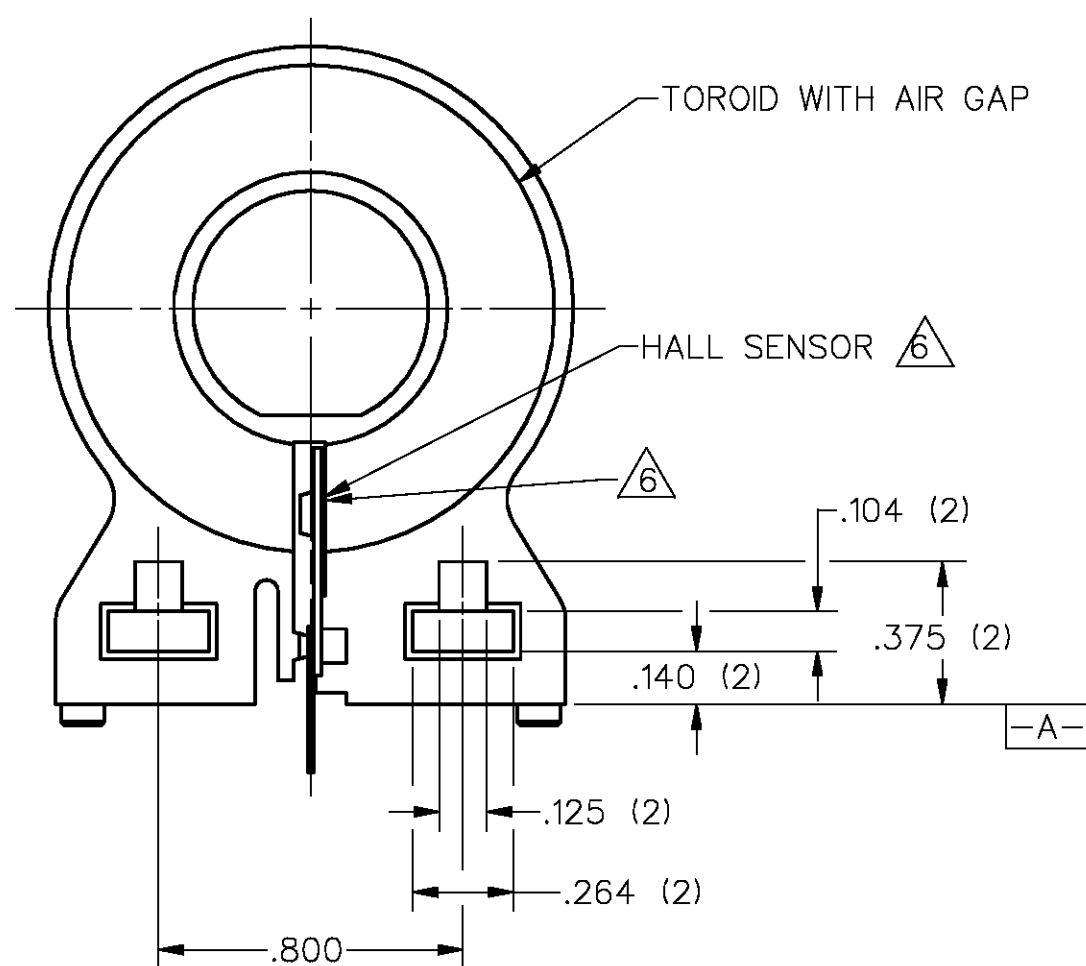

NOTES

- 1 SUGGESTED I MAX FOR LINEAR OPERATION IS 92 AMPS
- 2 - RECOMMENDED MOUNTING IS 4-40 SQUARE NUT AND .375 LONG 4-40 SCREW
- 3 - CONVENTIONAL CURRENT FLOW IN DIRECTION INDICATED WILL CAUSE AN INCREASE IN OUTPUT VOLTAGE
- 4 - THE DEVICE CANNOT BE DAMAGED BY MAGNETIC OVERDRIVE
- 5 AT V_s OTHER THAN 8.0 VOLTS, SENSITIVITY = (NUMBER SHOWN) X V_s/8
- 6 BACKSIDE OF HALL SENSOR IS ELECTRICALLY CONNECTED TO THE "-" TERMINAL

DRAWING NUMBER: CSLA2DE
 ISSUE: 4
 PAGE 1 OF 1
 RELEASE NO. DR-3141-8 REPLACES X83399-CS
 REVISIONS:
 A CO 65790
 B CO 79248B
 C CO 95704
 FORMTEK DRAWN
 JAS 18JUL89 CHECK K A G 19JUL89
 MASTER REDUCED



THIS DRAWING COVERS A PROPRIETARY ITEM AND IS THE PROPERTY OF MICRO SWITCH, A DIVISION OF HONEYWELL. THIS DRAWING IS NOT TO BE COPIED OR USED WITHOUT THE APPROVAL OF MICRO SWITCH.

MICRO SWITCH
a Honeywell Division

CURRENT SENSOR

CATALOG LISTING
CSLA2DE

FED. MFG. CODE 91929

THIRD ANGLE PROJECTION	
SCALE	2:1
DO NOT SCALE PRINT	
UNLESS OTHERWISE SPECIFIED TOLERANCES ARE	
ONE PLACE	(.0) ±.030
TWO PLACES	(.00) ±.015
THREE PLACES	(.000) ±.005
ANGLES	±
WEIGHT	