



**AEM, INC.**

11525 Sorrento Valley Rd.  
San Diego, California 92121  
(858) 481- 0210

SPECIFICATION SHEET

**P700L CURRENT LIMITING FUSE**

**SURFACE MOUNT MODEL**

|           |                                   |      |      |       |      |               |      |      |      |  |
|-----------|-----------------------------------|------|------|-------|------|---------------|------|------|------|--|
| REVISION: | A                                 | B    | C    | D     | E    | F             | G    | H    | J    |  |
| DATE:     | 10/95                             | 2/96 | 2/00 | 10/95 | 2/96 | 10/98         | 4/00 | 3/01 | 3/04 |  |
| DRAWN:    | Jeff Montgomery                   |      |      |       |      |               |      |      |      |  |
| CHECKED:  | Mike Van Linge / P.<br>Aguimatang |      |      |       |      |               |      |      |      |  |
| APPROVED: | Jeff Montgomery                   |      |      |       |      |               |      |      |      |  |
| ECN:      | 2139                              |      |      |       |      | SHEET 1 OF 23 |      |      |      |  |

1. SCOPE

1.1 Scope. This specification establishes the requirements for thick film current limiting fuses. Fuses described in this document are designed and manufactured for high reliability applications based on guaranteed blow limits. These fuses are intended for use in direct (DC) and alternating current (AC) circuits and are capable of operation over a temperature range of -55°C to +125°C ambient including high vacuum environments.

2. LOT ACCEPTANCE TESTING

2.1 Lot Acceptance Testing. This specification provides for two acceptance levels for the procurement of the fuses. The degree of testing and associated documentation can be specified as appropriate to the end use of the fuses. Regardless of the acceptance level specified, the inherent quality and reliability of the fuses will remain constant. The acceptance levels with the applicable inspection required are indicated in Table I.

**TABLE I. LOT ACCEPTANCE LEVEL.**

| LOT ACCEPTANCE LEVEL | INSPECTION TO BE PERFORMED |         |         |
|----------------------|----------------------------|---------|---------|
|                      | GROUP A                    | GROUP B | GROUP C |
| LAT 2                | X                          | X       |         |
| LAT 1                | X                          | X       | X       |

3. APPLICABLE DOCUMENTS

3.1 Issues of Documents. The following specifications, standards and handbooks form a part of this specification to the extent specified herein. In the event of a conflict between the documents referenced herein and this specification, this specification governs.

SPECIFICATIONS

MIL-PRF-23419: General Specification for Instrument Type Fuses.

MIL-F-14256: Flux, Soldering, Liquid (Rosin Base).

STANDARDS

MIL-STD-202: Test Methods for Electronic and Electrical Component Parts.

MIL-STD-790: Reliability Assurance Program for Electronic Parts Specifications.

MIL-STD-1285: Marking of Electrical and Electronic Parts.

MIL-STD-45662: Calibration System Requirements.

|              |   |                              |               |
|--------------|---|------------------------------|---------------|
| AEM, Inc.    | 11525 SORRENTO VALLEY RD<br>SAN DIEGO, CA 92121-1306. | TITLE<br>P700L SPECIFICATION |               |
| NUMBER P700L | REVISION J  | ECN 2139                     | SHEET 2 of 23 |

## OTHERS

P700L-PA: Internal Visual Examination (Precap) for Current Limiting Fuses.

P700L-R: Radiographic Inspection for Current Limiting Fuses.

ASTM E595: Materials from Outgassing in a Vacuum Environment, Total Mass Loss and Collected Volatile Condensable, Standard Test Method for.

## 4. REQUIREMENTS

4.1 Qualification. Fuses manufactured in accordance with this document shall be capable of passing the qualification requirements specified in Table V and section 4 of this document.

4.2 Materials, Design and Construction. The materials, design and construction of the fuses shall be as specified herein (see Figure 5 for flow chart of operations).

4.2.1 Terminals. The lead material shall be copper, electro tin-lead plated per MIL-P-81728 or solder coated with Sn60 / Pb40 solder. Exposed base material may be present but shall not exceed 2% of the total lead surface.

4.2.2 Housing. The housing material shall be polyphenylene sulfide (PPS). The PPS material shall be insert molded to form the body of the fuse.

4.3 Voltage Rating. The voltage ratings for fuses specified herein are 50, 72 and 125 volts DC.

4.4 Current Rating. The current rating is the maximum amperes that the fuse will carry at a case temperature of +25°C without degradation. The applicable current ratings are specified in Table VI.

4.5 Temperature Rating. The temperature rating for fuses specified herein is -55°C to +150°C nonoperating. The maximum operating temperature shall not exceed a case temperature of +125°C. The temperature derating curve is given in Figure 4.

4.6 Resistance Rating. The cold resistance of the fuses shall be as specified in Table VI when measured in accordance with 5.8.2.

4.7 Marking. Fuses shall be marked in accordance with Method I of MIL-STD-1285. The following information shall be marked on each fuse:

- a) AEM Part Number (see Table VI)
- b) Manufacture lot code (C-Lot)

Note: For marking examples, please refer to Figures 1 and 2.

4.8 Performance.

4.8.1 Thermal Shock (Group A and Group B). When fuses are tested in accordance with 5.8.3 herein, they shall show no electrical or mechanical damage and there shall be no loosening of the terminals. Their cold resistance shall not change by more than 10 percent from the pre-thermally shocked values.

4.8.2 Dielectric Strength. When fuses are tested in accordance with 5.8.4, the leakage current shall not exceed 1 milliamperere.

4.8.3 X-Ray Inspection. When fuses are tested in accordance with 5.8.5, there shall be no rejections.

|              |   |                              |               |
|--------------|---|------------------------------|---------------|
| AEM, Inc.    | 11525 SORRENTO VALLEY RD<br>SAN DIEGO, CA 92121-1306. | TITLE<br>P700L SPECIFICATION |               |
| NUMBER P700L | REVISION J  | ECN 2139                     | SHEET 3 of 23 |

4.8.4 Current-Carrying Capacity (Group C / Qualification Only). When fuses are tested in accordance with 5.8.6, they shall show no evidence of mechanical damage and shall carry the current as specified without electrical failure. The temperature of the case or terminals shall at no point rise more than +85°C above the ambient air temperature. The maximum temperature rise for 6.0, 7.5, 10, 15 and 20 ampere fuses shall be +120°C.

4.8.5 Terminal Strength. When fuses are tested in accordance with 5.8.7, the lead terminals shall not break or loosen. The cold resistance values shall not change by more than 10 percent.

4.8.6 Thermal Vacuum (Qualification Only). When fuses are tested in accordance with 5.8.16, they shall not open circuit during the application of derated DC current nor shall there be evidence of arcing or mechanical damage after the test. Fuses that are subjected to the 400 percent overload current test shall "blow" within the time period specified (see Table VI). The cold resistance values of those fuses not subjected to the overload current shall not change by more than 10 percent when measured after thermal vacuum exposure.

4.8.7 Overload Current.

4.8.7.1 Overload Current Characterization. Each fuse lot shall be sampled to assure that the blow times fall within the limits of Table VI. Each lot shall be truncated to form an inspection lot based upon the cold resistance measured after thermal shock. The manufacturer shall blow samples (a minimum of 20 samples total) selected from the extremes of the truncated population to insure that their blow times are within the specification. The results of this procedure shall remain in the "Group A Data" with the lot data package.

4.8.7.2 Overload Current. Fuses selected from a truncated distribution shall be tested in accordance with 5.8.14. The clearing times and the maximum  $I^2t$  shall be as specified in Table VI. After clearing, the circuit shall remain open without closing again during a one-minute period. The let through energy during the one-minute period shall be included in the calculation of  $I^2t$ . The blown fuses shall meet the resistance after firing test of 4.8.8.

4.8.8 Resistance after Firing. When blown fuses are tested in accordance with 5.8.15, the minimum resistance shall be 10 megohms. The following exceptions shall apply for fuses with current ratings greater than 5 amperes:

- a) 250% Overload - A resistance value of 100K ohms minimum following the 250% overload test.
- b) Other Overloads - A resistance value of 1 megohm minimum following overload testing.

4.8.9 Moisture Resistance (Group C / Qualification Only). When fuses are tested in accordance with 5.8.8, there shall be no evidence of cracking or peeling of the fuse body, loosening of the terminals or excessive corrosion of the leads. The resistance of the fuses shall not change by more than 15 percent as a result of the moisture exposure.

4.8.10 Shock (Group C / Qualification Only). When fuses are tested in accordance with 5.8.9, there shall be no evidence of mechanical damage and the fuse resistance shall not change by more than 10 percent.

4.8.11 Vibration (Group C / Qualification Only). When fuses are tested in accordance with 5.8.10, there shall be no evidence of mechanical damage and the fuse resistance shall not change by more than 10 percent.

4.8.12 Low Temperature Operation (Group C / Qualification Only). When fuses are tested in accordance with 5.8.12, they shall not open circuit and the fuse resistance shall not change by more than 10 percent.

4.8.13 Life (2000 Hours, Group C / Qualification Only). When fuses are tested in accordance with 5.8.13, they shall not open circuit and the fuse resistance shall not change by more than 10 percent.

|           |       |   |   |                              |      |
|-----------|-------|---|---|------------------------------|------|
| AEM, Inc. |       | 11525 SORRENTO VALLEY RD<br>SAN DIEGO, CA 92121-1306. |   | TITLE<br>P700L SPECIFICATION |      |
| NUMBER    | P700L | REVISION  | J | ECN                          | 2139 |
|           |       |   |   | SHEET 4 of 23                |      |

4.8.14 Resistance to Soldering Heat (Group C / Qualification Only). When fuses are tested in accordance with 5.8.11, there shall be no mechanical damage and the fuse resistance shall not change by more than 10 percent.

4.8.15 Solderability. Fuses shall meet the solderability requirements specified in MIL-STD-202, Method 208.

4.8.16 Salt Spray (Group C / Qualification Only). When fuses are tested in accordance with 5.8.17, there shall be no evidence of excessive corrosion. Excessive corrosion is defined as that which interferes with the electrical or mechanical performance. There shall be no warping or cracking of the fuse body and the fuse resistance shall not change by more than 10 percent.

4.8.17 Outgassing (Qualification Only). When fuses are tested in accordance with 5.8.18, the materials shall meet the following requirements:

- a) Total mass loss (TML) - Shall not exceed 1.0 percent.
- b) Collected volatile condensable material (CVCM) - Shall not exceed 0.1 percent.

4.8.18 Short Circuit Interrupt (Group C / Qualification Only). When fuses are tested in accordance with 5.8.19, the resistance after short circuit testing shall be at least 1.0 megohm.

4.8.19 168-Hour Burn-In. When fuses are tested in accordance with 5.8.20, the fuse voltage-drop (as measured at 10% rated current) shall not have changed by more than +/-10% of the pre-thermally shocked value. There shall be no evidence of external mechanical damage.

4.9 Workmanship. Fuses shall meet the visual and mechanical criteria outlined in AEM Process Instructions P70617 and P70765 when inspected per 5.8.1.

4.9.1 Precap Inspection. Prior to molding all fuses shall be visually inspected with a minimum of 10 power magnification. Inspection criteria are outlined in the AEM Precap Document P700L-PA.

## 5. QUALITY ASSURANCE PROVISIONS

5.1 Classification of Inspection. The inspection of fuses procured to the requirements of this specification shall be classified as follows:

- a) Qualification Inspection (paragraph 5.6) when specified on the purchase order.
- b) Acceptance Inspection (paragraph 5.7).

5.2 Reliability Assurance Program. AEM shall ensure that a reliability assurance program is established and maintained in accordance with MIL-STD-790.

5.3 Test Equipment and Inspection Facilities. AEM shall establish and maintain a calibration system in accordance with MIL-STD-45662.

5.4 Acceptance Inspection Reports. AEM shall supply with each shipment of fuses the following minimum data:

- a) Non-standard test reports as required by the purchase order.
- b) Certification of Conformance signed by Quality Assurance Manager.
- c) Group C data, if required by the purchase order, shall be shipped at the completion of Group C inspection.

5.5 Inspection Conditions and Methods. Unless otherwise specified in this document, inspections shall be conducted at room ambient environments of +25°C +/- 5°C and the maximum relative humidity shall be 75 percent.

|              |   |                              |
|--------------|---|------------------------------|
| AEM, Inc.    | 11525 SORRENTO VALLEY RD<br>SAN DIEGO, CA 92121-1306. | TITLE<br>P700L SPECIFICATION |
| NUMBER P700L | REVISION J  | ECN 2139                     |
|              |   | SHEET 5 of 23                |

5.6 Qualification Inspection.

5.6.1 Qualification Samples. Samples submitted to qualification inspection shall be representative of the normal high reliability production. A sample of 32 fuses representing the lowest, middle, and highest cold resistance values within the truncated distribution shall be submitted for qualification inspection. At the completion of Subgroup I inspection, the 32 samples shall be divided into the subgroups and quantities shown in Table V. Each subgroup shall have approximately equal representation of the fuse cold resistance values.

5.7 Acceptance Inspection.

5.7.1 Inspection of Fuses for Delivery. Inspection of fuses for delivery against a purchase order shall consist of the tests listed in Table I.

5.7.2 Inspection Lot. An inspection lot shall consist of one amperage rating of one lot date code.

5.7.3 Group A Inspection. Group A inspection shall consist of the tests listed in Table II and shall be conducted in the order indicated.

5.7.4 Group B Inspection. Group B inspection shall consist of the tests listed in Table III and shall be conducted in the order indicated. All fuses submitted to Group B inspection shall have successfully met all electrical requirements of the Group A inspection (Visual rejects and X-Ray rejects may be utilized for Group B inspection).

5.7.5 Group C Inspection. Group C inspection, when required by the purchase order, shall consist of the tests listed in Table IV. The fuses submitted for Group C inspection shall have met Group A and Group B inspection requirements as part of the inspection lot from which they were taken. Group C inspection must be completed within 150 days after the completion of Group B inspection.

|              |   |                              |               |
|--------------|---|------------------------------|---------------|
| AEM, Inc.    | 11525 SORRENTO VALLEY RD<br>SAN DIEGO, CA 92121-1306. | TITLE<br>P700L SPECIFICATION |               |
| NUMBER P700L | REVISION J  | ECN 2139                     | SHEET 6 of 23 |

**TABLE II. GROUP A INSPECTION.**

| EXAMINATION OR TEST               | REQUIREMENT PARAGRAPH | METHOD PARAGRAPH | NUMBER OF UNITS SPECIFIED | NUMBER OF DEFECTIVES ALLOWED |
|-----------------------------------|-----------------------|------------------|---------------------------|------------------------------|
| PRECAP INSPECTION                 | 4.9.1                 |                  | 100%                      | N/A                          |
| VISUAL AND MECHANICAL EXAMINATION | 4.9                   | 5.8.1            | 100%                      | N/A                          |
| RESISTANCE                        | 4.6                   | 5.8.2            | 100%                      | N/A                          |
| THERMAL SHOCK                     | 4.8.1                 | 5.8.3            | 100%                      | /1                           |
| RESISTANCE                        | 4.6                   | 5.8.2            | 100%                      | N/A                          |
| OVERLOAD CURRENT CHARACTERIZATION | 4.8.7.1               | 5.8.14           | AS REQUIRED               | N/A                          |
| X-RAY INSPECTION                  | 4.8.3                 | 5.8.5            | 100%                      | N/A                          |
| VISUAL AND MECHANICAL EXAMINATION | 4.9                   | 5.8.1            | 100%                      | N/A                          |
| DIELECTRIC STRENGTH               | 4.8.2                 | 5.8.4            | MIL-PRF-23419 (APPENDIX)  | 0                            |

1/ THE MAXIMUM PDA FOR THERMAL SHOCK IS 5%.

|                     |   |                                      |                      |
|---------------------|---|--------------------------------------|----------------------|
| <b>AEM, Inc.</b>    | <b>11525 SORRENTO VALLEY RD<br/>SAN DIEGO, CA 92121-1306.</b> | <b>TITLE<br/>P700L SPECIFICATION</b> |                      |
| <b>NUMBER P700L</b> | <b>REVISION J</b>   | <b>ECN 2139</b>                      | <b>SHEET 7 of 23</b> |

**TABLE III. GROUP B INSPECTION.**

**Subgroup I: 20 Samples Required**

| Examination or Test     | Requirement Paragraph | Method Paragraph | Number of Samples (Note 1) | Number of Defectives Allowed |
|-------------------------|-----------------------|------------------|----------------------------|------------------------------|
| Solderability           | 4.8.15                |                  | 20                         | 0                            |
| Terminal Strength       | 4.8.5                 | 5.8.7            | 20                         | 0                            |
| Overload Current        | 4.8.7.2               | 5.8.14           | 20                         | 0                            |
| Resistance After Firing | 4.8.8                 | 5.8.15           | 20                         | 0                            |

**Notes:**

- 1) **Overload Current Samples Shall Be as Follows:**  
250% Overload Current – 12 Samples  
400% Overload Current – 4 Samples  
600% Overload Current – 4 Samples

**Subgroup II: 22 Samples Required:**

| Examination or Test | Requirement Paragraph | Method Paragraph | Number of Samples | Number of Defectives Allowed |
|---------------------|-----------------------|------------------|-------------------|------------------------------|
| Thermal Shock       | 4.8.1                 | 5.8.3            | 22                | 0                            |
| 168-Hour Burn-In    | 4.8.19                | 5.8.20           | 22                | 0                            |

|              |   |                              |               |
|--------------|---|------------------------------|---------------|
| AEM, Inc.    | 11525 SORRENTO VALLEY RD<br>SAN DIEGO, CA 92121-1306. | TITLE<br>P700L SPECIFICATION |               |
| NUMBER P700L | REVISION J  | ECN 2139                     | SHEET 8 of 23 |



**TABLE IV. GROUP C INSPECTION.**

| EXAMINATION OR TEST                          | REQUIREMENT PARAGRAPH | METHOD PARAGRAPH | NUMBER OF UNITS SPECIFIED | NUMBER OF DEFECTIVES ALLOWED |
|--|-----------------------|------------------|---------------------------|------------------------------|
| <u>SUBGROUP I (16 UNITS)</u>                 |                       |                  |                           |                              |
| LOW TEMP. OPERATION                          | 4.8.12                | 5.8.12           | 12                        | 0                            |
| LIFE (2000 HOURS)                            | 4.8.13                | 5.8.13           | 12                        | 0                            |
| OVERLOAD CURRENT                             | 4.8.7.2               | 5.8.14           | 12                        | 0                            |
| RESISTANCE AFTER FIRING                      | 4.8.8                 | 5.8.15           | 12                        | 0                            |
| SHORT CIRCUIT INTERRUPT                      | 4.8.18                | 5.8.19           | 4                         | 0                            |
| RESISTANCE AFTER FIRING                      | 4.8.8                 | 5.8.15           | 4                         | 0                            |
| <u>SUBGROUP II (6 UNITS)</u>                 |                       |                  |                           |                              |
| TERMINAL STRENGTH                            | 4.8.5                 | 5.8.7            | 6                         | 0                            |
| OVERLOAD CURRENT                             | 4.8.7.2               | 5.8.14           | 6                         | 0                            |
| MAX. CLEARING 600%                           | 4.8.7.2               | 5.8.14           |                           |                              |
| RESISTANCE AFTER FIRING                      | 4.8.8                 | 5.8.15           | 6                         | 0                            |
| <u>SUBGROUP III (4 UNITS)</u>                |                       |                  |                           |                              |
| VIBRATION                                    | 4.8.11                | 5.8.10           | 4                         | 0                            |
| SHOCK  | 4.8.10                | 5.8.9            | 4                         | 0                            |
| RES. TO SOLDERING HEAT                       | 4.8.14                | 5.8.11           | 4                         | 0                            |
| <u>SUBGROUP IV (4 UNITS)</u>                 |                       |                  |                           |                              |
| SALT SPRAY                                   | 4.8.16                | 5.8.17           | 4                         | 0                            |
| OVERLOAD CURRENT (+25C)                      | 4.8.7.2               | 5.8.14           | 4                         | 0                            |
| MAX. CLEARING 600%                           | 4.8.7.2               | 5.8.14           |                           |                              |
| RESISTANCE AFTER FIRING                      | 4.8.8                 | 5.8.15           | 4                         | 0                            |
| <u>SUBGROUP V (4 UNITS)</u>                  |                       |                  |                           |                              |
| MOISTURE RESISTANCE                          | 4.8.9                 | 5.8.8            | 4                         | 0                            |
| THERMAL SHOCK                                | 4.8.1                 | 5.8.3            | 4                         | 0                            |
| CURRENT-CARRYING CAP.<br>AT ROOM TEMP (+25C) | 4.8.4                 | 5.8.6            | 4                         | 0                            |

|                     |   |                                      |                      |
|---------------------|---|--------------------------------------|----------------------|
| <b>AEM, Inc.</b>    | <b>11525 SORRENTO VALLEY RD<br/>SAN DIEGO, CA 92121-1306.</b> | <b>TITLE<br/>P700L SPECIFICATION</b> |                      |
| <b>NUMBER P700L</b> | <b>REVISION J</b>   | <b>ECN 2139</b>                      | <b>SHEET 9 of 23</b> |

**TABLE V. QUALIFICATION INSPECTION.**

| EXAMINATION OR TEST  | REQUIREMENT PARAGRAPH | METHOD PARAGRAPH | NUMBER OF UNITS SPECIFIED | NUMBER OF DEFECTIVES ALLOWED |
|--|-----------------------|------------------|---------------------------|------------------------------|
| <u>SUBGROUP I (32 UNITS)</u>                                 |                       |                  |                           |                              |
| VISUAL AND MECHANICAL EXAMINATION                            | 4.9                   | 5.8.1            | ALL                       | 0                            |
| RESISTANCE   | 4.6                   | 5.8.2            | ALL                       | 0                            |
| CURRENT-CARRYING CAP.  | 4.8.4                 | 5.8.6            | ALL                       | 0                            |
| <u>SUBGROUP II (6 UNITS)</u>                                 |                       |                  |                           |                              |
| TERMINAL STRENGTH  | 4.8.5                 | 5.8.7            | 6                         | 0                            |
| OVERLOAD CURRENT (HIGH/LOW TEMPS. AND MAX. CLEARING AT 600%) | 4.8.7.2               | 5.8.14           | 6                         | 0                            |
| RESISTANCE AFTER FIRING                                      | 4.8.8                 | 5.8.15           | 6                         | 0                            |
| SOLDERABILITY  | 4.8.15                |                  | 6                         | 0                            |
| <u>SUBGROUP III (14 UNITS)</u>                               |                       |                  |                           |                              |
| LOW TEMP. OPERATION  | 4.8.12                | 5.8.12           | 6                         | 0                            |
| LIFE (2000 HOURS)  | 4.8.13                | 5.8.13           | 6                         | 0                            |
| OVERLOAD CURRENT (+25C)                                      | 4.8.7.2               | 5.8.14           | 6                         | 0                            |
| RESISTANCE AFTER FIRING                                      | 4.8.8                 | 5.8.15           | 6                         | 0                            |
| THERMAL VACUUM   | 4.8.6                 | 5.8.16           | 4                         | 0                            |
| OVERLOAD CURRENT (400%)                                      | 4.8.7.2               | 5.8.14           | 2                         | 0                            |
| RESISTANCE AFTER FIRING                                      | 4.8.8                 | 5.8.15           | 2                         | 0                            |
| SHORT CIRCUIT INTERRUPT                                      | 4.8.18                | 5.8.19           | 4                         | 0                            |
| RESISTANCE AFTER FIRING                                      | 4.8.8                 | 5.8.15           | 4                         | 0                            |
| <u>SUBGROUP IV (4 UNITS)</u>                                 |                       |                  |                           |                              |
| VIBRATION  | 4.8.11                | 5.8.10           | 4                         | 0                            |
| SHOCK  | 4.8.10                | 5.8.9            | 4                         | 0                            |
| <u>SUBGROUP V (4 UNITS)</u>                                  |                       |                  |                           |                              |
| SALT SPRAY   | 4.8.16                | 5.8.17           | 4                         | 0                            |
| OVERLOAD CURRENT (+25C)                                      | 4.8.7.2               | 5.8.14           | 4                         | 0                            |
| (MAX. CLEARING AT 600%)                                      | 4.8.7.2               | 5.8.14           |                           |                              |
| RESISTANCE AFTER FIRING                                      | 4.8.8                 | 5.8.15           | 4                         | 0                            |
| <u>SUBGROUP VI (4 UNITS)</u>                                 |                       |                  |                           |                              |
| OUTGASSING   | 4.8.17                | 5.8.18           | 4                         | 0                            |
| MOISTURE RESISTANCE  | 4.8.9                 | 5.8.8            | 4                         | 0                            |
| THERMAL SHOCK  | 4.8.1                 | 5.8.3            | 4                         | 0                            |
| RES. TO SOLDERING HEAT                                       | 4.8.14                | 5.8.11           | 4                         | 0                            |
| CURRENT CARRYING CAP. AT ROOM TEMP. (+25 C)                  | 4.8.4                 | 5.8.6            | 4                         | 0                            |
| OVERLOAD CURRENT (+25C)                                      | 4.8.7.2               | 5.8.14           | 4                         | 0                            |
| RESISTANCE AFTER FIRING                                      | 4.8.8                 | 5.8.15           | 4                         | 0                            |

|                     |   |                                      |                       |
|---------------------|---|--------------------------------------|-----------------------|
| <b>AEM, Inc.</b>    | <b>11525 SORRENTO VALLEY RD<br/>SAN DIEGO, CA 92121-1306.</b> | <b>TITLE<br/>P700L SPECIFICATION</b> |                       |
| <b>NUMBER P700L</b> | <b>REVISION J</b>   | <b>ECN 2139</b>                      | <b>SHEET 10 of 23</b> |

**TABLE VI. ELECTRICAL AND MECHANICAL REQUIREMENTS.**

| FUSE PART NUMBER / RATINGS |                       |                       | COLD RESISTANCE (OHMS) 1/ |         | FIGURE (1 OR 2) | OVERLOAD INTERRUPT TIME (SECONDS) 2/ |                      |                     | MAXIMUM I <sup>2</sup> T (AMPERE <sup>2</sup> SECONDS) 3/ |                      |                     |
|----------------------------|-----------------------|-----------------------|---------------------------|---------|-----------------|--------------------------------------|----------------------|---------------------|---|----------------------|---------------------|
| P700L PART NO. 4/          | MAXIMUM VOLTAGE (VDC) | CURRENT RATING (AMPS) | MINIMUM                   | MAXIMUM |                 | 250 % NOMINAL RATING                 | 400 % NOMINAL RATING | 600% NOMINAL RATING | 250 % NOMINAL RATING                                      | 400 % NOMINAL RATING | 600% NOMINAL RATING |
| P700L-72-1/8               | 72                    | 1/8                   | 6.375                     | 10.625  | 1               | .005-30.0                            | .0005-.015           | .000075-.003        | 2.930   | 0.004                | 0.002               |
| P700L-72-1/4               | 72                    | 1/4                   | 1.875                     | 3.125   | 1               | .005-30.0                            | .0005-.015           | .000075-.003        | 11.719  | 0.015                | 0.007               |
| P700L-72-3/8               | 72                    | 3/8                   | 1.125                     | 1.875   | 1               | .005-.5                              | ↑                    | ↑                   | 0.439   | 0.034                | 0.015               |
| P700L-72-1/2               | 72                    | 1/2                   | 0.675                     | 1.125   | 1               | ↑                                    | ↑                    | ↑                   | 0.781   | 0.060                | 0.027               |
| P700L-72-3/4               | 72                    | 3/4                   | 0.225                     | 0.375   | 1               | ↑                                    | ↑                    | ↑                   | 1.758   | 0.135                | 0.061               |
| P700L-72-1.0               | 72                    | 1.0                   | 0.135                     | 0.225   | 1               | ↑                                    | ↑                    | ↑                   | 3.125   | 0.240                | 0.108               |
| P700L-72-1.5               | 72                    | 1.5                   | 0.097                     | 0.163   | 1               | ↑                                    | ↑                    | ↑                   | 7.031   | 0.540                | 0.243               |
| P700L-72-2.0               | 72                    | 2.0                   | 0.045                     | 0.075   | 1               | ↑                                    | ↑                    | ↑                   | 12.500  | 0.960                | 0.432               |
| P700L-72-3.0               | 72                    | 3.0                   | 0.0262                    | 0.0438  | 1               | ↑                                    | ↑                    | ↑                   | 28.125  | 2.160                | 0.972               |
| P700L-72-4.0               | 72                    | 4.0                   | 0.0195                    | 0.0325  | 1               | ↑                                    | ↑                    | ↑                   | 50.000  | 3.840                | 1.728               |
| P700L-72-5.0               | 72                    | 5.0                   | 0.0135                    | 0.0225  | 1               | ↑                                    | ↑                    | ↑                   | 78.125  | 6.000                | 2.700               |
| P700L-72-6.0               | 72                    | 6.0                   | 0.0100                    | 0.0180  | 1               | ↑                                    | ↑                    | ↑                   | 112.500   | 8.640                | 3.888               |
| P700L-72-7.5               | 72                    | 7.5                   | 0.0070                    | 0.0110  | 1               | ↑                                    | ↑                    | ↑                   | 175.781   | 13.500               | 6.075               |
| P700L-72-10.0              | 72                    | 10                    | 0.0046                    | 0.0079  | 1               | ↑                                    | ↑                    | ↑                   | 312.500   | 24.000               | 10.800              |
| P700L-72-15.0              | 72                    | 15                    | 0.0040                    | 0.0075  | 2               | ↓                                    | ↓                    | ↓                   | 703.125   | 54.000               | 24.300              |
| P700L-50-20.0              | 50                    | 20                    | 0.0020                    | 0.0056  | 2               | .005-.5                              | ↓                    | ↓                   | 1250.000  | 96.000               | 43.200              |
| P700L-125-1/8              | 125                   | 1/8                   | 6.375                     | 10.625  | 1               | .005-30.0                            | ↓                    | ↓                   | 2.930   | 0.004                | 0.002               |
| P700L-125-1/4              | 125                   | 1/4                   | 1.875                     | 3.125   | 1               | .005-30.0                            | ↓                    | ↓                   | 11.719  | 0.015                | 0.007               |
| P700L-125-3/8              | 125                   | 3/8                   | 1.125                     | 1.875   | 1               | .005-.5                              | ↓                    | ↓                   | 0.439   | 0.034                | 0.015               |
| P700L-125-1/2              | 125                   | 1/2                   | 0.675                     | 1.125   | 2               | ↑                                    | ↓                    | ↓                   | 0.781   | 0.060                | 0.027               |
| P700L-125-3/4              | 125                   | 3/4                   | 0.225                     | 0.375   | 2               | ↑                                    | ↓                    | ↓                   | 1.758   | 0.135                | 0.061               |
| P700L-125-1.0              | 125                   | 1.0                   | 0.090                     | 0.270   | 2               | ↑                                    | ↓                    | ↓                   | 3.125   | 0.240                | 0.108               |
| P700L-125-1.5              | 125                   | 1.5                   | 0.085                     | 0.225   | 2               | ↑                                    | ↓                    | ↓                   | 7.031   | 0.540                | 0.243               |
| P700L-125-2.0              | 125                   | 2.0                   | 0.045                     | 0.135   | 2               | ↑                                    | ↓                    | ↓                   | 12.500  | 0.960                | 0.432               |
| P700L-125-3.0              | 125                   | 3.0                   | 0.035                     | 0.105   | 2               | ↑                                    | ↓                    | ↓                   | 28.125  | 2.160                | 0.972               |
| P700L-125-4.0              | 125                   | 4.0                   | 0.030                     | 0.090   | 2               | ↑                                    | ↓                    | ↓                   | 50.000  | 3.840                | 1.728               |
| P700L-125-5.0              | 125                   | 5.0                   | 0.022                     | 0.068   | 2               | .005-.5                              | .0005-.015           | .000075-.003        | 78.125  | 6.000                | 2.700               |

1/ Cold Resistance is measured at from 0.1 to 10 milliamperes of current or calculated from the measured Voltage Drop at a current not exceeding 10% of the rated current of the fuse.

2/ Overload interrupt times at -55 C and 250% overload current shall be as follows:

- a) Fuses with ratings less than 3/8 amperes shall open in 60 seconds maximum.
- b) Fuses with ratings from 3/8 to 1.0 ampere shall open in 10 seconds maximum.
- c) Fuses with ratings greater than 1.0 ampere shall open in 5 seconds maximum.

3/ Maximum I<sup>2</sup>T at -55 C and 250% overload current may be greater than indicated . To calculate maximum I<sup>2</sup>T at case temperatures of -55 C and 250% overload current , multiply the I<sup>2</sup> product by the maximum blow times indicated in note 2 above.

4/ Standard P700L part type is manufactured with an internal solder of type Sn96 / Ag4. Non-standard P700LH part type (High Temperature) is manufactured with an internal solder of type Sn10 / Pb88 / Ag2.

Ordering Example:

- A) Standard (Sn96 / Ag4 internal solder) P700L, 72 VDC, 5 amp part type shall be ordered as P700L-72-5.0.
- B) Non-standard (Sn10 / Pb88 / Ag 2 internal solder) P700L, 72 VDC, 5 amp part type shall be ordered as P700LH-72-5.0.

|                  |              |   |                       |                                      |             |
|------------------|--------------|---|-----------------------|--------------------------------------|-------------|
| <b>AEM, Inc.</b> |              | <b>11525 SORRENTO VALLEY RD<br/>SAN DIEGO, CA 92121-1306.</b> |                       | <b>TITLE<br/>P700L SPECIFICATION</b> |             |
| <b>NUMBER</b>    | <b>P700L</b> | <b>REVISION</b>   | <b>J</b>              | <b>ECN</b>                           | <b>2139</b> |
|                  |              |   | <b>SHEET 11 of 23</b> |                                      |             |

5.8 Methods of Examination and Test.

5.8.1 Visual and Mechanical Inspection. Fuses shall be visually and mechanically examined per AEM Process Instruction P70617 following the molding operation. Fuses shall be visually and mechanically examined per AEM Process Instruction P70765 following the final assembly and marking operations.

5.8.2 Resistance. The resistance of the fuse shall be measured using a constant current DC source having an open circuit voltage not greater than the voltage rating of the fuse. The resistance of the fuse shall be measured using one of the following two methods:

Method I: The resistance shall be measured using a constant current DC source having an open circuit voltage not greater than the voltage rating of the fuse. The measurement current shall be from 0.1 to 10 milliamperes and provide a measurement accuracy of +/- 1%. A Keithley Model 580 Micro-Ohmmeter or equivalent is recommended for these measurements.

Method II: The fuses shall be electrically connected to a constant DC source supplying 10% of the rated current of the fuse and having an open circuit voltage not greater than the voltage rating of the fuse. The voltage drop of each fuse shall be measured and the resistance calculated from the measured voltage drop.

5.8.3 Thermal Shock. Fuses shall be tested in accordance with Method 107, Test Condition B, of MIL-STD-202. A total of five cycles shall be run without interruption. The cold resistance of the fuses shall be measured before and after the five cycles in accordance with 5.8.2.

5.8.4 Dielectric Strength. Fuses shall be tested in accordance with Method 301 of MIL-STD-202. Fuses shall be mounted in a test fixture capable of exposing all major surfaces of the fuse body and leads to the test voltage. The test voltage shall be applied to the terminals electrically tied together and to the test fixture. The following details shall apply:

- a) Test voltage - 500 VRMS.
- b) Duration - 5 seconds for acceptance tests.  
- 60 seconds for qualification tests.
- c) Leakage current - 1 milliampere maximum.
- d) Measurements - DC resistance of the fuse after the dielectric strength exposure in accordance with 5.8.2.

5.8.5 X-Ray Inspection. Fuses shall be subjected to radiographic inspection in accordance with Method 209 of MIL-STD-202. The following details shall apply:

- a) The radiograph shall be of sufficient quality to render a clear, sharp image of the penetrameter.
- b) The source-object distance shall ensure a sharply defined image.
- c) Two views of each fuse (0° and 90°) shall be provided.
- d) A radiograph penetrameter shall be included on each radiographic film.
- e) Radiographs shall be examined at 10X magnification for the defects specified in AEM P700L-R Specification.

|              |   |                              |
|--------------|---|------------------------------|
| AEM, Inc.    | 11525 SORRENTO VALLEY RD<br>SAN DIEGO, CA 92121-1306. | TITLE<br>P700L SPECIFICATION |
| NUMBER P700L | REVISION J  | ECN 2139                     |
|              |   | SHEET 12 of 23               |

5.8.6 Current-Carrying Capacity (Group C / Qualification Only). Fuse samples shall be apportioned and submitted to the following DC test currents at -55°C to -60°C, at +20°C to +35°C (room ambient temperature), and at +125°C to +130°C:

| <u>Test Temperature</u> | <u>DC Test Current</u> |
|-------------------------|------------------------|
| - 55°C                  | 110% of Rated          |
| + 25°C                  | 100% of Rated          |
| + 125°C                 | 80% of Rated           |

The test current shall be maintained for 30 minutes after the temperature of each fuse has stabilized, but shall not be applied for less than 1.5 hours. It may be assumed that the temperature has stabilized when three consecutive temperature readings taken at 10 minute intervals show no rise in temperature. The temperature of the fuse body shall be measured by thermocouples (wire size 28 to 32 AWG).

5.8.7 Terminal Strength. Fuses shall be tested in accordance with Method 211 of MIL-STD-202. The following exceptions shall apply:

- a) Test Condition - Test Condition A (5 lb pull) applying the force axially to each lead wire individually (solder .026 inch diameter wires to leads prior to testing).
- b) Method of Holding - The fuse body shall be held by means other than rigid clamping to prevent stresses from being transferred to the fuse element.
- c) Measurements - DC resistance measurements shall be taken before and after exposure in accordance with 5.8.2.

5.8.8 Moisture Resistance (Group C / Qualification Only). Fuses shall be tested in accordance with Method 106 of MIL-STD-202. The following exceptions shall apply:

- a) Mounting - Normal mounting means on a noncorrosive metal panel positioned 15 degrees from the vertical with the terminals facing up.
- b) Polarizing voltage shall be 100 volts DC.
- c) Steps 7a and 7b are not applicable.
- d) Measurements - DC resistance measurements shall be taken before and after the exposure in accordance with 5.8.2.

5.8.9 Shock (Group C / Qualification Only). Fuses shall be tested in accordance with Method 213 of MIL-STD-202. The following details and exceptions shall apply:

- a) Mounting - Fuses shall be securely fastened to the table of the shock machine to prevent relative motion between the fuses and the table.
- b) Test Condition - F (except 1500G, 0.5 milliseconds, half-sine)
- c) Loading during Test - Rated DC current on half of the samples tested.
- d) Number of Shocks - Three shocks in each direction of three mutually perpendicular axes (18 shocks total).
- e) Measurements - DC resistance measurements shall be taken before and after the shock exposure in accordance with 5.8.2.

|           |       |   |   |                              |      |
|-----------|-------|---|---|------------------------------|------|
| AEM, Inc. |       | 11525 SORRENTO VALLEY RD<br>SAN DIEGO, CA 92121-1306. |   | TITLE<br>P700L SPECIFICATION |      |
| NUMBER    | P700L | REVISION  | J | ECN                          | 2139 |
|           |       |   |   | SHEET 13 of 23               |      |

5.8.10 Vibration (Group C / Qualification Only). Fuses shall be tested in accordance with Method 204 of MIL-STD-202. The following details and exceptions shall apply:

- a) Mounting - Fuses shall be securely fastened to the table of the vibration machine to prevent relative motion between the fuses and the table.
- b) Test Level - Sinusoidal vibration from 5 to 3000 hertz, 0.4 inch double amplitude or 30G's peak, whichever is less.
- c) Sweep Rate - Approximately 1/2 octave per minute.
- d) Test Duration - 12 hours total (4 hours in each of three major axes).
- e) Loading during Testing - Rated DC current on half of the samples tested.
- f) Measurements - DC resistance measurements shall be taken before and after the vibration exposure in accordance with 5.8.2.

5.8.11 Resistance to Soldering Heat (Group C / Qualification Only). Fuses shall be tested in a vapor phase test device and the boiling liquid shall be FC-70 or equivalent. A thermocouple (wire size 28 to 32 AWG) shall be attached to the body of one fuse for the purpose of monitoring case temperature during testing. The test samples shall be placed in the vapor for a period of 180 +/- 10 seconds after the case temperature has reached a temperature of +215°C. After the vapor exposure, the fuses shall be allowed to cool for 10 minutes at room temperature. The DC resistance of the fuses shall be measured before and after the test in accordance with 5.8.2.

5.8.12 Low Temperature Operation (Group C / Qualification Only). Fuses shall be soldered to test boards and placed in a low temperature chamber. The chamber temperature shall be lowered gradually to -55°C +/- 3°C within a period of 1 hour. After stabilizing at the low temperature for a period of 1 hour, rated DC current shall be applied to the fuses for a period of 4 +/- 0 hours while at the low temperature. The chamber shall then be gradually raised to room temperature within a 4 hour period and maintained at room temperature for a period of 8 hours minimum. After this time, the DC current shall be removed from the fuses and the fuses removed from the chamber. The DC resistance of the fuses shall be measured before and after the test in accordance with 5.8.2.

5.8.13 Life (2000 Hours, Group C / Qualification Only). Fuses shall be soldered on a suitable test board and placed in a chamber at +125°C +/- 0°C ambient. The fuses shall be electrically connected to a DC source supplying 64 percent of the +25°C rated current. The current source shall supply an open circuit voltage equal to the voltage rating of the fuses. The fuses shall remain in the chamber at the specified current for 2000 +/- 8 hours. The electrical circuit shall provide a suitable indicator, which shall be monitored daily during the length of the life test, to identify failure (blowing) of any fuse. The time of failure shall be recorded to the nearest +/- 12 hours and the blown fuse replaced with a short circuit for the remainder of the test. The DC resistance of the fuses shall be measured before and after the test in accordance with 5.8.2.

5.8.14 Overload Current. Fuses shall be subjected to the applicable percent of DC current (250%, 400% or 600%) as specified in Table VI. For Group B and Group C inspections, the fuses shall be tested while at case temperatures of +25° to +35°C. For qualification inspection (Subgroup II, Table V) and Group C inspection (Subgroup II, Table IV) the fuses shall be divided equally and tested at +25°C to 35°C, and at +125°C to +130°C. The low impedance source shall be adjusted to supply an open circuit voltage equal to the rating of the fuse. The time to "blow" (the interval measured from the application of the current to the time the current drops below the rating of the fuse) shall be measured for each fuse. Each fuse shall remain in the test circuit for 1 minute after the fuse opens to check for restrike conditions. The maximum clearing I<sup>2</sup>T shall be determined using an oscillogram showing the current trace. The determination shall be made by application of Simpson's rule. A recommended test circuit is shown in Figure 3.

5.8.15 Resistance after Firing. The open resistance of the "blown" fuse shall be measured by applying rated DC voltage across the terminals of the fuse. The resistance value shall be taken after a one-minute application of the test voltage.

|           |       |   |   |                              |      |
|-----------|-------|---|---|------------------------------|------|
| AEM, Inc. |       | 11525 SORRENTO VALLEY RD<br>SAN DIEGO, CA 92121-1306. |   | TITLE<br>P700L SPECIFICATION |      |
| NUMBER    | P700L | REVISION  | J | ECN                          | 2139 |
|           |       |   |   | SHEET 14 of 23               |      |

5.8.16 Thermal Vacuum (Qualification Only). Fuses shall be mounted in suitable mount sockets. The fuses shall then be placed in a vacuum chamber and the chamber evacuated to a pressure of  $5 \times 10^{-5}$  torr maximum. The temperature of the fuse mount shall be controlled such that the temperature of the fuses, measured with a thermocouple mounted on the fuse body, is maintained at  $+125 \pm 3^\circ\text{C}$  for a period of  $48 \pm 4, -0$  hours, while 90% of the  $+25^\circ\text{C}$  rated current is flowing through each fuse. At the end of the 48 hour exposure and while the fuses are at the test temperature and pressure, half of the samples shall be given an overload current at 400 percent of their rated current using the procedure specified in 5.8.14. The fuses shall then be removed from the chamber and the remaining fuses (not blown) measured for DC resistance in accordance with 5.8.2.

5.8.17 Salt Spray (Group C / Qualification Only). Fuses shall be tested in accordance with Method 101 of MIL-STD-202. The following details shall apply:

- a) Five percent salt solution.
- b) Test Condition B.
- c) Following the drying period, the fuses shall be subjected to 100 percent of rated current for 1 hour.
- d) Following the test the fuses shall be examined for compliance with 4.8.16.

5.8.18 Outgassing (Qualification Only). The fuses or fuse materials shall be tested as specified in ASTM E595.

5.8.19 Short Circuit Interrupt (Group C / Qualification Only). Fuses shall be placed in a DC test circuit capable of supplying a minimum of 1000 amperes. The test circuit shall be made using appropriate generating equipment as a source of power and with the rate of current rise for the test circuit adjusted for at least  $3.25 \times 10^6$  amperes per second. The open circuit voltage of the test circuit shall be adjusted to a value equal to the maximum rating of the fuse to be tested.

5.8.20 168-Hour Burn-In Testing (Group B). Fuses shall be solder mounted onto suitable test boards and connected in an electrically series circuit. Prior to testing, the voltage-drop (at 10% rated current) of each fuse shall be measured and recorded. Voltage-drop measurements shall be accomplished by probing the fuse leads in the lead egress area. The mounted fuses shall then be subjected to 5 cycles of thermal shock testing per paragraph 5.8.3. Following the thermal shock exposure, the fuses shall be subjected to 168 hours ( $\pm 4/0$  hours) of rated current testing. During burn-in testing, the ambient room temperature shall be maintained at from  $+25^\circ\text{C}$  to  $+28^\circ\text{C}$ . Fuse case temperature will not be controlled during the burn-in test. Following the 168-hour burn-in exposure, the fuse voltage-drop at 10% rated current shall be measured.

|              |   |                              |
|--------------|---|------------------------------|
| AEM, Inc.    | 11525 SORRENTO VALLEY RD<br>SAN DIEGO, CA 92121-1306. | TITLE<br>P700L SPECIFICATION |
| NUMBER P700L | REVISION J  | ECN 2139                     |
|              |   | SHEET 15 of 23               |

6. APPLICATIONS

6.1 Parallel Operation. Fuses may be used in parallel operation to gain current-carrying capability. When fuses are to be utilized in parallel configurations, the fuses shall be procured as matched sets. The requirements for matched set fuses are indicated below.

- a) Each matched set shall consist of two or more fuses.
- b) Matched set fuses shall be from the same manufacturing lot (same voltage and current rating).
- c) Matched set fuses shall be created by matching individual cold resistance values within the set to within 1% (highest to lowest within individual set). The cold resistance values used for matching shall be extracted from the resistance values measured following the thermal shock test.
- d) Matched set fuses shall be marked in accordance with paragraph 4.7 except that the part number shall be modified to indicate the set amperage value and the number of fuses within the set (see matched set examples below). Additionally, matched set serial label shall be placed on the side of each part. Matched set serial labels shall consist of a unique number for each fuse set, followed by a unique letter for each fuse within the set (i.e., 001A, 001B, 001C, 001D; 002A, 002B, 002C, 002D; etc.). Matched fuses may exceed the maximum width dimension by .010 inches as a result of the match set label.
- e) Matched set fuses shall be packaged together, separate from other matched set fuses.
- f) Data generated by the matching requirement shall be included with fuse shipment.
- g) The number of fuses within the matched set shall be specified on the purchase order.

Matched-Set Examples:

P700L-72-30.0-M2 (two P700L-72-15.0 supplied as a matched set forming a 30 amp equivalent fuse)  
P700L-50-40.0-M2 (two P700L-50-20.0 supplied as a matched set forming a 40 amp equivalent fuse)

6.2 Installation. Fuses may be mounted directly onto a printed circuit board. As the internal solder utilized for the standard P700L part type is Sn96 / Ag4, the maximum fuse case temperature should not exceed 221°C during the board level solder reflow processing.

6.3 Application Notes.

6.3.1 Thermal Shock Environments. When operation is required in temperature cycled environments, P700L part types (Sn96 / Ag4 internal solder) are suggested. Extensive thermal shock testing at AEM has shown this part type capable of withstanding over 1000 cycles of thermal shock when tested per Method 107 of Mil-Std-202 (-65°C to +125°C).

|              |   |                              |                |
|--------------|---|------------------------------|----------------|
| AEM, Inc.    | 11525 SORRENTO VALLEY RD<br>SAN DIEGO, CA 92121-1306. | TITLE<br>P700L SPECIFICATION |                |
| NUMBER P700L | REVISION J  | ECN 2139                     | SHEET 16 of 23 |



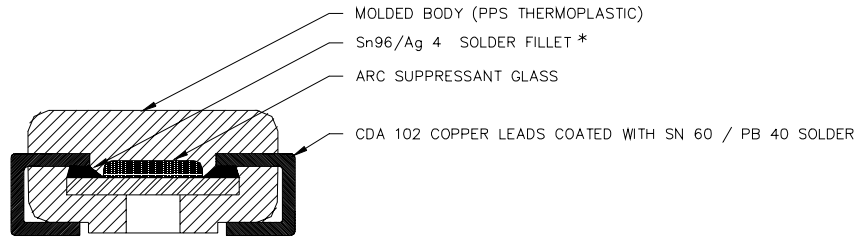
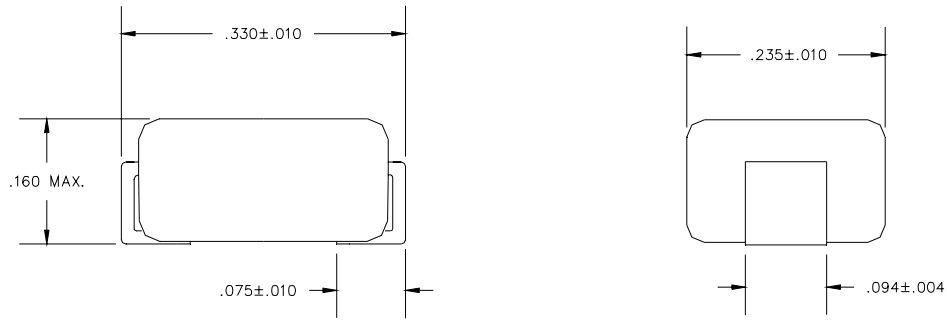

SECTIONAL VIEW

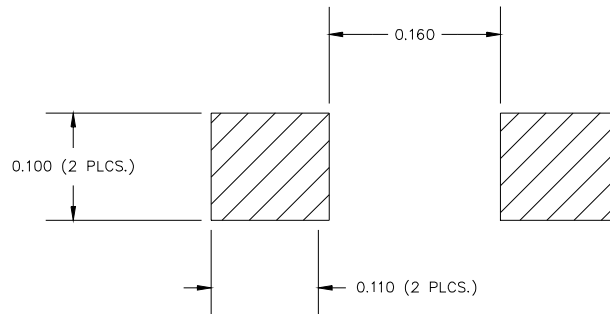

SUGGESTED LAND PATTERN

Dimensions are in inches.  
 Contour optional within dimensional limits.  
 Lead terminals shall be copper.  
 Maximum weight shall be 0.5 grams.  
 Minimum marking shall be abbreviated:

Marking Example:

Pin No.: P700L  
 Current Rating: 7.5A (ex.)  
 Voltage Rating: 72 VDC  
 Lot Code: C-XXXX

\* Internal solder fillet for Non-Standard P700LH option shall be Sn10/Pb 88/Ag 2.

**FIGURE 1. DIMENSIONS, CONSTRUCTION AND MARKING.**

|              |   |                              |                |
|--------------|---|------------------------------|----------------|
| AEM, Inc.    | 11525 SORRENTO VALLEY RD<br>SAN DIEGO, CA 92121-1306. | TITLE<br>P700L SPECIFICATION |                |
| NUMBER P700L | REVISION J  | ECN 2139                     | SHEET 17 of 23 |

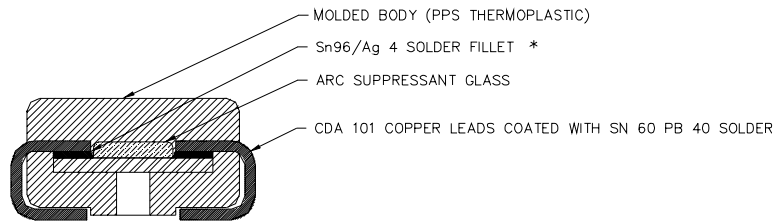
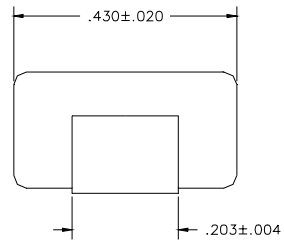
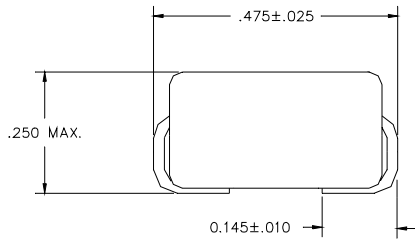

SECTIONAL VIEW

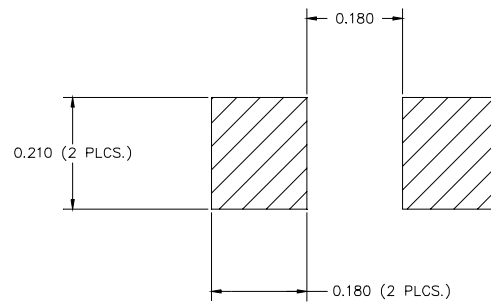

SUGGESTED LAND PATTERN

1. Dimensions are in inches.
2. Contour optional within dimensional limits.
3. Lead terminals shall be copper.
4. Maximum weight shall be 1.85 grams.
5. Minimum marking shall be abbreviated:

Marking Example:

Pin No.: P700L  
 Current Rating: 5.0A  
 Voltage Rating: 125 VDC  
 Lot Code: C-XXXX

\* Internal solder fillet for Non-standard P700LH option shall be Sn10/Pb 88/Ag 2.

**FIGURE 2. DIMENSIONS, CONSTRUCTION AND MARKING**

|              |   |                              |                |
|--------------|---|------------------------------|----------------|
| AEM, Inc.    | 11525 SORRENTO VALLEY RD<br>SAN DIEGO, CA 92121-1306. | TITLE<br>P700L SPECIFICATION |                |
| NUMBER P700L | REVISION J  | ECN 2139                     | SHEET 18 of 23 |

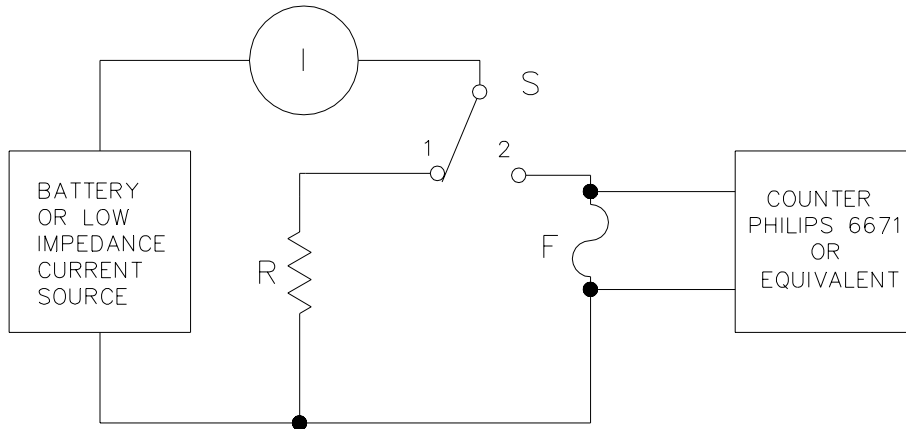

NOTES:

- R = Non-inductive resistor equal to the ohmic value of the fuse being tested.
- S = Non-bounce high current switch.
- I = Current adjusted to percent overload with switch in position 1.
- F = Current limiting fuse under test.

**FIGURE 3. OVERLOAD CURRENT TEST CIRCUIT.**

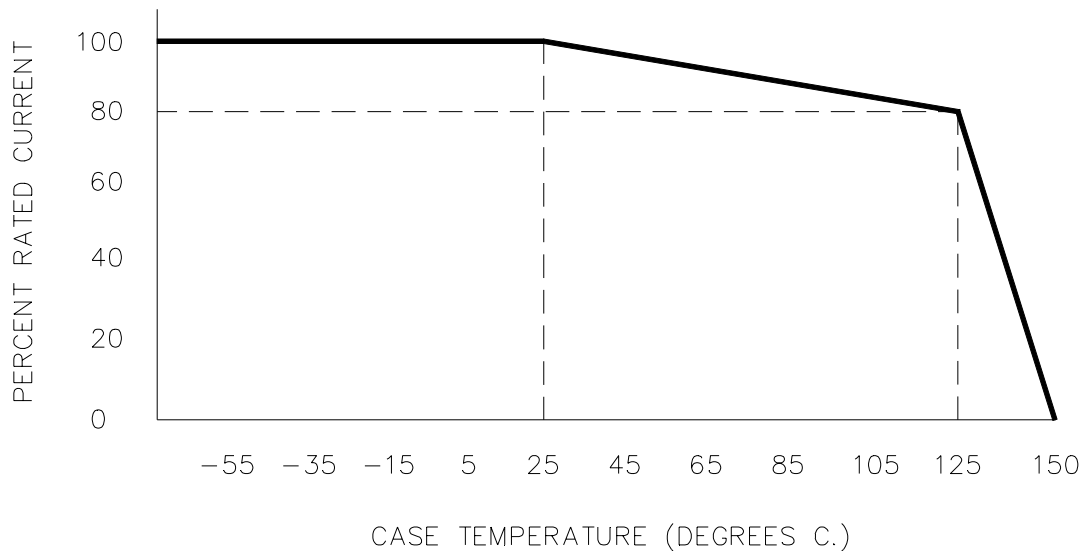

**FIGURE 4. CURRENT DERATING LIMITS.**

|              |   |                              |
|--------------|---|------------------------------|
| AEM, Inc.    | 11525 SORRENTO VALLEY RD<br>SAN DIEGO, CA 92121-1306. | TITLE<br>P700L SPECIFICATION |
| NUMBER P700L | REVISION J  | ECN 2139                     |
|              |   | SHEET 19 of 23               |

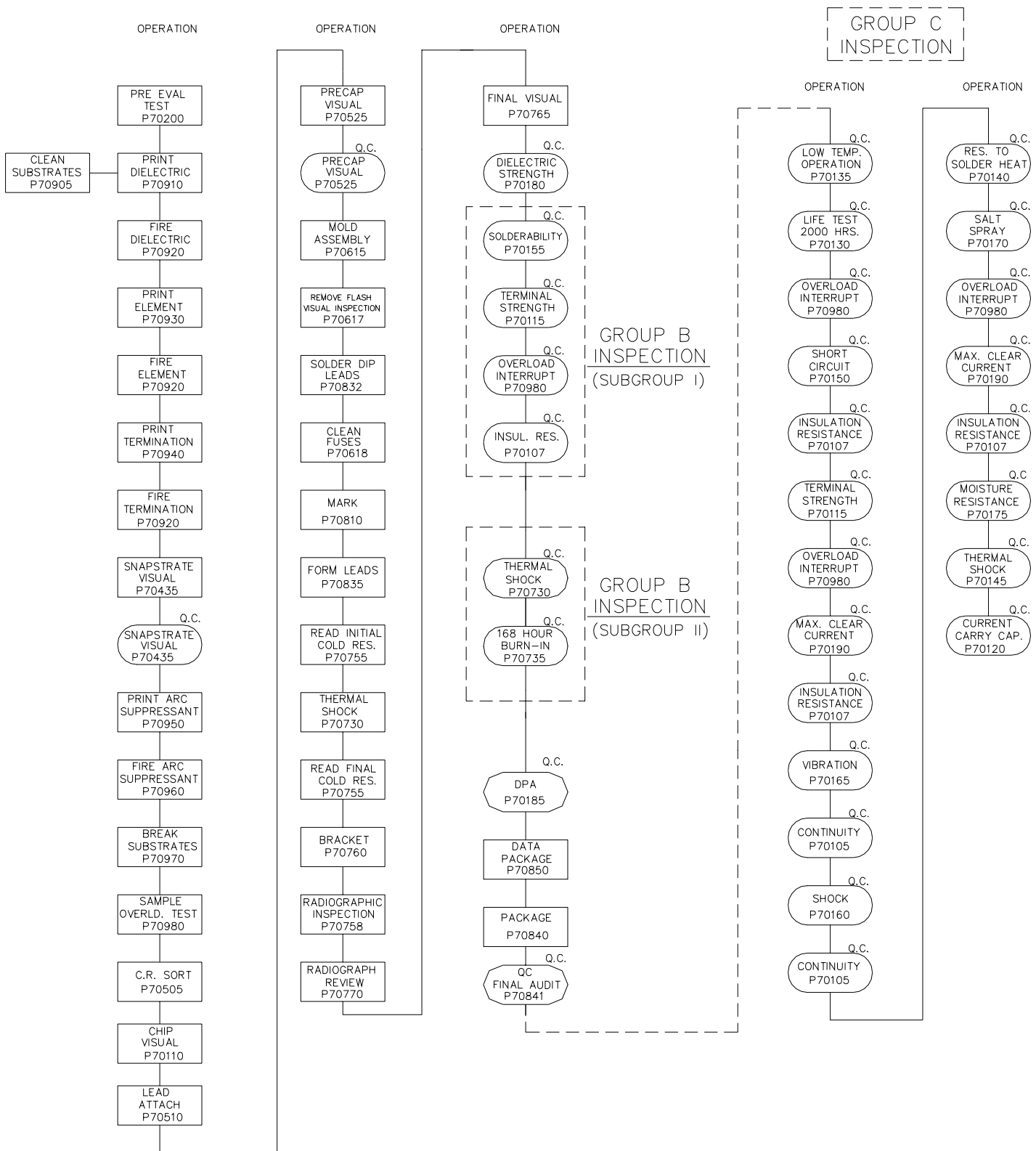

**FIGURE 5. OPERATIONS FLOW CHART.**

|                     |   |                                      |                       |
|---------------------|---|--------------------------------------|-----------------------|
| <b>AEM, Inc.</b>    | <b>11525 SORRENTO VALLEY RD<br/>SAN DIEGO, CA 92121-1306.</b> | <b>TITLE<br/>P700L SPECIFICATION</b> |                       |
| <b>NUMBER P700L</b> | <b>REVISION J</b>   | <b>ECN 2139</b>                      | <b>SHEET 20 of 23</b> |

## DOCUMENTATION CHANGE NOTICE

| <u>REV. LETTER</u> | <u>REV. DATE</u> | <u>PAGE</u> | <u>CHANGE ITEM</u>  | <u>APPROVAL</u> |
|--------------------|------------------|-------------|---|-----------------|
| A                  | 11-25-95         | N/A         | Issue New Drawing   | F.D.            |
| B                  | 8-8-94           | 14          | Para. 5.8.8; Revised Terminal Strength Test To Include Addition Of .026 Dia. Wire.                                | F.D.            |
| C                  | 6-2-95           | 10          | Revised Group C Test Plan Per Mil-PRF-23419/12 Spec.  | J.M.            |
|                    |                  | All         | Changed Company References From Mepcopal to AEM.  |                 |
| D                  | 10-10-95         | 17          | Para. 6.2; Added Note to include that case temperature should not exceed 215°C at any time during reflow process. |                 |
|                    |                  | 8           | Revised Table II; Added Resistance measurement before Thermal Shock.  |                 |
|                    |                  | 13          | Para. 5.8.2; Added Method II.   |                 |
| E                  | 2-9-96           | ALL         | Added "Group C / Qualification Only" for all Group C / Qual. Test paragraphs.                                     | J.M.            |
|                    |                  | ALL         | Removed all references to MIL-STD-690.  |                 |
|                    |                  | ALL         | Removed all references to Mepcopal.   |                 |
|                    |                  | 4           | Revised para. 4.6.  |                 |
|                    |                  | 5           | Revised para. 4.8.6.1 to 20 samples min.  |                 |
|                    |                  | 6           | Revised para. 4.9.  |                 |
|                    |                  | 7           | Revised para. 5.3 and 5.7.5.  |                 |
|                    |                  | 8           | Revised Table II (Position of DWV Test) added PDA Note 1.   |                 |
|                    |                  | 10          | Revised Table IV to follow MIL-PRF-23419/12.  |                 |
|                    |                  | 11          | Revised Table V to follow MIL-PRF-23419/12  |                 |
|                    |                  | 13          | Revised para. 5.8.1 to list AEM procedures.   |                 |
|                    |                  | 15          | Revised para. 5.8.8 and 5.8.9.  |                 |
|                    |                  | 16          | Revised para. 5.8.13 added Group C.   |                 |
|                    |                  | 21          | Revised Flow Chart to follow MIL-PRF-23419/12.  |                 |

|              |   |                              |                |
|--------------|---|------------------------------|----------------|
| AEM, Inc.    | 11525 SORRENTO VALLEY RD<br>SAN DIEGO, CA 92121-1306. | TITLE<br>P700L SPECIFICATION |                |
| NUMBER P700L | REVISION J  | ECN 2139                     | SHEET 21 of 23 |

## DOCUMENTATION CHANGE NOTICE

| <u>REV. LETTER</u> | <u>REV. DATE</u>  | <u>PAGE</u> | <u>CHANGE ITEM</u>  | <u>APPROVAL</u> |
|--------------------|---|-------------|---|-----------------|
| F                  | 10-12-98<br>ECN 2109  | 2           | Revised para. 3.1 added reference to P700L-R specification.   |                 |
|                    |   | 4           | Added para. 4.8.3 X-Ray Inspection.   |                 |
|                    |   | 8           | Revised Table II added X-Ray Inspection.  |                 |
|                    |   | 9           | Revised Table III changed order of testing.   |                 |
|                    |   | 11          | Revised Table V added: Overload Current (400%), Short Circuit Interrupt, and Resistance After Firing to Subgroup III.     |                 |
|                    |   | 14          | Added para. 5.8.5 X-Ray Inspection.   |                 |
|                    |   | 17          | Deleted the Note in para. 6.2 referring to SN96 solder being used internally.   |                 |
|                    |   | 18          | Revised Figure 1 - Internal solder to be SN 10/PB 88/AG 2.  |                 |
|                    |   | 19          | Revised Figure 2 - Internal solder to be SN 10/PB 88/AG 2.  |                 |
|                    |   | 21          | Revised Figure 5 - Added X-Ray Inspection, and Radiographic Review, Changed the order of Group B Inspection.              |                 |
|                    |   | 10          | Revised Table IV to indicate Number of Defective Allowed.   |                 |
|                    |   | 8           | Revised Table II to indicate Number of Defective Allowed.   |                 |
|                    |   | 12          | Revised Table VI to reference Figure 1 or 2. Corrected 250% Let Thru Energy ratings for fuses rated at 3/8 to 20 amperes. |                 |
|                    |   | 13          | Revised paragraph 5.8.1 (Deleted references to final assembly, marking and sealing operations).                           |                 |
|                    |   | G           | 4-11-00<br>ECN 2119   | All             |
| 3                  | Deleted reference to P600L-M Specification in para. 3.1.  |             |   |                 |
| 6                  | Revised para. 5.7.4 to allow for use of X-Ray and Visual rejects for Group B Inspection.                  |             |   |                 |
| 7                  | Revised Table II to reference MIL-PRF-23419 (previously referenced MIL-F-23419).                          |             |   |                 |
| 11                 | Revised Table VI to include P700L-125-XX part options.  |             |   |                 |
| 13                 | Revised para. 5.8.6 to specify 80% rated current at +125C (previously stated 75% rated current at +125C). |             |   |                 |
| 15                 | Revised para. 6.1 to list match set fuse requirements.  |             |   |                 |

|              |   |          |                              |
|--------------|---|----------|------------------------------|
| AEM, Inc.    | 11525 SORRENTO VALLEY RD<br>SAN DIEGO, CA 92121-1306. |          | TITLE<br>P700L SPECIFICATION |
| NUMBER P700L | REVISION J  | ECN 2139 | SHEET 22 of 23               |

## DOCUMENTATION CHANGE NOTICE

| <u>REV. LETTER</u> | <u>REV. DATE</u>    | <u>PAGE</u> | <u>CHANGE ITEM</u>   | <u>APPROVAL</u> |
|--------------------|---------------------|-------------|--|-----------------|
| G                  | 4-11-00<br>ECN 2119 | 17          | Revised Figure 1 to include minimum and maximum dimensions. Revised suggested pad layout.  |                 |
|                    |                     | 18          | Revised Figure 2 to include minimum and maximum dimensions. Revised suggested pad layout. Revised weight to specify 1.85 grams (previously stated 1.25 grams). |                 |
|                    |                     | 19          | Revised Figure 3 to indicate 80% rated current at +125C previously stated 75% rated current at +125C).   |                 |
| H                  | 3-12-01<br>ECN 2126 | 3           | Revised para. 4.2.1 to indicate that exposed copper shall not exceed 2% of total lead surface.   |                 |
|                    |                     | 11          | Added Note 4 to table VI to indicate that P700L with Internal solder of Sn10/Pb88/Ag2 should be ordered as P700LH.   |                 |
|                    |                     | 16          | Revised para. 6.2 to indicate case temperature limitation for standard P700L part type.  |                 |
|                    |                     | 16          | Added section 6.3 for operation in thermal cycled environments.  |                 |
|                    |                     | 17          | Revised Figure 1 – Internal solder to be Sn96/Ag 4. Added note to indicate that Sn10/Pb88/Ag2 can be used for internal solder with P700LH option.              |                 |
|                    |                     | 18          | Revised Figure 2 - Internal solder to be Sn96/Ag 4. Added note to indicate that Sn10/Pb88/Ag2 can be used for internal solder with P700LH option.              |                 |
| J                  | 3/04<br>ECN 2139    | 5           | Added para. 4.8.19 for 168-hour burn-in testing requirements.  |                 |
|                    |                     | 8           | Revised Table III (Group B) to include Subgroup II for 168-hour burn-in testing.   |                 |
|                    |                     | 15          | Added para. 5.8.20 for 168-hour burn-in test method.   |                 |
|                    |                     | 20          | Revised Figure 5 to include Thermal Shock and 168-Hour Burn-in Test as Subgroup II of Group B.   |                 |

|              |   |                              |                |
|--------------|---|------------------------------|----------------|
| AEM, Inc.    | 11525 SORRENTO VALLEY RD<br>SAN DIEGO, CA 92121-1306. | TITLE<br>P700L SPECIFICATION |                |
| NUMBER P700L | REVISION J  | ECN 2139                     | SHEET 23 of 23 |

# Mouser Electronics

Authorized Distributor

Click to View Pricing, Inventory, Delivery & Lifecycle Information:

[AEM:](#)

[P700L-72-5.0](#) [P700-L-72-1.5](#) [P700L-72-3.0](#)