

Thermal Circuit Protectors

Reliable, Cost-effective Circuit Protection



Transforming Customer Needs into Customer Solutions

At Carling Technologies, we do much more than manufacture electrical components. We engineer powerful solutions. Working closely with your product team, we can tailor switching and circuit protection solutions that meet your application needs — cost effectively.

Since our founding in 1920, there are few products we haven't turned on, fewer industries that haven't turned to us. With five ISO certified manufacturing locations and technical sales offices worldwide, Carling Technologies now ranks among the world's largest privately owned manufacturers of hydraulic/magnetic circuit breakers, thermal circuit protectors, electrical switches and assemblies, power distribution centers and electronic control systems. In regard to circuit protection, we lead the industry in delivering higher ratings in smaller packages. And what makes all our breakers especially attractive is their superior performance and reliability — both hallmarks of Carling Technologies .

We have over 2000 employees working through offices and manufacturing sites across the globe, providing engineered solutions to leading electronic and industrial OEMs in a variety of industries, including:

- Electronics (telecom, medical, computers, office automation)
- Industrial Controls
- Transportation (on/off road vehicles, trucks, buses, boats)
- Appliances
- Factory Automation

We look forward to helping you create safe, reliable products that exceed the tough demands of today's applications. You'll find our commitment to excellence consistently delivers "Quality by Design," our company's mission.

Our commitment to quality products begins with our investment in research and development. Not only does Carling have a team of highly-qualified engineers on staff, we equip them with the industry's most advanced computer-aided design tools.

Our engineering team will work closely with yours to advance your project from initial product concepts to final design and manufacturing. Using industry-leading CAD/CAM software, Carling engineers can evaluate multiple design alternatives as well as develop products, tooling and manufacturing processes concurrently. The result? Functionally superior, aesthetically pleasing products — produced faster and at a lower cost.

We can even share electronic files that can be easily incorporated into the rest of your design. Just one more reason you'll think of Carling as much more than an approved vendor, but rather as a proven partner.



Our automated call center system ensures that your calls are routed to the right Customer Care person for prompt attention. Our customer care personnel are technically trained to discuss your requirements and provide the advice and services you expect from Carling Technologies. Each member of the Carling Customer Care team is technically trained on our standard products, and Application Engineers are also available to answer your more advanced technical questions. In addition, Carling is proud to offer a global network of fully trained representatives and distributors, who are always ready to service you.



Carling Technologies' Products

Within this catalog, you'll find our current line of thermal circuit protectors, from 3 to 60 amps, which offer reliable, cost effective circuit protection. We also offer a comprehensive line of hydraulic/magnetic and equipment leakage circuit protection, electrical switches, electronic control systems and power distribution centers. For more information on our other products, please request one of the catalogs listed on the inside back cover of this catalog, or go to www.carlingtech.com.

How To Use This Catalog

Please refer to the Contents, located on this page, for the type of breaker required. Each breaker Series is located under an alphabetical code. Each code refers you to the specific pages covering an individual Series. Product features/specifications and dimensional drawings are provided to assist you with product selection.

Follow our easy step-by-step catalog number sequence to construct the circuit breaker, which meets your needs. An ordering format and an example for constructing a catalog number are provided for each Series.

www.carlingtech.com

Our website also offers a fast and easy way for you to view product pages and pdf files for your thermal circuit protection needs. A stock check feature is also included at www.carlingtech.com. Product pages & PDF files make the Carling Technologies' web site your "one stop shop" for quick and thorough product information.

Customer Care Center

For additional application assistance, we urge you to consult with our experienced staff in our Customer Care Center. Our Technical and Engineering staff has extensive test, research and development capabilities, and have assisted many customers in solving unique design and application problems with standard or customized products. Please refer to our location listing on the back of this catalog, for contact information for your area.

We look forward to working with you.

Contents

	Page
Introduction	2
Available Choices of Circuit Protection	2
Product Specifications & Ordering Information	
CTB-Series Panel Mount Rocker Thermal Circuit Protector, Ratings up to 16A AC/DC	3
CMB-Series Miniature Pushbutton Thermal Circuit Protector, Ratings up to 20A AC/DC	4
CLB-Series Pushbutton Thermal Circuit Protector, Ratings up to 60A AC/DC	6
Regulatory Agencies	8

Warranty Policy

Carling Technologies, Inc. (Seller) warrants that goods sold hereunder shall be free of defects in material and workmanship for one year from date of shipment. In the event of such defects, the Seller's only obligation shall be the replacement or the cost of the defective goods, themselves, excluding, without limitation, labor costs, which are or may be required in connection with the replacement or reinstallation of the goods. This warranty is the Seller's sole obligation and excludes all other remedies or warranties, express or implied, including warranties of merchantability and fitness for a particular purpose, whether or not purposes or specifications are described herein. This Warranty expressly excludes any and all incidental, special and/or consequential damages of any nature. Seller further disclaims any responsibility for injury to person or damage to or loss of property or value caused by any product which has been subjected to misuse, negligence, or accident; or misapplied, or modified or repaired by a person or persons not authorized by the Seller or which have been improperly installed.

Any electrical or electronic equipment that is designed without including circuit protection is an accident waiting to happen. Under normal operating conditions, this may not appear to be a problem. However, normal operating conditions are not always guaranteed. Under strained or heavy use, a motor and/or another load-generating component within the equipment will draw additional current from the power source; when this happens, the equipment's wires and/or components will overheat and may ultimately burn up. Also, power surges and short circuits in unprotected equipment can cause extensive damage to the equipment and to the conductors leading to the equipment.

In addition to protecting the equipment, the entire electrical system including the control switches, wires, and power source must be protected from faults. A circuit protection device should be employed at any point where a conductor size changes. Many electronic circuits and components like transformers have a lower overload withstand threshold level than conductors such as wires and cables. These components require circuit protection devices featuring very fast overload sensing and opening capabilities.

Specifying a circuit protection device for an application is not a difficult task, but it will require some thought. If electrical and electronic equipment is designed with over-specified circuit protection devices they will be vulnerable to the damaging effects of power surges and the catastrophic results of a fire; while using under-specified circuit protection devices will result in nuisance tripping.

The short circuit capacity of a circuit protection device should be greater than the circuit's available short circuit fault current. Available short circuit current is the maximum RMS current that would be present if all the conductors were to be connected directly to the fault location. In reality, this is not the case. The actual short circuit current is much less than the available short circuit current. The actual short circuit current is reduced due to the combined impedance of the conductors, the size of the transformer and other current restricting components within the circuit.

The application's environmental conditions must be considered when selecting the proper circuit protection device. Excessive temperature, humidity, severe vibration and shock can cause adverse performance characteristics in many types of circuit protection devices. For instance, a fuse element is less reliable when it is hot than when it is cold.

Available Choices of Circuit Protection

Carling Technologies offers three types of circuit protection devices: thermal circuit protectors, hydraulic/magnetic circuit protectors/breakers and equipment leakage circuit breakers. This catalog features our thermal circuit protection product line. For details related to hydraulic/magnetic circuit protection and equipment leakage circuit breaker products, please see our Circuit Protection 403 catalog.

Thermal circuit protectors utilize a bimetallic strip electrically in series with the circuit. The heat generated by the current during an overload deforms the bimetallic strip and trips the breaker. Thermal protectors have a significant advantage over fuses in that they can be reset after tripping. They can also be used as the main ON/OFF switch for the equipment being protected.

Hydraulic/magnetic circuit protectors/breakers provide highly precise, reliable and cost effective solutions to most design problems. The hydraulic/magnetic circuit breaker is considered to be temperature stable and thus is not appreciably affected by changes in ambient temperature. Its over-current sensing mechanism reacts only to changes of current in the circuit being protected. It has no "warm-up" period to slow down its response to overload. It has no "cool-down" period after overload before it can be reset. The characteristics of a

hydraulic/magnetic circuit breaker can be tailored in four separate areas: the desired circuit; the trip point (in amperes); the time delay (in seconds); and the inrush handling capacity of the breaker. These factors can be varied with relatively little impact on the short circuit capability of the breaker. Typically, hydraulic/magnetic circuit breakers are available with a choice of three different trip time, delay curves: slow, medium and long. These choices provide the designer with a high level of design flexibility when matching the breakers trip time delay curves to other circuit protection devices in a cascade, or discriminating circuit. In addition, special hi-inrush constructions are available for equipment with severe inrush characteristics.

Equipment leakage circuit breakers function as hydraulic/magnetic circuit breakers, offering customized overload and short circuit protection. In addition, they sense and guard against faults to ground using innovative electronics technologies. With the exception of small amounts of leakage, the current returning to the power supply will be equal to the current leaving the power supply. If the difference between the current leaving and returning through the earth leakage circuit breaker exceeds the leakage sensitivity setting, the breaker trips and its LED illuminates. The LED gives a clear indication that the trip occurred as a result of leakage to ground. This protection helps prevent serious equipment damage and fire.

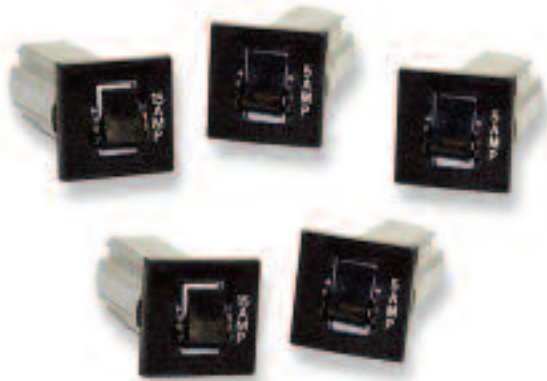

Rating:
3 to 16A, 125, 250VAC, 50VDC
Approvals:
UL, CUL, VDE, CE
Interrupting capacity:
1000 amps
Insulation Resistance:
100M ohms
Applications:
Household Appliances
Transportation
Marine
Power Strips
Medical Equipment
Audio Visual Equipment
Power Supplies
Exercise Equipment
ROHS Compliant

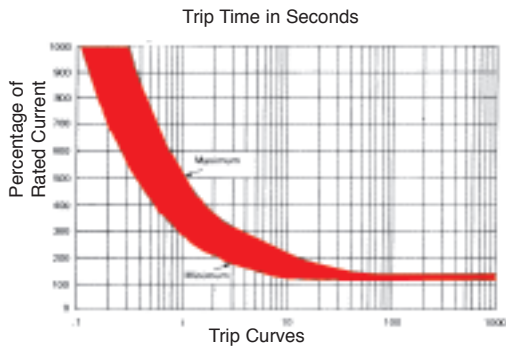

CORRECTION FACTOR ¹	
0°C	x .67
10°C	x .72
15°C	x .83
18°C	x .87
25°C	x 1.00
32°C	x 1.05
40°C	x 1.18
50°C	x 1.33
60°C	x 1.67

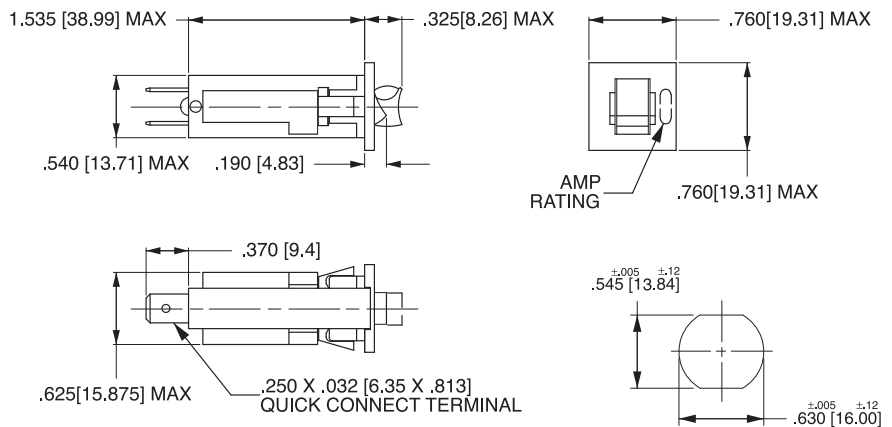

RECOMMENDED PANEL THICKNESS:
.032 - .062 [.81-1.57]

DOUBLE D MOUNTING

1. To adjust the breaker rating for ambient temperature, multiply the breaker rating by the factor. (ex: 5A rating x .850 = 4.25A. Select 4A rating.)

CTB - **B** - **B** - **05** - **B**

1 Series

2 Bezel Color

3 Rocker Color

4 Rating

5 Panel Thickness

1 SERIES
CTB

2 BEZEL COLOR¹
B Black

3 ROCKER COLOR¹
B Black

4 RATING

03 3 amp	08 8 amp	14 14 amp
04 4 amp	09 9 amp	15 15 amp
05 5 amp	10 10 amp	16 16 amp
06 6 amp	12 12 amp	
07 7 amp	13 13 amp	

5 PANEL THICKNESS

blank fits standard thickness of .032 - .062
B fits .070 - .110 panel thickness

NOTES:

All dimensions are in inches [millimeters].
 Tolerance ±.005 [.127] unless otherwise specified.
 Breaker must hold 100% of rated current and must trip at 150% and above, within the time limits shown in curve.
 Trip times specified at 25° ambient with no preloading.
¹ Additional colors available. Consult factory.



Rating:
3 to 20A, 125-250VAC, 32VDC

Approvals:
UL, CUL, CSA, TUV, CE
UL1500/ISO8846 for ignition protection/marine

Dielectric Strength:
2500 VAC/ 1 minute

Interrupting capacity:
2500 amps

Insulation Resistance:
100M ohms

Operating Temperature:
-10°C to 60°C

Voltage drop:
< 0.25 V

Applications:
Household Appliances
Transportation
Marine
Power Strips
Medical Equipment
Audio Visual Equipment
Power Supplies

ROHS Compliant

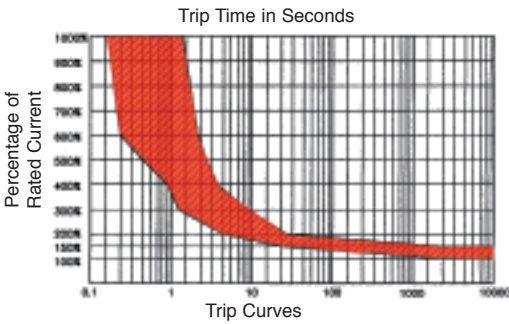

CORRECTION FACTOR ¹	
0°C	x .67
10°C	x .72
15°C	x .83
18°C	x .87
25°C	x 1.00
32°C	x 1.05
40°C	x 1.18
50°C	x 1.33
60°C	x 1.67

OVERLOAD	TRIP TIME
100%	NO TRIP
150%	TRIP IN 1 HR.
200%	4 - 40 SEC.
300%	1.2 - 12 SEC.
400%	0.5 - 5.5 SEC.
500%	0.4 - 3.5 SEC.
600%	0.3 - 2.5 SEC.

Breaker must hold 100% of rated current and must trip at 150% and above, within the time limits shown in curve. Trip times specified at 25° ambient with no preloading.
1. To adjust the breaker rating for ambient temperature multiply the breaker rating by the factor. (ex: 5 amp rating at 0°C: 5 x .67 = 3.3 amp. Select 3 amp rating.)

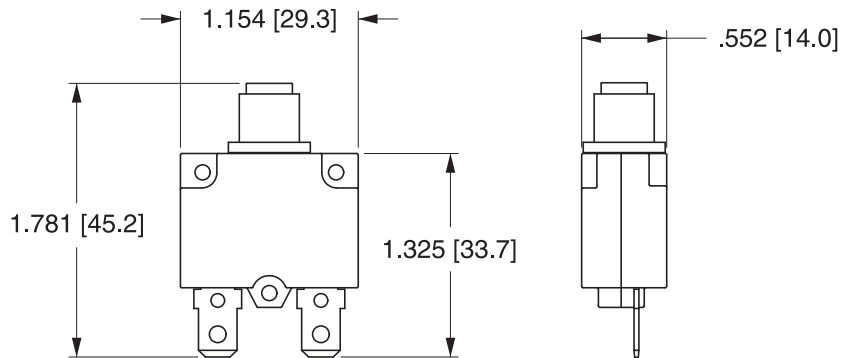

CMB - 10 3 - 11 C 3 B - B - A /10

1 Series 2 Rating 3 Voltage 4 Mounting Hole 5 Bushing Type 6 Mounting Nut 7 Indicator Plate 8 Button 9 Terminal 10 Button Marking

1 SERIES
CMB

2 RATING

03	3 amp	05	5 amp	07	7 amp	10	10 amp	13	13 amp	15	15 amp	20	20 amp
04	4 amp	06	6 amp	08	8 amp	12	12 amp	14	14 amp	16	16 amp		

3 VOLTAGE

3	125-250VAC/ 32 VDC
---	--------------------

4 MOUNTING HOLE

11 ¹	M11		M12		Snap-in Style	3/8-27	3/8-27 K BUSHING ONLY
12 ²	M12						
00 ³	Snap In Style						
27 ⁹	3/8" 27 UNS						
28 ¹²	3/8" 27 UNS (double flatted)						

5 BUSHING

PLASTIC C ⁴ Type C D ⁴ Type D E ⁵ Type E G ⁸ Type G H ⁶ Type H K ¹³ Type K METAL J ⁸ Type J	PLASTIC						METAL
	TYPE C	TYPE D	TYPE E	TYPE H	TYPE G	TYPE K	TYPE J

6 MOUNTING NUT⁷

N	None	METAL		METAL PAL	PLASTIC		HEX BOOT
1	Type 1						
2	Type 2						
3 ¹¹	Type 3						
4	Type 4						
5	Type 5						
6 ¹⁴	Type 6						
7 ⁹	Type 7						
8 ⁹	Type 8						

NOTE: Type 5 is clear hex boot. Type 8 is black hex boot (available for bushings E & J only); Type 3 nut includes molded in "PRESS TO RESET" marking.

7 INDICATOR PLATE⁷

N	None	Embossed (ALUMINUM)	Silver Printing On Black
A	Embossed		
B	Silver Printing on Black		

All indicator plates are marked "circuit breaker press to reset".

8 BUTTON

B	Black	R	Red	W	White
---	-------	---	-----	---	-------

9 TERMINAL

A	Type A		Type B: Line Pin		Type C: Load Pin		Type D: 90° Bend		Type E: 90° Bend Backward	
B	Type B									
C	Type C									
D	Type D									
E	Type E									

NOTES:
 All dimensions are in [mm].
 Tolerance ±.005 [0.127] unless otherwise specified.
 1 Used with bushing C or D only.
 2 Used with H bushing only.
 3 Used with bushing E only.
 4 Used with M11 mounting hole only.
 5 Used with mounting hole 00 only.
 6 Used with M12 mounting hole only.
 7 All hardware available separately. Consult factory.
 8 Available with mounting hole 27 only.
 9 Available with G or J bushing only.
 10 Amp rating must match button marking (ex: 20 will be marked on the button of CMB-203-27G3N-W-A/20)
 11 Includes molded in "PRESS TO RESET" marking.
 12 Available with K bushing only.
 13 Available with mounting hole 28 only.
 14 Thickness is 3.0 mm, .118 in.

10 BUTTON MARKING (IF BLANK, NO MARKING.)¹⁰ Button Marking Orientation: line load

03	3 amp	05	5 amp	07	7 amp	10	10 amp	13	13 amp	15	15 amp	20	20 amp
04	4 amp	06	6 amp	08	8 amp	12	12 amp	14	14 amp	16	16 amp		



Rating:
3 to 60A, 125-250VAC, 32VDC

Approvals:
UL, CUL, CSA, TUV, CE
UL1500/ISO8846 for ignition protection/marine

Dielectric Strength:
2500 VAC/ 1 minute

Interrupting capacity:
2500 amps

Insulation Resistance:
100M ohms

Operating Temperature:
-10°C to 60°C

Voltage drop:
< 0.25 V

Applications:
Household Appliances
Transportation
Marine
Power Strips
Medical Equipment
Audio Visual Equipment
Power Supplies

ROHS Compliant

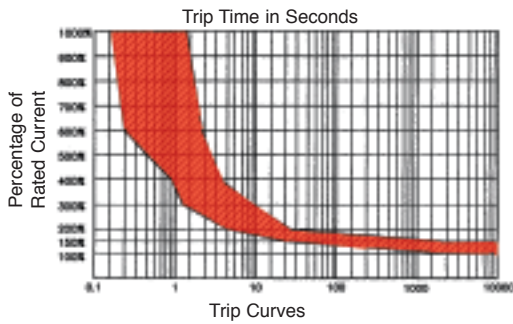

CORRECTION FACTOR ¹	
0°C	x .67
10°C	x .72
15°C	x .83
18°C	x .87
25°C	x 1.00
32°C	x 1.05
40°C	x 1.18
50°C	x 1.33
60°C	x 1.67

OVERLOAD	TRIP TIME
100%	NO TRIP
150%	TRIP IN 1 HR.
200%	5 - 35 SEC.
300%	1.5- 9 SEC.
400%	0.9 - 5.5 SEC.
500%	0.5 - 3.5 SEC.
600%	0.3 - 2.8 SEC.

Breaker must hold 100% of rated current and must trip at 150% and above, within the time limits shown in curve. Trip times specified at 25° ambient with no preloading.
 1 To adjust the breaker rating for ambient temperature multiply the breaker rating by the factor. (ex: 5 amp rating at 0°C: 5 x .67 = 3.3 amp. Select 3 amp rating.)

3-40A Construction

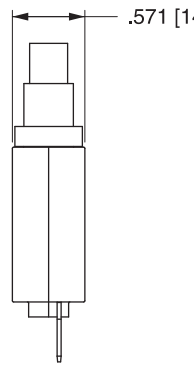
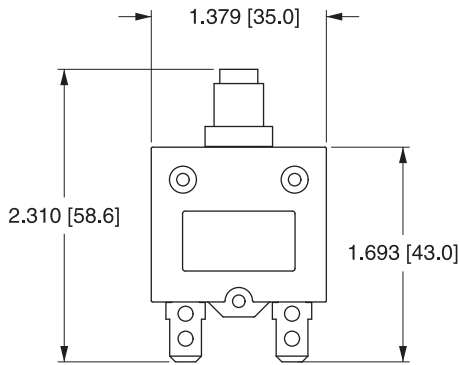

50 & 60A Construction

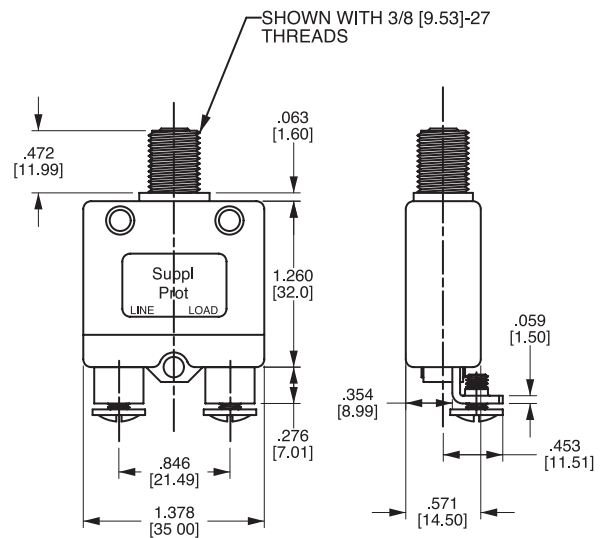

Ordering Scheme

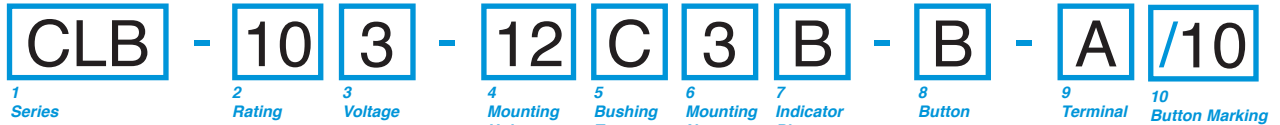

1 SERIES
CLB

2 RATING¹⁰

03 3 amp	05 5 amp	07 7 amp	10 10 amp	13 13 amp	18 18 amp	25 25 amp	35 35 amp	NEW 50 ¹⁵ 50 amp 60 ¹⁵ 60 amp
04 4 amp	06 6 amp	08 8 amp	12 12 amp	15 15 amp	20 20 amp	30 30 amp	40 40 amp	

3 VOLTAGE
3 125-250VAC/ 32 VDC

4 MOUNTING HOLE

<p>11¹ M11 12² M12 00³ Snap In 27⁴ 3/8 " 27 UNS</p>			<p>Panel Cutout Thickness: [0.8] - [2.5]mm .032-.098</p>	
	M 11	M12	Snap-in Style	3/8-27 UNS

5 BUSHING

	METAL				PLASTIC	
<p>METAL A⁵ Type A B⁶ Type B J⁸ Type J PLASTIC C⁵ Type C D⁷ Type D E⁸ Type E</p>						
	TYPE A	TYPE B	TYPE J	TYPE C	TYPE D	TYPE E

6 MOUNTING NUT⁹

	METAL	METAL PAL	PLASTIC	HEX BOOT
<p>N None 1 Type 1 2 Type 2 3 Type 3 4 Type 4</p>				
<p>5 Type 5 6^{12,15} Type 6 7¹² Type 7 8¹² Type 8</p>				
	TYPE 1	TYPE 2 / TYPE 6	TYPE 3	TYPE 5 / TYPE 8

NOTE: Type 5 is clear hex boot. Type 8 is black hex boot (available for bushings E & J only); Type 3 nut includes molded in "PRESS TO RESET" marking.

7 INDICATOR PLATE⁹

	Embossed (ALUMINUM)	Silver Printing On Black
<p>N None A Embossed B Silver Printing on Black</p>		
	Embossed (ALUMINUM)	Silver Printing On Black

All indicator plates are marked "circuit breaker press to reset".

NOTES:
All dimensions are in. [mm].
Tolerance ±.005 [.127] unless otherwise specified.
1 Used with bushing A or B only.
2 Used with bushing C only.
3 Used with bushing D only.
4 Used with bushing E & J only.
5 Used with M12 mounting hole only.
6 Used with M11 mounting hole only.
7 Used with mounting hole 00 only.
8 Used with 27 mounting hole only.
9 All hardware available separately. Consult factory.
10 > 35 amp ratings must use solder joint to connect wire to non-screw type terminals.
11 Terminals are .040 [1.0] thickness for rating > 35, & .315 [8] thickness is for ratings < 35 amps.
12 Available with type E or J bushing only.
13 Available only with 10-24 unc. screw terms. (select type F, G, H, J only.)
14 Amp rating must match button marking (ex: "20" will be marked on the button of the CLB-203-27E3N-B-A/20)
15 Thickness is 3.0 mm, .118 in.

8 BUTTON

B Black	R Red	W White
---------	-------	---------

9 TERMINAL^{10,11}

<p>A Type A B Type B C Type C D Type D E Type E F Type F G Type G H Type H J Type J</p>									
	.250 Tab	.126 [3.2]	.126 [3.2]	.126 [3.2]	.126 [3.2]	.250 Tab	.250 Tab	.250 Tab	.250 Tab
	Type A: Straight	Type B: Line Pin	Type C: Load Pin	Type D: 90° Bend	Type E: 90° Bend Backward	Type F: Screw Terminal	Type G: Mixed Terminals 90° Bend Load	Type H: Screw Terminal 90° Bend	Type J: Screw Terminal 90° Bend

10 BUTTON MARKING¹⁴ (IF BLANK, NO MARKING.) Button Marking Orientation:

line	(15)	load						
03 3 amp	05 5 amp	07 7 amp	10 10 amp	13 13 amp	18 18 amp	25 25 amp	35 35 amp	50 50 amp
04 4 amp	06 6 amp	08 8 amp	12 12 amp	15 15 amp	20 20 amp	30 30 amp	40 40 amp	60 60 amp

Most countries have regulatory agencies that determine the safety and performance standards required for products used in that country. Carling Technologies' circuit breakers are tested and have been certified by the most widely recognized of these agencies including Underwriters Laboratories (UL) in the United States; Canadian Standards Association (CSA) in Canada; TUV Rheinland/Berlin-Brandenburg (TUV) and Verband Deutscher Elektrotechniker (VDE) in Germany.

UL Recognized/UL1077 Recognized

UL Recognition covers components, which are incomplete or restricted in performance capabilities. These components will later be used in complete end products or systems Listed by UL. These Recognized components are not intended for separate installation in the field, they are intended for use as components of complete equipment submitted for investigation to UL.

Carling Technologies offers circuit breakers which are classified as supplementary circuit protectors and are Recognized under the UL Components Recognition Program as Protectors, Supplementary, UL Standard 1077. A UL 1077 Recognized supplementary circuit protector must have a Listed overcurrent device as a "back up".

UL Listed/UL 489 Listed

UL Listing indicates that samples of the circuit breaker as a complete product have been tested by UL to nationally recognized safety standards and have been found to be free from reasonably foreseeable risks of fire, electric shock and related hazards, and that the product was manufactured under UL's Follow-Up Services program.

Carling Technologies offers branch circuit breakers that are UL 489 Listed. Branch circuit breakers are classified as a final overcurrent device dedicated to protecting the branch circuit and outlet(s). They do not require an additional "back up" overcurrent device wired in series to protect a circuit. Carling's C, E and F-Series circuit breakers offer UL489 Listing. In addition, they are UL489A Listed for the Telecom industry.

UL1500 (MARINE)

UL1500 refers to products and components classified as ignition-protected, and are intended to be installed and used in accordance with applicable requirements to the U.S. Coast Guard, the Fire Protection Standard for Pleasure and Commercial Motor Craft, ANSI/NFPA No. 302, and the American Boat and Yacht Council, Incorporated.

CSA

The CSA (Canadian Standards Association) is the closest in concept and nature to UL of any group outside of the United States. Their standards and requirements are often almost identical to corresponding UL standards. CSA publishes their standards for most circuit protection devices as separate sections of CSA Standard C22.2 that in turn, forms a part of the Canadian Electrical Code.

CUL

A CUL mark on a product means that samples of the product have been evaluated to the applicable Canadian standards and codes by Underwriters Laboratories Inc.

VDE and TUV

There are two German government approved independent agencies, VDE (Verband Deutscher Elektrotechniker), and TUV (Technischer Überwachungs-Verein). In the circuit protection field, outside of the U.S.A. and Canada, VDE is the best known certification mark. VDE testing facilities are located in Germany.

TUV also performs testing and grants certification in accordance to the IEC/EN specifications. TUV's organization is made up of at least eleven geographically dispersed companies. At least two are located in the United States. This aids some U.S. manufacturers in getting "fast track" approval to a IEC/EN specifications.

CE MARKING

The European Union's (EU) approach to create single market access is based on four principles: harmonized directives, harmonized standards, harmonized conformity assessment procedures and CE marking. The CE marking is affixed to products indicating that the product conforms to relevant directives and standards. Various directives and standards contain the requirements for the CE marking. The CE marking is primarily for market control by custom inspectors.

Before a manufacturer can affix the CE marking to their product they must complete the following steps:

1. Identify the applicable EU directive/standard
2. Perform the conformity assessment according to the applicable EU directive/standard
3. Establish a Technical File containing test reports, documentation, certificates, etc.
4. Prepare and sign a EU Declaration of Conformity

Many of Carling Technologies' circuit protection products are available with CE marking indicating conformance to Low Voltage Directive 73/23/EEC.



ONLINE

carlingtech.com

Our extensive web site provides in-depth, detailed information about our products and capabilities. And with offices around the world, we're always ready to do business, answer questions and help our customers. Call, fax or e-mail anytime to start working with a company that's always **ON**.

World-Wide
Corporate Headquarters
Carling Technologies, Inc.
60 Johnson Avenue
Plainville, CT 06062
860/793-9281
FAX: 860/793-9231
E-mail: info@carlingtech.com
www.carlingtech.com

Carling Technologies
Europe/Middle East/Africa
Carling Technologies Ltd.
Devon, England
Int + 44 (0)1392-364422
FAX: Int + 44 (0)1392-364477
E-mail: lt-sales@carlingtech.com

Carling Technologies
Asia/Pacific
Carling Technologies Asia-Pacific Ltd.
Kowloon, Hong Kong
Int + 852-2737-2277
FAX: Int + 852-2736-9332
E-mail: sales@carlingtech.com.hk

Additional Carling Technologies Offices
East Region Sales Office, CT
ersm@carlingtech.com
Midwest Region Sales Office, IL
mrsm@carlingtech.com
West Region Sales Office, CA
wrsm@carlingtech.com
GmbH, Germany
gmbh@carlingtech.com
SARL, France,
sarl@carlingtech.com
Asia-Pacific Ltd., Shanghai, China
capsh@online.sh.cn
Asia-Pacific Ltd., Japan
japan@carlingtech.com
Pune, India
india@carlingtech.com

