

Features

- Independent 2-channel H-bridge drivers built-in power PMOS and NMOS.
- All the drivers with forward, reverse, stop and brake function.
- Low stand-by and operating current.
- Low on-resistance. (1.0Ω)
- Low voltage operation.
- Built-in thermal shutdown function.
- Package PDIP-16 & SOP-14

General Description

The AT5562 is a 2-channel H-bridge drivers IC for DC motor application. It has the features of low stand-by current, low operating current, large current output and low RDSON. Those features make it suitable for toy.

Applications

- Toy motor Driver

Block Diagram

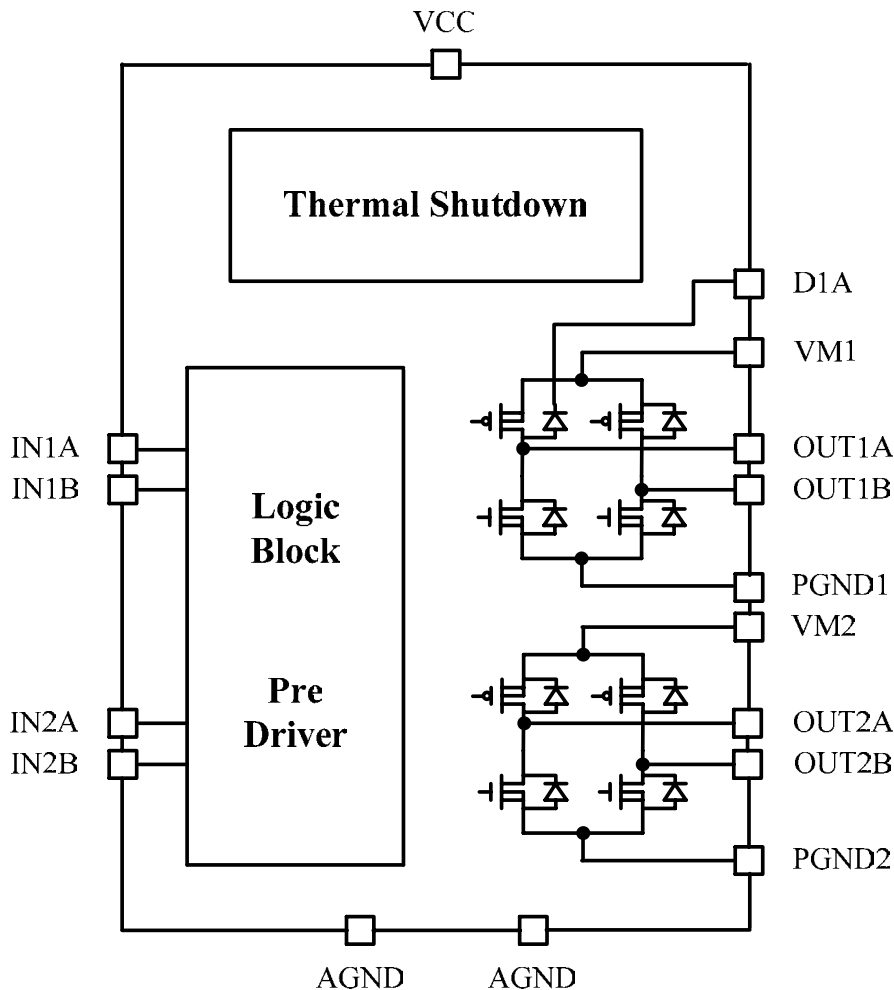

Aimtron reserves the right without notice to change this circuitry and specifications.

Pin Configuration

DIP-16

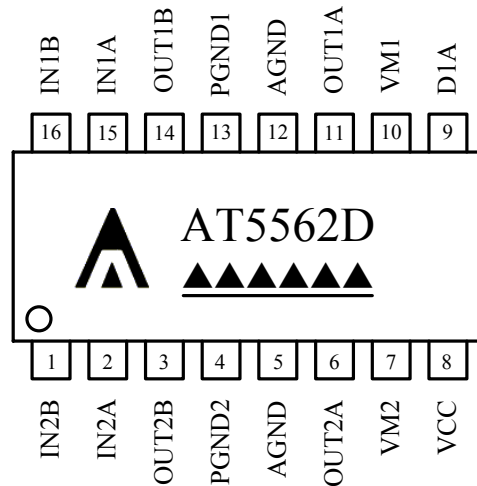

SOP-14

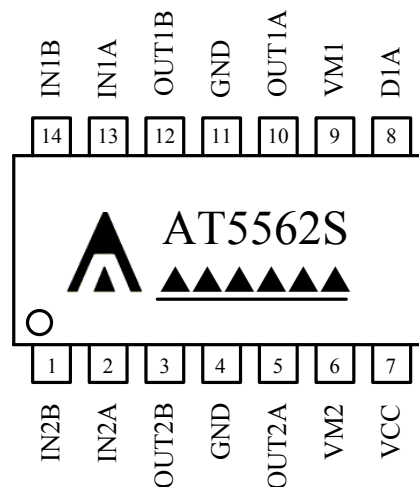

Ordering Information

Part number	Package	Marking
AT5562D_PBF	PDIP-16,PB-Free	▲▲▲▲▲▲▲, Date Code with one bottom line
AT5562S_GRE	SOP-14, Green	▲▲▲▲▲▲▲, Date Code with one bottom line

*For more marking information, contact our sales representative directly

Pin Description

DIP-16

Pin NO.	Symbol	I/O	Description
1	IN2B	I	It combines IN2A to decide the state of the driver2
2	IN2A	I	It combines IN2B to decide the state of the driver2
3	OUT2B	O	H-bridge output terminal 2B of the driver2
4	PGND1	G	Power GND
5	AGND	G	GND
6	OUT2A	O	H-bridge output terminal 2A of the driver2
7	VM2	P	Power supply for driver2
8	VCC	P	Power supply
9	D1A	I	Cathode of upper diode in OUT1A. It must be connected to VM1 or higher power supply for turbo function.
10	VM1	P	Power supply for driver1
11	OUT1A	O	H-bridge output terminal 1A of the driver1
12	AGND	G	GND
13	PGND2	G	Power GND
14	OUT1B	O	H-bridge output terminal 1B of the driver1
15	IN1A	I	It combines IN1B to decide the state of the driver1
16	IN1B	I	It combines IN1A to decide the state of the driver1

SOP-14

Pin NO.	Symbol	I/O	Description
1	IN2B	I	It combines IN2A to decide the state of the driver2
2	IN2A	I	It combines IN2B to decide the state of the driver2
3	OUT2B	O	H-bridge output terminal 2B of the driver2
4	GND	G	GND
5	OUT2A	O	H-bridge output terminal 2A of the driver2
6	VM2	P	Power supply for driver2
7	VCC	P	Power supply
8	D1A	I	Cathode of upper diode in OUT1A. It must be connected to VM1 or higher power supply for turbo function.
9	VM1	P	Power supply for driver1
10	OUT1A	O	H-bridge output terminal 1A of the driver1
11	GND	G	GND
12	OUT1B	O	H-bridge output terminal 1B of the driver1
13	IN1A	I	It combines IN1B to decide the state of the driver1
14	IN1B	I	It combines IN1A to decide the state of the driver1

Absolute Maximum Ratings *1

Parameter	Symbol	Ratings	Unit
Supply voltage VCC	VCC	+5.5	V
Supply voltage VM	VM	+10.5	V
Control input voltage	VIN	VCC	V
D1A voltage	VD1A	VM+4.5	V
Power dissipation, Pd *2	DIP-16	2	W
	SOP-14	1.73	
Thermal Resistance from Junction to Ambient, θ_{JA} *2	DIP-16	65	°C/W
	SOP-14	75	
Operating temperature	Topr	-20 ~ +85	°C
Junction temperature	Tj	~ +150	°C
Storage temperature range	Tstg	-55 ~ +150	°C
Peak output current for 1 CH	Iop	1.5	A
Maximum continuous output current for 1CH *3	Ioc	0.8	A
ESD Susceptibility *4	HBM	2	KV
	MM	200	V

1. Stresses beyond those listed under “Absolute Maximum Ratings” may cause permanent damage to the device. These are stress ratings only, and functional operation of the device at these or any other conditions beyond those indicated in the operational sections of the specifications is not implied. Exposure to absolute maximum rating conditions for extended periods may affect device reliability.
2. The accuracy of θ_{JA} or power dissipation will be based on PC board layout.
3. The maximum continuous output current should be set due to be corresponding with the power dissipation.
4. Device are ESD sensitive. Handling precaution recommended. The Human Body model is a 100pF capacitor discharged through a 1.5K Ω resistor into each pin.

Recommended Operating Conditions

(Ta=25°C)

Parameter	Symbol	Ratings	Unit
Supply voltage VCC	VCC	+2.2 ~ +5.0	V
Supply voltage VM1,2	VM1,2	+1.8 ~ +9	V
Control input voltage	VIN	0 ~ VCC	V
D1A voltage	VD1A	VM ~ VM+3	V
H Bridge output current	Iout	-400 ~ +400	mA

Electrical Characteristic

(Ta=25 °C, VCC=3.0V, VM1=VM2=3V, R_{L1}=R_{L2}=15Ω, unless otherwise noted.)

Parameter	Symbol	Condition	Values			Unit
			Min.	Typ.	Max.	
Whole circuits						
Circuit current at standby	ICCST	IN1A=IN1B=IN2A=IN2B=L	--	0	10	uA
VM current at standby	IVMST	IN1A=IN1B=IN2A=IN2B=L	--	0	10	uA
Circuit current	ICC	INxA=H, INxB=L or INxA=L, INxB=H or INxA=H, INxB=H	--	0.3	1	mA
VM current	IVM	INxA=H, INxB=L or INxA=L, INxB=H or INxA=H, INxB=H No load	--	0.1	0.5	mA
Control input						
H level input voltage	VINH		2.0	--	--	V
L level input voltage	VINL		--	--	0.8	V
H level input voltage	IINH	VIN=3V	--	5	20	uA
L level input voltage	IINL	VIN=0V	-1	0	--	uA
Pull-down resistance	RIN		--	1.5	--	MΩ
Driver1, 2						
Output ON Resistance	RON	I _o =+/-200mA, Sum of on-resistance	--	1.00	1.60	Ω
Diode						
Leakage current	IDLEAK	VCC=5V, VM1=9V	--	--	100	uA
Spark-killing Diode voltage	VD	IO _{UT} =400mA	--	--	1.7	V
Thermal Protection Circuit						
Protection Temperature	TSD		--	150	--	°C

Input-output logic table

Input				Output				Mode
IN1A	IN1B	IN2A	IN2B	OUT1A	OUT1B	OUT2A	OUT2B	
L	L			Hi-Z	Hi-Z			Standby
H	L			H	L			Forward
L	H			L	H			Reverse
H	H			L	L			Brake
		L	L			Hi-Z	Hi-Z	Standby
		H	L			H	L	Forward
		L	H			L	H	Reverse
		H	H			L	L	Brake

Input-output waveforms

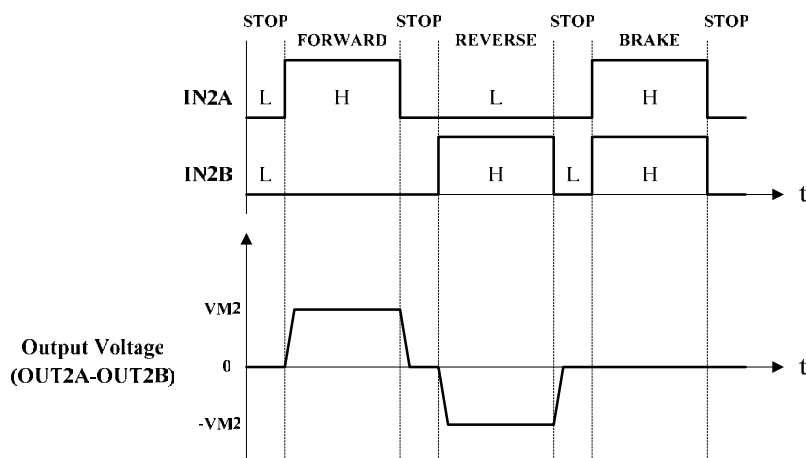
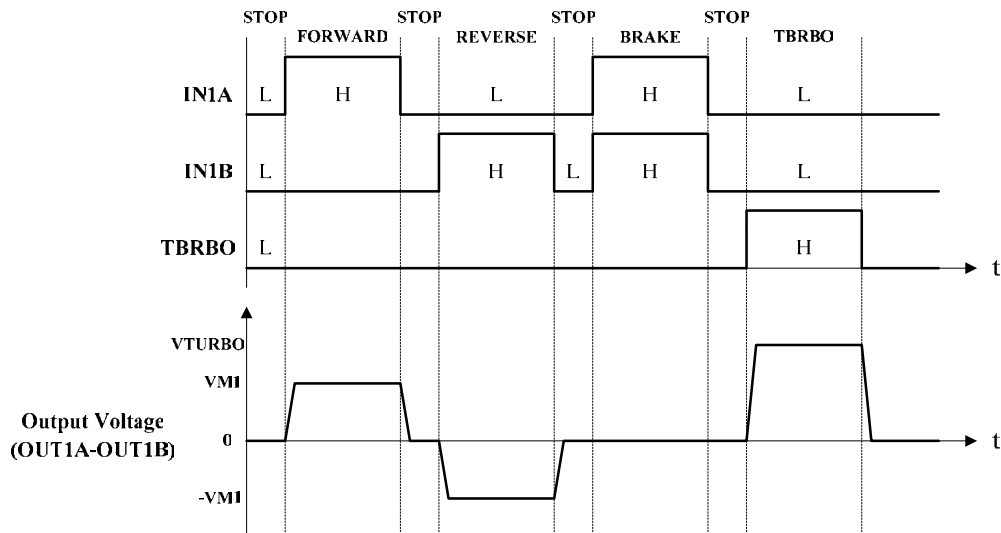

Application reference 1-1

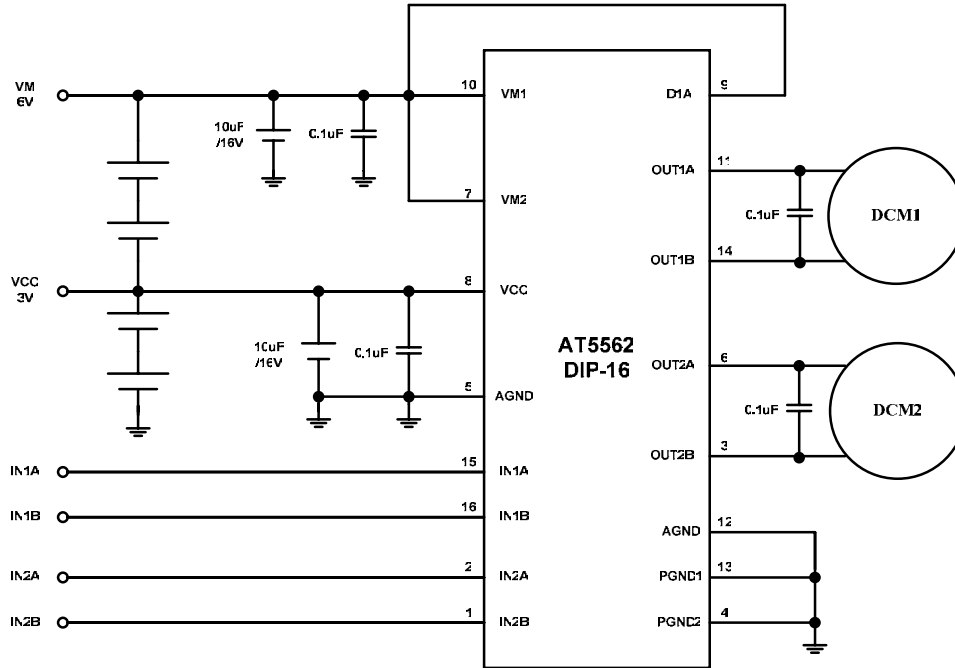

FIG. 1: DIP-16 package of AT5562 for typical application.

Application reference 1-2

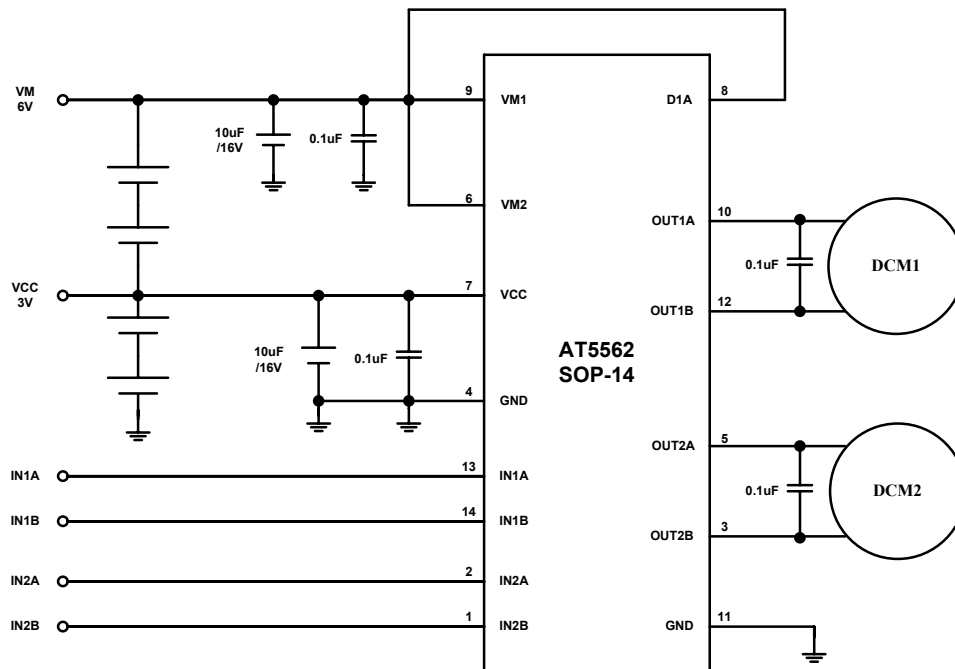

FIG. 2: SOP-14 package of AT5562 for typical application.

Application reference 2-1

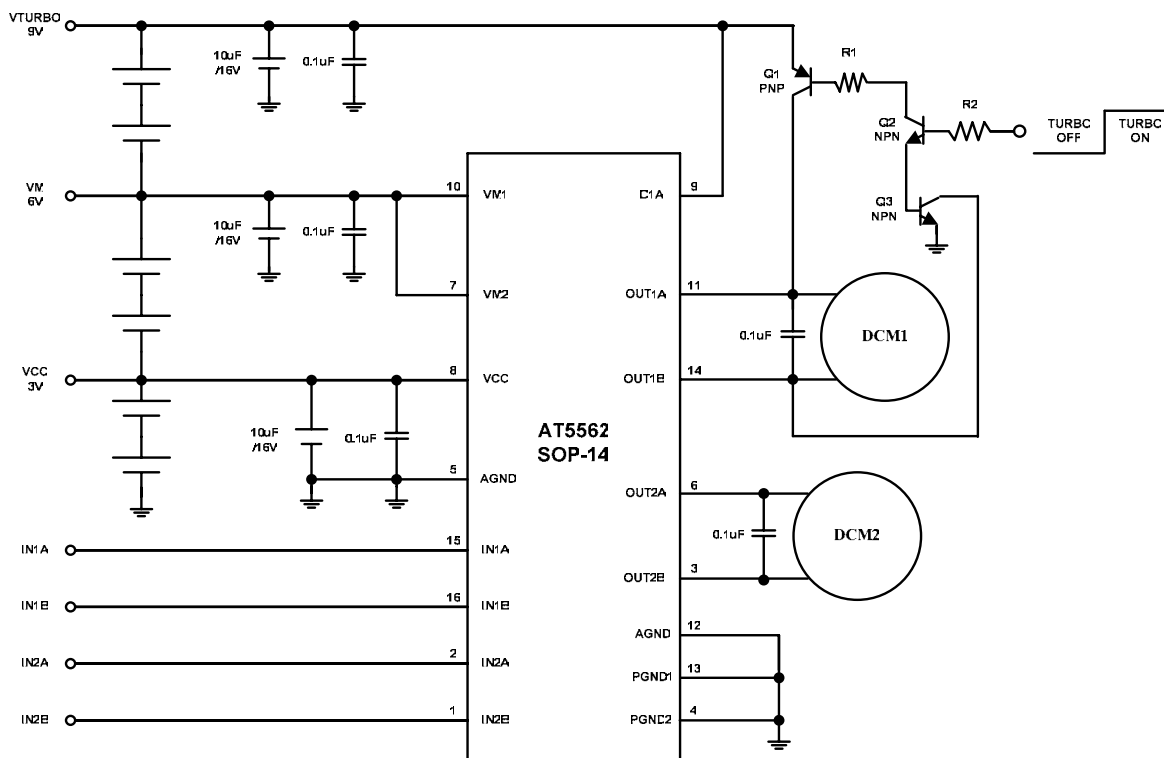
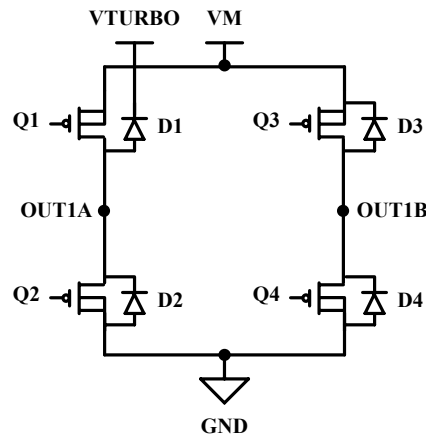

FIG. 3: DIP-16 package of AT5562 for application with a turbo function.

NOTED : To see below figure.

Because DCM 1 is operated with turbo function, D1A pin (pin 9) must be connected to voltage at VTURBO. The output current is essentially continuous due to inductor -characteristic of motor, so if DCM1 is operated in reverse-forward, the stop mode which will make AT5562 to turn off all switcher should not be the way to stop the DCM1. The brake mode which will make AT5562 turn on Q1 and Q3 is best way to stop motor in reverse-forward mode.



Application reference 2-2

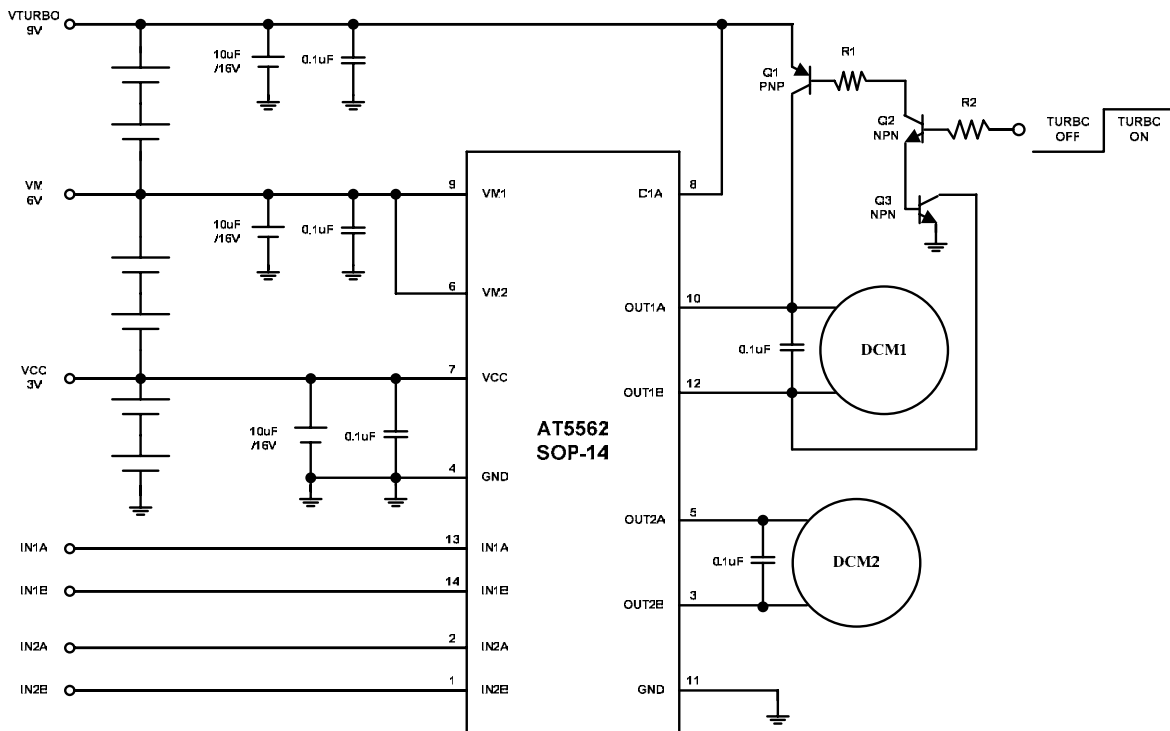
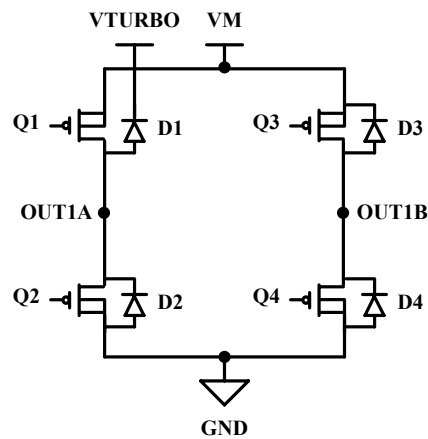

FIG. 4: SOP-14 package of AT5562 for application with a turbo function.

NOTED : To see below figure.

Because DCM 1 is operated with turbo function, D1A pin (pin 9) must be connected to voltage at VTURBO. The output current is essentially continuous due to inductor -characteristic of motor, so if DCM1 is operated in reverse-forward, the stop mode which will make AT5562 to turn off all switcher should not be the way to stop the DCM1. The brake mode which will make AT5562 turn on Q1 and Q3 is best way to stop motor in reverse-forward mode.



Package Description : DIP-16

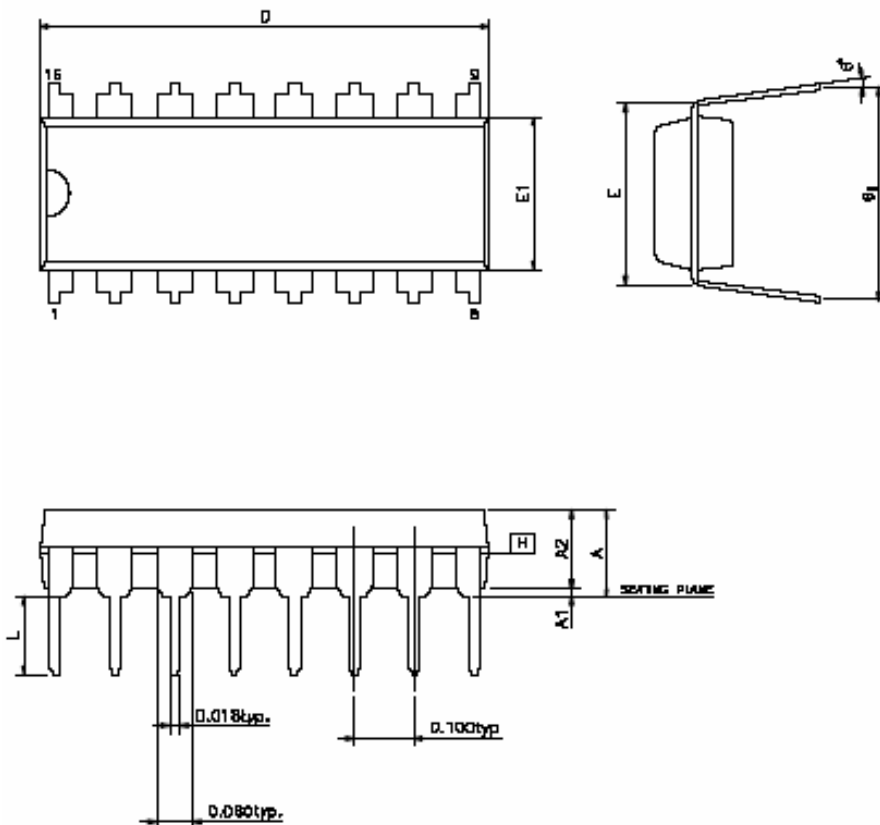

SYMBOLS	MIN.	NOR.	MAX.
A	—	—	0.210
A1	0.015	—	—
A2	0.125	0.130	0.135
D	0.735	0.755	0.775
E	0.300 BSC.		
E1	0.245	0.250	0.255
L	0.115	0.130	0.150
e _B	0.335	0.355	0.375
ϕ	0	7	15

UNIT : INCH

Package Description : SOP-14

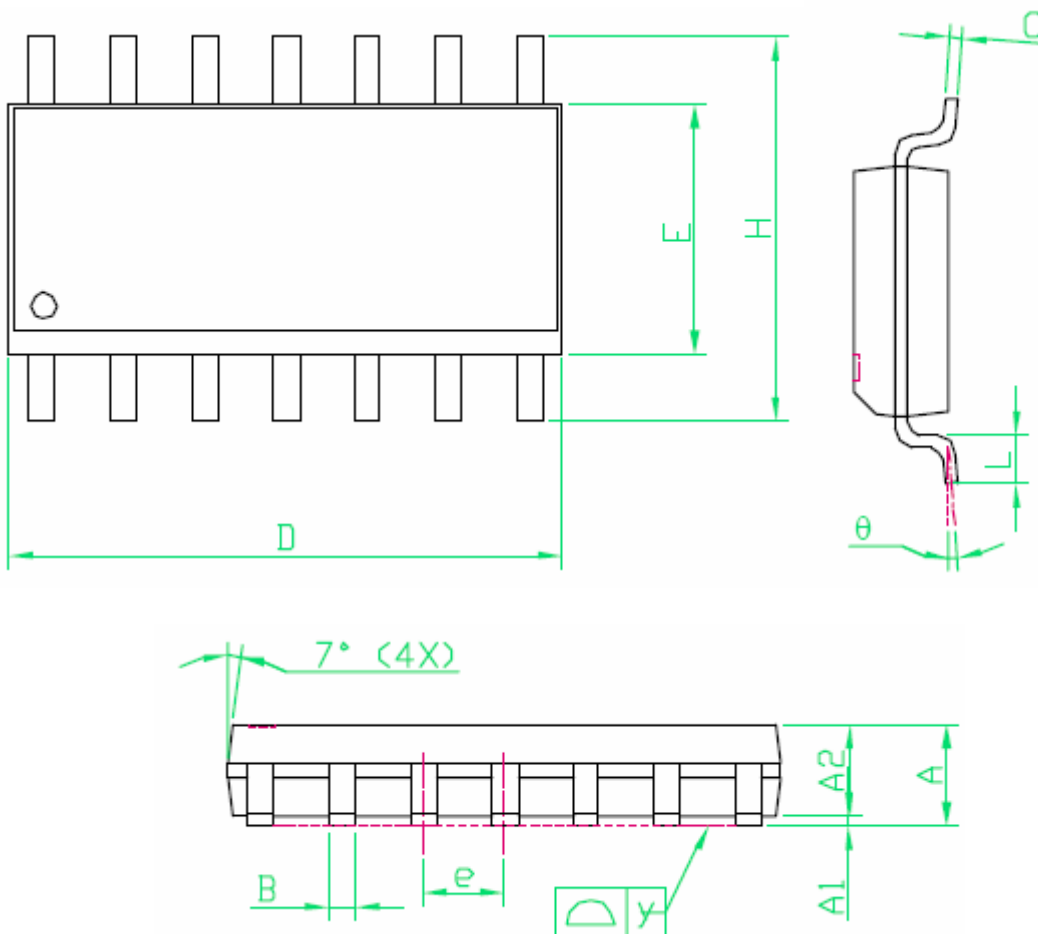

SYMBOLS	DIMENSIONS IN MILLIMETERS			DIMENSIONS IN INCHES		
	MIN	NOM	MAX	MIN	NOM	MAX
A	1.35	1.60	1.75	0.053	0.063	0.069
A1	0.10	---	0.25	0.004	---	0.010
A2	---	1.45	---	---	0.057	---
B	0.33	---	0.51	0.013	---	0.020
C	0.19	---	0.25	0.007	---	0.010
D	8.55	---	8.75	0.337	---	0.344
E	3.80	---	4.00	0.150	---	0.157
e	---	1.27	---	---	0.050	---
H	5.80	---	6.20	0.228	---	0.244
L	0.40	---	1.27	0.016	---	0.050
y	---	---	0.10	---	---	0.004
θ	0°	---	8°	0°	---	8°

Reflow Profiles

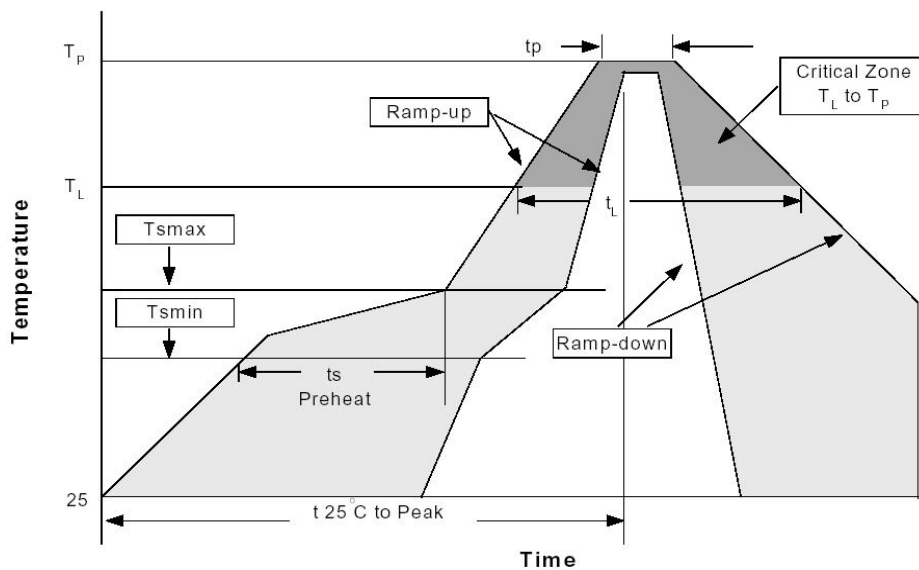

Profile Feature	Sn-Pb Eutectic Assembly		Pb-Free Assembly	
	Large Body Pkg. thickness ≥2.5mm or Pkg. volume ≥350mm ³	Small Body Pkg. thickness <2.5mm or Pkg. volume <350mm ³	Large Body Pkg. thickness ≥2.5mm or Pkg. volume ≥350mm ³	Small Body Pkg. thickness <2.5mm or Pkg. volume <350mm ³
Average ramp-up rate (T _L to T _P)	3°C/second max.		3°C/second max.	

Preheat				
-Temperature Min(Tsmin)	100°C		150°C	
-Temperature Max (Tsmax)	150°C		200°C	
-Time (min to max)(ts)	60-120 seconds		60-180 seconds	
Tsmax to TL			3°C/second max.	
-Ramp-up Rate				
Time maintained above:				
-Temperature (TL)	183°C		217°C	
-Time (tL)	60-150 seconds		60-150 seconds	
Peak Temperature(Tp)	225+0/-5°C	240+0/-5°C	245+0/-5°C	250+0/-5°C
Time within 5°C of actual Peak Temperature (tp)	10-30 seconds	10-30 seconds	10-30 seconds	20-40 seconds
Ramp-down Rate	6°C/second max.		6°C/second max.	
Time 25°C to Peak Temperature	6 minutes max.		8 minutes max.	

*All temperatures refer to topside of the package, measured on the package body surface.