

General Description

The AAT4295/97 SmartSwitch is a member of AnalogicTech's Application Specific Power MOSFET™ (ASPM™) product family. The AAT4295/97 is comprised of three/six low-side N-channel MOSFET switches that gate an applied load to ground. This device is intended for controlling RGB fashion lighting in portable products; it can also be used for a combination of general purposes where a load requires a low-side switch connection to ground. The AAT4295/97 simplifies design and layout limitations by eliminating the need for multiple GPIO control lines and discrete MOSFETs to control product features.

The state of each output channel is controlled with a single GPIO line via the EN/SET pin using AnalogicTech's Simple Serial Control™ (S²Cwire™) interface. After a short set of data pulses is sent to the EN/SET input and the line is pulled to logic high, the device is enabled with the desired switch configuration. In the enabled state, the AAT4295/97 typically consumes less than 3μA of quiescent current. When EN/SET is pulled to a logic low, the device is disabled and each output switch is placed in a high impedance open state.

The AAT4295 and AAT4297 operate over an input voltage range of 1.8V to 5.5V, making them ideal for battery-powered applications. The three-switch AAT4295 is offered in a Pb-free, 8-pin SC70JW package, while the six-switch AAT4297 is offered in a Pb-free, 12-pin TSOPJW package. Both devices are rated over the -40°C to +85°C temperature range.

Typical Application

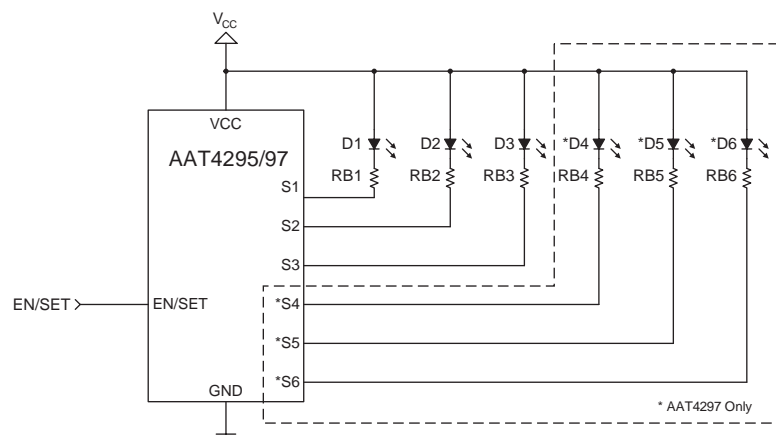

Features

- Input Voltage Range: 1.8V to 5.5V
- Independent Low-Side N-Channel MOSFET Switches:
 - AAT4295: Three Channels
 - AAT4297: Six Channels
- User-Programmable S²Cwire Interface
- Single GPIO Controls State of Each MOSFET
- Low Quiescent Current: 3μA Typical
- Temperature Range: -40°C to +85°C
- No External Components Required
- Available in Pb-Free Packages
 - AAT4295 in 8-Pin SC70JW
 - AAT4297 in 12-Pin TSOPJW

Applications

- Cell Phones
- Multiple Low Power Switching
- Personal Communication Devices
- Portable Electronic Devices

Pin Descriptions

Pin Number		Symbol	Function
AAT4295	AAT4297		
1	8	VCC	Input supply voltage.
2, 3	9, 10, 12	N/C	No connection.
4	11	EN/SET	Input control pin using S ² Cwire serial interface. The device records rising edges of the clock and decodes them into eight states, which control the ON/OFF states of the MOSFETs. See Table 1 for output settings. In addition, a logic low forces the device into shutdown mode, reducing the supply current to less than 1μA. This pin should not be left floating.
5	1	GND	Ground connection.
6	2	S1	Drain of the N-channel MOSFET for Channel 1.
7	3	S2	Drain of the N-channel MOSFET for Channel 2.
8	6	S3	Drain of the N-channel MOSFET for Channel 3.
N/A	4	S5	Drain of the N-channel MOSFET for Channel 5.
N/A	5	S4	Drain of the N-channel MOSFET for Channel 4.
N/A	7	S6	Drain of the N-channel MOSFET for Channel 6.

Pin Configuration

AAT4295
SC70JW-8
(Top View)

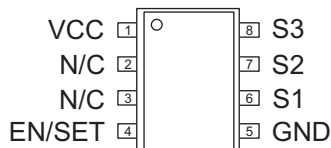

AAT4297
TSOPJW-12
(Top View)

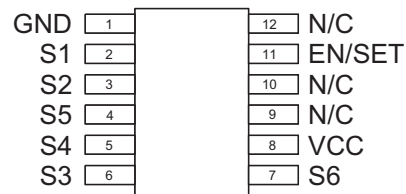

Absolute Maximum Ratings¹

Symbol	Description	Value	Units
V _{CC} to GND	Power Supply to GND	6.0	V
INx to GND	All Input (Drain) to GND	-0.3 to 6.0	V
EN/SET	EN/SET to GND	-0.3 to 6.0	V
T _J	Operating Junction Temperature Range	-40 to 150	°C

Thermal Information²

Symbol	Description	Value	Units
θ _{JA}	Thermal Resistance	SC70JW	225
		TSOPJW	160
P _D	Maximum Power Dissipation	SC70JW	440 ³
		TSOPJW	625 ⁴

1. Stresses above those listed in Absolute Maximum Ratings may cause permanent damage to the device. Functional operation at conditions other than the operating conditions specified is not implied. Only one Absolute Maximum Rating should be applied at any one time.
 2. Mounted on an FR4 board.
 3. Derated 4.4mW/°C above 25°C.
 4. Derated 6.25mW/°C above 25°C.

Electrical Characteristics¹

$V_{CC} = 5.0V$; $T_A = -40^{\circ}C$ to $+85^{\circ}C$, unless otherwise noted. Typical values are $T_A = 25^{\circ}C$.

Symbol	Description	Conditions	Min	Typ	Max	Units
V_{CC}	Supply Voltage Range		1.8		5.5	V
I_Q	Quiescent Current	$V_{CC} = 5V$, EN/SET = V_{CC} , $I_{OUT} =$ No Load, All Switches On		3.0	10	μA
$I_{Q(OFF)}$	Off Supply Current	EN/SET = 0, $V_{CC} = 5V$, V_{OUT} Open			1.0	μA
$I_{DS(OFF)}$	Off Switch Current for Any Switch	EN/SET = 0, $V_{CC} = 5V$, $V_{OUT} = 0$		0.1	1.0	μA
$R_{DS(ON)}$	On-Resistance	$V_{CC} = 5V$		1.9	6.0	Ω
		$V_{CC} = 3.6V$		2.1	7.0	
T_{CRDS}	On-Resistance Temperature Coefficient			2800		ppm/ $^{\circ}C$
T_{ON}	Output Turn-On Time ²	$V_{IN} = 5V$, $R_{PULLUP} = 250\Omega$, $C_{OUT} = 0.1\mu F$		0.6	2.7	μs
EN/SET						
$V_{EN(L)}$	Enable Threshold Low	$V_{IN} = 1.8V$			0.3	V
$V_{EN(H)}$	Enable Threshold High	$V_{IN} = 5.5V$	1.4			V
$T_{EN/SET LO}$	EN/SET Low Time		0.5		75	μs
T_{EN/SET_HL_MIN}	Minimum EN/SET High Time			50		ns
T_{EN/SET_HL_MAX}	Maximum EN/SET High Time				75	μs
T_{OFF}	EN/SET Off Timeout				500	μs
T_{LAT}	EN/SET Latch Timeout				500	μs
$I_{EN/SET}$	EN/SET Input Leakage		-1		1	μA

1. The AAT4295 is guaranteed to meet performance specifications over the $-40^{\circ}C$ to $+85^{\circ}C$ operating temperature range and is assured by design, characterization, and correlation with statistical process controls.

2. T_{ON} is the time after latch timeout to 10% of the output voltage. See Figure 1, Timing Diagram.

Typical Characteristics

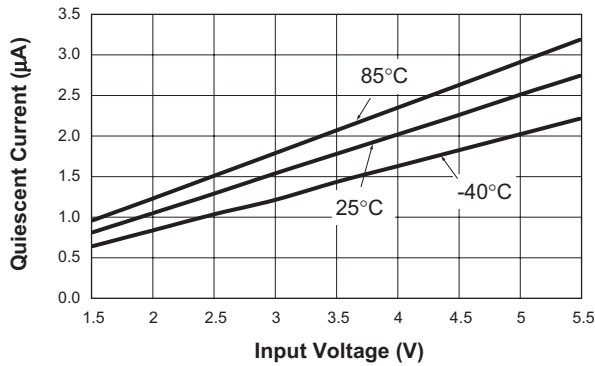
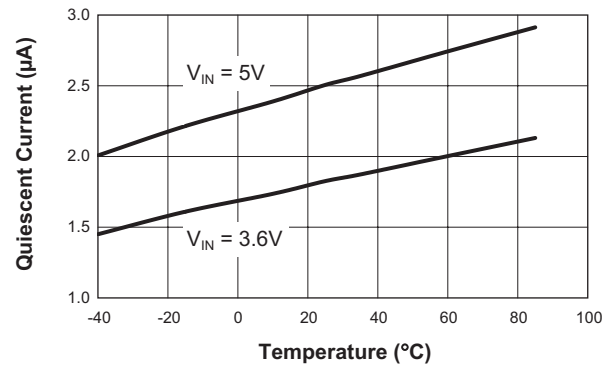
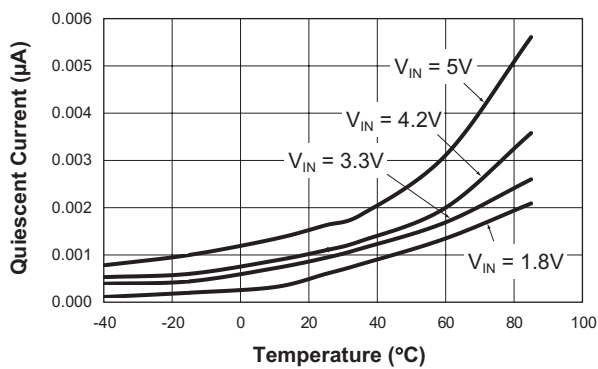
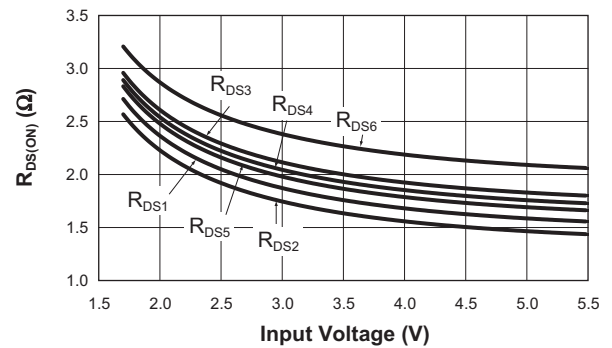
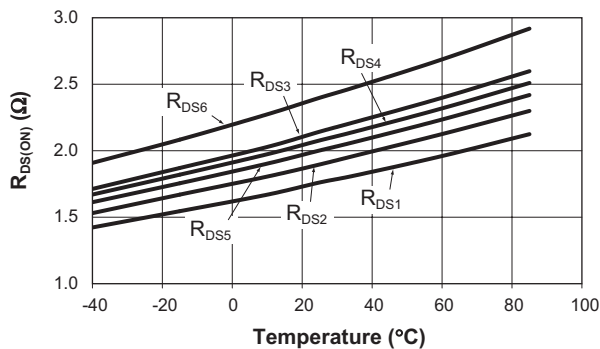
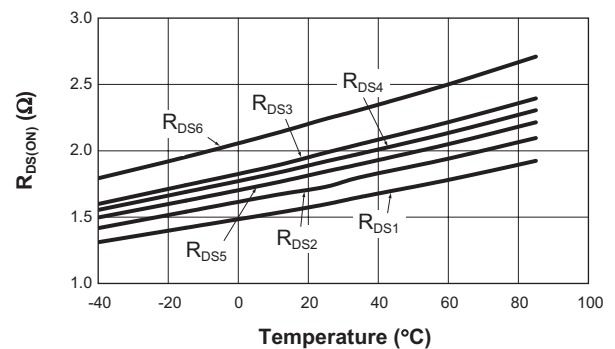
Quiescent Current vs. Input Voltage

Quiescent Current vs. Temperature

Off-Supply Current vs. Temperature

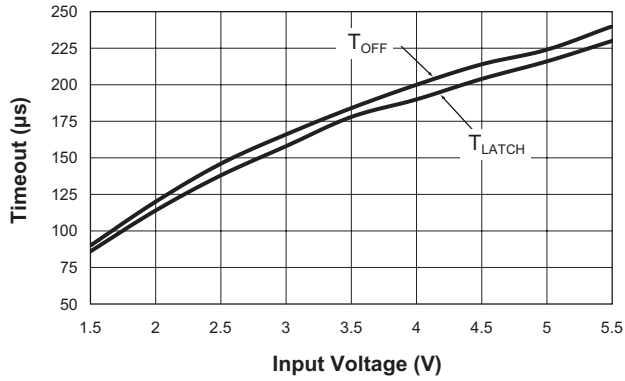
 $R_{\text{DS(ON)}}$ vs. Input Voltage
 $(I_{\text{LOAD}} = 20\text{mA})$

 $R_{\text{DS(ON)}}$ vs. Temperature
 $(V_{\text{IN}} = 3.6\text{V}; I_{\text{LOAD}} = 20\text{mA})$

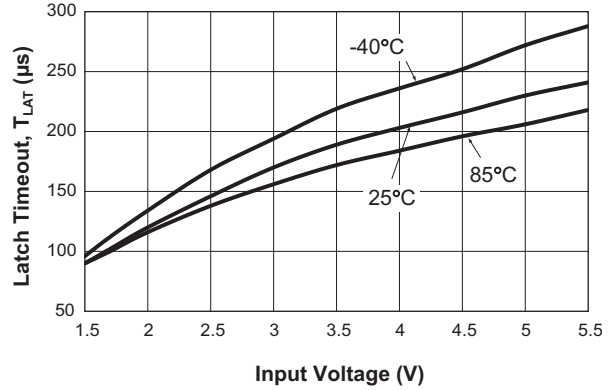
 $R_{\text{DS(ON)}}$ vs. Temperature
 $(V_{\text{IN}} = 5\text{V}; I_{\text{LOAD}} = 20\text{mA})$

Typical Characteristics

EN/SET Timeout vs. Input Voltage



EN/SET Latch Timeout vs. Input Voltage



EN/SET Off Timeout vs. Input Voltage

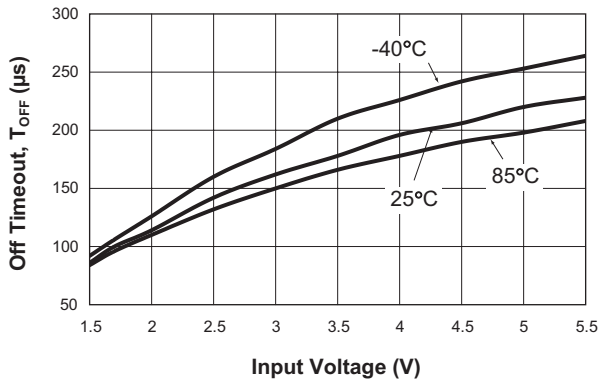

Turn-On Characteristic

($I_{OUT1} = I_{OUT2} = 20mA$)

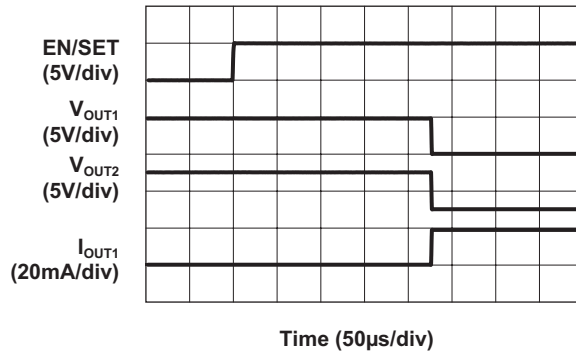

Turn-On Characteristic

($I_{OUT1} = I_{OUT2} = 20mA$)

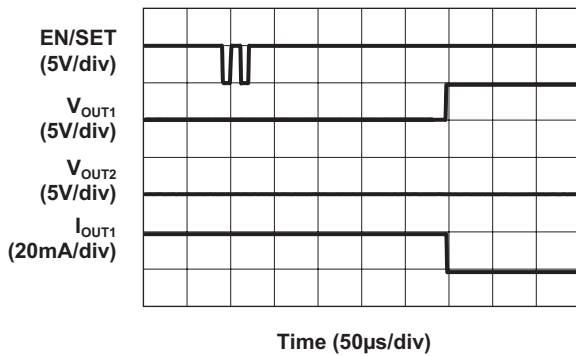

Turn-Off Characteristic

($I_{OUT1} = I_{OUT2} = 20mA$)

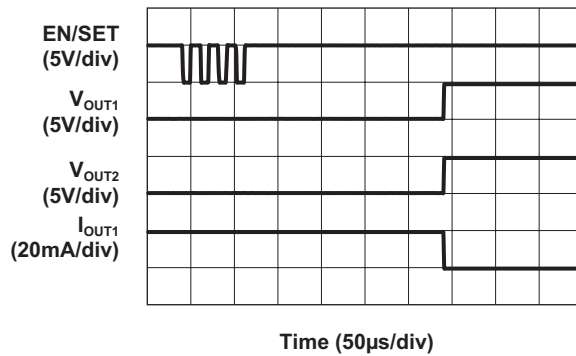

Typical Characteristics

Transition of Outputs
 $(I_{OUT1} = I_{OUT2} = 20\text{mA})$

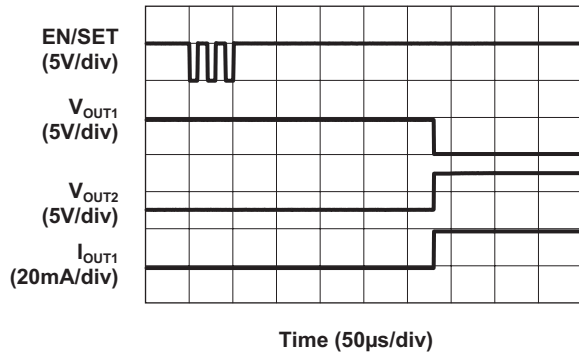

Turn-On Transient Characteristic
 $(I_{OUT1} = I_{OUT2} = 20\text{mA})$

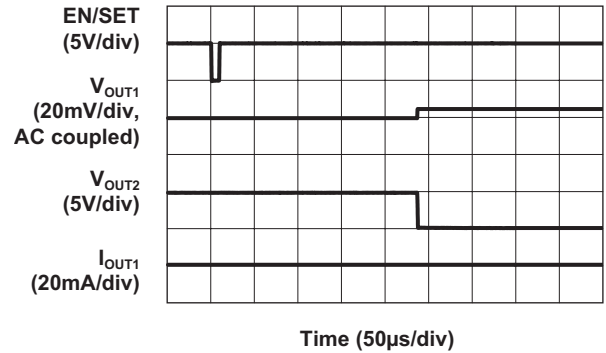

Turn-Off Transient Characteristic
 $(I_{OUT1} = I_{OUT2} = 20\text{mA})$

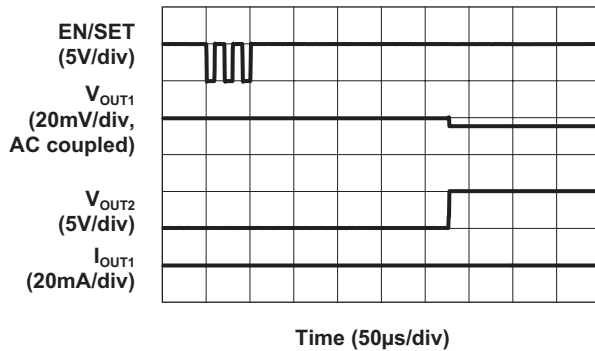

Turn-On Fall Time vs. Temperature

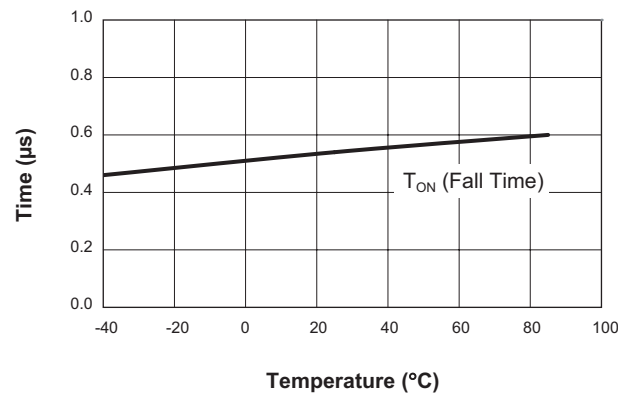

V_{IH} vs. Input Voltage

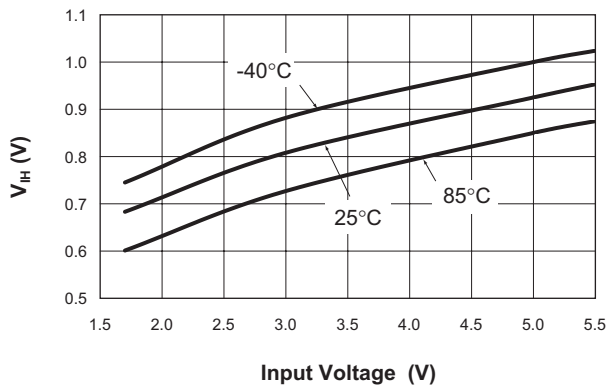

V_{IL} vs. Input Voltage

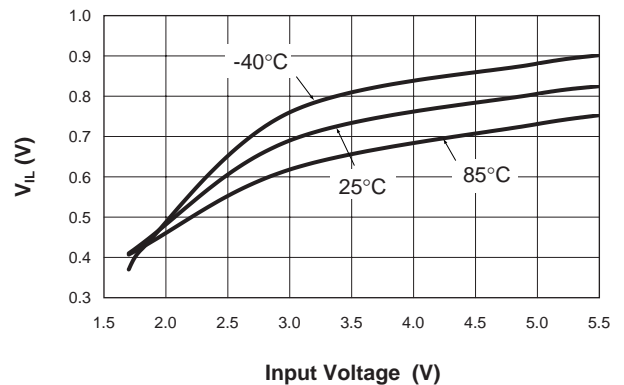

Functional Block Diagram

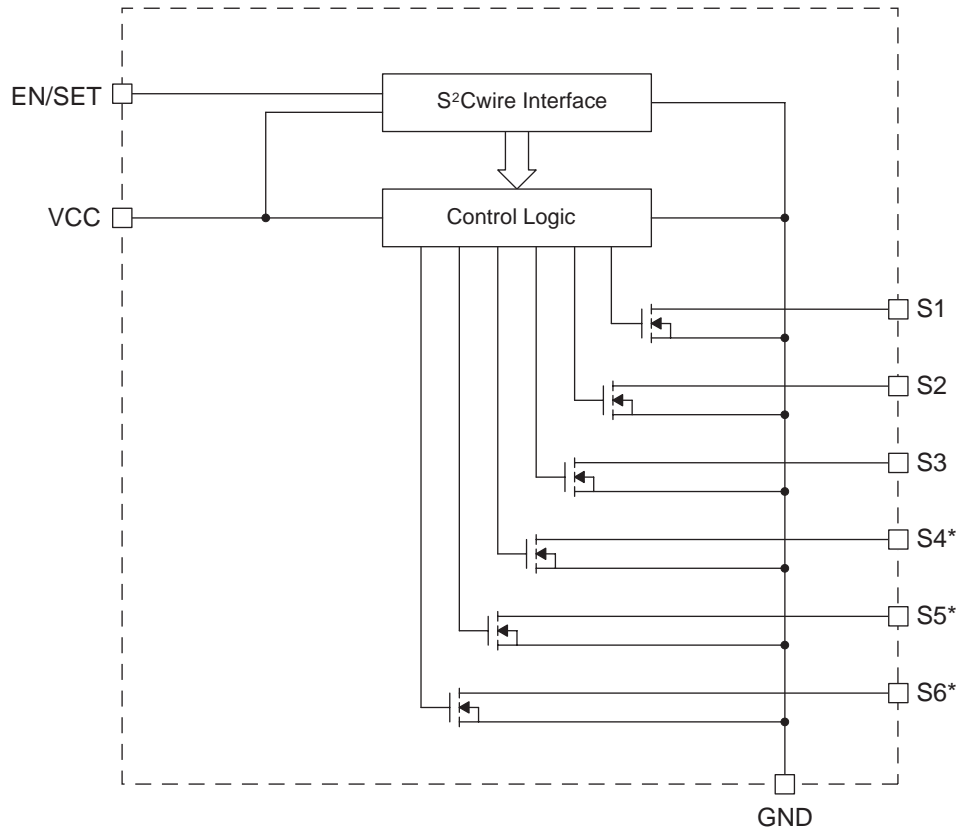

* AAT4297 only

Functional Description

The AAT4295/97 is comprised of three or six low-side N-channel MOSFET load switches primarily targeted for general purpose applications where several load circuits need to be connected to a common ground and controlled from a single microcontroller GPIO output. When a given switch is enabled, the respective switch connects the load input (S1 to S3 for the AAT4295 and S1 to S6 for the AAT4297) to ground through the N-channel MOSFET. Each low-side N-channel MOSFET transistor has a typical on resistance ($R_{DS(ON)}$) of 2Ω when operating from a 3.6V supply. Both the AAT4295

and AAT4297 have been designed to operate with an input voltage range of 1.8V to 5.5V, making them ideal for battery-powered applications.

These devices may be used for load switching applications such as RGB LED fashion lighting, display or keypad backlight LEDs, miscellaneous indicator LED lamps, as well as audio and RF circuits or any other system with a power requirement that does not exceed the thermal dissipation limits of the load switch and device package.

Each switch input may be represented by the following circuit (Figure 1) and simplified equivalent model (Figure 2).

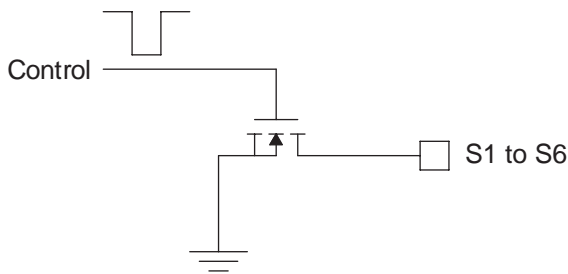

Figure 1: Switch Input Circuit.

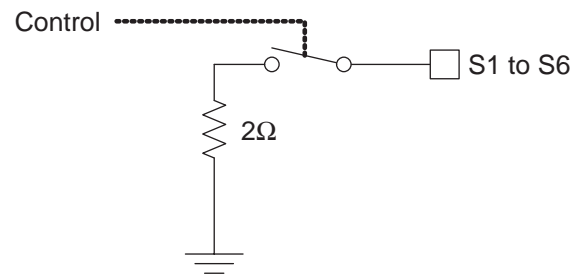

Figure 2: Simplified Equivalent Model.

The state of each switch is controlled via the EN/SET pin using AnalogicTech's S²Cwire interface. To enable a respective switch, a series of clocked pulses should be applied to the EN/SET pin. The number of pulses clocked will determine the switch configuration based on the truth table given in Table 1. At the end of the serial pulse data set, the EN/SET set pin should be held high to latch the clocked data and enable the desired switch configuration. When the device is enabled with the EN/SET held to a logic high state, the quiescent current consumption will typically increase to 3μA at normal ambient room temperatures. If output sequencing of the switches is not necessary, all of the switches may be turned on simultaneously on the first rising edge of the EN/SET pin by simply pulling the EN/SET to a logic high level. The default configuration for one clock pulse is to enable all switches to the "on" state. However, if output sequencing is desired, a series of pulses on the EN/SET pin will set the outputs to the desired state (refer to Table 2 for output settings). For LED lighting applications, the EN/SET line may be clocked at rates up to 1MHz, allowing the user to not only control brightness, but (in the case of color RGB LEDs) color as well.

Output Settings

The ON/OFF state of the MOSFET switches is controlled by the EN/SET serial data input. An internal control counter is clocked on the rising edge of the EN/SET pin, and is decoded into the 8 possible states of the MOSFET for the AAT4295 (see Table 1) and 64 possible states for the AAT4297 (see Table 2). The counter rolls over after 8 clocks and the table repeats.

Clock	OUT3	OUT2	OUT1
1	on	on	on
2	on	on	off
3	on	off	on
4	on	off	off
5	off	on	on
6	off	on	off
7	off	off	on
8	off	off	off

Table 1: AAT4295 EN/SET Settings.

Clock	AAT4297						Clock	AAT4297					
	OUT6	OUT5	OUT4	AAT4295 (only)				OUT6	OUT5	OUT4	OUT3	OUT2	OUT1
				OUT3	OUT2	OUT1							
1	on	on	on	on	on	on	33	off	on	on	on	on	on
2	on	on	on	on	on	off	34	off	on	on	on	on	off
3	on	on	on	on	off	on	35	off	on	on	on	off	on
4	on	on	on	on	off	off	36	off	on	on	on	off	off
5	on	on	on	off	on	on	37	off	on	on	off	on	on
6	on	on	on	off	on	off	38	off	on	on	off	on	off
7	on	on	on	off	off	on	39	off	on	on	off	off	on
8	on	on	on	off	off	off	40	off	on	on	off	off	off
9	on	on	off	on	on	on	41	off	on	off	on	on	on
10	on	on	off	on	on	off	42	off	on	off	on	on	off
11	on	on	off	on	off	on	43	off	on	off	on	off	on
12	on	on	off	on	off	off	44	off	on	off	on	off	off
13	on	on	off	off	on	on	45	off	on	off	off	on	on
14	on	on	off	off	on	off	46	off	on	off	off	on	off
15	on	on	off	off	off	on	47	off	on	off	off	off	on
16	on	on	off	off	off	off	48	off	on	off	off	off	off
17	on	off	on	on	on	on	49	off	off	on	on	on	on
18	on	off	on	on	on	off	50	off	off	on	on	on	off
19	on	off	on	on	off	on	51	off	off	on	on	off	on
20	on	off	on	on	off	off	52	off	off	on	on	off	off
21	on	off	on	off	on	on	53	off	off	on	off	on	on
22	on	off	on	off	on	off	54	off	off	on	off	on	off
23	on	off	on	off	off	on	55	off	off	on	off	off	on
24	on	off	on	off	off	off	56	off	off	on	off	off	off
25	on	off	off	on	on	on	57	off	off	off	on	on	on
26	on	off	off	on	on	off	58	off	off	off	on	on	off
27	on	off	off	on	off	on	59	off	off	off	on	off	on
28	on	off	off	on	off	off	60	off	off	off	on	off	off
29	on	off	off	off	on	on	61	off	off	off	off	on	on
30	on	off	off	off	on	off	62	off	off	off	off	on	off
31	on	off	off	off	off	on	63	off	off	off	off	off	on
32	on	off	off	off	off	off	64	off	off	off	off	off	off

Table 2: Output Settings.

The S²Cwire interface relies on the number of rising edges of the EN/SET pin to load the internal register to a desired count. S²Cwire control latches data after the EN/SET pin has been held high for the preset latch enable time (T_{LAT}). The interface records rising edges of the EN/SET pin and decodes them into one of 8 states for the AAT4295 or to one of 64 states for the AAT4297, as indicated in Tables 1 and 2. The counter can be clocked at speeds up to 1MHz, so different switch combi-

nations may be clocked in lighting applications without any visible perception to the user. Alternatively, the EN/SET clock pulses may be entered one at a time for the desired setting. The first rising edge of EN/SET enables the IC and turns all the switches ON. Once the final clock cycle is received, the EN/SET pin is held high to maintain the device setting. The device is disabled 500 μ s (T_{OFF}) after the EN/SET pin transitions to a logic low state (see Figure 3).

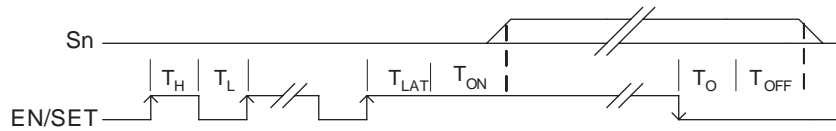

Figure 3: EN/SET Timing Diagram.

Application Information

External Component Selection

The AAT4295 and AAT4297 have been designed so that no external parts are required for the device to function as a general purpose three- or six-position low-side switch. For some applications, the addition of bypass capacitors or pull-up or pull-down resistors may be desired to improve overall system performance.

For lighting applications, such as controlling RGB LEDs, keypad or display backlight LEDs, or photo flash LEDs, no bypass capacitors are necessary. For other general purpose load switching applications which may use some or all of the outputs to switch light load current levels to application circuits, good engineering practice would dictate the use of small bypass capacitors placed on the V_{CC} input and each switch connection that is used to conduct current from the load to ground. The use of small ceramic capacitors between the input and output nodes will aid in reducing line and load transient response effects when the load switch on a given output is turned on or off.

Input Capacitor

Typically, a $0.1\mu\text{F}$ capacitor is recommended for C_{IN} in most applications to provide input line transient response immunity to small changes in the input supply. A C_{IN} capacitor is not required for basic operation. If used, C_{IN} should be located as close to the device V_{IN} pin as practically possible.

There is no specific capacitor equivalent series resistance (ESR) requirement for C_{IN} ; however, for higher current operation, ceramic capacitors are recommended for C_{IN} due to their inherent capability over tantalum or aluminum electrolytic capacitors to withstand input current surges from low impedance sources, such as batteries in portable devices.

Output Capacitor

For typical applications where the AAT4295/97 is used for LED lighting control, no output capacitors are required because the end load is not sensitive to device turn-on or turn-off transient effects.

For improved load transient response in systems using the AAT4295/97 for load switching, the addition of a small output capacitor placed between the output pins and ground can have a beneficial effect. A $0.1\mu\text{F}$ ceramic capacitor is suggested as a reasonable value for an output capacitor.

The output capacitor has no specific capacitor type or ESR requirement. If desired, C_{OUT} may be increased to a value greater than $0.1\mu\text{F}$ without limit to accommodate any load transient condition without adversely affecting the device turn-on slew rate time.

Thermal Considerations

The AAT4295 and AAT4297 are designed to sink a continuous load current to ground when a respective switch is enabled via the S²Cwire control. The limiting characteristic for maximum safe operating load current through a given switch or set of switches is package power dissipation. In order to obtain high operating currents, careful device layout and circuit operating conditions must be taken into account. At any given ambient temperature (T_A), the maximum package power dissipation can be determined by the following equation:

$$P_{D(\text{MAX})} = \frac{T_{J(\text{MAX})} - T_A}{\theta_{JA}}$$

Constants for the AAT4295 are maximum junction temperature, $T_{J(\text{MAX})} = 125^\circ\text{C}$, and package thermal resistance, $\theta_{JA} = 225^\circ\text{C/W}$. Worst case conditions are calculated at the maximum operating tempera-

ture, where $T_A = 85^\circ\text{C}$. Typical conditions are calculated under normal ambient conditions, where $T_A = 25^\circ\text{C}$. At 25°C ambient, the AAT4295 is capable of dissipating 444.4mW of power and the AAT4297 is capable of dissipating 625mW of power. At 85°C ambient, the AAT4295 is capable of dissipating 177.8mW of power and the AAT4297 can dissipate 250mW.

The power dissipation of any given MOSFET switch is limited by its respective on resistance (R_{DS}). The R_{DS} of any given MOSFET switch is controlled by the applied gate voltage to the switch, which is set by the applied V_{CC} supply and the ambient operating temperature. Switch RDS for the AAT4295 or AAT4297 may be estimated by using the R_{DS} versus Temperature curve in the Typical Characteristics section of this datasheet. The maximum current of any given switch can be calculated for a given operating temperature and V_{CC} supply level. The corresponding R_{DS} is determined by use of the R_{DS} vs. Temperature curve for the given V_{CC} .

Given the maximum package power dissipation and operating temperature, the maximum current through any switch or combination of switches can be calculated using the following formula:

$$I_{\text{SWITCH(MAX)}} = \left(\frac{P_{D(\text{MAX})}}{R_{DS}} \right)^{\frac{1}{2}}$$

Example: If all the switches on an AAT4295 were closed simultaneously, each switch could handle up to 271mA of current at 25°C for total of 813mA. For the same set of operating conditions at 25°C , the AAT4297 can handle up to 208mA per switch for a total of 1.25A for all six switches. If the load current for a desired application exceeds the recommended current at a given temperature, two or more switches may be operated in parallel as long as the overall power dissipation of the device package is not exceeded. If different current levels are passed through different switches on a given device, then one should total up the power dissipation for each switch and assure the sum of the power dissipation does not exceed the power rating for the package.

Application Circuits

Today, many mobile phones and similar products contain RGB LED fashion lighting, LCD display and sub-display, as well as keypad backlighting and photo flash LEDs. Due to the nature of common anode RGB LEDs, the AAT4295 and AAT4297 make ideal low-cost lighting control solutions. In general, most types of LEDs can be controlled via a low-side MOSFET switch and current limiting ballast resistor. The following application circuits (Figures 4 through 7) show voltage boosting charge pumps to power RGB and flash LEDs. However, if a voltage or current source is already available in a given product design, the charge pump circuit block may be replaced with the existing power source solution. Since both the AAT4295 and AAT4297 require only one GPIO line from the system microcontroller to enable and disable all the switches via the EN/SET input, these solutions can provide a simple way to add lighting solutions to existing design platforms.

Driving LED Loads

When driving LEDs with a voltage source, series ballast resistors must be used to limit the LED forward current. The LED current will vary with supply voltage and LED forward voltage. Most types of LEDs have forward voltage specifications ranging from 2.0V to 5.0V. When controlling an LED of any type with a low-side MOSFET switch, the necessary series ballast resistor value can be calculated from the following formula:

$$R_{\text{BALLAST}} = \frac{(V_{\text{IN}} - V_{\text{F}})}{I_{\text{LED}}} - R_{\text{DS(ON)}}$$

Where:

R_{BALLAST} is the value of resistor to be placed in series with the LED (Ω).

V_{IN} is the input supply voltage to the device (V).

V_{F} is the forward voltage of the LED (V).

$R_{\text{DS(ON)}}$ is the resistance of the switch when it is turned on (Ω).

I_{LED} is the desired operating current of the LED (A).

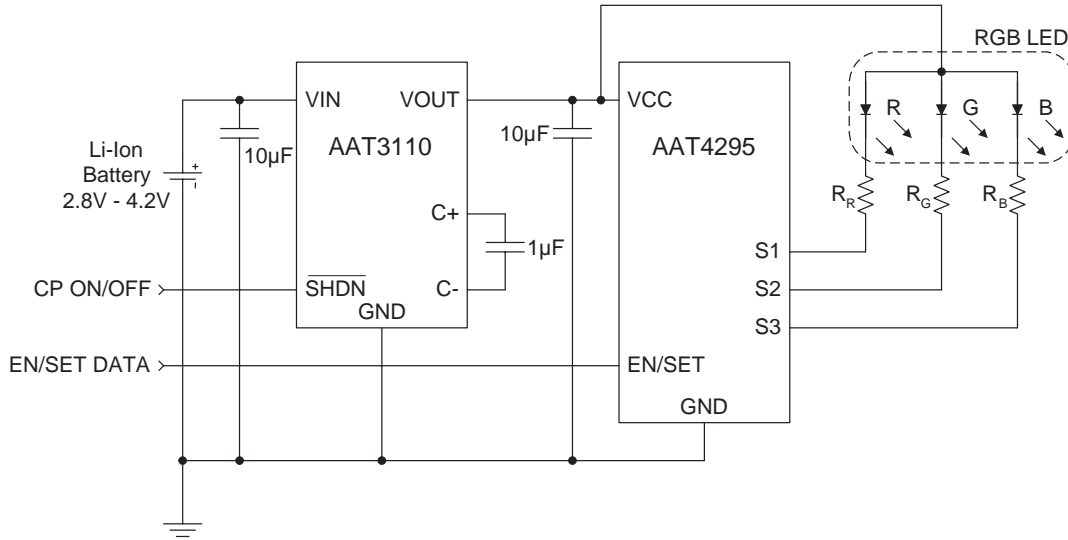

Figure 4: Single RGB LED Fashion Light Solution Using an AAT4295.

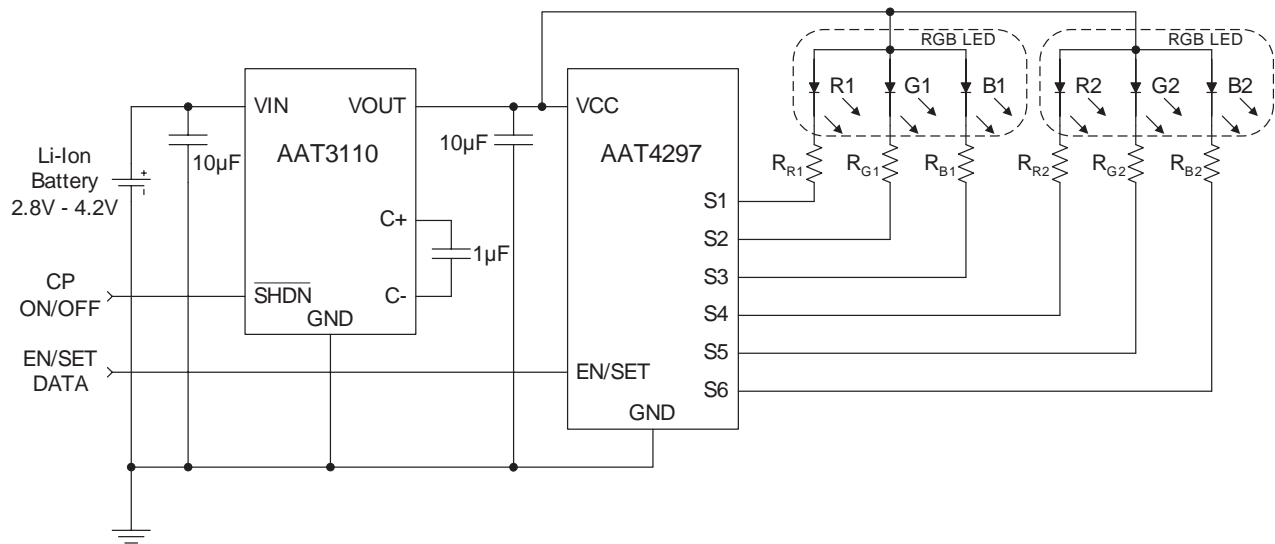

Figure 5: Dual RGB LED Fashion Light Solution Using an AAT4297.

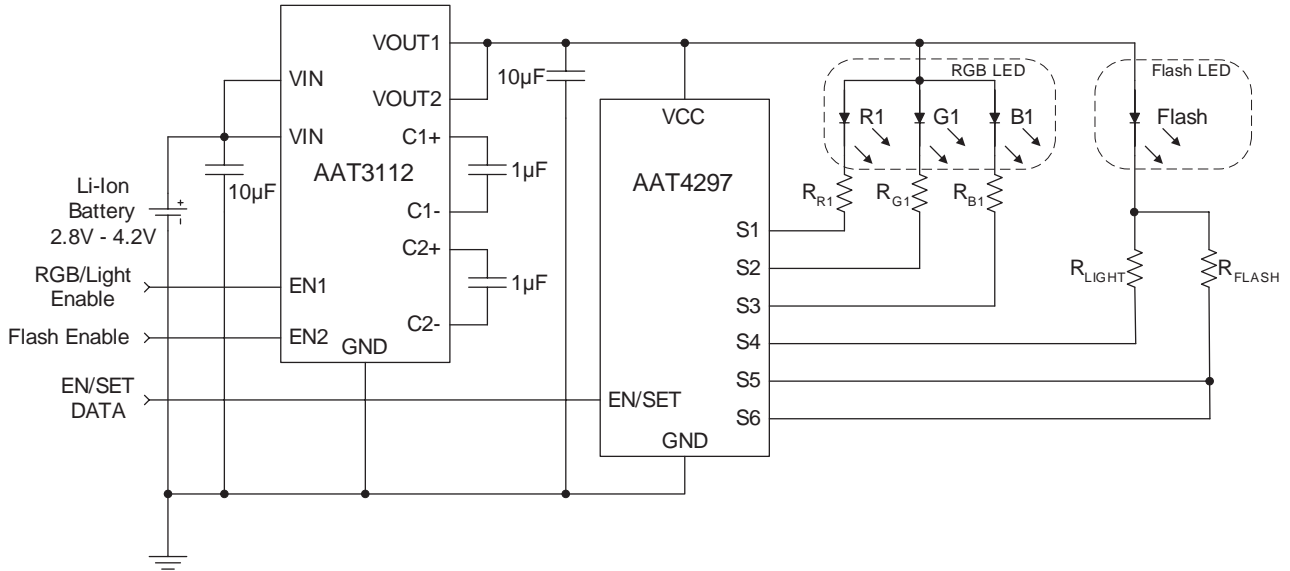

Figure 6: RGB LED Fashion Light With a Dual Mode Light/Strobe Flash LED Solution Using an AAT4297.

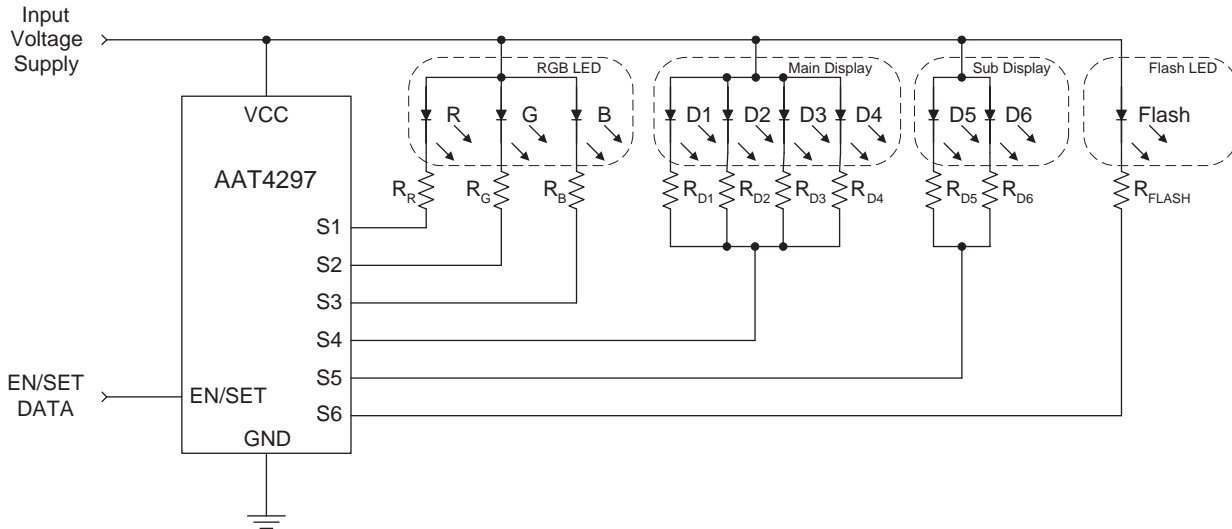

Figure 7: Total Lighting Control Solution Using an AAT4297. Includes RGB Fashion Light, Main Display and Sub-Display LCD Backlight, and Photo Flash LED.

Ordering Information

Package	Marking ¹	Part Number (Tape and Reel) ²
SC70JW-8	RBXYY	AAT4295IJS-T1
TSOPJW-12	RCXYY	AAT4297ITP-T1



All AnalogicTech products are offered in Pb-free packaging. The term “Pb-free” means semiconductor products that are in compliance with current RoHS standards, including the requirement that lead not exceed 0.1% by weight in homogeneous materials. For more information, please visit our website at <http://www.analogictech.com/pbfree>.

Package Information

SC70JW-8

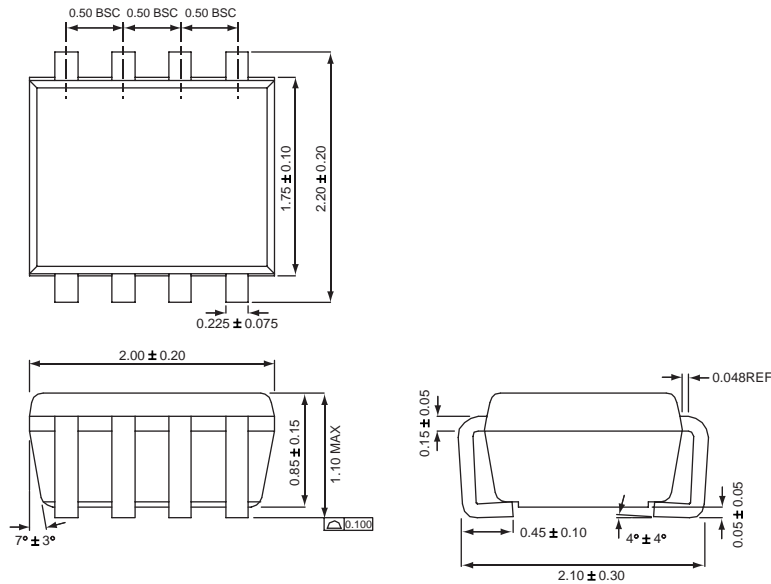

All dimensions in millimeters.

1. XYY = assembly and date code.
 2. Sample stock is generally held on part numbers listed in **BOLD**.

TSOPJW-12

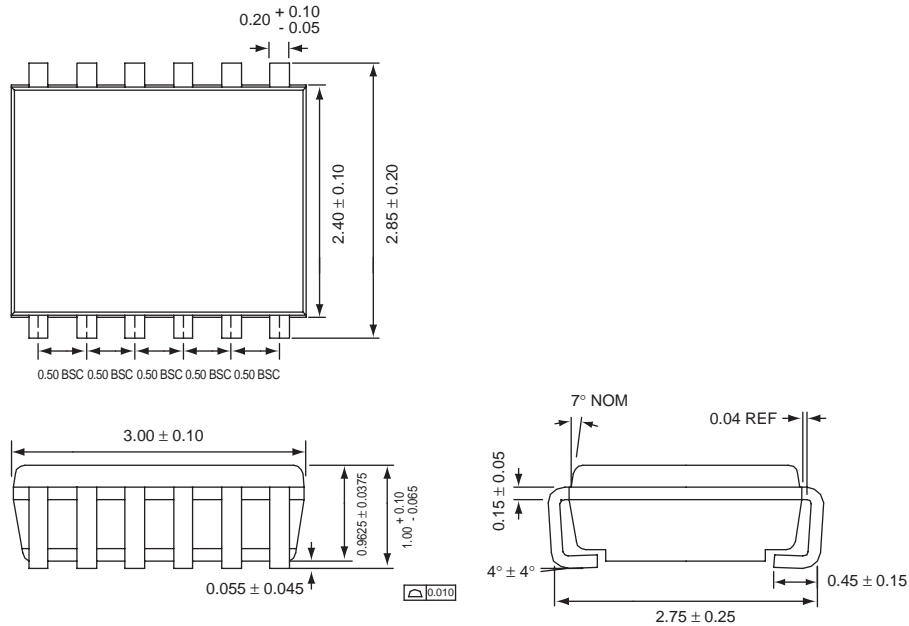

All dimensions in millimeters.

© Advanced Analogic Technologies, Inc.

AnalogicTech cannot assume responsibility for use of any circuitry other than circuitry entirely embodied in an AnalogicTech product. No circuit patent licenses, copyrights, mask work rights, or other intellectual property rights are implied. AnalogicTech reserves the right to make changes to their products or specifications or to discontinue any product or service without notice. Customers are advised to obtain the latest version of relevant information to verify, before placing orders, that information being relied on is current and complete. All products are sold subject to the terms and conditions of sale supplied at the time of order acknowledgement, including those pertaining to warranty, patent infringement, and limitation of liability. AnalogicTech warrants performance of its semiconductor products to the specifications applicable at the time of sale in accordance with AnalogicTech's standard warranty. Testing and other quality control techniques are utilized to the extent AnalogicTech deems necessary to support this warranty. Specific testing of all parameters of each device is not necessarily performed.

Advanced Analogic Technologies, Inc.
 830 E. Arques Avenue, Sunnyvale, CA 94085
 Phone (408) 737-4600
 Fax (408) 737-4611