

PART NO	"A" DIMENSION	CENTER CONTACT PLATING: TFS-1B
UCBJ224	.193±.015	5G; .000050 GOLD
UCBJ224-1	.156±.015	3G; .000030 GOLD

DATA CONTAINED IN THIS DOCUMENT IS PROPRIETARY TO TROMPETER ELECTRONICS INC. AND SHALL NOT BE DISCLOSED, COPIED OR USED FOR PROCUREMENT OR MANUFACTURE WITHOUT EXPRESS WRITTEN PERMISSION.

**REVISIONS**

REV	DESCRIPTIONS	DATE	APPROVED
L	REVISED PER ECO # 16861	4/16/09	<i>[Signature]</i>

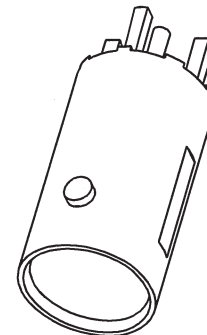
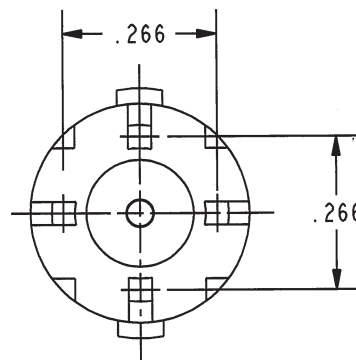
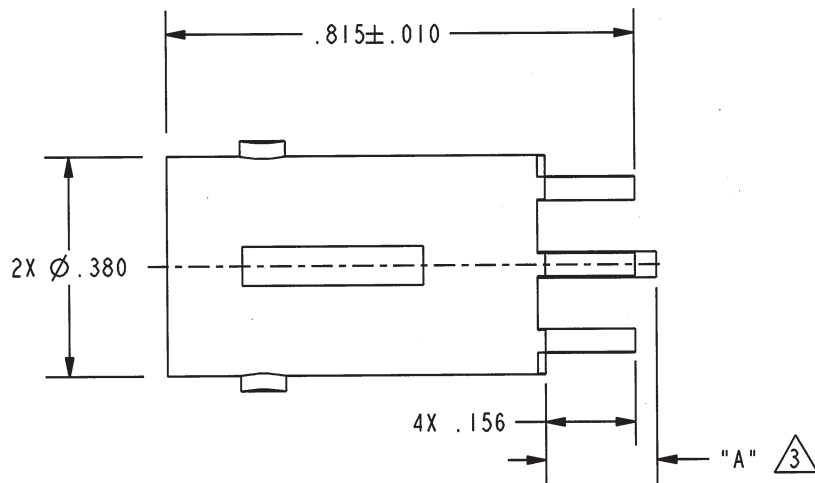

SCALE 2/1

SCALE 3/1

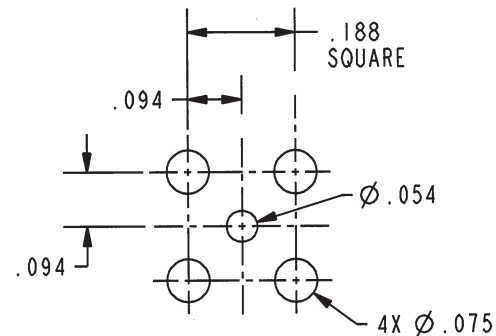

RECOMMENDED MTG HOLE PATTERN SCALE 3/1

**RED INDICATES ORIGINAL**

4. PRE-TIN LEGS .0015 MAXIMUM THICK WITH SN63 OR EQUIVALENT SOLDER PER QQ-S-571 TO WITHIN .060 MAXIMUM OF SHOULDER

△ CENTER CONTACT ONLY

2. FINISH: TFS-1Y (NICKEL)

1. 75 Ω CIRCUIT BOARD MOUNT, ZINC DIECAST, BNC RECEPTACLE

NOTES: UNLESS OTHERWISE SPECIFIED.

INTERPRET DRAWING PER MIL-STD-100. DIMENSIONS ARE IN INCHES AND INCLUDE FINISH THICKNESS UNLESS OTHERWISE SPECIFIED.		TOL: UNLESS SPECIFIED. .XX ± .02 .XXX ± .010 ANGLE ± 1°			
DRW J. CARPENTER	2-26-09	MATERIAL:	TITLE:  UCBJ224		
CHK M.J.	4-1-09	QUALITY	FINISH:	SIZE <b>A</b>	CAGE CODE <b>14949</b>
MANUF				DRAWING NO. 1-0532	REV. L
APPROVED <i>[Signature]</i>	4/1/09	PROT FILE NO. 1-0532	DO NOT SCALE DWG	SCALE 3/1	DATE 3-21-95
NEXT ASSY					SHEET IC