

Features

- Operating voltage: 1.5V
- Auto walking or jogging detection
- Step number/mileage/kilometer/calorie display
- LCD display
- An oscillator with 32kHz
- Few external components
- Low power consumption
- An LCD with 1/3 duty, 1/2 bias

General Description

The HT1350 is a step counter IC implemented in the CMOS technology. It provides an LCD with a whole course (kilometer/mile) as well as the consumed calorie display.

The HT1350 consists of internal oscillator circuit, a step number/kilometer/mile/calorie step

counter, a voltage doubler, and an LCD display multiplexer.

The IC can automatically distinguish walking from jogging, thus making appropriate calculations.

Block Diagram

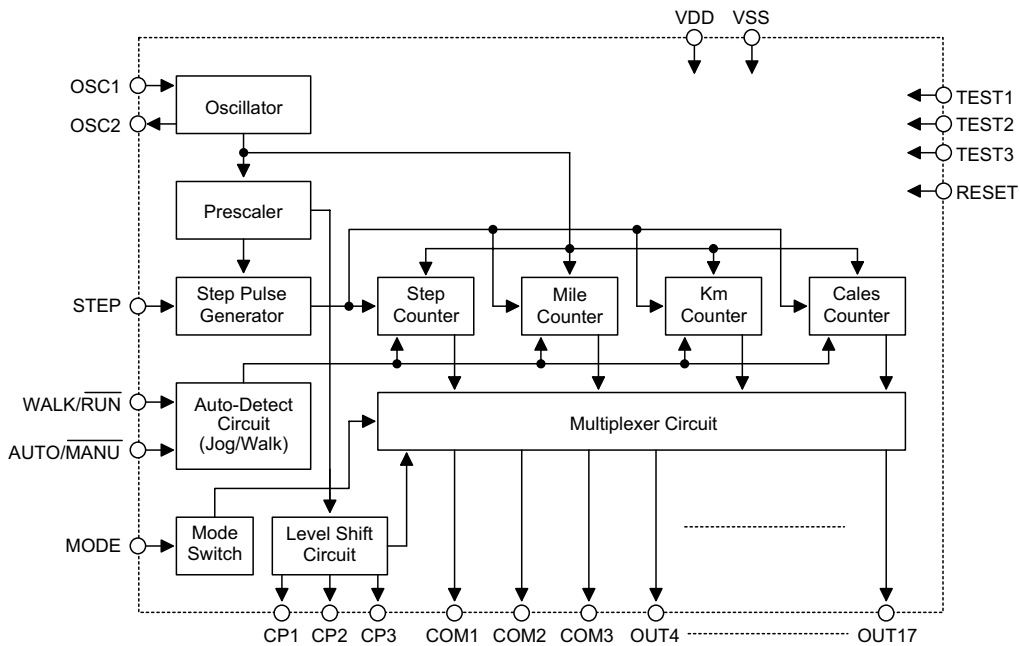

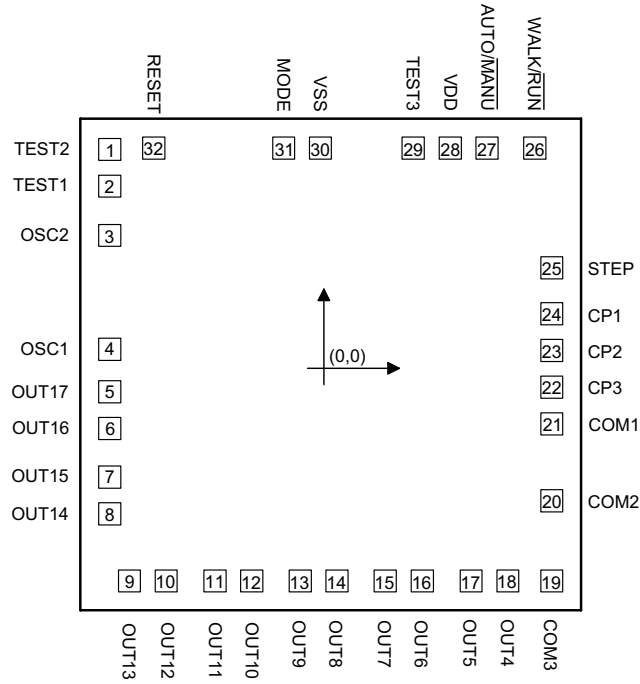
Pad Assignment

Chip size: $2725 \times 2780 (\mu\text{m})^2$

* The IC substrate should be connected to VDD in the PCB layout artwork.

Unit: μm

Pad No.	X	Y	Pad No.	X	Y
1	-1206.00	1159.50	17	762.00	-1190.50
2	-1206.00	994.50	18	962.00	-1190.50
3	-1206.00	661.70	19	1202.00	-1190.50
4	-1206.00	71.50	20	1202.00	-753.50
5	-1206.00	-159.50	21	1202.00	-335.50
6	-1206.00	-359.50	22	1202.00	-135.50
7	-1206.00	-624.50	23	1202.00	65.50
8	-1206.00	-824.50	24	1202.00	259.50
9	-1098.00	-1190.50	25	1202.00	537.00
10	-898.00	-1190.50	26	1078.00	1167.50
11	-633.00	-1190.50	27	812.00	1167.50
12	-433.00	-1190.50	28	631.00	1167.50
13	-168.00	-1190.50	29	447.00	1167.50
14	32.00	-1190.50	30	-59.00	1167.50
15	297.00	-1190.50	31	-259.00	1167.50
16	497.00	-1190.50	32	-966.00	1167.50

Pad Description

Pad No	Pad Name	I/O	Internal Connection	Descriptions
1	TEST2	I/O	—	For IC test only
2	TEST1	I/O	—	For IC test only
3	OSC2	O	—	Oscillator output
4	OSC1	I	—	Oscillator input
5~18	OUT17~OUT4	O	CMOS	Display data output pads for segments
19~21	COM3~COM1	O	NMOS	Display data output pads for commons
22	CP3	O	*	Bias supply voltage pad for driving the LCD panel
23~24	CP2~CP1	O	*	LCD bias supply voltage control pads
25	STEP	I	CMOS Pull-high	Step sensor input pad
26	WALK/RUN	I	CMOS Pull-high	Walk/Run mode manual set pad
27	AUTO/MANU	I	CMOS Pull-high	Auto detection/Manual set selection pad
28	VDD	I	—	Positive power supply
29	TEST3	I/O	—	For IC test only
30	VSS	I	—	Negative power supply (GND)
31	MODE	O	CMOS Pull-high	LCD display mode selection
32	RESET	O	CMOS Pull-high	System reset pad

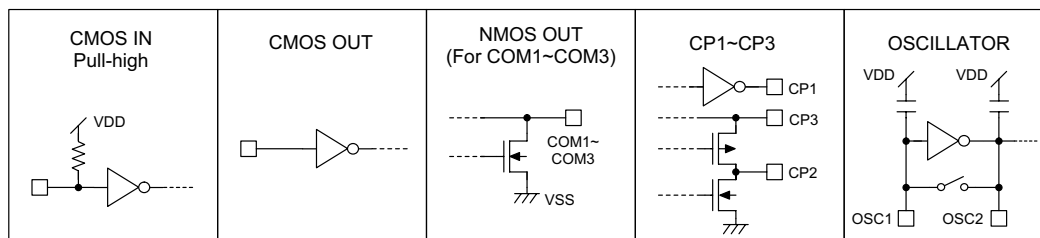
Approximate internal connection circuits

Absolute Maximum Ratings

Supply Voltage	-0.3V to 5V	Storage Temperature.....	-50°C to 125°C
Input Voltage	$V_{SS}-0.3V$ to $V_{DD}+0.3V$	Operating Temperature	0°C to 70°C

Note: These are stress ratings only. Stresses exceeding the range specified under "Absolute Maximum Ratings" may cause substantial damage to the device. Functional operation of this device at other conditions beyond those listed in the specification is not implied and prolonged exposure to extreme conditions may affect device reliability.

Electrical Characteristics

 $T_a=25^{\circ}C$

Symbol	Parameter	Test Conditions		Min.	Typ.	Max.	Unit
		V_{DD}	Conditions				
V_{DD}	Operating Voltage	—	—	1.3	1.5	1.7	V
I_{DD}	Operating Current	1.5V	No load, $f_{OSC}=32kHz$	—	1.5	3	μA
I_{STB}	Standby Current	1.5V	—	—	0.5	1	μA
V_{IL}	Input Low Voltage	1.5V	—	—	—	$0.2V_{DD}$	V
V_{IH}	Input High Voltage	1.5V	—	$0.8V_{DD}$	—	—	V
f_{OSC}	System Frequency	1.5V	—	—	32	—	kHz

Functional Description

The HT1350 is a step counter IC. It is used to automatically count the step number taken by a runner and to display the whole course (kilometer/mile) combined with the calories consumed on the LCD.

The IC is turned on and off with respect to the on/off status of a short of spring switch which corresponds to the up/down motion of the steps. The output of step number can be changed to kilometers/miles or calories by counting the total number of times the step switch is closed.

The IC can automatically distinguish between walking and jogging and make the according calculations. The output of the LCD is busy when the RESET key is pressed. Once the LCD is in the busy state, the step counter will start counting at 0 after 0.5 seconds till the runner stops running and stands still. After the step counter stops counting, pressing the MODE key will display the step number→mile→kilometer→calorie in sequence.

LCD Display

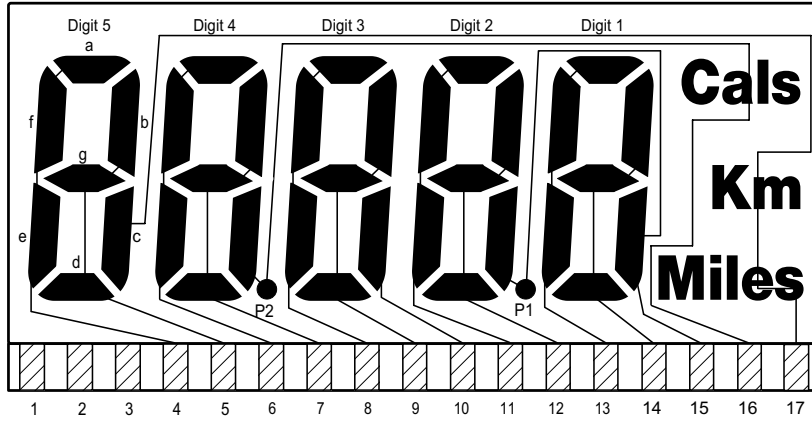

1	2	3	4	5	6	7	8	9	10	11	12	13	14	15	16	17
Com1			D5e	D5d	D4e	D4d	D3e	D3d		D2e	D2d	D1e	D1d	P1	P2	Miles
	Com2		D5f	D5g	D4f	D4g	D3f	D3g	D3c	D2f	D2g	D1f	D1g	D2c	D4c	D5c
		Com3	D5a	D5b	D4a	D4b	D3a	D3b		D2a	D2b	D1a	D1b	D1c	Cals	Km

Application Circuit

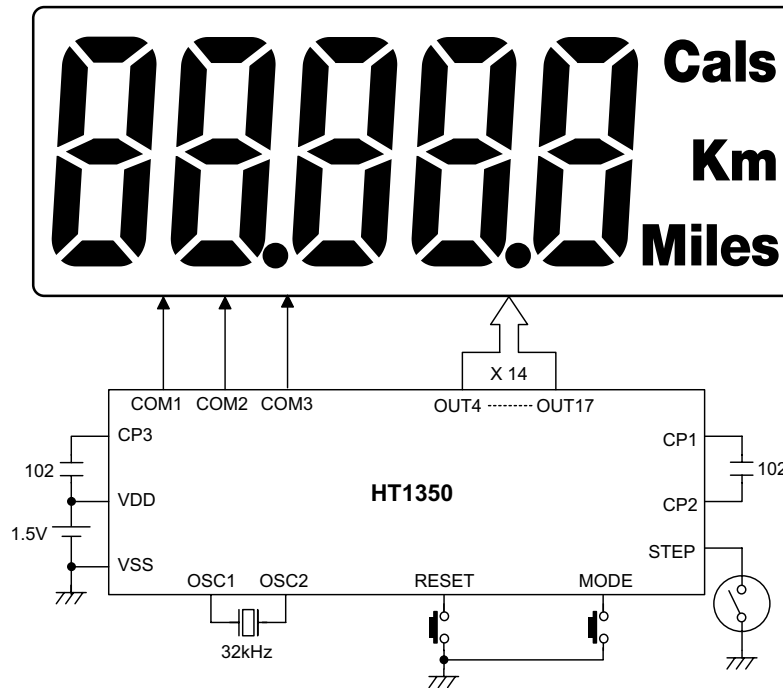

Holtek Semiconductor Inc. (Headquarters)

No.3 Creation Rd. II, Science-based Industrial Park, Hsinchu, Taiwan, R.O.C.
Tel: 886-3-563-1999
Fax: 886-3-563-1189

Holtek Semiconductor Inc. (Taipei Office)

5F, No.576, Sec.7 Chung Hsiao E. Rd., Taipei, Taiwan, R.O.C.
Tel: 886-2-2782-9635
Fax: 886-2-2782-9636
Fax: 886-2-2782-7128 (International sales hotline)

Holtek Microelectronics Enterprises Ltd.

RM.711, Tower 2, Cheung Sha Wan Plaza, 833 Cheung Sha Wan Rd., Kowloon, Hong Kong
Tel: 852-2-745-8288
Fax: 852-2-742-8657

Copyright 1999 by HOLTEK SEMICONDUCTOR INC.

The information appearing in this Data Sheet is believed to be accurate at the time of publication. However, Holtek assumes no responsibility arising from the use of the specifications described. The applications mentioned herein are used solely for the purpose of illustration and Holtek makes no warranty or representation that such applications will be suitable without further modification, nor recommends the use of its products for application that may present a risk to human life due to malfunction or otherwise. Holtek reserves the right to alter its products without prior notification. For the most up-to-date information, please visit our web site at <http://www.holtek.com.tw>.