



# Chip Inductors – 0603CT Series (1608)

- Very low profile – only 60% of the height of our other 0603 inductor series
- Excellent Q, low DCR and very high SRF

**Designer's Kit C423** contains 10 each of all 5% values and **Designer's Kit C423-2** contains 10 each of all 2% values.

Part number <sup>1</sup>	Inductance <sup>2</sup> (nH)	Percent tolerance <sup>3</sup>	900 MHz		1.7 GHz		SRF typ <sup>5</sup> (GHz)	DCR max <sup>6</sup> (Ohms)	Irms <sup>7</sup> (mA)
			L typ	Q typ <sup>4</sup>	L typ	Q typ <sup>4</sup>			
0603CT-1N0XJL_	1.0	<b>5</b>	0.98	39	0.99	58	16.0	0.045	1600
0603CT-1N2XJL_	1.2	<b>5</b>	1.18	35	1.19	50	16.0	0.105	1100
0603CT-2N0XJL_	2.0	<b>5</b>	1.98	46	1.98	70	12.0	0.034	1900
0603CT-2N3XJL_	2.3	<b>5</b>	2.27	55	2.28	81	11.0	0.046	1600
0603CT-2N5XJL_	2.5	<b>5</b>	2.48	52	2.50	77	11.0	0.060	1300
0603CT-3N0X_L_	3.0	<b>5,2</b>	2.96	57	2.97	82	10.7	0.039	1600
0603CT-3N3X_L_	3.3	<b>5,2</b>	3.27	60	3.33	83	7.00	0.039	1600
0603CT-3N6X_L_	3.6	<b>5,2</b>	3.58	69	3.63	95	7.00	0.044	1600
0603CT-3N9X_L_	3.9	<b>5,2</b>	3.87	68	3.95	90	6.30	0.050	1400
0603CT-4N3X_L_	4.3	<b>5,2</b>	4.26	58	4.34	84	6.30	0.076	1300
0603CT-4N7X_L_	4.7	<b>5,2</b>	4.66	50	4.75	70	5.60	0.120	960
0603CT-5N1X_L_	5.1	<b>5,2</b>	5.12	68	5.18	93	5.50	0.050	1400
0603CT-5N6X_L_	5.6	<b>5,2</b>	5.60	67	5.73	90	5.05	0.058	1300
0603CT-6N8X_L_	6.8	<b>5,2</b>	6.78	60	7.00	81	4.50	0.080	1200
0603CT-7N2X_L_	7.2	<b>5,2</b>	7.19	65	7.44	88	4.50	0.047	1500
0603CT-8N2X_L_	8.2	<b>5,2</b>	8.18	60	8.46	78	4.25	0.075	1300
0603CT-9N5X_L_	9.5	<b>5,2</b>	9.52	63	9.92	80	3.95	0.092	1100
0603CT-10NX_L_	10	<b>5,2</b>	10.0	67	10.4	85	3.95	0.075	1300
0603CT-11NX_L_	11	<b>5,2</b>	11.0	66	11.5	86	4.00	0.110	1000
0603CT-12NX_L_	12	<b>5,2</b>	12.0	68	12.7	85	3.50	0.130	920
0603CT-15NX_L_	15	<b>5,2</b>	15.2	65	16.1	80	3.30	0.145	800
0603CT-16NX_L_	16	<b>5,2</b>	16.3	63	17.5	76	3.10	0.175	760
0603CT-18NX_L_	18	<b>5,2</b>	18.1	66	19.2	80	2.95	0.200	720
0603CT-20NX_L_	20	<b>5,2</b>	20.2	67	21.6	80	2.90	0.175	760
0603CT-22NX_L_	22	<b>5,2</b>	22.4	60	24.3	70	2.75	0.220	700
0603CT-24NX_L_	24	<b>5,2</b>	24.4	61	26.5	72	2.70	0.240	680
0603CT-27NX_L_	27	<b>5,2</b>	27.4	62	29.8	75	2.55	0.270	670
0603CT-30NX_L_	30	<b>5,2</b>	30.5	62	33.9	73	2.45	0.330	600
0603CT-33NX_L_	33	<b>5,2</b>	34.0	55	39.1	61	2.20	0.330	600
0603CT-36NX_L_	36	<b>5,2</b>	37.2	61	42.3	63	2.30	0.335	600
0603CT-39NX_L_	39	<b>5,2</b>	40.3	60	45.3	65	2.25	0.400	570
0603CT-43NX_L_	43	<b>5,2</b>	44.5	57	51.3	60	2.10	0.440	530
0603CT-47NX_L_	47	<b>5,2</b>	48.2	55	57.8	57	1.90	0.540	470
0603CT-51NX_L_	51	<b>5,2</b>	53.0	55	63.2	55	1.85	0.570	440
0603CT-56NX_L_	56	<b>5,2</b>	59.4	54	75.4	48	1.75	0.700	420

1. When ordering, specify **tolerance**, **termination** and **packaging** codes:

0603CT-56NX **G** **L** **W**

**Tolerance:** **G** = 2% **J** = 5% (Table shows stock tolerances in bold.)

**Termination:** **L** = RoHS compliant silver-palladium-platinum-glass frit.  
Special order: **T** = RoHS tin-silver-copper (95.5/4/0.5)  
or **S** = non-RoHS tin-lead (63/37).

**Packaging:** **W** = 7" machine-ready reel. EIA-481 punched paper tape (2000 parts per full reel).

**U** = Less than full reel. In tape, but not machine ready.  
To have a leader and trailer added (\$25 charge),  
use code letter **W** instead.

2. Inductance measured at 250 MHz, 0.1 Vrms, 0 Adc using Coilcraft SMD-A fixture in Agilent/HP 4287A impedance analyzer.

3. Tolerances in bold are stocked for immediate shipment.

4. Q measured using Agilent/HP4291A with Agilent/HP 16193 test fixture.

5. SRF measured using Agilent/HP 8722ES network analyzer and Coilcraft SMD-D test fixture.

6. DCR measured on Cambridge Technology micro-ohmmeter and Coilcraft CCF858 test fixture.

7. Current that causes a 15°C temperature rise from 25°C ambient.

8. Electrical specifications at 25°C.

Refer to Doc 362 "Soldering Surface Mount Components" before soldering.

**Coilcraft**<sup>®</sup>

Specifications subject to change without notice.  
Please check our website for latest information.

Document 485-1 Revised 10/03/08

1102 Silver Lake Road Cary, Illinois 60013 Phone 847/639-6400 Fax 847/639-1469

E-mail [info@coilcraft.com](mailto:info@coilcraft.com) Web <http://www.coilcraft.com>



# 0603CT Series (1608)

## Typical L vs Frequency

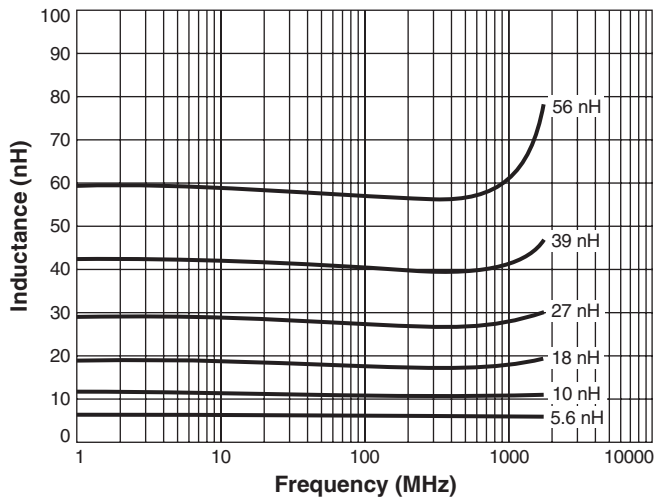

## Typical Q vs Frequency

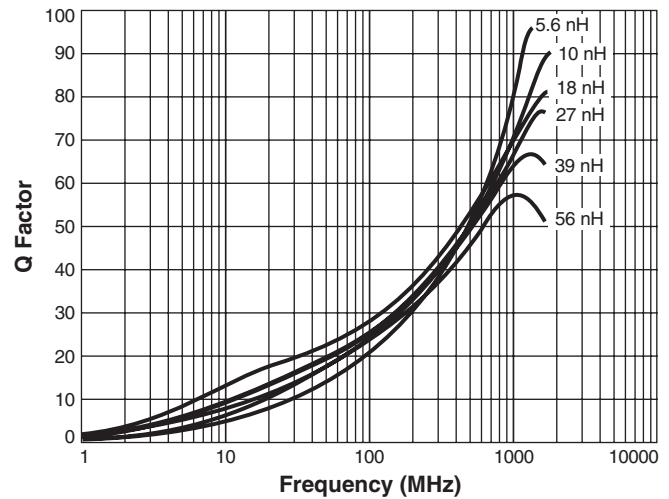

## Typical Irms Derating

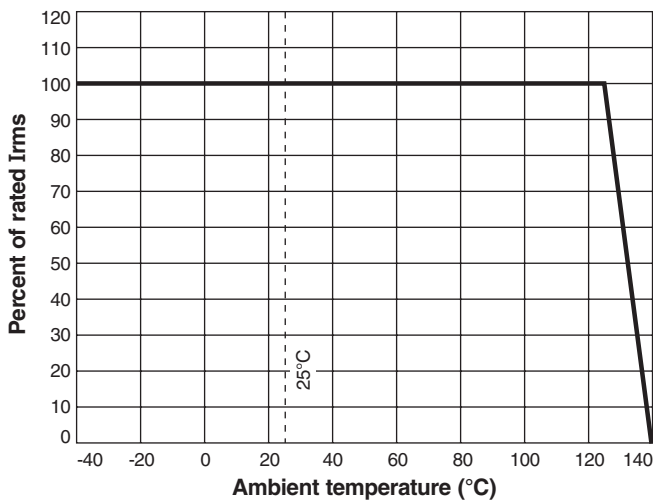

**Designer's Kit C423** contains 10 each of all 5% values;  
**Designer's Kit C423-2** contains 10 each of all 2% values

**Core material** Ceramic

**Terminations** RoHS compliant silver-palladium-platinum-glass frit. Other terminations available at additional cost.

**Weight** 160 – 190 mg

**Ambient temperature** -40°C to +125°C with Irms current, +125°C to +140°C with derated current

**Storage temperature** Component: -40°C to +125°C. Packaging: -40°C to +80°C

**Resistance to soldering heat** Max three 40 second reflows at +260°C, parts cooled to room temperature between cycles

**Temperature Coefficient of Inductance (TCL)** +25 to +125 ppm/°C

**Moisture Sensitivity Level (MSL)** 1 (unlimited floor life at <30°C / 85% relative humidity)

**Failures in Time (FIT) / Mean Time Between Failures (MTBF)** One per billion hours / one billion hours, calculated per Telcordia SR-332

**Packaging** 2000/7" reel; Paper tape: 8 mm wide, 0.68 mm thick, 4 mm pocket spacing

**PCB washing** Only pure water or alcohol recommended

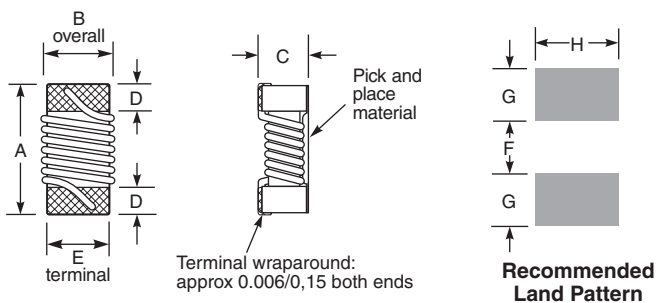

A max	B max	C max	D	E	F	G	H
0.064	0.033	0.024	0.013	0.030	0.025	0.025	0.040 inches
1,63	0,84	0,61	0,33	0,76	0,64	0,64	1,02 mm



Specifications subject to change without notice.  
 Please check our website for latest information.

Document 485-2 Revised 10/03/08

1102 Silver Lake Road Cary, Illinois 60013 Phone 847/639-6400 Fax 847/639-1469

E-mail [info@coilcraft.com](mailto:info@coilcraft.com) Web <http://www.coilcraft.com>