



XTX™ **conga-XEVAL**

*Detailed description of the congatec XTX™ evaluation
baseboard*

User's Guide

Revision 1.3

Revision History

Revision	Date	Author	Changes
1.0	17.10.05	HCH	Official release
1.1	09.11.05	HCH	Changed LPT/#FPY Signal; updated debug display description; added TP.
1.2	20.01.06	GDA	Corrected errors in sections 2.2, 2.4, 3.2.2 and added section 5 "Mechanical Drawing conga-XEVAL". Added link table to connector diagram page. Added description of pins 7 and 8 in the LCD power connector pinout table in section 3.4.2. Changed the LCD Voltage value for Jumper X45 5-6 from 12V to 3.3V.
1.3	20.06.06	GDA	Added pinout table for LPT2, COM3 and COM4. Corrected fuse values for X47 pinout, was 15A but the correct value is 1.5A. Added connection possibilities diagram for X47 connector.

Preface

This user's guide provides information about the components, features and connectors available on the XTX Evaluation Baseboard.

Disclaimer

The information contained within this user's guide, including but not limited to any product specification, is subject to change without notice.

congatec AG provides no warranty with regard to this user's guide or any other information contained herein and hereby expressly disclaims any implied warranties of merchantability or fitness for any particular purpose with regard to any of the foregoing. congatec AG assumes no liability for any damages incurred directly or indirectly from any technical or typographical errors or omissions contained herein or for discrepancies between the product and the user's guide. In no event shall congatec AG be liable for any incidental, consequential, special, or exemplary damages, whether based on tort, contract or otherwise, arising out of or in connection with this user's guide or any other information contained herein or the use thereof.

Intended Audience

This user's guide is intended for technically qualified personnel. It is not intended for general audiences.

Symbols

The following symbols are used in this user's guide:



Warning

Warnings indicate conditions that, if not observed, can cause personal injury.



Caution

Cautions warn the user about how to prevent damage to hardware or loss of data.



Note

Notes call attention to important information that should be observed.



Connector Type

Describes the connector that must be used with the XTX Evaluation Baseboard, not the connector found on the XTX Evaluation Baseboard.



Link to connector diagram

This link icon is located in the top right corner of each page. It provides a direct link to the connector diagram on page 8 of this document.

Terminology

Term	Description
PCI Express (PCIe)	Peripheral Component Interface Express – next-generation high speed Serialized I/O bus
PCI Express Lane	One PCI Express Lane is a set of 4 signals that contains two differential lines for Transmitter and two differential lines for Receiver. Clocking information is embedded into the data stream.
x1, x2, x4	x1 refers to one PCI Express Lane of basic bandwidth; x2 to a collection of two PCI Express Lanes; etc.. Also referred to as x1, x2 or x4 link.
ExpressCard	A PCMCIA standard built on the latest USB 2.0 and PCI Express buses.
USB	Universal Serial Bus
SATA	Serial AT Attachment: serial-interface standard for hard disks
AC '97 / HDA	Audio CODEC (Coder-Decoder) / High Definition Audio
LPC	Low Pin-Count Interface: a low speed interface used for peripheral circuits such as Super I/O controllers, which typically combine legacy-device support into a single IC.
I ² C Bus	Inter-Integrated Circuit Bus: is a simple two-wire bus with a software-defined protocol that was developed to provide the communications link between integrated circuits in a system.
SM Bus	System Management Bus: is a popular derivative of the I ² C-bus.
N.C.	Not connected
N.A.	Not available
T.B.D.	To be determined

Copyright Notice

Copyright © 2005, congatec AG. All rights reserved. All text, pictures and graphics are protected by copyrights. No copying is permitted without written permission from congatec AG.

congatec AG has made every attempt to ensure that the information in this document is accurate yet the information contained within is supplied “as-is”.

Trademarks

Intel and Pentium are registered trademarks of Intel Corporation. Expresscard is a registered trademark of Personal Computer Memory Card International Association (PCMCIA). PCI Express is a registered trademark of Peripheral Component Interconnect Special Interest Group (PCI-SIG). I²C is a registered trademark of Philips Corporation. CompactFlash is a registered trademark of CompactFlash Association. STPC is a registered trademark of STMicroelectronics. LynxEM+ is a registered trademark of Silicon Motion inc. Winbond is a registered trademark of Winbond Electronics Corp. AVR is a registered trademark of Atmel Corporation. ETX is a registered trademark of JUMPTec AG. AMICORE8 is a registered trademark of American Megatrends Inc. Microsoft®, Windows®, Windows NT®, Windows CE and Windows XP® are registered trademarks of Microsoft Corporation. VxWorks is a registered trademark of WindRiver. conga, congatec and XTX are registered trademark of congatec AG. All product names and logos are property of their owners.

Warranty

congatec AG makes no representation, warranty or guaranty, express or implied regarding the products except its standard form of limited warranty ("Limited Warranty"). congatec AG may in its sole discretion modify its Limited Warranty at any time and from time to time.

Beginning on the date of shipment to its direct customer and continuing for the published warranty period, congatec AG represents that the products are new and warrants that each product failing to function properly under normal use, due to a defect in materials or workmanship or due to non conformance to the agreed upon specifications, will be repaired or exchanged, at congatec AG's option and expense.

Customer will obtain a Return Material Authorization ("RMA") number from congatec AG prior to returning the non conforming product freight prepaid. congatec AG will pay for transporting the repaired or exchanged product to the customer.

Repaired, replaced or exchanged product will be warranted for the repair warranty period in effect as of the date the repaired, exchanged or replaced product is shipped by congatec AG, or the remainder of the original warranty, whichever is longer. This Limited Warranty extends to congatec AG's direct customer only and is not assignable or transferable.

Except as set forth in writing in the Limited Warranty, congatec AG makes no performance representations, warranties, or guarantees, either express or implied, oral or written, with respect to the products, including without limitation any implied warranty (a) of merchantability, (b) of fitness for a particular purpose, or (c) arising from course of performance, course of dealing, or usage of trade.

congatec AG shall in no event be liable to the end user for collateral or consequential damages of any kind. congatec AG shall not otherwise be liable for loss, damage or expense directly or indirectly arising from the use of the product or from any other cause. The sole and exclusive remedy against congatec AG, whether a claim sound in contract, warranty, tort or any other legal theory, shall be repair or replacement of the product only

Technical Support

congatec AG technicians and engineers are committed to providing the best possible technical support for our customers so that our products can be easily used and implemented. We request that you first visit our website at www.congatec.com for the latest documentation, utilities and drivers, which have been made available to assist you. If you still require assistance after visiting our website then please contact our technical support department by email at support@congatec.com

ETX[®] Concept and XTX[™] Extension

The ETX[®] concept is an off the shelf, multi vendor, Single-Board-Computer that integrates all the core components of a common PC and is mounted onto an application specific baseboard. ETX[®] modules have a standardized form factor of just 95mm x 114mm and have identical pinouts on the four system connectors. The ETX[®] module provides most of the functional requirements for any application. These functions include, but are not limited to, graphics, sound, keyboard/mouse, IDE, Ethernet, parallel, serial and USB ports. Four ruggedized connectors provide the baseboard interface and carry all the I/O signals to and from the ETX[®] module.

Baseboard designers can utilize as little or as many of the I/O interfaces as deemed necessary. The baseboard can therefore provide all the interface connectors required to attach the system to the application specific peripherals. This versatility allows the designer to create a dense and optimized package, which results in a more reliable product while simplifying system integration. Most importantly ETX[®] applications are scalable, which means once a product has been created there is the ability to diversify the product range through the use of different performance class ETX[®] modules. Simply unplug one module and replace it with another, no redesign is necessary.

XTX[™] is an expansion and continuation of the well-established and highly successful ETX[®] standard. XTX[™] offers the newest I/O technologies on this proven form factor. Now that the ISA bus is being used less and less in modern embedded applications congatec AG offers an array of different features on the X2 connector than those currently found on the ETX[®] platform. These features include new serial high speed buses such as PCI Express[™] and Serial ATA[®]. All other signals found on connectors X1, X3, and X4 remain the same in accordance to the ETX[®] standard (Rev. 2.7) and therefore will be completely compatible. If the embedded PC application still requires the ISA bus then an ISA bridge can be implemented on the application specific baseboard or the readily available LPC bus located on the XTX[™] module may be used. Please contact congatec technical support for details.

Lead-Free Designs (RoHS)

As of July 2006 all electronic products are required to be environmentally friendly. In future, many of the currently available embedded computer modules will not be offered as lead-free variants. For this reason all congatec AG designs are created from lead-free components and are completely RoHS compliant. This makes congatec AG products ideal lead-free substitutes for new and existing designs.

Certification

congatec AG is certified to DIN EN ISO 9001:2000 standard.



Contents

1 Connector Diagram.....	8
2 Specifications.....	9
2.1 Mechanical Dimensions.....	9
2.2 Power Supply.....	9
2.3 CMOS Battery.....	10
2.4 Environmental Specifications.....	10
3 Connector Description.....	11
3.1 XTX Module Connector	11
3.1.1 Connector X1 (PCI Bus, USB, Audio).....	11
3.1.2 Connector X2 (PCIe, SATA, USB, ExpressCard, AC'97/HDA, LPC, ...).....	12
3.1.3 Connector X3 (VGA, LCD, Video, COM1, COM2, LPT/Floppy, IrDA, Mouse, Keyboard).....	13
3.1.4 Connector X4 (IDE 1, IDE 2, Ethernet, Miscellaneous).....	15
3.2 Subsystems of XTX Connector X1.....	16
3.2.1 PCI Bus.....	16
3.2.2 Universal Serial Bus (USB).....	16
3.2.3 XTX Module Audio.....	17
3.3 Subsystems of XTX Connector X2.....	17
3.3.1 PCI Express™ x1 Connectors.....	17
3.3.2 Serial ATA™	18
3.3.3 ExpressCard™	18
3.3.4 AC'97/HDA Audio.....	19
3.3.5 Low Pin Count Bus (LPC).....	20
3.3.6 Fan Connector and Power Configuration.....	21
3.4 Subsystems of XTX Connector X3.....	22
3.4.1 VGA Output, Serial Ports and Parallel Port / Floppy.....	22
3.4.2 Flat Panel Interface.....	23
3.4.3 TV Interface.....	26
3.4.4 Serial Infrared Interface (IrDA).....	26
3.4.5 PS/2 Mouse and Keyboard.....	26
3.5 Subsystems of XTX Connector X4.....	27
3.5.1 IDE.....	27
3.5.2 Ethernet.....	27
3.5.3 Feature Connector.....	28
3.5.4 I2C Bus	28
4 Additional Features.....	29
4.1 Reset	29
4.2 PC Speaker (Beeper).....	29
4.3 Debug Display.....	29
4.4 Ground Test Points.....	30
5 Mechanical Drawing conga-XEVAL.....	31
6 Industry Specifications.....	32

1 Connector Diagram

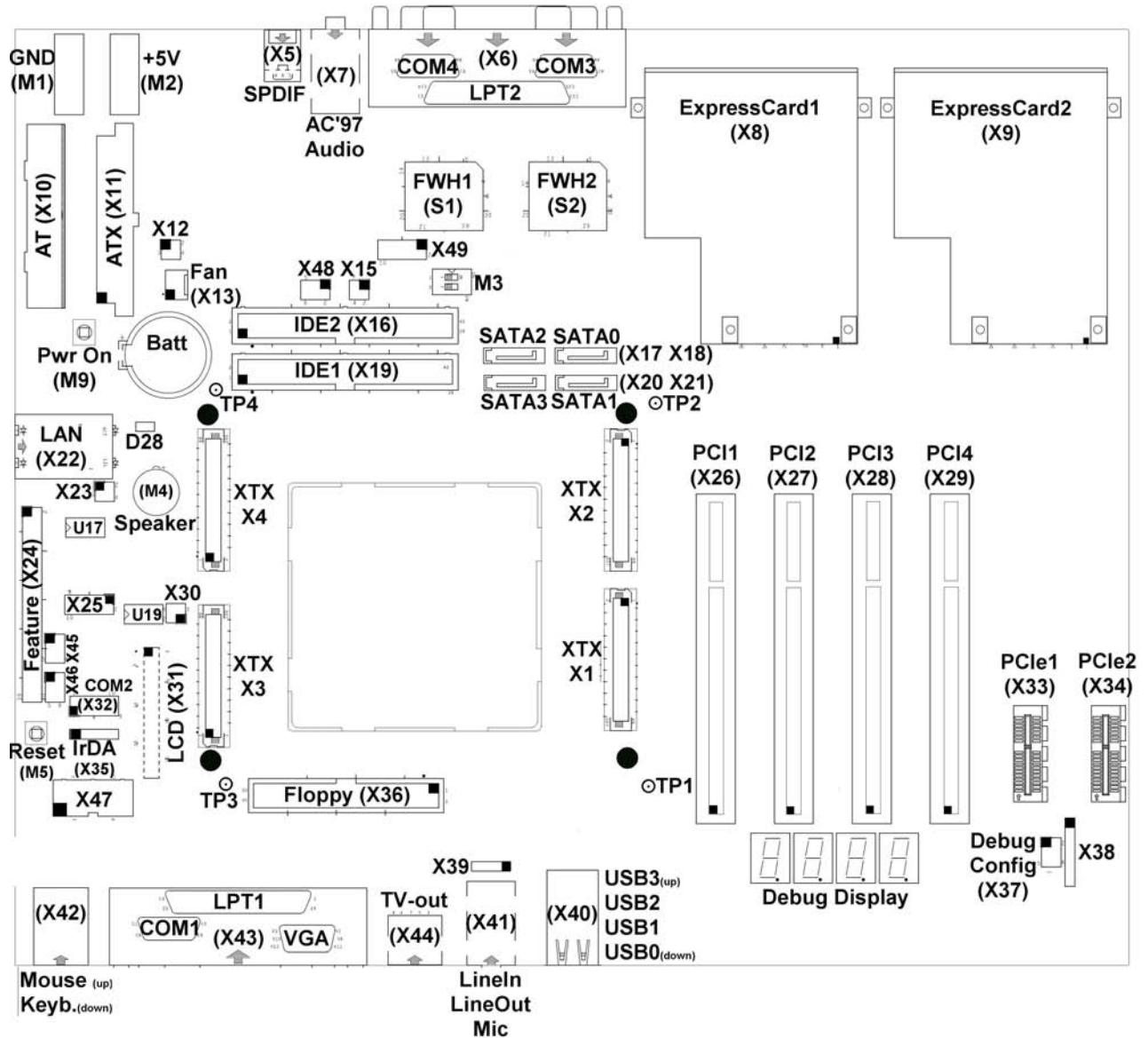

 **Note:** Pin 1 is marked on the bottom of the XTX Evaluation Baseboard with a quadratic pad. The table below lists the connector (Con.) and page links (Page) to its description.

Con.	Page	Con.	Page	Con.	Page	Con.	Page	Con.	Page	Con.	Page	Con.	Page
X1	11	X7	19	X13/X48	21	X23	27	X32/X43	22	X39/X41	17	M1-M2	9
X2	12	X8	18	X15	19	X24	28	X33-34	17	X40	16	M3	21
X3	13	X9	18	X16/X19	27	X25	28	X35	26	X42	26	Batt	10
X4	15	X10	9	X17-18	18	X26-29	16	X36	23	X44	26	M4-5	29
X5	19	X11	9	X20-21	18	X30	22	X37	30	X45-46	24	M9	9
X6/X49	20	X12	9	X22	27	X31	23	X38	30	X47	24	TP1-4	30



2 Specifications

2.1 Mechanical Dimensions

- 294.0mm x 244.0mm
- Height approx. 44mm

2.2 Power Supply

The XTX Evaluation baseboards can be used with standard AT (Connector X10) or ATX (Connector X11) power supplies.

When using an ATX power supply, the XTX module will start after the power-on button M9 is pressed. The ATX power supply can also be used in AT mode. In this case the module will start after the power switch on the power supply is turned on.

**Pwr On
(M9)**

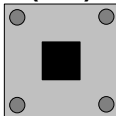

**ATX / AT
(X12)**



Jumper X12	Configuration
1 - 2	ATX Power supply
3 - 4	ATX Power supply runs in AT mode



Connector Type

X12: 2.54mm grid jumper.

The XTX Evaluation Baseboard can also be used with 5V power supply (connector M1 and M2). In this case the +12V power supply for Fan and LCD Backlight is not available. The +3.3V used by some devices on the XTX Evaluation Baseboard is generated onboard from the 5V power supply.

**GND
(M1)** **+5V
(M2)**

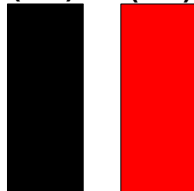

Connector	Configuration
M1	Ground
M2	+5VDC, ±5%



Connector Type

4mm diameter plug



2.3 CMOS Battery

The XTX Evaluation Baseboard includes a battery that supplies the RTC and CMOS memory of the XTX CPU module. The battery needs to provide a power of 3V. The specified battery type is CR2032.



Warning

Danger of explosion if battery is incorrectly replaced. Replace only with the same or equivalent type recommended by the manufacturer. Dispose of used batteries according to the manufacturer's instructions.

To fulfill the requirements of the EN60950, the XTX Evaluation Baseboard incorporates two current-limiting devices (resistor and diode) in the battery power supply path.

2.4 Environmental Specifications

Temperature Operation: 0° to 60°C Storage: -20° to +80°C

Humidity Operation: 10% to 90% Storage: 5% to 95%



Note

The above operating temperatures must be strictly adhered to at all times. The maximum operating temperature refers to any measurable spot on the modules surface.

Humidity specifications are for non-condensing conditions.



3 Connector Description

3.1 XTX Module Connector

3.1.1 Connector X1 (PCI Bus, USB, Audio)

Pin	Signal	Description	Pin	Signal	Description
1	GND	Power Ground	2	GND	Power Ground
3	PCICLK3	PCI Clock output 3	4	PCICLK4	PCI Clock output 4
5	GND	Power Ground	6	GND	Power Ground
7	PCICLK1	PCI Clock output 1	8	PCICLK2	PCI Clock output 2
9	REQ3#	PCI Bus request 3	10	GNT3#	PCI Bus grant 3
11	GNT2#	PCI Bus grant 2	12	3V	Power Supply +3.3VDC
13	REQ2#	PCI Bus request 2	14	GNT1#	PCI Bus grant 1
15	REQ1#	PCI Bus request 1	16	3V	Power Supply +3.3VDC
17	GNT0#	PCI Bus grant 0	18	RESERVED	
19	VCC	Power Supply +5VDC, ±5%	20	VCC	Power Supply +5VDC, ±5%
21	SERIRQ	Serial Interrupt request	22	REQ0#	PCI Bus request 0
23	AD0	PCI Address/Data bus line 0	24	3V	Power Supply +3.3VDC
25	AD1	PCI Address/Data bus line 1	26	AD2	PCI Address/Data bus line 2
27	AD4	PCI Address/Data bus line 4	28	AD3	PCI Address/Data bus line 3
29	AD6	PCI Address/Data bus line 6	30	AD5	PCI Address/Data bus line 5
31	CBE0#	PCI Bus command/byte enables 0	32	AD7	PCI Address/Data bus line 7
33	AD8	PCI Address/Data bus line 8	34	AD9	PCI Address/Data bus line 9
35	GND	Power Ground	36	GND	Power Ground
37	AD10	PCI Address/Data bus line 10	38	AUXAL	Audio Auxiliary input A left
39	AD11	PCI Address/Data bus line 11	40	MIC	Microphone input
41	AD12	PCI Address/Data bus line 12	42	AUXAR	Audio Auxiliary input A right
43	AD13	PCI Address/Data bus line 13	44	ASVCC	Analog supply of sound controller
45	AD14	PCI Address/Data bus line 14	46	SNDL	Audio Line-Level stereo output left
47	AD15	PCI Address/Data bus line 15	48	ASGND	Analog ground of sound controller
49	CBE1#	PCI Bus command/byte enables 1	50	SNDR	Audio Line-Level stereo output right
51	VCC	Power Supply +5VDC, ±5%	52	VCC	Power Supply +5VDC, ±5%
53	PAR	PCI Bus parity	54	SERR#	PCI Bus system error
55	GPERR#	PCI Bus grant parity error	56	RESERVED	
57	PME#	PCI Bus power management event	58	USB2#	USB Port 2, data - or D-
59	LOCK#	PCI Bus lock	60	DEVSEL#	PCI Bus device select
61	TRDY#	PCI Bus target ready	62	USB3#	USB Port 3, data - or D-
63	IRDY#	PCI Bus initiator ready	64	STOP#	PCI Bus stop
65	FRAME#	PCI Bus frame	66	USB2	USB Port 2, data + or D+
67	GND	Power Ground	68	GND	Power Ground
69	AD16	PCI Address/Data bus line 16	70	CBE2#	PCI Bus command/byte enables 2
71	AD17	PCI Address/Data bus line 17	72	USB3	USB Port 3, data + or D+
73	AD19	PCI Address/Data bus line 19	74	AD18	PCI Address/Data bus line 18
75	AD20	PCI Address/Data bus line 20	76	USB0#	USB Port 0, data - or D-
77	AD22	PCI Address/Data bus line 22	78	AD21	PCI Address/Data bus line 21
79	AD23	PCI Address/Data bus line 23	80	USB1#	USB Port 1, data - or D-
81	AD24	PCI Address/Data bus line 24	82	CBE3#	PCI Bus command/byte enables 3
83	VCC	Power Supply +5VDC, ±5%	84	VCC	Power Supply +5VDC, ±5%
85	AD25	PCI Address/Data bus line 25	86	AD26	PCI Address/Data bus line 26
87	AD28	PCI Address/Data bus line 28	88	USB0	USB Port 0, data + or D+
89	AD27	PCI Address/Data bus line 27	90	AD29	PCI Address/Data bus line 29
91	AD30	PCI Address/Data bus line 30	92	USB1	USB Port 1, data + or D+
93	PCIRST#	PCI Bus reset	94	AD31	PCI Address/Data bus line 31
95	INTC#	PCI Bus interrupt C	96	INTD#	PCI Bus interrupt D
97	INTA#	PCI Bus interrupt A	98	INTB#	PCI Bus interrupt B
99	GND	Power Ground	100	GND	Power Ground

3.1.2 Connector X2 (PCIe, SATA, USB, ExpressCard, AC'97/HDA, LPC, ...)



Pin	Signal	Description	Pin	Signal	Description
1	GND	Power Ground	2	GND	Power Ground
3	PCIE_CLK_REF+	PCI Express Reference Clock, positive differential line	4	SATA0_RX+	Serial ATA channel 0, receive input, positive diff. line
5	PCIE_CLK_REF-	PCI Express Reference Clock, negative differential line	6	SATA0_RX-	Serial ATA channel 0, receive input, negative diff. line
7	GND	Power Ground	8	GND	Power Ground
9	PCIE3_TX+	PCI Express lane 3, transmit output, positive line	10	SATA0_TX-	Serial ATA channel 0, transmit output, negative diff. line
11	PCIE3_TX-	PCI Express lane 3, transmit output, negative line	12	SATA0_TX+	Serial ATA channel 0, transmit output, positive diff. line
13	GND	Power Ground	14	5V_SB	Supply of internal suspend circuit
15	PCIE3_RX+	PCI Express lane 3, receive input, positive line	16	SATA1_RX+	Serial ATA channel 1, receive input, positive diff. line
17	PCIE3_RX-	PCI Express lane 3, receive input, negative line	18	SATA1_RX-	Serial ATA channel 1, receive input, negative diff. line
19	VCC	Power Supply +5VDC, ±5%	20	5V_SB	Supply of internal suspend circuit
21	EXC1_CPPE#	ExpressCard capable card request for slot 2	22	SATA1_TX-	Serial ATA channel 1, transmit output, negative diff. line
23	EXC1_RST#	ExpressCard Reset for slot 2	24	SATA1_TX+	Serial ATA channel 1, transmit output, positive diff. line
25	USBP5	Universal Serial Bus Port 5, positive differential line	26	GND	Power Ground
27	USBP5#	Universal Serial Bus Port 5, negative differential line	28	SATA2_RX+	Serial ATA channel 2, receive input, positive diff. line
29	GND	Power Ground	30	SATA2_RX-	Serial ATA channel 2, receive input, negative diff. line
31	PCIE2_TX+	PCI Express lane 2, transmit output, positive diff. line	32	SUS_STAT#	Suspend Status
33	PCIE2_TX-	PCI Express lane 2, transmit output, negative diff. line	34	RESERVED	N.C.
35	GND	Power Ground	36	GND	Power Ground
37	PCIE2_RX+	PCI Express lane 2, receive input, positive diff. line	38	SATA2_TX-	Serial ATA channel 2, transmit output, negative diff. line
39	PCIE2_RX-	PCI Express lane 2, receive input, negative diff. line	40	SATA2_TX+	Serial ATA channel 2, transmit output, positive diff. line
41	EXC0_CPPE#	ExpressCard capable card request for slot 1	42	GND	Power Ground
43	EXC0_RST#	ExpressCard Reset for slot 1	44	SATA3_RX+	Serial ATA channel 3, receive input, positive diff. line
45	USBP4	Universal Serial Bus Port 4, positive differential line	46	SATA3_RX-	Serial ATA channel 3, receive input, negative diff. line
47	USBP4#	Universal Serial Bus Port 4, negative differential line	48	WDTRIG	Watch Dog Trigger input
49	SLP_S3#	S3 (Suspend to RAM) Sleep Control	50	SATALED#	Serial ATA activity LED
51	VCC	Power Supply +5VDC, ±5%	52	VCC	Power Supply +5VDC, ±5%
53	PCIE1_RX-	PCI Express lane 1, receive input, negative diff. line	54	SATA3_TX-	Serial ATA channel 3, transmit output, negative diff. line
55	PCIE1_RX+	PCI Express lane 1, receive input, positive diff. line	56	SATA3_TX+	Serial ATA channel 3, transmit output, positive diff. line
57	GND	Power Ground	58	IL_SATA#	Serial ATA Interlock Switch Input
59	PCIE1_TX-	PCI Express lane 1, transmit output, negative diff. line	60	RESERVED	N.C.
61	PCIE1_TX+	PCI Express lane 1, transmit output, positive diff. line	62	RESERVED	N.C.
63	PCE_WAKE#	PCI Express Wake Event	64	PCI_GNT#A	Reserved
65	RESERVED	N.C.	66	PCI_REQ#A	Reserved
67	GND	Power Ground	68	GND	Power Ground
69	PCIE0_RX-	PCI Express channel 0,	70	RESERVED	N.C.

Pin	Signal	Description	Pin	Signal	Description
		receive input, negative diff. line			
71	PCIE0_RX+	PCI Express channel 0, receive input, positive line	72	RESERVED	N.C.
73	GND	Power Ground	74	VCC	Power Supply +5VDC, ±5%
75	PCIE0_TX-	PCI Express channel 0, transmit output, negative line	76	RESERVED	N.C.
77	PCIE0_TX+	PCI Express channel 0, transmit output, positive line	78	RESERVED	N.C.
79	CODECSET	AC'97/HDA Disable onboard Audio Codec	80	VCC	Power Supply +5VDC, ±5%
81	AC_RST#	AC'97/HDA CODEC Reset	82	AC_SDOUT	AC'97/HDA Audio Serial Data Output to CODEC
83	VCC	Power Supply +5VDC, ±5%	84	VCC	Power Supply +5VDC, ±5%
85	AC_SYNC	AC'97/HDA Serial Bus Synchronization	86	AC_SDIN0	AC'97/HDA Audio Serial Data Input from CODEC0
87	AC_SDIN1	AC'97/HDA Audio Serial Data Input from CODEC1	88	AC_SDIN2	AC'97/HDA Audio Serial Data Input from CODEC2
89	AC_BIT_CLK	AC'97/HDA 12.228 MHz Serial Bit Clock from CODEC	90	FAN_TACHOIN	Fan tachometer input
91	LPC_AD0	LPC Multiplexed Command, Address and Data line 0	92	FAN_PWMOUT	Fan speed control
93	LPC_AD1	LPC Multiplexed Command, Address and Data line 1	94	LPC_FRAME#	LPC Frame: Indicates start of a new or termination of a broken cycle
95	LPC_AD2	LPC Multiplexed Command, Address and Data line 2	96	LPC_DRQ0#	LPC Encoded DMA/Bus Master Request line 0
97	LPC_AD3	LPC Multiplexed Command, Address and Data line 3	98	LPC_DRQ1#	LPC Encoded DMA/Bus Master Request line 1
99	GND	Power Ground	100	GND	Power Ground

3.1.3 Connector X3 (VGA, LCD, Video, COM1, COM2, LPT/Floppy, IrDA, Mouse, Keyboard)

Pin	Signal	Description	Pin	Signal	Description
1	GND	Power Ground	2	GND	Power Ground
3	R	CRT Red channel RGB Analog Video Output	4	B	CRT Blue channel RGB Analog Video Output
5	HSY	CRT Horizontal Synchronization Pulse	6	G	CRT Green channel RGB Analog Video Output
7	VSY	CRT Vertical Synchronization Pulse	8	DDCK	CRT Display Data Channel Clock
9	DETECT#	Panel hot-plug detection	10	DDDA	CRT Display Data Channel Data
11	LCDDO16 / B4*	LVDS channel data line 16 / TTL RGB signal Blue 4	12	LCDDO18 / SHFCLK*	LVDS channel data line 18 / TTL Panel data clock
13	LCDDO17 / B5*	LVDS channel data line 17 / TTL RGB signal Blue 5	14	LCDDO19 / EN*	LVDS channel data line 19 / TTL Data-enable signal
15	GND	Power Ground	16	GND	Power Ground
17	LCDDO13 / B1*	LVDS channel data line 13 / TTL RGB signal Blue 1	18	LCDDO15 / B3*	LVDS channel data line 15 / TTL RGB signal Blue 3
19	LCDDO12 / B0*	LVDS channel data line 12 / TTL RGB signal Blue 0	20	LCDDO14 / B2*	LVDS channel data line 14 / TTL RGB signal Blue 2
21	GND	Power Ground	22	GND	Power Ground
23	LCDDO8 / G2*	LVDS channel data line 8 / TTL RGB signal Green 2	24	LCDDO11 / G5*	LVDS channel data line 11 / TTL RGB signal Green 5
25	LCDDO9 / G3*	LVDS channel data line 9 / TTL RGB signal Green 3	26	LCDDO10 / G4*	LVDS channel data line 10 / TTL RGB signal Green 4
27	GND	Power Ground	28	GND	Power Ground
29	LCDDO4 / R4*	LVDS channel data line 4 / TTL RGB signal Red 4	30	LCDDO7 / G1*	LVDS channel data line 7 / TTL RGB signal Green 1
31	LCDDO5 / R5*	LVDS channel data line 5 / TTL RGB signal Red 5	32	LCDDO6 / G0*	LVDS channel data line 6 / TTL RGB signal Green 0
33	GND	Power Ground	34	GND	Power Ground
35	LCDDO1 /	LVDS channel data line 1 /	36	LCDDO3 /	LVDS channel data line 3 /

Pin	Signal	Description	Pin	Signal	Description
	R1*	TTL RGB signal Red 1		R3*	TTL RGB signal Red 3
37	LCDDO0 / R0*	LVDS channel data line 0 / TTL RGB Signals Red 0	38	LCDDO2 / R2*	LVDS channel data line 2 / TTL RGB signal Red 2
39	VCC	Power Supply +5VDC, ±5%	40	VCC	Power Supply +5VDC, ±5%
41	FPDDC_DAT	LCD Display Data Channel Data	42	LTGIO0 / VSYNC*	General Purpose I O / Vertical synchronization pulse
43	FPDDC_CLK	LCD Display Data Channel Clock	44	BLON#	Controls display Backlight
45	BIASON / HSYNC*	Controls display contrast voltage / TTL Horizontal synchronization pulse	46	DIGON	Controls display Power
47	COMP	TV Composite Video or Blue for RGB Video	48	Y	TV Luminance for S-Video or Red for RGB Video
49	SYNC	TV Composite sync for RGB Video	50	C	TV Chrominance for S-Video or Green for RGB Video
51	LPT / FLPY#	Not supported	52	RESERVED	N.C.
53	VCC	Power Supply +5VDC, ±5%	54	GND	Power Ground
55	STB# / RESERVED**	LPC Strobe signal / N.C.	56	AFD / DENSEL**	LPT Automatic feed / FLPY Indicates low or high data rate
57	RESERVED	N.C.	58	PD7 / RESERVED**	LPT Data bus D7 / N.C.
59	IRRX	Infrared Receive	60	ERR# / HDSEL#**	LPT error / FLPY Head select
61	IRTX	Infrared Transmit	62	PD6 / RESERVED**	LPT Data bus D6 / N.C.
63	RXD2	Data receive for COM2	64	INIT# / DIR#**	LPT Initiate / FLPY Direction
65	GND	Power Ground	66	GND	Power Ground
67	RTS2#	Request to send for COM2	68	PD5 / RESERVED*	LPT Data bus D5 / N.C.
69	DTR2#	Data terminal ready for COM2	70	SLIN# / STEP#**	LPT Select / FLPY Motor step
71	DCD2#	Data carrier detect for COM2	72	PD4 / DSKCHG#**	LPT Data bus D4 / FLPY Disk change
73	DSR2#	Data set ready for COM2	74	PD3 / RDATA#**	LPT Data bus D3 / FLPY Raw data read
75	CTS2#	Clear to send for COM2	76	PD2 / WP#**	LPT Data bus D2 / FLPY Write protect signal
77	TXD2	Data transmit for COM2	78	PD1 / TRK0#**	LPT Data bus D1 / FLPY Track signal
79	RI2#	Ring indicator for COM2	80	PD0 / INDEX#**	LPT Data bus D0 / FLPY Index signal
81	VCC	Power Supply +5VDC, ±5%	82	VCC	Power Supply +5VDC, ±5%
83	RXD1	Data receive for COM1	84	ACK# / DRV**	LPT Acknowledge / FLPY Drive select
85	RTS1#	Request to send for COM1	86	BUSI / MOT**	LPT Busy / FLPY Motor select
87	DTR1#	Data terminal ready for COM1	88	PE / WDATA#**	LPT Paper empty / FLPY Raw write data
89	DCD1#	Data carrier detect for COM1	90	SLCT / WGATE#**	LPT Power On / FLPY Write enable
91	DSR1#	Data set ready for COM1	92	MSCLK	Mouse Clock
93	CTS1#	Clear to send for COM1	94	MSDAT	Mouse Data
95	TXD1	Data transmit for COM1	96	KBCLK	Keyboard Clock
97	RI1#	Ring indicator for COM1	98	KBDAT	Keyboard Data
99	GND	Power Ground	100	GND	Power Ground

Note



* Configuration for TTL Flat Panel output, otherwise LVDS output.

** Configuration for Floppy output, otherwise LPT output.

3.1.4 Connector X4 (IDE 1, IDE 2, Ethernet, Miscellaneous)



Pin	Signal	Description	Pin	Signal	Description
1	GND	Power Ground	2	GND	Power Ground
3	5V_SB	Supply of internal suspend circuit	4	PWGIN	Power good input
5	PS_ON#	Power Save ON	6	SPEAKER	Speaker output
7	PWRBTN#	Power Button	8	BATT	Battery supply
9	KBINH#	Keyboard inhibit	10	LILED#	Ethernet link LED
11	RSMRST#	Resume Reset input	12	ACTLED#	Ethernet activity LED
13	ROMKBCS#	Internal use. Do not connect	14	SPEEDLED#	Ethernet speed LED
15	EXT_PRG	Internal use. Do not connect	16	I2CLK	I ² C Bus Clock
17	VCC	Power Supply +5VDC, ±5%	18	VCC	Power Supply +5VDC, ±5%
19	OVCR#	USB Over current detection	20	GPCS#	General purpose chip select
21	EXTSMI#	System management interrupt input	22	I2DAT	I ² C Bus Data
23	SMBCLK	SM Bus Clock	24	SMBDATA	SM Bus Data
25	SIDE_CS3#	Secondary IDE chip select 3	26	SMBALRT#	SM Bus Alert input
27	SIDE_CS1#	Secondary IDE chip select 1	28	DASP_S	Secondary IDE Drive active
29	SIDE_A2	Secondary IDE Address line 2	30	PIDE_CS3#	Primary IDE chip select 3
31	SIDE_A0	Secondary IDE Address line 0	32	PIDE_CS1#	Primary IDE chip select 1
33	GND	Power Ground	34	GND	Power Ground
35	PDIAG_S	Sec. IDE Master/Slave negotiation	36	PIDE_A2	Primary IDE Address line 2
37	SIDE_A1	Secondary IDE Address line 1	38	PIDE_A0	Primary IDE Address line 0
39	SIDE_INTRQ	Secondary IDE interrupt request	40	PIDE_A1	Primary IDE Address line 1
41	BATLOW#	Battery low input	42	GPE1#	General purpose power management event input 1
43	SIDE_AK#	Secondary IDE DMA acknowledge	44	PIDE_INTRQ	Primary IDE interrupt request
45	SIDE_RDY	Secondary IDE ready	46	PIDE_AK#	Primary IDE DMA acknowledge
47	SIDE_IOR#	Secondary IDE IO read	48	PIDE_RDY	Primary IDE ready
49	VCC	Power Supply +5VDC, ±5%	50	VCC	Power Supply +5VDC, ±5%
51	SIDE_IOW#	Secondary IDE IO write	52	PIDE_IOR#	Primary IDE IO read
53	SIDE_DRQ	Secondary IDE DMA request	54	PIDE_IOW#	Primary IDE IO write
55	SIDE_D15	Secondary IDE Data line 15	56	PIDE_DRQ	Primary IDE DMA request
57	SIDE_D0	Secondary IDE Data line 0	58	PIDE_D15	Primary IDE Data line 15
59	SIDE_D14	Secondary IDE Data line 14	60	PIDE_D0	Primary IDE Data line 0
61	SIDE_D1	Secondary IDE Data line 1	62	PIDE_D14	Primary IDE Data line 14
63	SIDE_D13	Secondary IDE Data line 13	64	PIDE_D1	Primary IDE Data line 1
65	GND	Power Ground	66	GND	Power Ground
67	SIDE_D2	Secondary IDE Data line 2	68	PIDE_D13	Primary IDE Data line 13
69	SIDE_D12	Secondary IDE Data line 12	70	PIDE_D2	Primary IDE Data line 2
71	SIDE_D3	Secondary IDE Data line 3	72	PIDE_D12	Primary IDE Data line 12
73	SIDE_D11	Secondary IDE Data line 11	74	PIDE_D3	Primary IDE Data line 3
75	SIDE_D4	Secondary IDE Data line 4	76	PIDE_D11	Primary IDE Data line 11
77	SIDE_D10	Secondary IDE Data line 10	78	PIDE_D4	Primary IDE Data line 4
79	SIDE_D5	Secondary IDE Data line 5	80	PIDE_D10	Primary IDE Data line 10
81	VCC	Power Supply +5VDC, ±5%	82	VCC	Power Supply +5VDC, ±5%
83	SIDE_D9	Secondary IDE Data line 9	84	PIDE_D5	Primary IDE Data line 5
85	SIDE_D6	Secondary IDE Data line 6	86	PIDE_D9	Primary IDE Data line 9
87	SIDE_D8	Secondary IDE Data line 8	88	PIDE_D6	Primary IDE Data line 6
89	GPE2#	General purpose power management event input 2	90	CBLID_P#	Primary cable ID for DMA66 or DMA100 transfer modes
91	RXD#	Ethernet Twisted Pair receive, negative signal	92	PIDE_D8	Primary IDE Data line 8
93	RXD	Ethernet Twisted Pair receive, positive signal	94	SIDE_D7	Secondary IDE Data line 7
95	TXD#	Ethernet Twisted Pair transmit negative signal	96	PIDE_D7	Primary IDE Data line 7
97	TXD	Ethernet Twisted Pair transmit positive signal	98	HDRST#	Hard Drive reset
99	GND	Power Ground	100	GND	Power Ground



3.2 Subsystems of XTX Connector X1

3.2.1 PCI Bus

This chapter only describes the interrupt routing for the 4 PCI slots used on the XTX Evaluation baseboard. A detailed pin description of the PCI connector can be found in the XTX Design Guide.

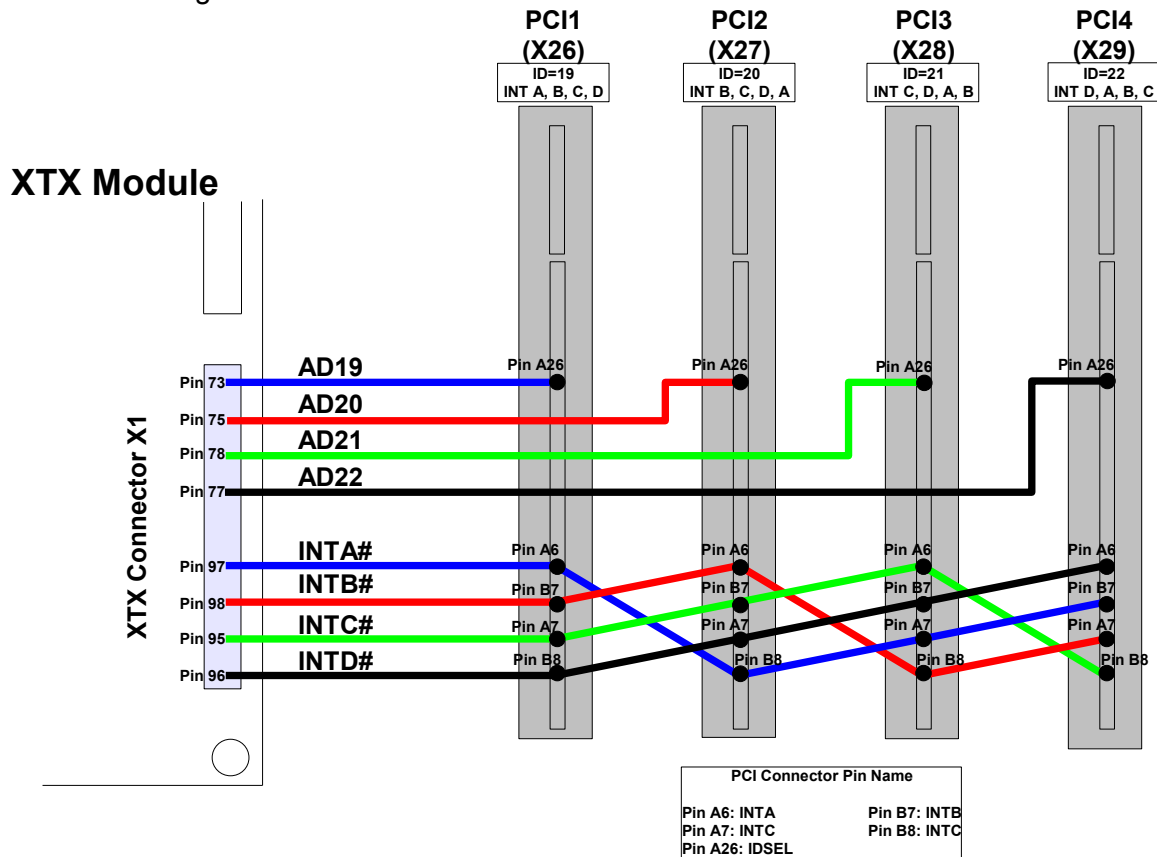

3.2.2 Universal Serial Bus (USB)

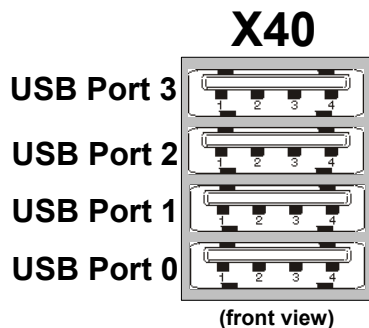

Pin	Signal
1	+5V
2	DATA-
3	DATA+
4	GND



3.2.3 XTX Module Audio

The audio signals provided by the XTX module are available on following connectors.

XTX Audio (X41)

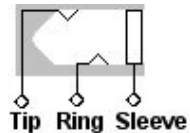
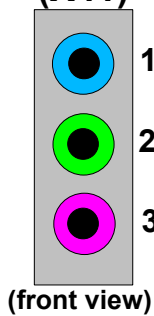

X39

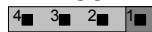

Stereo Jack 1	Signal
Tip	Line Input Left
Ring	Line Input Right
Sleeve	Ground

Stereo Jack 2	Signal
Tip	Line Output Left
Ring	Line Output Right
Sleeve	Ground

Stereo Jack 3	Signal
Tip	Microphone Input
Ring	+5V Microphone Bias Power
Sleeve	Analog Ground

Pin	Signal
1	Line Input Left
2	Analog Ground
3	Analog Ground
4	Line Input Right



Connector Type

X41: 3.5mm stereo plug,

X39: 4 pin, 1 row 2.54mm grid female.

3.3 Subsystems of XTX Connector X2

3.3.1 PCI Express™ x1 Connectors

A detailed pin description of the PCI connector can be found in the XTX Design Guide.

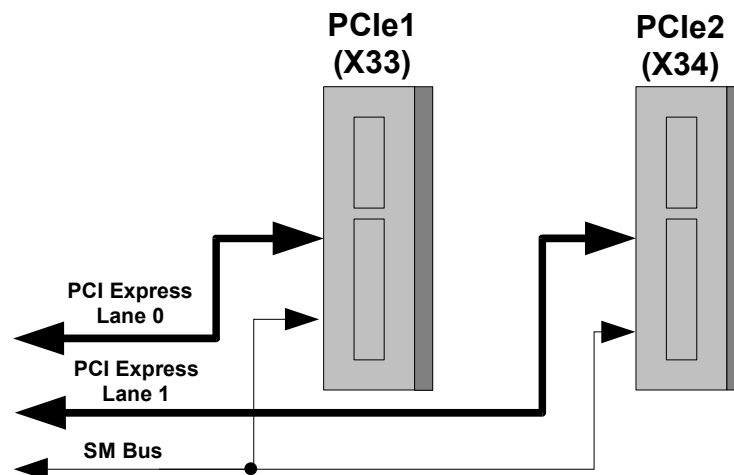

 **Note**

The JTAG Interface is not available on the two PCI Express connectors PCIe1 and PCIe2.

3.3.2 Serial ATA™

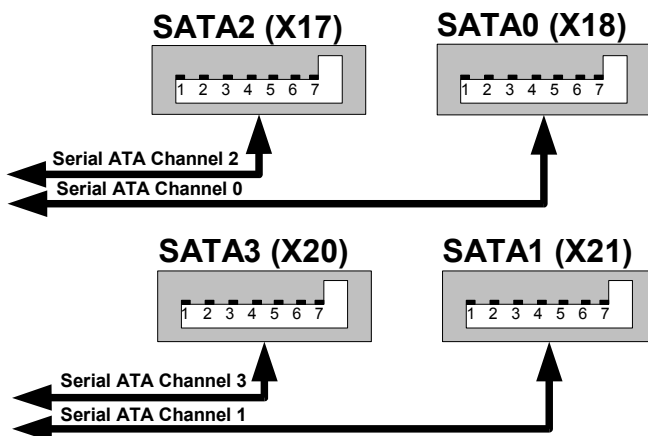

Pin	Signal
1	GND
2	TX+
3	TX-
4	GND
5	RX+
6	RX-
7	GND

3.3.3 ExpressCard™

The XTX Evaluation baseboard supports two ExpressCard slots. A detailed pin description of the ExpressCard connector can be found in the XTX Design Guide.

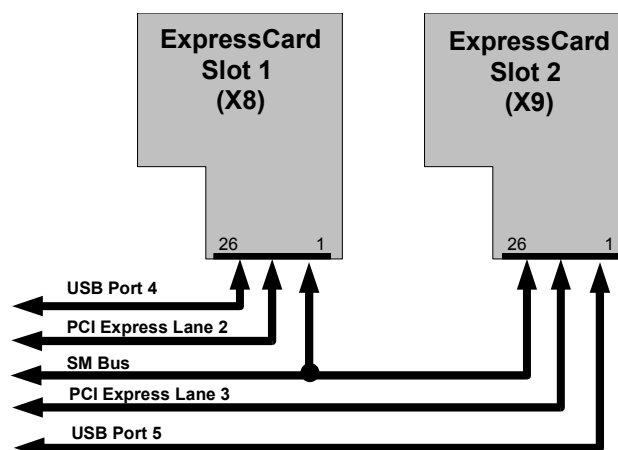

The XTX Evaluation Baseboard supports ExpressCard/34 and ExpressCard/54 types.



3.3.4 AC'97/HDA Audio

The XTX evaluation baseboard has an AC'97 Audio Codec (VIA VT1616) mounted. The stereo audio output and optical S/PDIF interface of this codec is available on the connectors described below. The Windows driver for this audio codec can be found on the congatec website at www.congatec.com in the 'Products' section under 'Accessories'. There is also a jumper (X15) on the XTX evaluation baseboard that allows you to choose to use either the XTX CPU module's onboard audio codec or the XTX evaluation baseboard's audio codec. You must choose which one to use, both cannot be used at the same time. The XTX CPU module's onboard audio codec is enabled by default. The jumper (X15) configuration is described below.

The XTX evaluation baseboard AC'97 codec can be used in two different modes; either stereo or 5.1 audio mode. The modes can be changed in the audio codec driver.

AC'97 Audio (X7)

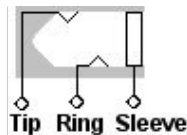
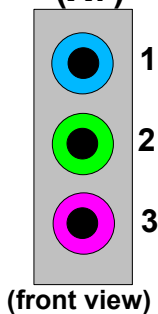

Stereo Jack 1	Stereo Mode	5.1 Channel Mode
Tip	Line Input Left	Rear Channel Output Left
Ring	Line Input Right	Rear Channel Output Right
Sleeve	Ground	Ground

Stereo Jack 2	Stereo Mode	5.1 Channel Mode
Tip	Line Output Left	Front Channel Output Left
Ring	Line Output Right	Front Channel Output Right
Sleeve	Ground	Ground

Stereo Jack 3	Stereo Mode	5.1 Channel Mode
Tip	Microphone*	Center Output
Ring	Not used	Low Frequency Effects Output (Sub Woofer)
Sleeve	Ground	Ground



Connector Type

3.5mm stereo plug.



*Note

Only mono microphones can be used on the XTX Evaluation baseboard.

S/PDIF (X5)

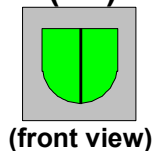

Connector Type

Optical Toslink plug.

Jumper (X15)



Jumper X15	Configuration
1 - 2	XTX evaluation baseboard audio codec
3 - 4	XTX module CPU audio codec (default)



Connector Type

X15: 2.54mm grid jumper.



3.3.5 Low Pin Count Bus (LPC)

The X49 connector is intended for internal use. LPC devices must be supported by the CPU BIOS. Please contact the congatec AG support for further information.



Note

Connector X49 is intended for internal use.

LPC Super I/O device

The XTX Evaluation Baseboard integrates a Super I/O controller that provides additional interfaces such as two serial ports and a parallel port. The Winbond W83627HG controller is connected to the LPC Bus of the XTX module.

The interfaces provided by this Super I/O controller are available on the X6 connector. Serial port COM3 follows the RS232 standard while the signals of COM4 are transformed on the XTX Baseboard to follow the RS485/RS422 standard.

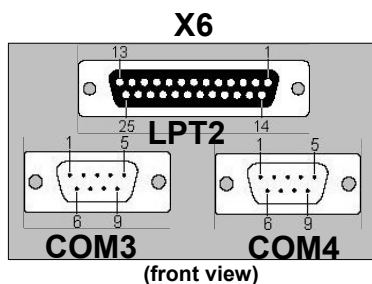

For the pinout of the LPT2 and COM ports 3 and 4, see the table below.



Connector Type

COM: 9 pin D-SUB, female,

LPT: 24 pin D-SUB, male.

Pin	LPT2	COM3	COM4
1	STROBE#	DCD#	TXD+
2	PD0	RXD	
3	PD1	TXD	TXD-
4	PD2	DTR#	
5	PD3	GND	GND
6	PD4	DSR	RXD+
7	PD5	RTS#	
8	PD6	CTS#	RXD-
9	PD7	RI#	
10	ACK#		
11	BUSY		
12	PE		
13	SEL		
14	AUTOFD#		
15	ERROR#		
16	INIT#		
17	SELIN#		
18	GND		
19	GND		
20	GND		
21	GND		
22	GND		
23	GND		
24	GND		
25	GND		

LPC Firmware Hubs



The XTX Evaluation Baseboard offers the possibility to boot the XTX CPU module with a BIOS that is located on the XTX Evaluation Baseboard. This can be very useful when a customized BIOS must be evaluated.

The Evaluation Baseboard includes two 32-lead PLCC sockets for two LPC firmware hubs (FWH1 in socket S1 and FWH2 in socket S2). With the DIP switch M3, the user can configure which hub the XTX module should boot from.

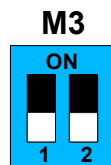

DIP Switch M3		Configuration
1 OFF	2 OFF	XTX Module boots from onboard FWH
1 ON	2 OFF	XTX Module boots from FWH1
1 OFF	2 ON	XTX Module boots from FWH2
1 ON	2 ON	Invalid configuration

3.3.6 Fan Connector and Power Configuration

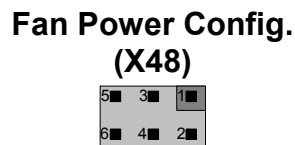
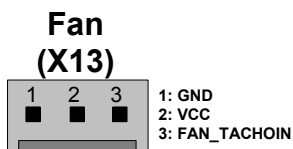

Jumper X48	Configuration
1 - 2	12 Volt Fan
3 - 4	N.C.
5 - 6	5 Volt Fan



Connector Type

X13: 3 pin 2.54mm grid fan connector,

X48: 2.54mm grid jumper.



Note

The FAN_TACHOIN signal, that is found on XTX modules and is connected to pin 3 on connector X13 of the conga-XEVAL, must receive two pulses per revolution in order to produce an accurate reading and therefore a two pulse per revolution fan is recommended.



3.4 Subsystems of XTX Connector X3

3.4.1 VGA Output, Serial Ports and Parallel Port / Floppy

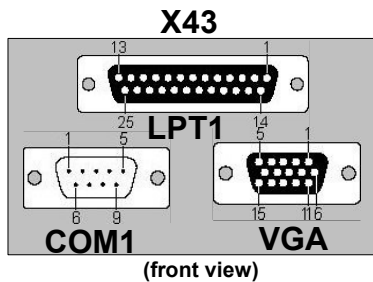

Pin	LPT1	VGA	COM1	COM2 (X32)
1	STROBE#	RED	DCD#	DCD#
2	PD0	GREEN	RXD	DSR#
3	PD1	BLUE	TXD	RXD
4	PD2	N.C.	DTR#	RTS#
5	PD3	GND	GND	TXD
6	PD4	GND	DSR	CTS#
7	PD5	GND	RTS#	DTR#
8	PD6	GND	CTS#	RI#
9	PD7	DDC Power	RI#	GND
10	ACK#	GND		+5V
11	BUSY	N.C.		
12	PE	DDC DAT		
13	SEL	HSYNC		
14	AUTOFD#	VSYNC		
15	ERROR#	DDC CLK		
16	INIT#			
17	SELIN#			
18	GND			
19	GND			
20	GND			
21	GND			
22	GND			
23	GND			
24	GND			
25	GND			



Connector Type

COM: 9 pin, D-SUB female. LPT: 24 pin, D-SUB male. VGA: 15 pin, high density D-SUB male. X32: 10 pin, 2 row 2.54mm grid female.

The TTL level of the two serial ports supported on the XTX modules is transformed on the XTX Evaluation Baseboard to RS232 level.

The Parallel Port (LPT1) on the XTX module is shared with the Floppy interface. The user can choose in the system BIOS if the Parallel Port or the Floppy interface should be made available.

congatec XTX Modules do not support the LPT/#FPY signal (XTX connector X3, pin 51). Jumper X30 therefore has no function.

The Floppy signals are available on the standard Floppy connector X36.



Floppy (X36)

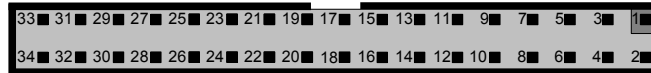

Pin	Signal	Pin	Signal	Pin	Signal	Pin	Signal
1	GND	2	DENSEL	19	GND	20	STEP#
3	GND	4	N.C.	21	GND	22	WDATA#
5	GND	6	N.C.	23	GND	24	WGATE#
7	GND	8	INDEX#	25	GND	26	TRK0#
9	GND	10	N.C.	27	GND	28	WP#
11	GND	12	DRV	29	GND	30	RDATA#
13	GND	14	N.C.	31	GND	32	HDSEL
15	GND	16	MOT	33	GND	34	DSKCHG#
17	GND	18	DIR#				



Connector Type

34 pin, 2 row 2.54mm grid female.

3.4.2 Flat Panel Interface

LCD (X31)

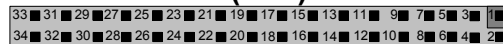

Pin	LVDS output	Digital (TTL) output	Pin	LVDS output	Digital (TTL) output
1	FPDDC_DAT		2	FPDDC_CLK	
3	N.C.		4	N.C.	
5	GND		6	LCDDO0	R0
7	LCDDO1	R1	8	DIGON	
9	LCDDO2	R2	10	LCDDO3	R3
11	BLON#		12	LCDDO5	R5
13	LCDDO4	R4	14	LTGIO0	VSYNC
15	LCDDO6	G0	16	LCDDO7	G1
17	BIASON	HSYNC	18	LCDDO9	G3
19	LCDDO8	G2	20	GND	
21	LCDDO10	G4	22	LCDDO11	G5
23	GND		24	LCDDO12	B0
25	LCDDO13	B1	26	GND	
27	LCDDO14	B2	28	LCDDO15	B3
29	GND		30	LCDDO17	B5
31	LCDDO16	B4	32	DETECT#	
33	LCDDO19	EN	34	LCDDO18	SHFTCLK



Connector Type

34 pin, 2 row 2mm grid female.



Flat Panel and Backlight Power Supply

The power supply for flat panels and their backlight inverter is available on connector X47.

LCD Power (X47)



Pin	Signal	Pin	Signal
1	SW_VDD (1.5A Fuse)	2	SW_BACK (0.75A Fuse)
3	+5V (1.5A Fuse)	4	+12V (0.75A Fuse)
5	DIGON	6	BL_ON
7	Potentiometer Low Terminal	8	Potentiometer Wiper Terminal
9	GND	10	GND



Connector Type

10 pin, 2 row 2.54 mm grid female.

LCD Power Config. (X45)

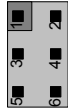

Jumper X45	Configuration
1 - 2	5V LCD Voltage
3 - 4	N.C.
5 - 6	3.3V LCD Voltage

Backlight Power Config. (X46)

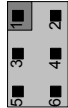

Jumper X46	Configuration
1 - 2	12V Backlight Voltage
3 - 4	N.C.
5 - 6	5V Backlight Voltage



Connector Type

X45 and X46: 2.54mm grid jumper



Note

See the following page for information about connection possibilities for the LCD Power X47 connector.



Flat Panel and Backlight Power Supply Connection Possibilities

The following diagram shows the typical connection for powering panel/backlight by either the SW_VDD/SW_BACK signals or by using DIGON/BL_ON for external power switches.

- Signals 1-8 correspond to signals 1-8 found on the X47 connector.
- X45 and X46 represent Jumpers X45 and X46 found on the XTX evaluation baseboard.
- The conga-EVAL baseboard is equipped with a Maxim MAX5434 device.

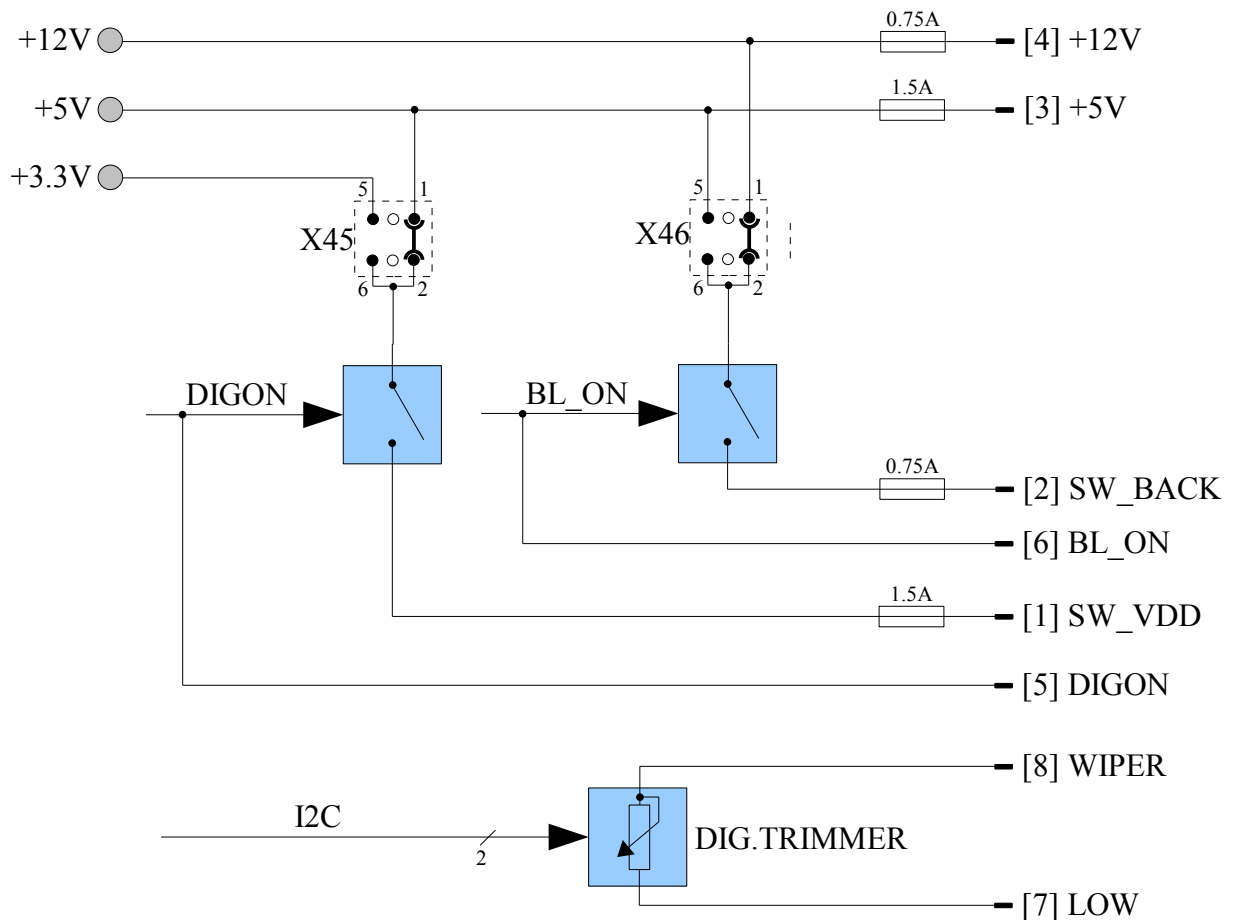

Flat Panel Configuration Data

The flat panel configuration data (EPI extended EDID™ 1.3 file) for most common displays is included in the XTX module's system BIOS. The customer also has the possibility to use a customized EPI extended EDID™ file that can be stored in a serial EEPROM located on the XTX Evaluation baseboard (DIL 8 socket U19).

Supported EEPROMs: 24C02, 24C04 and 24C16 at address A0h.



3.4.3 TV Interface

TV-Out (X44)

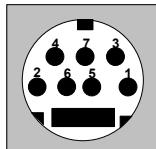

(front view)

Pin	Signal	Pin	Signal
1	GND	2	GND
3	Y	4	C
5	GND	6	N.C.
7	COMP		



Connector Type

7 pin MINI-DIN male.

The X44 connector is compatible and can be used with the standard 4pin SVIDEO plug. Composite video is not available in this configuration.

When S-Video and Composite Video signals are required, the adapter cable '7-pin to S-VIDEO and RCA' (7-PIN-SV+RCA) from www.svideo.com can be used to make these signals available on standard S-Video and Composite Video connectors.

3.4.4 Serial Infrared Interface (IrDA)

IrDA (X35)



Pin	Signal	Pin	Signal
1	+5V	2	N.C.
3	IRRX	4	GND
5	IRTX		



Connector Type

5 pin, 1 row 2.54 mm grid female.

3.4.5 PS/2 Mouse and Keyboard

X42

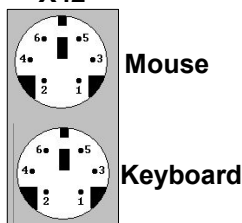

Pin	Mouse	Keyboard
1	MSDAT	KBDAT
2	N.C.	N.C.
3	GND	GND
4	+5V	+5V
5	MSCLK	KBCLK
6	N.C.	N.C.



Connector Type

Mouse and Keyboard: 6 pin MINI-DIN female



3.5 Subsystems of XTX Connector X4

3.5.1 IDE

IDE2 (X16)

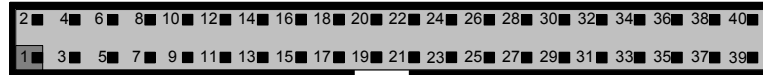

IDE1 (X19)



Pin	Signal	Pin	Signal	Pin	Signal	Pin	Signal
1	HDRST#	2	GND	21	IDE_DRQ	22	GND
3	IDE_D7	4	IDE_D8	23	IDE_IOW#	24	GND
5	IDE_D6	6	IDE_D9	25	IDE_IOR#	26	GND
7	IDE_D5	8	IDE_D10	27	IDE_RDY	28	CSEL
9	IDE_D4	10	IDE_D11	29	IDE_ACK	30	GND
11	IDE_D3	12	IDE_D12	31	IDE_INTRQ	32	N.C.
13	IDE_D2	14	IDE_D13	33	IDE_A1	34	CBLID_P# (prim. IDE port) PDIAG_S (sec. IDE port)
15	IDE_D1	16	IDE_D14	35	IDE_A0	36	IDE_A2
17	IDE_D0	18	IDE_D15	37	IDE_CS1	38	IDE_CS3
19	GND	20	N.C.	39	ACTIVITY	40	GND



Connector Type

40 pin, 2 row 2.54mm grid female.

3.5.2 Ethernet

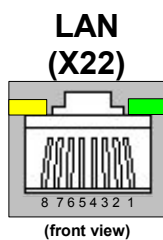

Pin	Signal	Pin	Signal
1	TX+	2	TX-
3	RX+	4	Shield GND
5	Shield GND	6	RX-
7	Shield GND	8	Shield GND

LED	Description
Yellow	Link
Green	Activity
D28	Speed Indicator (10 / 100 MBit)



Connector Type

8 pin RJ45 plug



Note

Connector X23 is intended for internal use.



3.5.3 Feature Connector

Feature (X24)

2	4	6	8	10	12	14	16	18	20	22	24	26	28	30	32	34	36	38	40
1	3	5	7	9	11	13	15	17	19	21	23	25	27	29	31	33	35	37	39

Pin	Signal	Pin	Signal	Pin	Signal	Pin	Signal
1	+5V (750 mA fuse)	2	5V_SB (750 mA fuse)	21	GND	22	GND
3	+5V (750 mA fuse)	4	Hard Disk Activity	23	SUS_STAT#	24	EXTSMI#
5	I2DAT	6	SMBCLK	25	GND	26	GND
7	I2CLK	8	SMBDATA	27	WDTRIG	28	GPE2#
9	Internal use	10	SERIRQ	29	GND	30	GND
11	Internal use	12	Reserved	31	BATTLOW#	32	GPE1#
13	Reserved	14	GPCS#	33	GND	34	GND
15	Reserved	16	IL_SATA#	35	KBINH#	36	RSMRST#
17	GND	18	GND	37	GND	38	GND
19	Reserved	20	SMBALRT#	39	PWBTN#	40	PWGIN



Connector Type

40 pin, 2 row 2.54mm grid female.



Note

Connector X25 is intended for internal use.

3.5.4 I²C Bus

The I²C signals are available on the feature connector (X24) described in the previous section.

The XTX Evaluation Baseboard includes a socket for an I²C EEPROM (U17) that can be used for test purposes during the system development.

The 8 pin DIP socket on the XTX Evaluation Baseboard can be used with different 2-wire serial EEPROMS (for example 24C04 / 08 / 16 ...) and can be accessed easily by using the I²C control commands implemented in the congatec CGOS API driver. Please refer to the XTX module's User's Guide and CGOS manual for details.



4 Additional Features

4.1 Reset

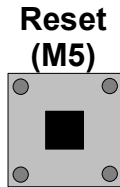

The XTX module and all connected components will perform a hard reset when this button is pressed. The Reset button is connected to the XTX modules PWGIN signal.

4.2 PC Speaker (Beeper)

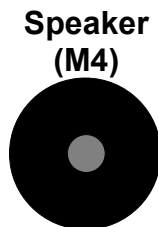

The board-mounted speaker provides audible error code (beep code) information during POST. The speaker M4 is connected to the XTX modules SPEAKER signal.

4.3 Debug Display

During the POST (Power On Self Test), the BIOS generates diagnostic progress codes (POST-codes) to different I/O ports (usually port 80h). If the POST fails, execution stops and the last POST code generated is left at the respective port. This code is useful for determining the point where an error occurred.

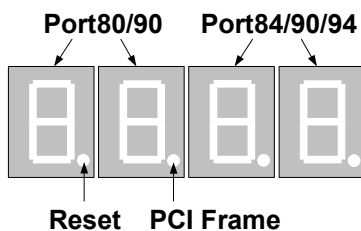

The XTX Evaluation Baseboard decodes these ports and displays their contents on 4 seven-segment displays (D35 to D38). The dots in the first two displays show the state of the Reset and the PCI Frame signals.

A list of the POST codes and associated POST test and initialization routines for the BIOS used on congatec XTX modules is available on: <http://www.congatec.com>.



Debug Config. (X37)

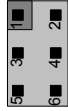

Jumper X37	Configuration
1 - 2	Port 80h and port 84h output
3 - 4	Port 80h and port 90h output
5 - 6	Port 90h and port 94h output



Connector Type

2.54mm grid jumper.



Note

Connector X38 is intended for internal use.

4.4 Ground Test Points

Test Point (TP)



The XTX Evaluation Baseboard provides 4 test points that are connected to Ground Potential (TP1 to TP4). These test points make it easier to connect oscilloscope probes and/or multimeter lines to Ground when performing measurements on the XTX module.

5 Mechanical Drawing conga-XEVAL

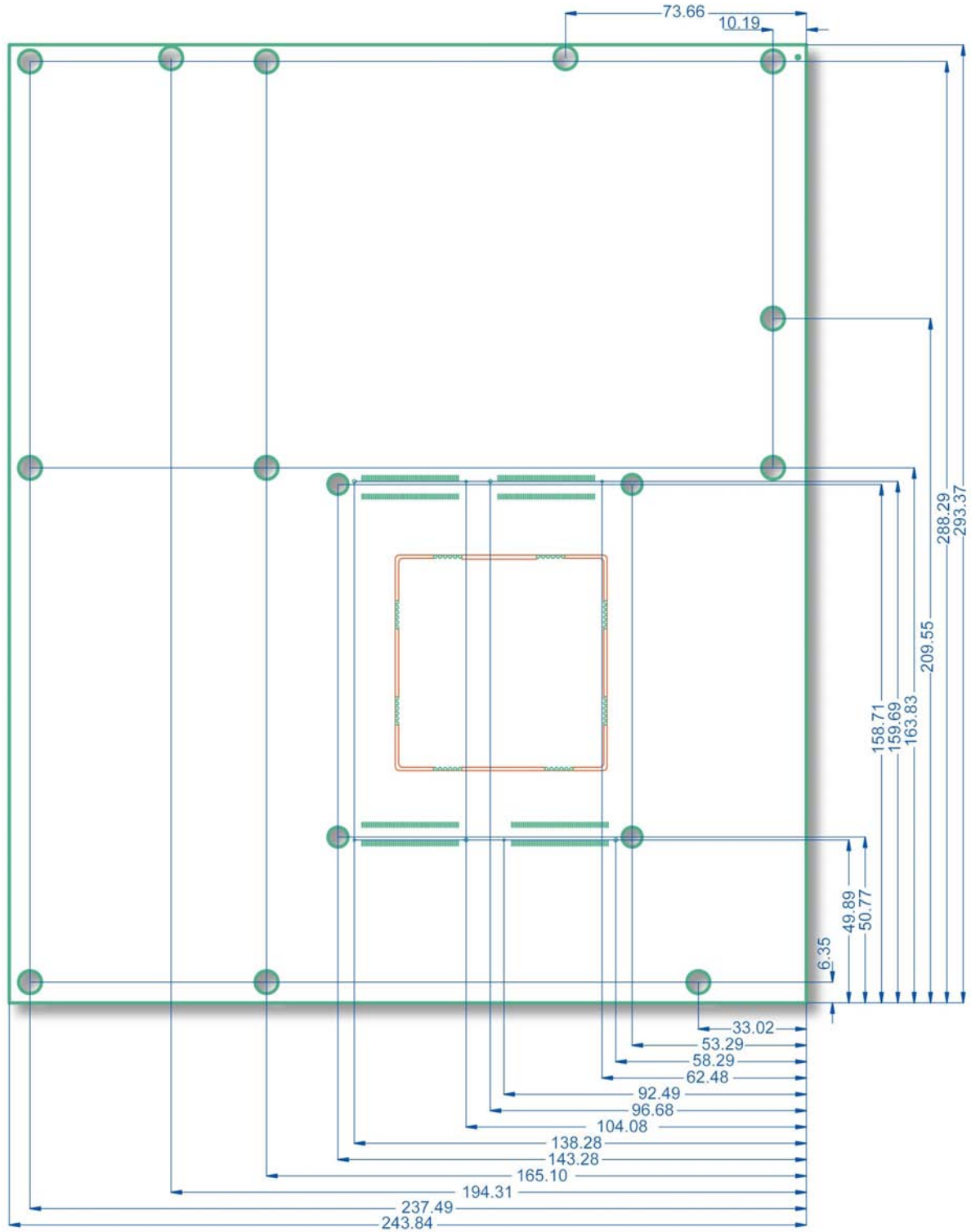

6 Industry Specifications

The list below provides links to industry specifications that apply to congatec AG modules.

Specification	Link
XTX Specification 1.0	http://www.xtx-standard.org/fileadmin/XTX-Spec10.pdf
ETX Specification 2.7	http://www.jumptec.de/product/data/etx/pdf/ETXSpecV2.7.pdf
Audio Codec '97 Component Specification, Version 2.3 (AC '97)	http://www.intel.com/design/chipsets/audio/
Low Pin Count Interface Specification, Revision 1.0 (LPC)	http://developer.intel.com/design/chipsets/industry/lpc.htm
Universal Serial Bus (USB) Specification, Revision 2.0	http://www.usb.org/home
PCI Specification, Revision 2.2	http://www.pcisig.com/specifications
PCI Express Base Specification, Revision 1.0a	http://www.pcisig.com/specifications
Serial ATA Specification, Revision 1.0a	http://www.serialata.org

Mouser Electronics

Authorized Distributor

Click to View Pricing, Inventory, Delivery & Lifecycle Information:

[congatec:](#)

[conga-Xeval](#)