

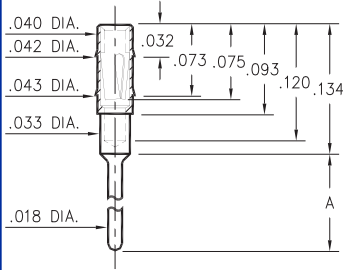

**PIN RECEPTACLES**  
 for .015" - .020" diameter pins (#11 contact)  
 and .015" - .022" diameter pins (#05 & #21 contacts)  
 (see specific contact range on page 217)



**0489**



Basic Part Number	Length A
0489-0	.102
0489-1	.199
0489-2	.299

**0489-X-15-XX-11-XX-04-0**  
 Press-fit in .041 mounting hole.

**0463**

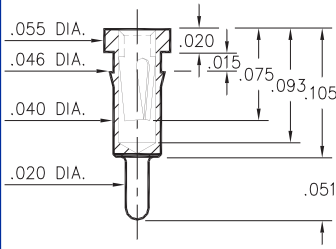

**0463-0-15-XX-21-XX-04-0**  
 Press-fit in .043 mounting hole.  
 shell is Phos. Br. Alloy 544 (B2)

**0466**

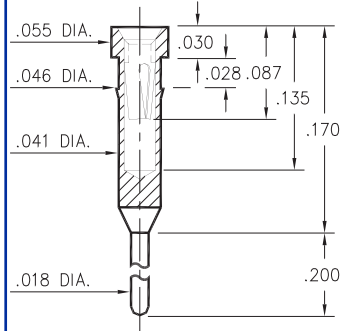

**0466-0-15-XX-21-XX-04-0**  
 Press-fit in .043 mounting hole.  
 shell is Phos. Br. Alloy 544 (B2)

**7491**

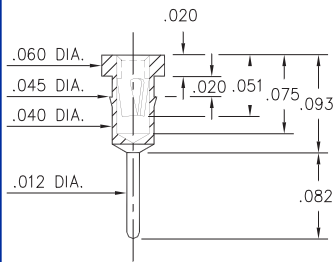

**7491-0-15-XX-X1-XX-04-0**  
 Press-fit in .042 mounting hole

**0462**

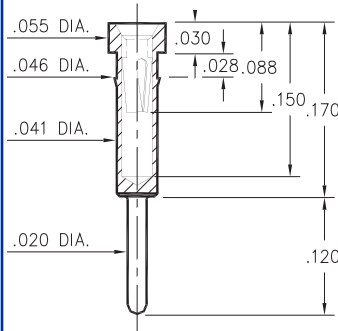

**0462-0-15-XX-X1-XX-04-0**  
 Press-fit in .043 mounting hole

**0560**

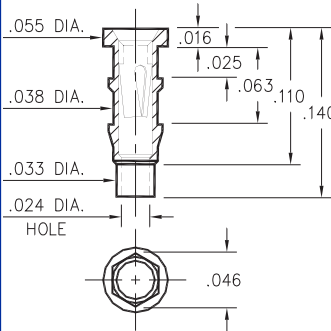

**0560-0-15-XX-11-XX-10-0**  
 Hex press-fit in .043 plated thru hole

**5552**

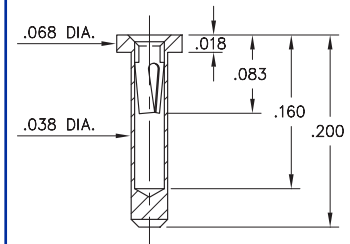

**5552-0-15-XX-05-XX-10-0**  
 Solder mount in .040 min. mounting hole

**4890**

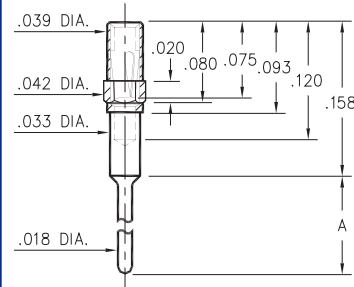

Basic Part Number	Length A
4890-0	.102
4890-1	.199
4890-2	.299

**4890-X-15-XX-11-XX-04-0**  
 Octagonal press-fit in .041 mounting hole.

**SPECIFICATIONS**

**SHELL MATERIAL:**  
 Brass Alloy 360, 1/2 Hard

**CONTACT MATERIAL:**  
 Beryllium Copper Alloy 172, HT

**DIMENSION IN INCHES**  
**TOLERANCES ON:**  
 LENGTHS: ±.005  
 DIAMETERS: ±.002  
 ANGLES: ± 2°

**ORDER CODE: XXXX - X - 1X - XX - XX - XX - XX - 0**

**BASIC PART #**

**SPECIFY SHELL FINISH:**  
 01 200µ" TIN/LEAD OVER NICKEL  
 ◇ 80 200µ" TIN OVER NICKEL (RoHS)  
 ◇ 15 10µ" GOLD OVER NICKEL (RoHS)

**SPECIFY CONTACT FINISH:**  
 02 100µ" TIN/LEAD OVER NICKEL  
 ◇ 84 100µ" TIN OVER NICKEL (RoHS)  
 ◇ 27 30µ" GOLD OVER NICKEL (RoHS)



**SELECT CONTACT**

#05, #11 or #21 CONTACT (DATA ON PAGE 217)