

32 Mbyte, 64 Mbyte, 128 Mbyte, 256 Mbyte and 512 Mbyte 3.3 V / 5 V supply CompactFlash™ card

Features

- Custom-designed, highly-integrated memory controller
 - Fully compliant with CompactFlash™ specification 2.0
 - Fully compatible with PCMCIA specification
 - PC card ATA interface supported
 - True IDE mode compatible
- Small form factor
 - 36.4 mm x 42.8 mm x 3.3 mm
- Low-power CMOS technology
- 3.3 V / 5.0 V power supply
- Power saving mode (with automatic wake-up)
- High reliability
 - MTBF > 3,000,000 hours
 - Data reliability: < 1 non-recoverable error per 10¹⁴ bits read
 - Endurance: > 2,000,000 Erase/Program cycles
 - Number of card insertions/removals: > 10,000

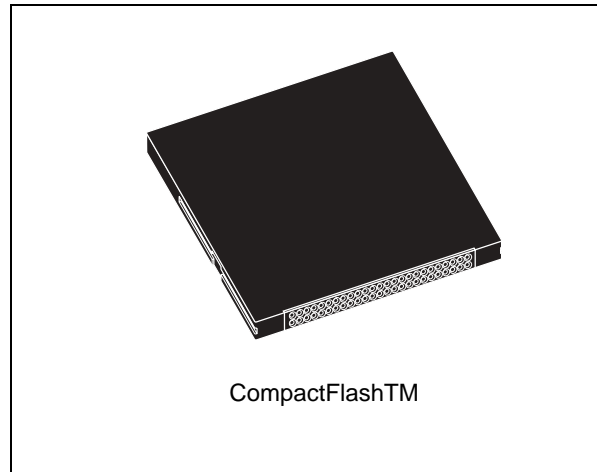

- High performance
 - Up to 16.6 Mbit/s transfer rate
 - Sustained write performance (host to card: 7.2 Mbit/s)
- Operating system support
 - Standard software drivers operation
- Available densities (formatted)
 - 32 Mbytes to 512 Mbytes
- Hot swappable

Table 1. Device summary

Reference	Part number	Package form factor	Operating voltage range
SMCxxxAF	SMC032AF	CF type I	3.3 V+-10%, 5 V+-10%
	SMC064AF ⁽¹⁾		
	SMC128AF ⁽¹⁾		
	SMC256AF ⁽¹⁾		
	SMC512AF ⁽¹⁾		

1. Obsolete part number.

Contents

- 1 Description 10**
- 2 Capacity specification 12**
- 3 Card physical description 13**
- 4 Electrical interface 14**
 - 4.1 Electrical description 14
 - 4.2 Electrical specification 20
 - 4.3 Current measurement 20
- 5 Command interface 22**
- 6 Card configuration 30**
 - 6.1 Configuration Option register (base + 00h in attribute memory) 31
 - 6.1.1 LevIREQ 31
 - 6.1.2 Conf5 - Conf0 (configuration index) 31
 - 6.2 Card Configuration and Status register (base + 02h in attribute memory) 32
 - 6.2.1 Changed 32
 - 6.2.2 SigChg 32
 - 6.2.3 IOis8 32
 - 6.2.4 PwrDwn 32
 - 6.2.5 Int 32
 - 6.3 Pin Replacement register (base + 04h in attribute memory) 33
 - 6.3.1 CReady 33
 - 6.3.2 CWProt 33
 - 6.3.3 RReady 33
 - 6.3.4 WProt 33
 - 6.3.5 MReady 33
 - 6.3.6 MWProt 33
 - 6.4 Socket and Copy register (base + 06h in attribute memory) 34
 - 6.4.1 Drive # 34
 - 6.4.2 X 34
 - 6.5 Attribute memory function 35

6.6	I/O transfer function	36
6.7	Common memory transfer function	37
6.8	True IDE mode I/O function	38
7	Software interface	39
7.1	CF-ATA Drive register set definition and protocol	39
7.2	Memory mapped addressing (conf = 0)	39
7.3	Contiguous I/O mapped addressing (conf = 1)	41
7.4	I/O primary and secondary address configurations (conf = 2,3)	42
7.5	True IDE mode addressing	43
8	CF-ATA registers	44
8.1	Data register (address 1F0h [170h]; offset 0, 8, 9)	44
8.2	Error register (address 1F1h [171h]; offset 1, 0Dh read only)	44
8.2.1	Bit 7 (BBK)	44
8.2.2	Bit 6 (UNC)	44
8.2.3	Bit 5	44
8.2.4	Bit 4 (IDNF)	45
8.2.5	Bit 3	45
8.2.6	Bit 2 (abort)	45
8.2.7	Bit 1	45
8.2.8	Bit 0 (AMNF)	45
8.3	Feature register (address 1F1h [171h]; offset 1, 0Dh write only)	45
8.4	Sector Count register (address 1F2h [172h]; offset 2)	45
8.5	Sector Number (LBA 7-0) register (address 1F3h [173h]; offset 3)	45
8.6	Cylinder Low (LBA 15-8) register (address 1F4h [174h]; offset 4)	46
8.7	Cylinder High (LBA 23-16) register (address 1F5h [175h]; offset 5)	46
8.8	Drive/Head (LBA 27-24) register (address 1F6h [176h]; offset 6)	46
8.8.1	Bit 7	46
8.8.2	Bit 6 (LBA)	46
8.8.3	Bit 5	46
8.8.4	Bit 4 (DRV)	46
8.8.5	Bit 3 (HS3)	46
8.8.6	Bit 2 (HS2)	47
8.8.7	Bit 1 (HS1)	47

- 8.8.8 Bit 0 (HS0) 47
- 8.9 Status & alternate status registers (address 1F7h [177h] & 3F6h [376h]; offsets 7 & Eh) 48
 - 8.9.1 Bit 7 (BUSY) 48
 - 8.9.2 Bit 6 (RDY) 48
 - 8.9.3 Bit 5 (DWF) 48
 - 8.9.4 Bit 4 (DSC) 48
 - 8.9.5 Bit 3 (DRQ) 48
 - 8.9.6 Bit 2 (CORR) 48
 - 8.9.7 Bit 1 (IDX) 48
 - 8.9.8 Bit 0 (ERR) 48
- 8.10 Device control register (address 3F6h [376h]; offset Eh) 49
 - 8.10.1 Bit 7 to 3 49
 - 8.10.2 Bit 2 (SW Rst) 49
 - 8.10.3 Bit 1 (-IEn) 49
 - 8.10.4 Bit 0 49
- 8.11 Card (drive) address register (address 3f7h [377h]; offset Fh) 50
 - 8.11.1 Bit 7 50
 - 8.11.2 Bit 6 (-WTG) 50
 - 8.11.3 Bit 5 (-HS3) 50
 - 8.11.4 Bit 4 (-HS2) 50
 - 8.11.5 Bit 3 (-HS1) 50
 - 8.11.6 Bit 2 (-HS0) 50
 - 8.11.7 Bit 1 (-nDS1) 50
 - 8.11.8 Bit 0 (-nDS0) 50
- 9 CF-ATA command description 51**
 - 9.1 Check Power mode command (98h or E5h) 52
 - 9.2 Execute Drive Diagnostic command (90h) 53
 - 9.3 Erase Sector(s) command (C0h) 54
 - 9.4 Identify Drive command (ECh) 54
 - 9.4.1 Word 0: general configuration 54
 - 9.4.2 Word 1: default number of cylinders 54
 - 9.4.3 Word 3: default number of heads 54
 - 9.4.4 Word 6: default number of sectors per track 54
 - 9.4.5 Word 7-8: number of sectors per card 54
 - 9.4.6 Word 10-19: memory card serial number 55

9.4.7	Word 23-26: firmware revision	55
9.4.8	Word 27-46: model number	55
9.4.9	Word 47: read/write multiple sector count	55
9.4.10	Word 49: capabilities	55
9.4.11	Word 51: PIO data transfer cycle timing mode	55
9.4.12	Word 53: translation parameter valid	55
9.4.13	Word 54-56: current number of cylinders, heads, sectors/track	55
9.4.14	Word 57-58: current capacity	55
9.4.15	Word 59: multiple sector setting	56
9.4.16	Word 60-61: total sectors addressable in LBA mode	56
9.4.17	Word 64: advanced PIO transfer modes supported	56
9.4.18	Word 67: minimum PIO transfer cycle time without flow control	56
9.4.19	Word 68: minimum PIO transfer cycle time with IORDY	56
9.5	Idle command (97h or E3h)	58
9.6	Idle Immediate command (95h or E1h)	59
9.7	Initialize Drive Parameters command (91h)	59
9.8	NOP command (00h)	60
9.9	Read Buffer command (E4h)	60
9.10	Read Multiple command (C4h)	61
9.11	Read Sector(s) command (20h or 21h)	62
9.12	Read Verify Sector(s) command (40h or 41h)	62
9.13	Recalibrate command (1Xh)	63
9.14	Request Sense command (03h)	63
9.15	Seek command (7Xh)	65
9.16	Set Features command (EFh)	65
9.17	Set Multiple mode command (C6h)	67
9.18	Set Sleep mode command (99h or E6h)	67
9.19	Standby command (96h or E2)	68
9.20	Standby Immediate command (94h or E0h)	68
9.21	Translate Sector command (87h)	69
9.22	Wear Level command (F5h)	70
9.23	Write Buffer command (E8h)	70
9.24	Write Multiple command (C5h)	71
9.25	Write Multiple without Erase command (CDh)	72

9.26	Write Sector(s) command (30h or 31h)	72
9.27	Write Sector(s) without Erase command (38h)	73
9.28	Write Verify command (3Ch)	73
10	CIS information (typical)	74
11	Package mechanical	79
12	Ordering information	80
13	Revision history	81

List of tables

Table 1.	Device summary	1
Table 2.	System performance.	11
Table 3.	Current consumption	11
Table 4.	Environmental specifications	11
Table 5.	Physical dimensions	11
Table 6.	CF capacity specification	12
Table 7.	System reliability and maintenance	12
Table 8.	Pin assignment and pin type.	14
Table 9.	Signal description	16
Table 10.	Absolute maximum conditions	20
Table 11.	Input power	20
Table 12.	Input leakage current	20
Table 13.	Input characteristics	21
Table 14.	Output drive type	21
Table 15.	Output drive characteristics	21
Table 16.	Attribute memory Read timing	22
Table 17.	Configuration register (attribute memory) Write timing	23
Table 18.	Common memory Read timing	24
Table 19.	Common memory Write timing	25
Table 20.	I/O Read timing	26
Table 21.	I/O Write timing	27
Table 22.	True IDE mode I/O Read/Write timing diagram	29
Table 23.	CompactFlash memory card registers and memory space decoding.	30
Table 24.	CompactFlash memory card configuration registers decoding.	31
Table 25.	Configuration Option register (default value: 00h)	31
Table 26.	CompactFlash memory card configurations	31
Table 27.	Card Configuration and Status register (default value: 00h).	32
Table 28.	Pin Replacement register (default value: 0Ch).	33
Table 29.	Pin Replacement Changed bit/Mask bit values	33
Table 30.	Socket and Copy register (default value: 00h)	34
Table 31.	Attribute memory function.	35
Table 32.	I/O function	36
Table 33.	Common memory function	37
Table 34.	True IDE mode I/O function	38
Table 35.	I/O configurations	39
Table 36.	Memory mapped decoding	40
Table 37.	Contiguous I/O decoding	41
Table 38.	Primary and secondary I/O decoding	42
Table 39.	True IDE mode I/O decoding	43
Table 40.	Data register access	44
Table 41.	Error register	45
Table 42.	Drive/Head register	47
Table 43.	Status & alternate status register	49
Table 44.	Device control register	49
Table 45.	Card (drive) address register	50
Table 46.	CF-ATA command set	51
Table 47.	Check Power mode	52
Table 48.	Execute Drive Diagnostic	53

Table 49.	Diagnostic codes	53
Table 50.	Erase Sector(s)	54
Table 51.	Identify drive	56
Table 52.	Identify drive information	57
Table 53.	Idle	58
Table 54.	Idle Immediate	59
Table 55.	Initialize Drive Parameters	59
Table 56.	NOP	60
Table 57.	Read Buffer	60
Table 58.	Read Multiple	61
Table 59.	Read Sector(s)	62
Table 60.	Read Verify Sector(s)	63
Table 61.	Recalibrate	63
Table 62.	Request Sense	64
Table 63.	Extended Error codes	64
Table 64.	Seek	65
Table 65.	Set Features	66
Table 66.	Features supported	66
Table 67.	Transfer mode values	66
Table 68.	Set Multiple mode	67
Table 69.	Set Sleep mode	67
Table 70.	Standby	68
Table 71.	Standby Immediate	68
Table 72.	Translate Sector	69
Table 73.	Translate Sector information	69
Table 74.	Wear Level	70
Table 75.	Write Buffer	70
Table 76.	Write Multiple	71
Table 77.	Write Multiple without Erase	72
Table 78.	Write Sector(s)	72
Table 79.	Write Sector(s) without Erase	73
Table 80.	Write Verify	73
Table 81.	Ordering information scheme	80
Table 82.	Document revision history	81

List of figures

Figure 1. CompactFlash memory card block diagram 13
Figure 2. Attribute memory Read timing diagram 22
Figure 3. Configuration register (attribute memory) Write timing diagram 23
Figure 4. Common memory Read timing diagram 24
Figure 5. Common memory Write timing diagram 25
Figure 6. I/O Read timing diagram 26
Figure 7. I/O Write timing diagram 27
Figure 8. True IDE mode I/O timing diagram 28
Figure 9. Type I CompactFlash memory card dimensions. 79

1 Description

The CompactFlash is a small form factor non-volatile memory card which provides high capacity data storage. Its aim is to capture, retain and transport data, audio and images, facilitating the transfer of all types of digital information between a large variety of digital systems.

The card operates in three basic modes,

- PCMCIA I/O mode
- PCMCIA memory mode
- True IDE mode

It conforms to the PC card specification when operating in the PCMCIA I/O mode and PCMCIA memory mode (Personal Computer Memory Card International Association standard, JEIDA in Japan) and to the ATA specification when operating in True IDE mode. CompactFlash cards can be used with passive adapters in a PC-card type II or type III socket.

The card has an internal intelligent controller which manages interface protocols, data storage and retrieval as well as error correcting code (ECC), defect handling, diagnostics and clock control. Once the card has been configured by the host, it behaves as a standard ATA (IDE) disk drive.

The card has a super cap on V_{CC} and a powerful power-loss management feature to prevent data corruption after power-down.

The specification has been realized and approved by the CompactFlash association (CFA). This non-proprietary specification enables users to develop CF products that function correctly and are compatible with future CF design.

The system highlights are shown in [Table 2](#), [Table 3](#), [Table 4](#), [Table 5](#), [Table 6](#) and [Table 7](#).

Related documentation

- PCMCIA PC card standard, 1995
- PCMCIA PC card ATA specification, 1995
- AT attachment interface document, American National Standards Institute, X3.221-1994
- CF+ and CompactFlash specification revision 2.0.

Table 2. System performance

System performance		Max	Unit
Sleep to write		2.2	ms
Sleep to read		2.4	ms
Power-up to ready		80	ms
Data transfer rate (burst)		16.6 (113X) ⁽¹⁾	Mbit/s
Sustained Read		12.2 (83X) ⁽¹⁾	Mbit/s
Sustained Write		7.2 (49X) ⁽¹⁾	Mbit/s
Command to DRQ	Read	180	μs
	Write	40	

1. 113X, 83X and 49X, speed grade markings where 1X = 150 Kbytes/s. All values refer to the 256-Mbyte CompactFlash card in PIO mode 4, cycle time 120 ns.

Table 3. Current consumption⁽¹⁾

Current consumption (typ)	3.3 V	5 V	Unit
Read	57	60	mA
Write	70	71	mA
Standby	0.4	1	mA
Sleep mode	0.4	1	mA

1. All values are typical at 25 °C and nominal supply voltage and refer to 256-Mbyte CompactFlash card.

Table 4. Environmental specifications

Environmental specifications	Operating	Non-operating
Temperature	−40 to 85 °C	−50 to 100 °C
Humidity (non-condensing)	N/A	85% RH, at 85 °C
Salt water spray	N/A	3% NaCl at 35 °C ⁽¹⁾
Vibration (peak -to-peak)	N/A	30 Gmax
Shock	N/A	3,000 Gmax

1. MIL STD METHOD 1009.

Table 5. Physical dimensions

Physical dimensions	Unit
Width	42.8 mm
Height	36.4 mm
Thickness	3.3 mm
Weight (typ)	10 g

2 Capacity specification

[Table 6](#) shows the specific capacity for the various CF models and the default number of heads, sector/tracks and cylinders.

Table 6. CF capacity specification

Model No	Capacity	Default_cylinders	Default_heads	Default_sectors_ track	Sectors_card	Total addressable capacity (byte)
SMC032	32 Mbyte	492 (0x1EC)	8 (0x08)	16 (0x10)	62976	32243712
SMC064	64 Mbyte	496 (0x1F0)	8 (0x08)	32 (0x20)	126976	65011712
SMC128	128 Mbyte	498 (0x1F2)	16 (0x10)	32 (0x20)	254976	130547712
SMC256	256 Mbyte	998 (0x3E6)	16 (0x10)	32 (0x20)	510976	261619712
SMC512	512 Mbyte	1014 (0x3F6)	16 (0x10)	63 (0x3F)	1022112	523321344

Table 7. System reliability and maintenance

MTBF (at 25 °C)	> 3,000,000 hours
Insertions/removals	> 10,000
Preventive maintenance	None
Data reliability	< 1 non-recoverable error per 10^{14} bits Read
Endurance	0 + 70 C > 2,000,000 Erase/Program cycles ⁽¹⁾
	-40 + 85 C > 600,000 Erase/Program cycles ⁽¹⁾

1. Dependent on final system qualification data.

3 Card physical description

The CompactFlash memory card contains a single chip controller and Flash memory module(s). The controller interfaces with a host system allowing data to be written to and read from the Flash memory module(s). *Figure 1* shows the block diagram of the CompactFlash memory card.

The card is offered in a type I package with a 50-pin connector consisting of two rows of 25 female contacts on 50 mil (1.27 mm) centers. *Figure 9* shows type I card dimensions.

Figure 1. CompactFlash memory card block diagram

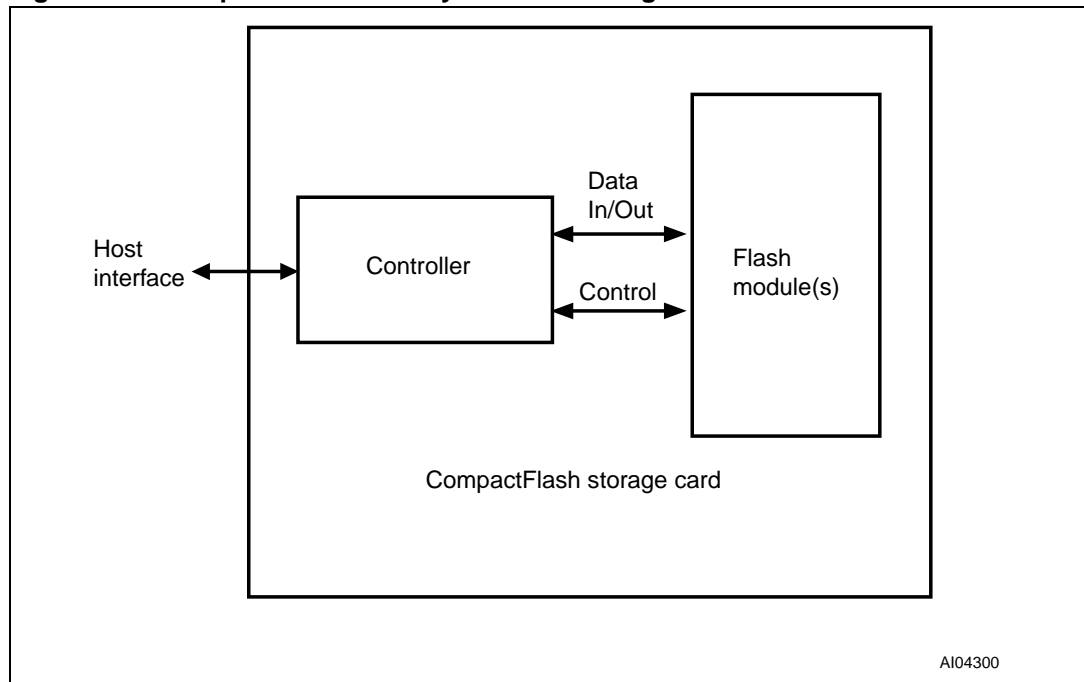

4 Electrical interface

4.1 Electrical description

The CompactFlash memory card operates in three basic modes:

- PC card ATA using I/O mode,
- PC card ATA using memory mode,
- True IDE mode, which is compatible with most disk drives.

The signal/pin assignments are listed in [Table 8](#) where Low active signals have a '-' prefix. Pin types are Input, Output or Input/Output.

The configuration of the card is controlled using the standard PCMCIA Configuration registers starting at address 200h in the attribute memory space of the memory card. For True IDE mode, pin 9 is grounded.

[Table 9](#) describes the I/O signals. Inputs are signals sourced from the host while outputs are signals sourced from the card. The signals are described for each of the three operating modes.

All outputs from the card are totem pole except the data bus signals that are bi-directional tri-state. Refer to [Section 4.2: Electrical specification](#) for definitions of Input and Output type.

Table 8. Pin assignment and pin type

Pin num	PC card memory mode			PC card I/O mode			True IDE mode		
	Signal name	Pin type	In, Out type	Signal name	Pin type	In, Out type	Signal name	Pin type	In, Out type
1	GND		Ground	GND		Ground	GND		Ground
2	D03	I/O	I1Z,OZ3	D03	I/O	I1Z,OZ3	D03	I/O	I1Z,OZ3
3	D04	I/O	I1Z,OZ3	D04	I/O	I1Z,OZ3	D04	I/O	I1Z,OZ3
4	D05	I/O	I1Z,OZ3	D05	I/O	I1Z,OZ3	D05	I/O	I1Z,OZ3
5	D06	I/O	I1Z,OZ3	D06	I/O	I1Z,OZ3	D06	I/O	I1Z,OZ3
6	D07	I/O	I1Z,OZ3	D07	I/O	I1Z,OZ3	D07	I/O	I1Z,OZ3
7	-CE1	I	I3U	-CE1	I	I3U	-CS0	I	I3Z
8	A10	I	I1Z	A10	I	I1Z	A10 ⁽¹⁾	I	I1Z
9	-OE	I	I3U	-OE	I	I3U	-ATASEL	I	I3U
10	A09	I	I1Z	A09	I	I1Z	A09 ⁽¹⁾	I	I1Z
11	A08	I	I1Z	A08	I	I1Z	A08 ⁽¹⁾	I	I1Z
12	A07	I	I1Z	A07	I	I1Z	A07 ⁽¹⁾	I	I1Z
13	V _{CC}		Power	V _{CC}		Power	V _{CC}		Power
14	A06	I	I1Z	A06	I	I1Z	A06 ⁽¹⁾	I	I1Z
15	A05	I	I1Z	A05	I	I1Z	A05 ⁽¹⁾	I	I1Z
16	A04	I	I1Z	A04	I	I1Z	A04 ⁽¹⁾	I	I1Z
17	A03	I	I1Z	A03	I	I1Z	A03 ⁽¹⁾	I	I1Z
18	A02	I	I1Z	A02	I	I1Z	A02	I	I1Z
19	A01	I	I1Z	A01	I	I1Z	A01	I	I1Z

Table 8. Pin assignment and pin type (continued)

Pin num	PC card memory mode			PC card I/O mode			True IDE mode		
	Signal name	Pin type	In, Out type	Signal name	Pin type	In, Out type	Signal name	Pin type	In, Out type
20	A00	I	I1Z	A00	I	I1Z	A00	I	I1Z
21	D00	I/O	I1Z,OZ3	D00	I/O	I1Z,OZ3	D00	I/O	I1Z,OZ3
22	D01	I/O	I1Z,OZ3	D01	I/O	I1Z,OZ3	D01	I/O	I1Z,OZ3
23	D02	I/O	I1Z,OZ3	D02	I/O	I1Z,OZ3	D02	I/O	I1Z,OZ3
24	WP	O	OT3	-IOIS16	O	OT3	-IOIS16	O	ON3
25	-CD2	O	Ground	-CD2	O	Ground	-CD2	O	Ground
26	-CD1	O	Ground	-CD1	O	Ground	-CD1	O	Ground
27	D11 ⁽²⁾	I/O	I1Z,OZ3	D11 ⁽²⁾	I/O	I1Z,OZ3	D11 ⁽²⁾	I/O	I1Z,OZ3
28	D12 ⁽²⁾	I/O	I1Z,OZ3	D12 ⁽²⁾	I/O	I1Z,OZ3	D12 ⁽²⁾	I/O	I1Z,OZ3
29	D13 ⁽²⁾	I/O	I1Z,OZ3	D13 ⁽²⁾	I/O	I1Z,OZ3	D13 ⁽²⁾	I/O	I1Z,OZ3
30	D14 ⁽²⁾	I/O	I1Z,OZ3	D14 ⁽²⁾	I/O	I1Z,OZ3	D14 ⁽²⁾	I/O	I1Z,OZ3
31	D15 ⁽²⁾	I/O	I1Z,OZ3	D15 ⁽²⁾	I/O	I1Z,OZ3	D15 ⁽²⁾	I/O	I1Z,OZ3
32	-CE2 ⁽²⁾	I	I3U	-CE2 ⁽²⁾	I	I3U	-CS1 ⁽²⁾	I	I3Z
33	-VS1	O	Ground	-VS1	O	Ground	-VS1	O	Ground
34	-IORD	I	I3U	-IORD	I	I3U	-IORD	I	I3Z
35	-IOWR	I	I3U	-IOWR	I	I3U	-IOWR	I	I3Z
36	-WE	I	I3U	-WE	I	I3U	-WE ⁽³⁾	I	I3U
37	READY	O	OT1	IREQ	O	OT1	INTRQ	O	OZ1
38	V _{CC}		Power	V _{CC}		Power	V _{CC}		Power
39	-CSEL ⁽²⁾⁽⁴⁾	I	I2Z	-CSEL	I	I2Z	-CSEL	I	I2U
40	-VS2	O	OPEN	-VS2	O	OPEN	-VS2	O	OPEN
41	RESET	I	I2Z	RESET	I	I2Z	-RESET	I	I2Z
42	-WAIT	O	OT1	-WAIT	O	OT1	IORDY	O	ON1
43	-INPACK	O	OT1	-INPACK	O	OT1	RFU	O	OZ1
44	-REG	I	I3U	-REG	I	I3U	RFU ⁽⁵⁾	I	I3U
45	BVD2	I/O	I1U,OT1	-SPKR	I/O	I1U,OT1	-DASP	I/O	I1U,ON1
46	BVD1	I/O	I1U,OT1	-STSCHG	I/O	I1U,OT1	-PDIAG	I/O	I1U,ON1
47	D08 ⁽²⁾	I/O	I1Z,OZ3	D08 ⁽²⁾	I/O	I1Z,OZ3	D08 ⁽²⁾	I/O	I1Z,OZ3
48	D09 ⁽²⁾	I/O	I1Z,OZ3	D09 ⁽²⁾	I/O	I1Z,OZ3	D09 ⁽²⁾	I/O	I1Z,OZ3
49	D10 ⁽²⁾	I/O	I1Z,OZ3	D10 ⁽²⁾	I/O	I1Z,OZ3	D10 ⁽²⁾	I/O	I1Z,OZ3
50	GND		Ground	GND		Ground	GND		Ground

1. The signal should be grounded by the host.
2. These signals are required only for 16 bit accesses and not required when installed in 8 bit systems. Devices should allow for 3-state signals not to consume current.
3. The signal should be tied to V_{CC} by the host.
4. The -CSEL signal is ignored by the card in PC Card modes. However, because it is not pulled up on the card in these modes it should not be left floating by the host in PC Card modes. In these modes, the pin is normally connected by the host to PC Card A25 or grounded by the host.
5. The signal should be held High or tied to V_{CC} by the host and RFU is Reserved for Future Use.

Table 9. Signal description

Signal name	Direction	Pin	Description
A10 to A0 (PC card memory mode)	I	8,10,11,12, 14,15,16,17, 18,19,20	Used (with –REG) to select: the I/O Port Address registers, the memory mapped Port Address registers, a byte in the card's information structure and its Configuration Control and Status registers.
A10 to A0 (PC card I/O mode)			Same as PC card memory mode.
A2 to A0 (True IDE mode)			Only A2 to A0 are used to select the one of eight registers in the task file, the remaining lines should be grounded.
BVD1 (PC card memory mode)	I/O	46	The battery voltage status of the card, as no battery is required it is asserted High.
–STSCHG (PC card I/O mode)			Alerts the host to changes in the READY and Write Protect states. Its use is controlled by the Card Configuration and Status register.
–PDIAG (True IDE mode)			The Pass Diagnostic signal in the master/slave handshake protocol.
BVD2 (PC card memory mode)	I/O	45	The battery voltage status of the card, as no battery is required it is asserted High.
–SPKR (PC card I/O mode)			The binary audio output from the card. It is asserted High as audio functions are not supported.
–DASP (True IDE mode)			This input/output is the disk active/slave present signal in the master/slave handshake protocol.
D15-D00 (PC card memory mode)	I/O	31,30,29,28, 27,49,48,47, 6,5,4,3,2, 23,22,21	Carry the data, commands and status information between the host and the controller. D00 is the LSB of the even byte of the word. D08 is the LSB of the odd byte of the word.
D15-D00 (PC card I/O mode)			Same as PC card memory mode.
D15-D00 (True IDE mode)			All task file operations occur in byte mode on D00 to D07 while all data transfers are 16 bit using D00 to D15.
GND (PC card memory mode)		1,50	Ground.
GND (PC card I/O mode)			Same for all modes.
GND (True IDE mode)			Same for all modes.
–INPACK (PC card memory mode)	O	43	Not used, should not be connected to the host.
–INPACK (PC card I/O mode)			The Input Acknowledge is asserted when the Card is selected and responding to an I/O read cycle at the current address on the bus. It is used by the host to control the enable of any input data buffers between the Card and CPU.
Reserved (True IDE mode)			Not used, should not be connected to the host.

Table 9. Signal description (continued)

Signal name	Direction	Pin	Description
-IORD (PC card memory mode)	I	34	Not used.
-IORD (PC card I/O mode)			I/O Read strobe generated by the host. It gates I/O data onto the bus.
-IORD (True IDE mode)			Same as PC card I/O mode.
-CD1, -CD2 (PC card memory mode)	O	26,25	These are connected to ground on the card. They are used by the host to determine that the card is fully inserted into its socket.
-CD1, -CD2 (PC card I/O mode)			Same for all modes.
-CD1, -CD2 (True IDE mode)			Same for all modes.
-CE1, -CE2 (PC card memory mode)	I	7,32	Used to select the card and to indicate whether a byte or a word operation is being performed. -CE2 accesses the odd byte, -CE1 accesses the even byte or the odd byte depending on A0 and -CE2. A multiplexing scheme based on A0, -CE1, -CE2 allows 8 bit hosts to access all data on D0 to D7.
-CE1, -CE2 (PC card I/O mode)			Same as PC card memory mode.
-CS0, -CS1 (True IDE mode)			CS0 is the chip select for the task file registers, while CS1 selects the Alternate Status register and the Device Control register.
-CSEL (PC card memory mode)			Not used.
-CSEL (PC card I/O mode)	I	39	Not used.
-CSEL (True IDE mode)			This internally pulled up signal is used to configure the card as a master or slave. When grounded it is configured as a master, when open it is configured as a slave.
-IOWR (PC card memory mode)	I	35	Not used.
-IOWR (PC card I/O mode)			The I/O Write strobe pulse is used to clock I/O data on the bus into the Card Controller registers. Clocking occurs on the rising edge.
-IOWR (True IDE mode)			Same as PC card I/O mode.
-OE (PC card memory mode)	I	9	This is an Output Enable strobe generated by the host interface. It reads data and the CIS and Configuration registers.
-OE (PC card I/O mode)			Reads the CIS and Configuration registers.
-ATASEL (True IDE mode)			Grounded by the host.

Table 9. Signal description (continued)

Signal name	Direction	Pin	Description
READY (PC card memory mode)	O	37	Indicates whether the card is busy (Low), or ready to accept a new data transfer operation (High). The Host socket must provide a pull-up resistor. At power-up and reset, the READY signal is held Low until the commands are completed. No access should be made during this time. The READY signal is held High whenever the card has been powered up with RESET continuously disconnected or asserted.
–IREQ (PC card I/O mode)			Interrupt request. It is strobed Low to generate a pulse mode interrupt or held Low for a level mode interrupt.
INTRQ (True IDE mode)			Active High Interrupt request to the host.
–REG (PC card memory mode)	I	44	Used to distinguish between common memory and register (attribute) memory accesses. High for common memory, Low for attribute memory.
–REG (PC card I/O mode)			Must be Low during I/O cycles when the I/O address is on the bus.
Reserved (True IDE mode)			Not used, should be connected to V _{CC} by the host.
RESET (PC card memory mode)	I	41	Resets the card (active High). The card is reset at power-up only if this pin is left High or unconnected.
RESET (PC card I/O mode)			Same as PC card memory mode.
–RESET (True IDE mode)			Hardware Reset from the host (active Low).
V _{CC} (PC card memory mode)		13,38	+5 V, +3.3 V power.
V _{CC} (PC card I/O mode)			Same for all modes.
V _{CC} (True IDE mode)			Same for all modes.
–VS1, –VS2 (PC card memory mode)	O	33,40	Voltage sense signals.–VS1 is grounded so that the CIS can be read at 3.3 volts and –VS2 is reserved by PCMCIA for a secondary voltage.
–VS1, –VS2 (PC card I/O mode)			Same for all modes.
–VS1, –VS2 (True IDE mode)			Same for all modes.
–WAIT (PC card memory mode)	O	42	ST CF does not assert the WAIT (IORDY) signal.
–WAIT (PC card I/O mode)			
IORDY (True IDE mode)			

Table 9. Signal description (continued)

Signal name	Direction	Pin	Description
-WE (PC card memory mode)	I	36	Driven by the host to strobe memory write data to the registers.
-WE (PC card I/O mode)			Used for writing to the configuration registers.
-WE (True IDE mode)			Not used, should be connected to V_{CC} by the host.
WP (PC card memory mode)	O	24	No write protect switch available. It is held Low after the completion of the reset initialization sequence.
-IOIS16 (PC card I/O mode)			Used for the 16 bit port (-IOIS16) function. Low indicates that a 16 bit or odd byte only operation can be performed at the addressed port.
-IOCS16 (True IDE mode)			Asserted Low when the card is expecting a word data transfer cycle.

4.2 Electrical specification

Table 10 defines the DC characteristics for the CompactFlash memory card. Unless otherwise stated, conditions are:

- $V_{CC} = 5\text{ V} \pm 10\%$
- $V_{CC} = 3.3\text{ V} \pm 10\%$
- $-40\text{ }^\circ\text{C}$ to $85\text{ }^\circ\text{C}$

Table 11 shows that the card operates correctly in both the voltage ranges and that the current requirements must not exceed the maximum limit shown.

Table 10. Absolute maximum conditions

Parameter	Symbol	Conditions
Input power	V_{CC}	-0.3 V to 6.5 V
Voltage on any pin except V_{CC} with respect to GND	V	-0.5 V to $V_{CC} + 0.5\text{ V}$

Table 11. Input power

Voltage	Maximum average RMS current	Measurement conditions
$3.3\text{ V} \pm 10\%$	79 mA	$-40 + 85\text{ }^\circ\text{C}$
$5\text{ V} \pm 10\%$	82 mA	$-40 + 85\text{ }^\circ\text{C}$

4.3 Current measurement

The current is measured by connecting an amp meter in series with the V_{CC} supply. The meter should be set to the 2 A scale range, and have a fast current probe with an RC filter with a time constant of 0.1 ms. Current measurements are taken while looping on a data transfer command with a sector count of 128. Current consumption values for both read and write commands are not to exceed the maximum average RMS current specified in Table 11. Table 12 shows the Input leakage current, Table 13 the Input characteristics, Table 14 the Output drive type and Table 15 the Output drive characteristics.

Table 12. Input leakage current⁽¹⁾

Type	Parameter	Symbol	Conditions	Min	Typ	Max	Units
IxZ	Input leakage current	IL	$V_{IH} = V_{CC}$	-1		1	μA
			$V_{IL} = \text{GND}$				
IxU	Pull up resistor	RPU1	$V_{CC} = 5.0\text{ V}$	50		500	kW
IxD	Pull down resistor	RPD1	$V_{CC} = 5.0\text{ V}$	50		500	kW

1. x refers to the characteristics described in Table 13. For example, I1U indicates a pull up resistor with a type 1 input characteristic.

Table 13. Input characteristics

Type	Parameter	Symbol	Min	Typ	Max	Min	Typ	Max	Units
			$V_{CC} = 3.3\text{ V}$			$V_{CC} = 5.0\text{ V}$			
1	Input voltage CMOS	V_{IH}	2.4			2.4			V
		V_{IL}			0.6			0.8	
2	Input voltage CMOS	V_{IH}	1.5			2.0			V
		V_{IL}			0.6			0.8	
3	Input voltage CMOS Schmitt Trigger	V_{TH}		1.8			2.8		V
		V_{TL}		1.0			2.0		

Table 14. Output drive type⁽¹⁾

Type	Output type	Valid conditions
OTx	Totem pole	I_{OH} & I_{OL}
OZx	Tri-state N-P channel	I_{OH} & I_{OL}
OPx	P-channel only	I_{OH} only
ONx	N-channel only	I_{OL} only

1. x refers to the characteristics described in Table 15. For example, OT3 refers to totem pole output with a type 3 output drive characteristic.

Table 15. Output drive characteristics

Type	Parameter	Symbol	Conditions	Min	Typ	Max	Units
1	Output voltage	V_{OH}	$I_{OH} = -4\text{ mA}$	$V_{CC} - 0.8\text{ V}$			V
		V_{OL}	$I_{OL} = 4\text{ mA}$			Gnd + 0.4 V	
2	Output voltage	V_{OH}	$I_{OH} = -8\text{ mA}$	$V_{CC} - 0.8\text{ V}$			V
		V_{OL}	$I_{OL} = 8\text{ mA}$			Gnd + 0.4 V	
3	Output voltage	V_{OH}	$I_{OH} = -8\text{ mA}$	$V_{CC} - 0.8\text{ V}$			V
		V_{OL}	$I_{OL} = 8\text{ mA}$			Gnd + 0.4 V	
X	Tri-state leakage current	I_{OZ}	$V_{OL} = \text{Gnd}$	-10		10	μA
			$V_{OH} = V_{CC}$				

5 Command interface

There are two types of bus cycles and timing sequences that occur in the PCMCIA type interface, direct mapped I/O transfer and memory access. [Table 16](#), [Table 17](#), [Table 18](#), [Table 19](#), [Table 20](#), [Table 21](#) and [Table 22](#) show the read and write timing parameters. [Figure 2](#), [Figure 3](#), [Figure 4](#), [Figure 5](#), [Figure 6](#), [Figure 7](#) and [Figure 8](#) show the read and write timing diagrams.

Note, the wait width time is intentionally less than the PCMCIA specification of 12 μ s. Its maximum value can be determined from the card information structure.

Figure 2. Attribute memory Read timing diagram

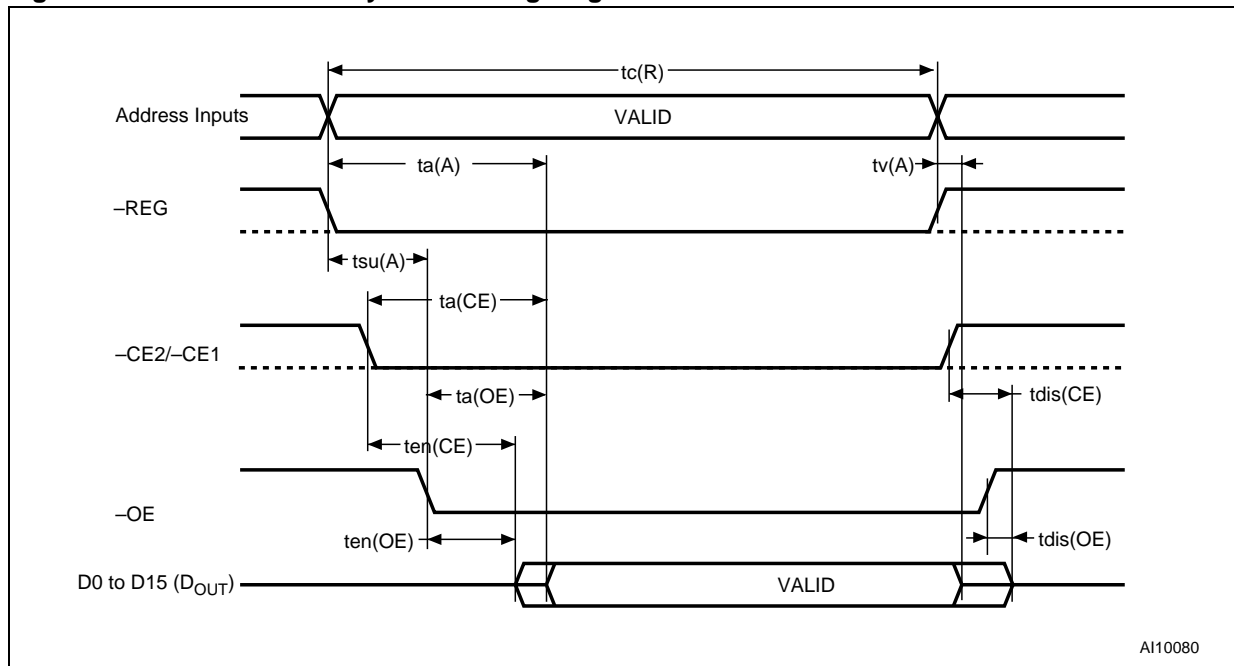

1. D_{OUT} signifies data provided by the CompactFlash memory card to the system. The -CE signal or both the -OE signal and the -WE signal must be de-asserted between consecutive cycle operations.

Table 16. Attribute memory Read timing

Speed version			300 ns		
Symbol	IEEE symbol	Parameter	Min	Max	Unit
tc(R)	t_{AVAV}	Read Cycle time	300		ns
ta(A)	t_{AVQV}	Address Access time		300	ns
ta(CE)	t_{ELQV}	CE Access time		300	ns
ta(OE)	t_{GLQV}	OE Access time		150	ns
tdis(CE)	t_{EHQZ}	Output Disable time from CE		100	ns
tdis(OE)	t_{GHQZ}	Output Disable time from OE		100	ns
ten(CE)	t_{ELQNZ}	Output Enable time from CE	5		ns
ten(OE)	t_{GLQNZ}	Output Enable time from OE	5		ns
tv(A)	t_{AXQX}	Data Valid from Address Change	0		ns
tsu(A)	t_{AVGL}	Address Setup time	30		ns

Figure 3. Configuration register (attribute memory) Write timing diagram

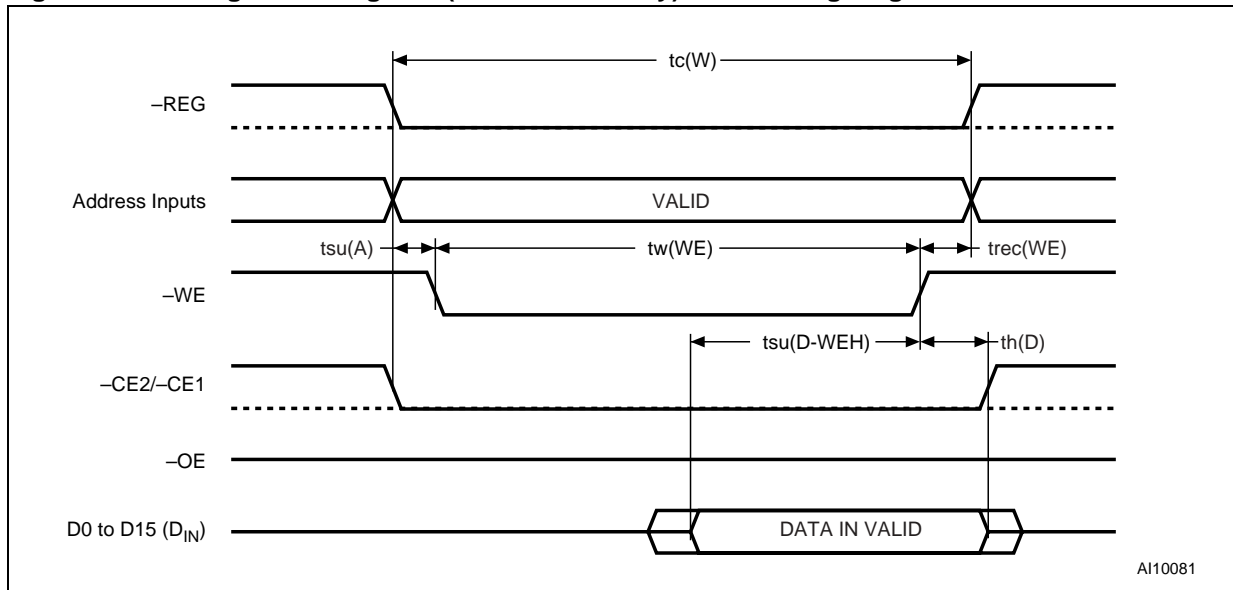

1. D_{IN} signifies data provided by the system to the CompactFlash card.

Table 17. Configuration register (attribute memory) Write timing

Speed version			250 ns		
Symbol	IEEE symbol	Parameter	Min	Max	Unit
$t_c(W)$	t_{AVAV}	Write Cycle time	250		ns
$t_w(WE)$	t_{WLWH}	Write Pulse width	150		ns
$t_{su}(A)$	t_{AVWL}	Address Setup time	30		ns
$t_{su}(D-WEH)$	t_{DVWH}	Data Setup time from WE	80		ns
$t_h(D)$	t_{WMDX}	Data Hold time	30		ns
$t_{rec}(WE)$	t_{WMAX}	Write Recovery time	30		ns

Figure 4. Common memory Read timing diagram

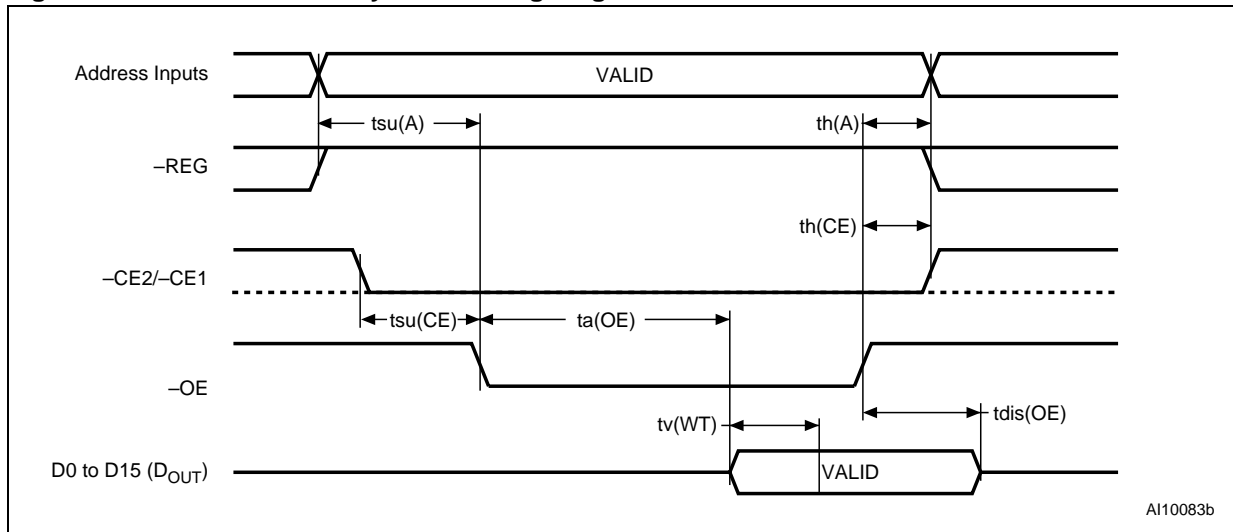

1. D_{OUT} means data provided by the CompactFlash memory card to the system.

Table 18. Common memory Read timing⁽¹⁾

Cycle time mode			250 ns		
Symbol	IEEE symbol	Parameter	Min	Max	Unit
$t_{a}(OE)$	t_{GLQV}	Output Enable Access time		125	ns
$t_{dis}(OE)$	t_{GHQZ}	Output Disable time from OE		100	ns
$t_{su}(A)$	t_{AVGL}	Address Setup time	30		ns
$t_{th}(A)$	t_{GHAX}	Address Hold time	20		ns
$t_{su}(CE)$	t_{ELGL}	CE Setup time	0		ns
$t_{th}(CE)$	t_{GHEH}	CE Hold time	20		ns

1. ST CF does not assert the WAIT signal.

Figure 5. Common memory Write timing diagram

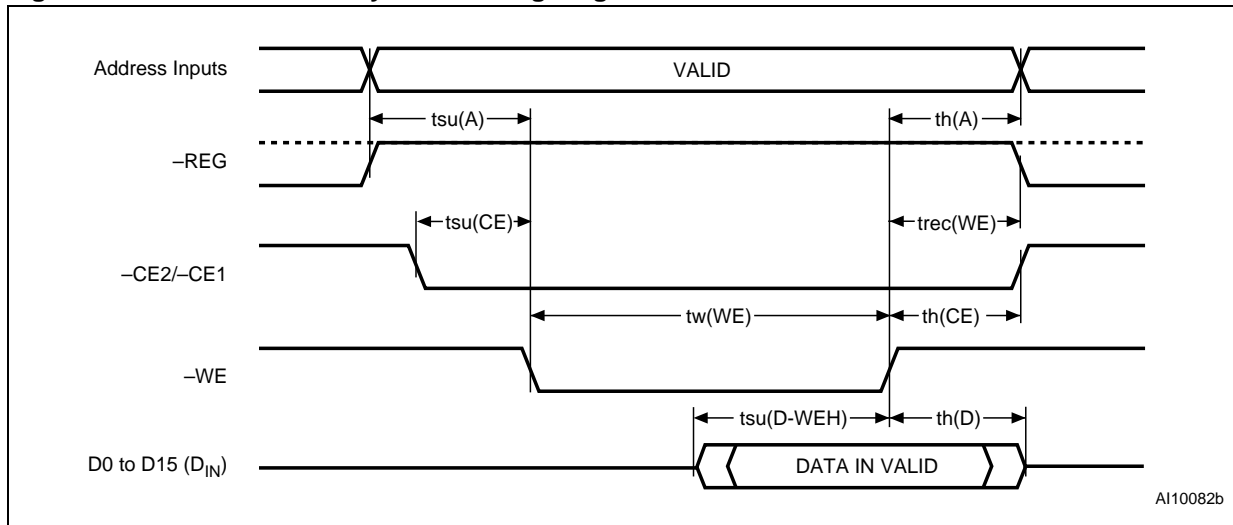

1. D_{IN} signifies data provided by the system to the CompactFlash memory card.

Table 19. Common memory Write timing⁽¹⁾

Cycle time mode			250 ns		
Symbol	IEEE symbol	Parameter	Min	Max	Unit
$t_{su}(D-WEH)$	t_{DVWH}	Data setup time from WE	80		ns
$t_{th}(D)$	t_{WMDX}	Data hold time	30		ns
$t_w(WE)$	t_{WLWH}	WE pulse width	150		ns
$t_{su}(A)$	t_{AVGL}	Address setup time	30		ns
$t_{su}(CE)$	t_{ELWL}	CE setup time before WE	0		ns
$t_{rec}(WE)$	t_{WMAX}	Write recovery time	30		ns
$t_{th}(A)$	t_{GHAX}	Address hold time	20		ns
$t_{th}(CE)$	t_{GHEH}	CE hold following WE	20		ns

1. ST CF does not assert the WAIT signal.

Figure 6. I/O Read timing diagram

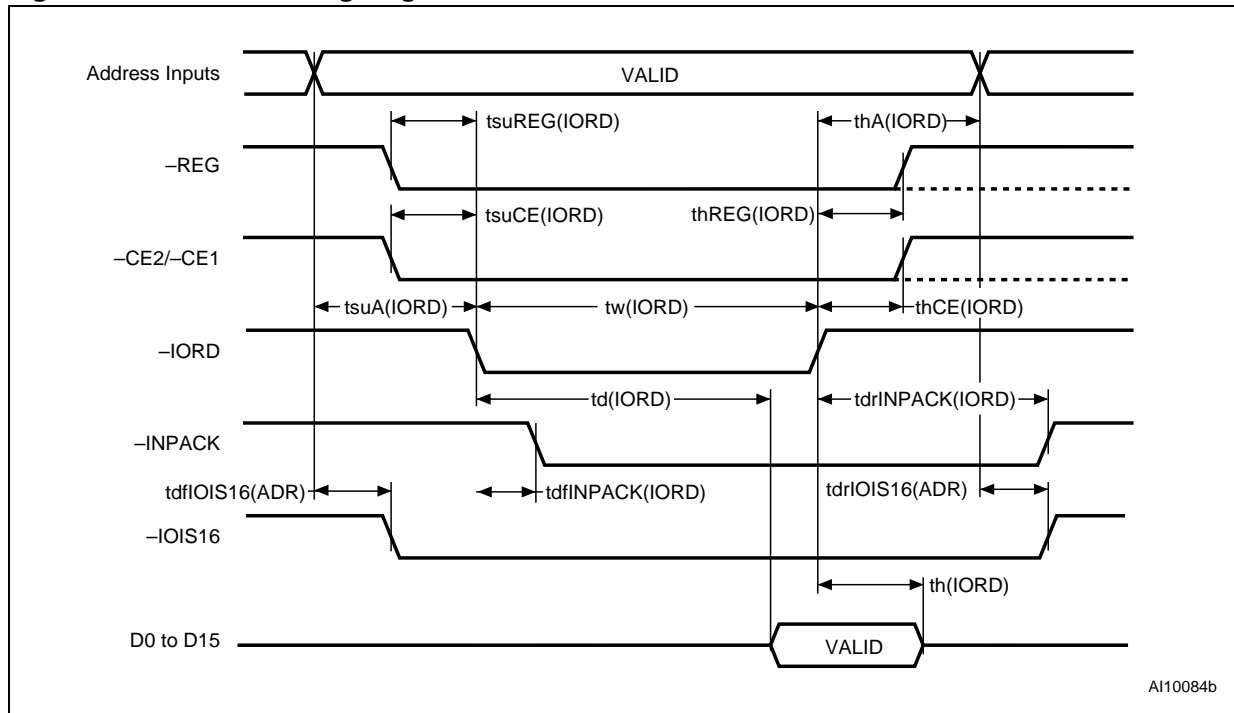

1. D_{OUT} signifies data provided by the CompactFlash memory card or to the system.

Table 20. I/O Read timing⁽¹⁾

Cycle time mode			250 ns		
Symbol	IEEE symbol	Parameter	Min	Max	Unit
td(IORD)	t _{IGLQV}	Data Delay after IORD		100	ns
th(IORD)	t _{IGHQX}	Data Hold following IORD	0		ns
tw(IORD)	t _{IGLIGH}	IORD Width time	165		ns
tsuA(IORD)	t _{AVIGL}	Address Setup before IORD	70		ns
thA(IORD)	t _{IGHAX}	Address Hold following IORD	20		ns
tsuCE(IORD)	t _{ELIGL}	CE Setup before IORD	5		ns
thCE(IORD)	t _{IGHEH}	CE Hold following IORD	20		ns
tsuREG(IORD)	t _{RGLIGL}	REG Setup before IORD	5		ns
thREG(IORD)	t _{IGHRGH}	REG Hold following IORD	0		ns
tdfINPACK(IORD)	t _{IGLIAL}	INPACK Delay Falling from IORD	0	45	ns
tdrINPACK(IORD)	t _{IGHIAH}	INPACK Delay Rising from IORD		45	ns
tdfIOIS16(A)	t _{AVISL}	IOIS16 Delay Falling from Address		35	ns
tdrIOIS16(A)	t _{AVISH}	IOIS16 Delay Rising from Address		35	ns

1. ST CF does not assert the WAIT signal.

Figure 7. I/O Write timing diagram

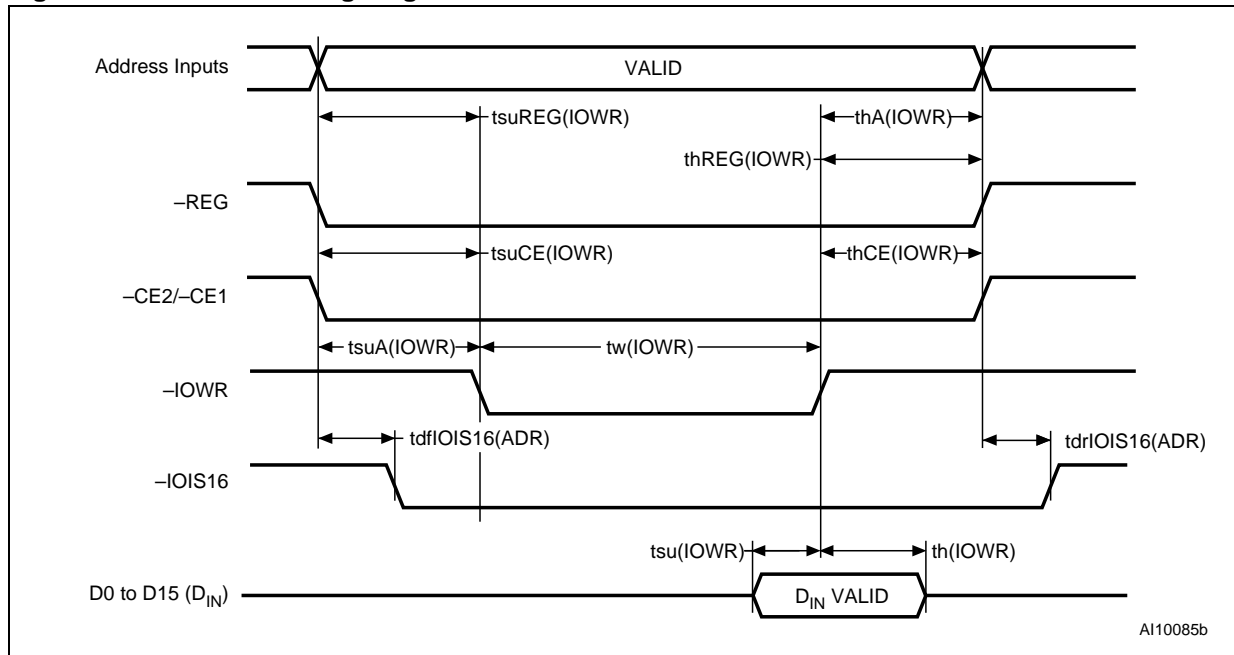

1. D_{IN} signifies data provided by the system to the CompactFlash memory card or CF+ card.

Table 21. I/O Write timing⁽¹⁾

Cycle time mode			250 ns		
Symbol	IEEE symbol	Parameter	Min	Max	Unit
$t_{\text{su(IOWR)}}$	t_{QVIWH}	Data Setup before IOWR	60		ns
$t_{\text{th(IOWR)}}$	t_{IWHQX}	Data Hold following IOWR	30		ns
$t_{\text{tw(IOWR)}}$	$t_{\text{IWL IWH}}$	IOWR Width time	165		ns
$t_{\text{suA(IOWR)}}$	t_{AVIWL}	Address Setup before IOWR	70		ns
$t_{\text{thA(IOWR)}}$	t_{IWHAX}	Address Hold following IOWR	20		ns
$t_{\text{suCE(IOWR)}}$	t_{ELIWL}	CE Setup before IOWR	5		ns
$t_{\text{thCE(IOWR)}}$	t_{IWHEH}	CE Hold following IOWR	20		ns
$t_{\text{suREG(IOWR)}}$	t_{RGLIWL}	REG Setup before IOWR	5		ns
$t_{\text{thREG(IOWR)}}$	t_{IWHRGH}	REG Hold following IOWR	0		ns
$t_{\text{dfIOIS16(A)}}$	t_{AVISL}	IOIS16 Delay Falling from Address		35	ns
$t_{\text{drIOIS16(A)}}$	t_{AVISH}	IOIS16 Delay Rising from Address		35	ns

1. ST CF does not assert the WAIT signal.

The timing diagram for True IDE mode of operation in this section is drawn using the conventions in the ATA-4 specification, which are different than the conventions used in the PCMCIA specification and earlier versions of this specification. Signals are shown with their asserted state as High regardless of whether the signal is actually negative or positive true. Consequently, the -IOR_D, the -IOW_R and the -IOCS₁₆ signals are shown in the diagram inverted from their electrical states on the bus.

Figure 8. True IDE mode I/O timing diagram

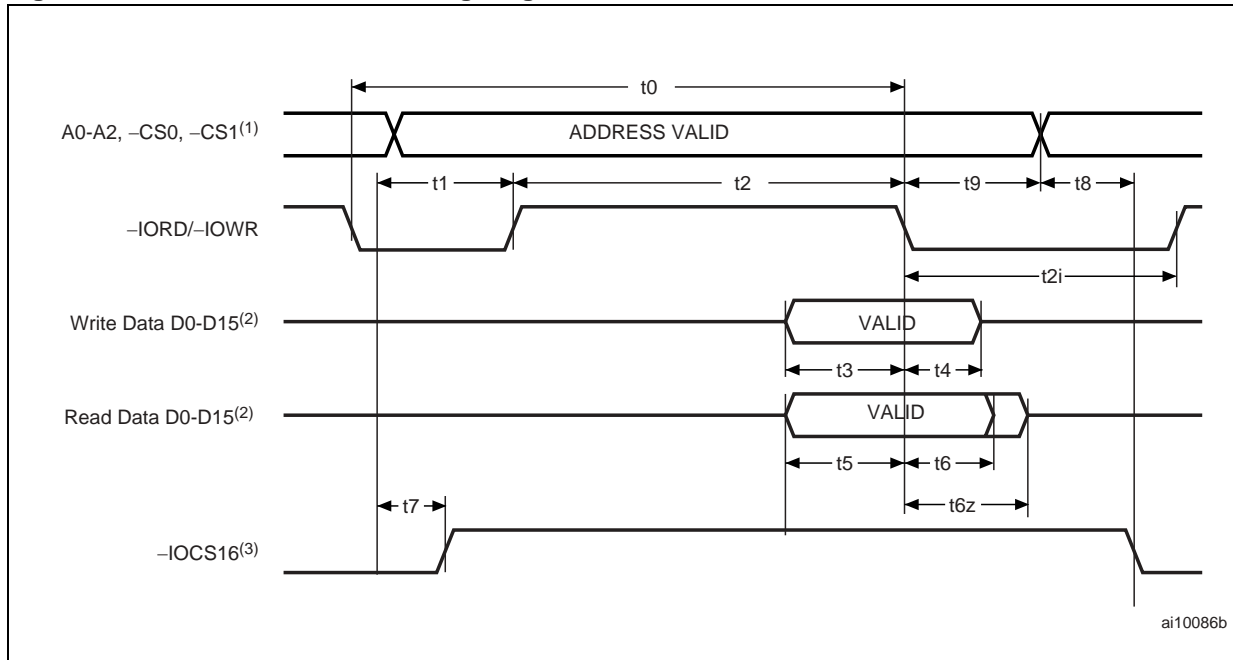

1. The device addresses consists of -CS₀, -CS₁, and A₂-A₀.
2. The Data I/O consist of D₁₅-D₀ (16 bit) or D₇-D₀ (8 bit).
3. -IOCS₁₆ is shown for PIO modes 0, 1 and 2. For other modes, this signal is ignored.

Table 22. True IDE mode I/O Read/Write timing diagram

Symbol	Parameter ⁽¹⁾	Mode 0	Mode 1	Mode 2	Mode 3	Mode 4	Unit
$t_0^{(2)}$	Cycle time (min)	600	383	240	180	120	ns
t_1	Address Valid to -IORD/-IOWR setup (min)	70	50	30	30	25	ns
$t_2^{(2)}$	-IORD/-IOWR (min)	165	125	100	80	70	ns
$t_2^{(2)}$	-IORD/-IOWR (min) register (8 bit)	290	290	290	80	70	ns
$t_{2i}^{(2)}$	-IORD/-IOWR recovery time (min)	-	-	-	70	25	ns
t_3	-IOWR data setup (min)	60	45	30	30	20	ns
t_4	-IOWR data hold (min)	30	20	15	10	10	ns
t_5	-IORD data setup (min)	50	35	20	20	20	ns
t_6	-IORD data hold (min)	5	5	5	5	5	ns
$t_{6Z}^{(3)}$	-IORD data tri-state (max)	30	30	30	30	30	ns
$t_7^{(4)}$	Address valid to -IOCS16 assertion (max)	90	50	40	N/A	N/A	ns
$t_8^{(4)}$	Address valid to -IOCS16 released (max)	60	45	30	N/A	N/A	ns
t_9	-IORD/-IOWR to address valid hold	20	15	10	10	10	ns

1. The maximum load on -IOCS16 is 1 LSTTL with a 50 pF total load.
2. t_0 is the minimum total cycle time, t_2 is the minimum command active time, and t_{2i} is the minimum command recovery time or command inactive time. The actual cycle time equals the sum of the actual command active time and the actual command inactive time. The three timing requirements of t_0 , t_2 , and t_{2i} have to be met. The minimum total cycle time requirement is greater than the sum of t_2 and t_{2i} . This means a host implementation can lengthen either or both t_2 or t_{2i} to ensure that t_0 is equal to or greater than the value reported in the device's identify drive data. A CompactFlash memory card implementation should support any legal host implementation.
3. This parameter specifies the time from the falling edge of -IORD to the moment when the data bus is no longer driven by the CompactFlash memory card (tri-state).
4. t_7 and t_8 apply only to modes 0, 1 and 2. This signal is not valid for other modes.

6 Card configuration

The CompactFlash memory card is identified by information in the card information structure (CIS). The card has four Configuration registers ([Table 23](#) and [Table 24](#)).

- Configuration Option register
- Pin Replacement register
- Card Configuration and Status register
- Socket and Copy register

They are used to coordinate the I/O spaces and the Interrupt level of cards that are located in the system. In addition, in I/O Card mode these registers provide a method for accessing status information that would normally appear on dedicated pins in Memory Card mode. The location of the Card Configuration registers should always be read from the CIS. These registers cannot be used in True IDE mode.

No writes should be performed to the attribute memory except to the Configuration register addresses. All other attribute memory locations are reserved. See [Section 6.5: Attribute memory function](#).

Table 23. CompactFlash memory card registers and memory space decoding

-CE2	-CE1	-REG	-OE	-WE	A10	A9	A8-A4	A3	A2	A1	A0	Selected space
1	1	X	X	X	X	X	XXX	XX	X	X	X	Standby
X	0	0	0	1	0	1	XXX	XX	X	X	0	Configuration registers Read
1	0	1	0	1	X	X	XXX	XX	X	X	X	Common Memory Read (D7 to D0)
0	1	1	0	1	X	X	XXX	XX	X	X	X	Common Memory Read (D15 to D8)
0	0	1	0	1	X	X	XXX	XX	X	X	0	Common Memory Read (D15 to D0)
X	0	0	1	0	0	1	XXX	XX	X	X	0	Configuration registers Write
1	0	1	1	0	X	X	XXX	XX	X	X	X	Common Memory Write (D7 to D0)
0	1	1	1	0	X	X	XXX	XX	X	X	X	Common Memory Write (D15 to D8)
0	0	1	1	0	X	X	XXX	XX	X	X	0	Common Memory Write (D15 to D0)
X	0	0	0	1	0	0	XXX	XX	X	X	0	Card Information Structure Read
1	0	0	1	0	0	0	XXX	XX	X	X	0	Invalid Access (CIS Write)
1	0	0	0	1	X	X	XXX	XX	X	X	1	Invalid Access (Odd Attribute Read)
1	0	0	1	0	X	X	XXX	XX	X	X	1	Invalid Access (Odd Attribute Write)
0	1	0	0	1	X	X	XXX	XX	X	X	X	Invalid Access (Odd Attribute Read)
0	1	0	1	0	X	X	XXX	XX	X	X	X	Invalid Access (Odd Attribute Write)

Table 24. CompactFlash memory card configuration registers decoding

-CE2	-CE1	-REG	-OE	-WE	A10	A9	A8-A4	A3	A2	A1	A0	Selected register
X	0	0	0	1	0	1	00	0	0	0	0	Configuration Option register Read
X	0	0	1	0	0	1	00	0	0	0	0	Configuration Option register Write
X	0	0	0	1	0	1	00	0	0	1	0	Card Status register Read
X	0	0	1	0	0	1	00	0	0	1	0	Card Status register Write
X	0	0	0	1	0	1	00	0	1	0	0	Pin Replacement register Read
X	0	0	1	0	0	1	00	0	1	0	0	Pin Replacement register Write
X	0	0	0	1	0	1	00	0	1	1	0	Socket and Copy register Read
X	0	0	1	0	0	1	00	0	1	1	0	Socket and Copy register Write

6.1 Configuration Option register (base + 00h in attribute memory)

The Configuration Option register is used to configure the card's interface, address decoding and interrupt to the card (see [Table 25](#)).

6.1.1 LevIREQ

This bit is set to one (1) when level mode interrupt is selected, and zero (0) when pulse mode is selected. Set to zero (0) after power-up.

6.1.2 Conf5 - Conf0 (configuration index)

These bits are used to select the operation mode of the card as shown in [Table 26](#). This bit is set to '0' after power-up.

Table 25. Configuration Option register (default value: 00h)

Operation	D7	D6	D5	D4	D3	D2	D1	D0
R/W	X	LevIREQ	Conf5	Conf4	Conf3	Conf2	Conf1	Conf0

Table 26. CompactFlash memory card configurations

Conf 5	Conf 4	Conf 3	Conf 2	Conf 1	Conf 0	Mapping mode	Card mode	Task file register address
0	0	0	0	0	0	Memory	Memory	0h - Fh, 400h - 7FFh
0	0	0	0	0	1	Contiguous I/O	I/O	xx0h - xxFh
0	0	0	0	1	0	Primary I/O	I/O	1F0h - 1F7h, 3F6h - 3F7h
0	0	0	0	1	1	Secondary I/O	I/O	170h - 177h, 376h - 377h

6.2 Card Configuration and Status register (base + 02h in attribute memory)

The Card Configuration and Status register contains information about the card's status (see [Table 27](#)).

6.2.1 Changed

Indicates that one or both of the pin replacement register (CRDY, or CWProt) bits are set to '1'. When the Changed bit is set, -STSCHG (pin 46) is held Low and if the SigChg bit is '1' the card is configured for the I/O interface.

6.2.2 SigChg

This bit is set and reset by the host to enable and disable a state-change signal from the Status register (issued on Status Changed pin 46). If no state change signal is desired, this bit should be set '0' and pin 46 (-STSCHG) will be held High while the card is configured for I/O.

6.2.3 IOIS8

The host sets this bit to '1' if the card is to be configured in 8 bit I/O mode. The card is always configured for both 8 and 16 bit I/O, so this bit is ignored.

6.2.4 PwrDwn

This bit indicates whether the card is in the power saving mode or active mode. When the PwrDwn bit is set to '1', the card enters power-down mode. When set to '0', the card enters active mode. The READY value on Pin Replacement register becomes BUSY when this bit is changed. READY will not become Ready until the power state requested has been entered. The card automatically powers down when it is idle and powers back up when it receives a command.

6.2.5 Int

This bit represents the internal state of the interrupt request. It is available whether or not the I/O interface has been configured. It remains valid until the condition which caused the interrupt request has been serviced. If interrupts are disabled by the -IEN bit in the Device Control register, this bit is '0'.

Table 27. Card Configuration and Status register (default value: 00h)

Operation	D7	D6	D5	D4	D3	D2	D1	D0
Read	Changed	SigChg	IOIS8	0	0	PwrDwn	Int	0
Write	0	SigChg	IOIS8	0	0	PwrDwn	0	0

6.3 Pin Replacement register (base + 04h in attribute memory)

This register contains information on the state of the READY signal when configured in memory mode and the IREQ signal in I/O mode. See [Table 28](#) and [Table 29](#).

6.3.1 CReady

This bit is set to '1' when the bit RReady changes state. This bit can also be written by the host.

6.3.2 CWProt

This bit is set to '1' when the bit RWProt changes state. This bit can also be written by the host.

6.3.3 RReady

This bit is used to determine the internal state of the Ready signal. In I/O mode it is used as an interrupt request. When written, this bit acts as a mask (MReady) for writing the corresponding bit CReady.

6.3.4 WProt

This bit is always '0' since the CompactFlash memory card does not have a Write Protect switch. When written, this bit acts as a mask for writing the corresponding CWProt bit.

6.3.5 MReady

This bit acts as a mask for writing the corresponding CReady bit.

6.3.6 MWProt

This bit when written acts as a mask for writing the corresponding CWProt bit.

Table 28. Pin Replacement register (default value: 0Ch)

Operation	D7	D6	D5	D4	D3	D2	D1	D0
Read	0	0	CReady	CWProt	1	1	RReady	WProt
Write	0	0	CReady	CWProt	0	0	RReady	MWProt

Table 29. Pin Replacement Changed bit/Mask bit values

Initial value of 'C' status	Written by host		Final 'C' bit	Comments
	'C' bit	'M' bit		
0	X	0	0	Unchanged
1	X	0	1	Unchanged
X	0	1	0	Cleared by host
X	1	1	1	Set by host

6.4 Socket and Copy register (base + 06h in attribute memory)

This register contains additional configuration information which identifies the card from other cards. This register is always written by the system before writing the Configuration Option register (see [Table 30](#)).

6.4.1 Drive

This value can be used to address two different cards in the case of twin card configuration.

6.4.2 X

The socket number is ignored by the card.

Table 30. Socket and Copy register (default value: 00h)

Operation	D7	D6	D5	D4	D3	D2	D1	D0
Read	Reserved	0	0	Drive #	0	0	0	0
Write	0	0	0	Drive #	X	X	X	X

6.5 Attribute memory function

Attribute memory is a space where identification and configuration information are stored, and is limited to 8 bit wide accesses at even addresses. The Card Configuration registers are also located here, the base address of the configuration registers is 200h.

For the attribute memory Read function, signals -REG and -OE must be active and -WE inactive during the cycle. As in the main memory read functions, the signals -CE1 and -CE2 control the even and odd byte address, but only the even byte data is valid during the attribute memory access. Refer to [Table 31](#) for signal states and bus validity.

Table 31. Attribute memory function⁽¹⁾

Function mode	-REG	-CE2	-CE1	A10	A9	A0	-OE	-WE	D15 to D8	D7 to D0
Standby	X	H	H	X	X	X	X	X	High-Z	High-Z
Read Byte Access CIS (8 bits)	L	H	L	L	L	L	L	H	High-Z	Even byte
Write Byte Access CIS (8 bits) Invalid	L	H	L	L	L	L	H	L	Don't care	Even byte
Read Byte Access Configuration (8 bits)	L	H	L	L	H	L	L	H	High-Z	Even byte
Write Byte Access Configuration (8 bits)	L	H	L	L	H	L	H	L	Don't care	Even byte
Read Byte Access Configuration CF+ (8 bits)	L	H	L	X	X	L	L	H	High-Z	Even byte
Read Word Access CIS (16 bits)	L	L	L	L	L	X	L	H	Not valid	Even byte
Write Word Access CIS (16 bits) Invalid	L	L	L	L	L	X	H	L	Don't care	Even byte
Read Word Access Configuration (16 bits)	L	L	L	L	H	X	L	H	Not valid	Even byte
Write Word Access Configuration (16 bits)	L	L	L	L	H	X	H	L	Don't care	Even byte

1. The -CE signal or both the -OE signal and the -WE signal must be de-asserted between consecutive cycle operations.

6.6 I/O transfer function

The I/O transfer to or from the card can be either 8 or 16 bits. When a 16 bit accessible port is addressed, the -IOIS16 signal is asserted by the card, otherwise it is de-asserted. When a 16 bit transfer is attempted, and the -IOIS16 signal is not asserted, the system must generate a pair of 8 bit references to access the word's even and odd bytes. The card permits both 8 and 16 bit accesses to all of its I/O addresses, so -IOIS16 is asserted for all addresses (see [Table 32](#)).

Table 32. I/O function

Function code	-REG	-CE2	-CE1	A0	-IOR	-IOWR	D15 to D8	D7 to D0
Standby mode	X	H	H	X	X	X	High Z	High Z
Byte input access (8 bits)	L	H	L	L	L	H	High Z	Even byte
	L	H	L	H	L	H	High Z	Odd byte
Byte output access (8 bits)	L	H	L	L	H	L	Don't care	Even byte
	L	H	L	H	H	L	Don't care	Odd byte
Word input access (16 bits)	L	L	L	L	L	H	Odd byte	Even byte
Word output access (16 bits)	L	L	L	L	H	L	Odd byte	Even byte
I/O Read Inhibit	H	X	X	X	L	H	Don't care	Don't care
I/O Write inhibit	H	X	X	X	H	L	High Z	High Z
High byte input only (8 bits)	L	L	H	X	L	H	Odd byte	High Z
High byte output only (8 bits)	L	L	H	X	H	L	Odd byte	Don't care

6.7 Common memory transfer function

The common memory transfer to or from the card permits both 8 or 16 bit access to all of the common memory addresses. (see [Table 33](#)).

Table 33. Common memory function

Function code	-REG	-CE2	-CE1	A0	-OE	-WE	D15 to D8	D7 to D0
Standby mode	X	H	H	X	X	X	High Z	High Z
Byte Read access (8 bits)	H H	H H	L L	L H	L L	H H	High Z High Z	Even byte Odd byte
Byte Write access (8 bits)	H H	H H	L L	L H	H H	L L	Don't care Don't care	Even byte Odd byte
Word Read access (16 bits)	H	L	L	X	L	H	Odd byte	Even byte
Word Write access (16 bits)	H	L	L	X	H	L	Odd byte	Even byte
Odd byte read only (8 bits)	H	L	H	X	L	H	Odd byte	High Z
Odd byte write only (8 bits)	H	L	H	X	H	L	Odd byte	Don't care

6.8 True IDE mode I/O function

The card can be configured in a True IDE mode of operation. It is configured in this mode only when the -OE signal is grounded by the host during the power-off to power-on cycle. In this True IDE mode the PCMCIA protocol and configuration are disabled and only I/O operations to the task file and data register are allowed. No memory or attribute registers are accessible to the host. The Set Feature command can be used to put the device in 8 bit mode (see [Table 34](#)).

Removing and reinserting the card while the host computer's power is on will reconfigure the card to PC Card ATA mode.

Table 34. True IDE mode I/O function

Function code	-CE2	-CE1	A2 to A0	-IORD	-IOWR	D15 to D8	D7 to D0
Invalid mode	L	L	X	X	X	High Z	High Z
Standby mode	H	H	X	X	X	High Z	High Z
Task File Write	H	L	1h-7h	H	L	Don't care	Data In
Task File Read	H	L	1h-7h	L	H	High Z	Data Out
Data Register Write	H	L	L	H	L	Odd-byte In	Even-byte In
Data Register Read	H	L	L	L	H	Odd-byte Out	Even-byte Out
Control Register Write	L	H	6h	H	L	Don't care	Control In
Alternate Status Read	L	H	6h	L	H	High Z	Status Out
Drive Address	L	H	7h	L	H	High Z	Data Out

7 Software interface

7.1 CF-ATA Drive register set definition and protocol

The CompactFlash memory card can be configured as a high performance I/O device through:

- Standard PC-AT disk I/O address spaces
 - 1F0h-1F7h, 3F6h-3F7h (primary);
 - 170h-177h, 376h-377h (secondary) with IRQ 14 (or other available IRQ).
- Any system decoded 16 byte I/O block using any available IRQ.
- Memory space.

Communication to or from the card is done using the Task File registers which provide all the necessary registers for control and status information. The PCMCIA interface connects peripherals to the host using four-register mapping methods. [Table 35](#) is a detailed description of these methods:

Table 35. I/O configurations

Standards configurations			
Config index	I/O or memory	Address	Description
0	Memory	0h-Fh, 400h-7FFh	Memory mapped
1	I/O	xx0h-xxFh	I/O mapped 16 continuous registers
2	I/O	1F0-1F7h, 3F6h-3F7h	Primary I/O mapped
3	I/O	170-177h, 376h-377h	Secondary I/O mapped

7.2 Memory mapped addressing (conf = 0)

When the card registers are accessed via memory references, the registers appear in the common memory space window: 0-2 Kbytes as shown in [Table 36](#). This window accesses the Data register FIFO. It does not allow random access to the data buffer within the card.

Register 0 is accessed with --CE1 and --CE2 Low, as a word register on the combined Odd and Even Data Bus (D15 to D0). It can also be accessed with --CE1 Low and --CE2 High, by a pair of byte accesses to offset 0. The address space of this word register overlaps the address space of the error and feature bitwise registers at offset 1. When accessed twice as byte register with --CE1 Low, the first byte is the even byte of the word and the second is the odd byte. A byte access to address 0 with --CE1 High and --CE2 Low accesses the error (read) or feature (write) register.

Registers at offset 8, 9 and D are non-overlapping duplicates of the registers at offset 0 and 1. Register 8 is equivalent to register 0, while register 9 accesses the odd byte. Therefore, if the registers are byte accessed in the order 9 then 8 the data will be transferred odd byte then even byte. Repeated byte accesses to register 8 or 0 will access consecutive (even then odd) bytes from the data buffer. Repeated word accesses to register 8, 9 or 0 will access consecutive words from the data buffer, however repeated byte accesses to register 9 are not supported. Repeated alternating byte accesses to registers 8 then 9 will access consecutive (even then odd) bytes from the data buffer.

Accesses to even addresses between 400h and 7FFh access register 8. Accesses to odd addresses between 400h and 7FFh access register 9. This 1 Kbyte memory window to the data register is provided so that hosts can perform memory-to-memory block moves to the data register when the register lies in memory space. Some hosts, such as the X86 processors, must increment both the source and destination addresses when executing the memory-to-memory block move instruction. Some PCMCIA socket adapters also have an embedded auto incrementing address logic.

A word access to address at offset 8 will provide even data on the least significant byte of the data bus, along with odd data at offset 9 on the most significant byte of the data bus.

Table 36. Memory mapped decoding

-REG	A10	A9 to A4	A3	A2	A1	A0	Offset	-OE=0	-WE=0
1	0	X	0	0	0	0	0h	Even Data register	Even Data register
1	0	X	0	0	0	1	1h	Error register	Feature register
1	0	X	0	0	1	0	2h	Sector Count register	Sector Count register
1	0	X	0	0	1	1	3h	Sector Number register	Sector Number register
1	0	X	0	1	0	0	4h	Cylinder Low register	Cylinder Low register
1	0	X	0	1	0	1	5h	Cylinder High register	Cylinder High register
1	0	X	0	1	1	0	6h	Select Card/Head register	Select card/Head register
1	0	X	0	1	1	1	7h	Status register	Command register
1	0	X	1	0	0	0	8h	Dup. Even Data register	Dup. Even Data register
1	0	X	1	0	0	1	9h	Dup. Odd Data register	Dup. Odd Data register
1	0	X	1	1	0	1	Dh	Dup. Error register	Dup. Feature register
1	0	X	1	1	1	0	Eh	Alternate Status register	Device Control register
1	0	X	1	1	1	1	Fh	Drive Address register	Reserved
1	1	X	X	X	X	0	8h	Even Data register	Even Data register
1	1	X	X	X	X	1	9h	Odd Data register	Odd Data register

7.3 Contiguous I/O mapped addressing (conf = 1)

When the system decodes a contiguous block of I/O registers to select the card, the registers are accessed in the block of I/O space decoded by the system as shown in [Table 37](#).

As for the memory mapped addressing, register 0 is accessed with --CE1 Low and --CE2 Low (and A0 Don't care) as a word register on the combined odd and even data bus (D15 to D0). This register may also be accessed with --CE1 Low and --CE2 High , by a pair of byte accesses to offset 0. The address space of this word register overlaps the address space of the error and feature bitwise registers at offset 1. When accessed twice as byte register with --CE1 Low , the first byte is the even byte of the word and the second is the odd byte. A byte access to register 0 with --CE1 High and --CE2 Low accesses the error (read) or feature (write) register.

Registers at offset 8, 9 and D are non-overlapping duplicates of the registers at offset 0 and 1. Register 8 is equivalent to register 0, while register 9 accesses the odd byte. Therefore, if the registers are byte accessed in the order 9 then 8 the data will be transferred odd byte then even byte. Repeated byte accesses to register 8 or 0 will access consecutive (even then odd) bytes from the data buffer. Repeated word accesses to register 8, 9 or 0 will access consecutive words from the data buffer, however repeated byte accesses to register 9 are not supported. Repeated alternating byte accesses to registers 8 then 9 will access consecutive (even then odd) bytes from the data buffer.

Table 37. Contiguous I/O decoding

--REG	A10 to A4	A3	A2	A1	A0	Offset	--IORD=0	--IOWR=0
0	X	0	0	0	0	0h	Even Data register	Even Data register
0	X	0	0	0	1	1h	Error register	Feature register
0	X	0	0	1	0	2h	Sector Count register	Sector Count register
0	X	0	0	1	1	3h	Sector Number register	Sector Number register
0	X	0	1	0	0	4h	Cylinder Low register	Cylinder Low register
0	X	0	1	0	1	5h	Cylinder High register	Cylinder High register
0	X	0	1	1	0	6h	Select Card/Head register	Select Card/Head register
0	X	0	1	1	1	7h	Status register	Command register
0	X	1	0	0	0	8h	Dup. Even Data register	Dup. Even Data register
0	X	1	0	0	1	9h	Dup. Odd Data register	Dup. Odd Data register
0	X	1	1	0	1	Dh	Dup. Error register	Dup. Feature register
0	X	1	1	1	0	Eh	Alternate Status register	Device Control register
0	X	1	1	1	1	Fh	Drive Address register	Reserved

7.4 I/O primary and secondary address configurations (conf = 2,3)

When the system decodes the primary and secondary address configurations, the registers are accessed in the block of I/O space as shown in [Table 38](#).

As for the memory mapped addressing, register 0 is accessed with –CE1 Low and –CE2 Low (and A0 Don't care) as a word register on the combined odd and even data bus (D15 to D0). This register may also be accessed with –CE1 Low and –CE2 High, by a pair of byte accesses to offset 0. The address space of this word register overlaps the address space of the error and feature bitwise registers at offset 1. When accessed twice as byte register with –CE1 Low, the first byte is the even byte of the word and the second is the odd byte. A byte access to register 0 with –CE1 High and –CE2 Low accesses the error (read) or feature (write) register.

Table 38. Primary and secondary I/O decoding

–REG	A9 to A4	A3	A2	A1	A0	–IORD=0	–IOWR=0
0	1F(17)h	0	0	0	0	Even Data register	Even Data register
0	1F(17)h	0	0	0	1	Error register	Feature register
0	1F(17)h	0	0	1	0	Sector Count register	Sector Count register
0	1F(17)h	0	0	1	1	Sector Number register	Sector Number register
0	1F(17)h	0	1	0	0	Cylinder Low register	Cylinder Low register
0	1F(17)h	0	1	0	1	Cylinder High register	Cylinder High register
0	1F(17)h	0	1	1	0	Select Card/Head register	Select Card/Head register
0	1F(17)h	0	1	1	1	Status register	Command register
0	3F(37)h	0	1	1	0	Alternate Status register	Device Control register
0	3F(37)h	0	1	1	1	Drive Address register	Reserved

7.5 True IDE mode addressing

When the card is configured in the True IDE mode, the I/O decoding is as shown in [Table 39](#).

Table 39. True IDE mode I/O decoding

-CE2	-CE1	A2	A1	A0	-IORD=0	-IOWR=0
1	0	0	0	0	Data register	Data register
1	0	0	0	1	Error register	Feature register
1	0	0	1	0	Sector Count register	Sector Count register
1	0	0	1	1	Sector Number register	Sector Number register
1	0	1	0	0	Cylinder Low register	Cylinder Low register
1	0	1	0	1	Cylinder High register	Cylinder High register
1	0	1	1	0	Select Card/Head register	Select Card/Head register
1	0	1	1	1	Status register	Command register
0	1	1	1	0	Alternate Status register	Device Control register
0	1	1	1	1	Drive Address	Reserved

8 CF-ATA registers

The following section describes the hardware registers used by the host software to issue commands to the card. These registers are collectively referred to as the 'task file'.

8.1 Data register (address 1F0h [170h]; offset 0, 8, 9)

The data register is a 16-bit register used to transfer data blocks between the card data buffer and the host. This register overlaps the error register. [Table 40](#) describes the combinations of data register access and explains the overlapped data and error/feature registers. Because of the overlapped registers, access to the 1F1h, 171h or offset 1 are not defined for word ($-CE2$ and $-CE1$ set to '0') operations, and are treated as accesses to the word data register. The duplicated registers at offsets 8, 9 and Dh have no restrictions on the operations that can be performed.

Table 40. Data register access

Data register	$-CE2$	$-CE1$	A0	Offset	Data Bus
Word Data register	0	0	X	0, 8, 9	D15 to D0
Even Data register	1	0	0	0, 8	D7 to D0
Odd Data register	1	0	1	9	D7 to D0
Odd Data register	0	1	X	8, 9	D15 to D8
Error/Feature register	1	0	1	1, Dh	D7 to D0
Error/Feature register	0	1	X	1	D15 to D8
Error/Feature register	0	0	X	Dh	D15 to D8

8.2 Error register (address 1F1h [171h]; offset 1, 0Dh read only)

This read only register contains additional information about the source of an error when an error is indicated in bit 0 of the status register. The bits are defined in [Table 41](#). This register is accessed on data bits D15 to D8 during a write operation to offset 0 with $-CE2$ Low and $-CE1$ High.

8.2.1 Bit 7 (BBK)

This bit is set when a bad block is detected.

8.2.2 Bit 6 (UNC)

This bit is set when an uncorrectable error is encountered.

8.2.3 Bit 5

This bit is '0'.

8.2.4 Bit 4 (IDNF)

This bit is set if the requested sector ID is in error or cannot be found.

8.2.5 Bit 3

This bit is '0'.

8.2.6 Bit 2 (abort)

This bit is set if the command has been aborted because of a card status condition (Not Ready, Write Fault, etc.) or when an invalid command has been issued.

8.2.7 Bit 1

This bit is '0'.

8.2.8 Bit 0 (AMNF)

This bit is set when there is a general error.

Table 41. Error register

D7	D6	D5	D4	D3	D2	D1	D0
BBK	UNC	0	IDNF	0	ABRT	0	AMNF

8.3 Feature register (address 1F1h [171h]; offset 1, 0Dh write only)

This write-only register provides information on features that the host can utilize. It is accessed on data bits D15 to D8 during a write operation to offset 0 with –CE2 Low and –CE1 High.

8.4 Sector Count register (address 1F2h [172h]; offset 2)

This register contains the number of sectors of data to be transferred on a read or write operation between the host and card. If the value in this register is zero, a count of 256 sectors is specified. If the command was successful, this register is zero at completion. If not successfully completed, the register contains the number of sectors that need to be transferred in order to complete the request. The default value is 01h.

8.5 Sector Number (LBA 7-0) register (address 1F3h [173h]; offset 3)

This register contains the starting sector number or bits 7 to 0 of the logical block address (LBA), for any data access for the subsequent sector transfer command.

8.6 Cylinder Low (LBA 15-8) register (address 1F4h [174h]; offset 4)

This register contains the least significant 8 bits of the starting cylinder address or bits 15 to 8 of the logical block address.

8.7 Cylinder High (LBA 23-16) register (address 1F5h [175h]; offset 5)

This register contains the most significant bits of the starting cylinder address or bits 23 to 16 of the logical block address.

8.8 Drive/Head (LBA 27-24) register (address 1F6h [176h]; offset 6)

The Drive/Head register is used to select the drive and head. It is also used to select LBA addressing instead of cylinder/head/sector addressing. The bits are defined in [Table 42](#).

8.8.1 Bit 7

This bit is set to '1'.

8.8.2 Bit 6 (LBA)

LBA is a flag to select either Cylinder/Head/Sector (CHS) or Logical Block Address mode (LBA). When LBA is set to '0', Cylinder/Head/Sector mode is selected. When LBA is set to '1', Logical Block Address mode is selected. In Logical Block Address mode, the logical block address is interpreted as follows:

- LBA7-LBA0: Sector Number register D7 to D0.
- LBA15-LBA8: Cylinder Low register D7 to D0.
- LBA23-LBA16: Cylinder High register D7 to D0.
- LBA27-LBA24: Drive/Head register bits HS3 to HS0.

8.8.3 Bit 5

This bit is set to '1'.

8.8.4 Bit 4 (DRV)

DRV is the drive number. When DRV is '0', drive/card 0 is selected (master). When DRV is '1', drive/card 1 is selected (slave). The card is set to card 0 or 1 using the copy field (Drive #) of the PCMCIA Socket & Copy configuration register.

8.8.5 Bit 3 (HS3)

When operating in the Cylinder, Head, Sector mode, this is bit 3 of the head number. It is bit 27 in the Logical Block Address mode.

8.8.6 Bit 2 (HS2)

When operating in the Cylinder, Head, Sector mode, this is bit 2 of the head number. It is bit 26 in the Logical Block Address mode.

8.8.7 Bit 1 (HS1)

When operating in the Cylinder, Head, Sector mode, this is bit 1 of the head number. It is bit 25 in the Logical Block Address mode.

8.8.8 Bit 0 (HS0)

When operating in the Cylinder, Head, Sector mode, this is bit 0 of the head number. It is bit 24 in the Logical Block Address mode.

Table 42. Drive/Head register

D7	D6	D5	D4	D3	D2	D1	D0
1	LBA	1	DRV	HS3	HS2	HS1	HS0

8.9 Status & alternate status registers (address 1F7h [177h] & 3F6h [376h]; offsets 7 & Eh)

These registers return the card status when read by the host.

Reading the status register clears a pending interrupt. Reading the auxiliary status register does not clear a pending interrupt.

The status register should be accessed in Byte mode; in Word mode it is recommended that alternate status register is used. The status bits are described as follows

8.9.1 Bit 7 (BUSY)

The busy bit is set when only the card can access the command register and buffer. The host is denied access. No other bits in this register are valid when this bit is set to '1'.

8.9.2 Bit 6 (RDY)

This bit indicates whether the device is capable of performing CompactFlash memory card operations. This bit is cleared at power-up and remains cleared until the card is ready to accept a command.

8.9.3 Bit 5 (DWF)

When set this bit indicates a write fault has occurred.

8.9.4 Bit 4 (DSC)

This bit is set when the card is ready.

8.9.5 Bit 3 (DRQ)

The data request is set when the card requires information be transferred either to or from the host through the data register. The bit is cleared by the next command.

8.9.6 Bit 2 (CORR)

This bit is set when a correctable data error has been encountered and the data has been corrected. This condition does not terminate a multi-sector read operation.

8.9.7 Bit 1 (IDX)

This bit is always set to '0'.

8.9.8 Bit 0 (ERR)

This bit is set when the previous command has ended in some type of error. The bits in the error register contain additional information describing the error. In case of read or write access commands that end with an error, the address of the first sector with an error is in the command block registers. This bit is cleared by the next command.

Table 43. Status & alternate status register

D7	D6	D5	D4	D3	D2	D1	D0
BUSY	RDY	DWF	DSC	DRQ	CORR	0	ERR

8.10 Device control register (address 3F6h [376h]; offset Eh)

This write-only register is used to control the CompactFlash memory card interrupt request and to issue an ATA soft reset to the card. This register can be written even if the device is BUSY. The bits are defined as follows:

8.10.1 Bit 7 to 3

Don't care. The host should reset this bit to '0'.

8.10.2 Bit 2 (SW Rst)

This bit is set to '1' in order to force the CompactFlash storage card to perform an AT Disk controller Soft Reset operation. This clears status register and writes diagnostic code in error register after a write or read sector error. The card remains in reset until this bit is reset to '0'.

8.10.3 Bit 1 (-IE_n)

When the Interrupt Enable bit is set to '0', -IREQ interrupts are enabled. When the bit is set to '1', interrupts from the card are disabled. This bit also controls the Int bit in the card configuration and status register. It is set to '0' at power-on.

8.10.4 Bit 0

This bit is set to '0'.

Table 44. Device control register

D7	D6	D5	D4	D3	D2	D1	D0
X(0)	X(0)	X(0)	X(0)	X(0)	SW Rst	-IE _n	0

8.11 Card (drive) address register (address 3f7h [377h]; offset Fh)

This read-only register is provided for compatibility with the AT disk drive interface and can be used for confirming the drive status. It is recommended that this register is not mapped into the host's I/O space because of potential conflicts on bit 7. The bits are defined as follows:

8.11.1 Bit 7

This bit is Don't care.

8.11.2 Bit 6 (–WTG)

This bit is '0' when a write operation is in progress, otherwise, it is '1'.

8.11.3 Bit 5 (–HS3)

This bit is the negation of bit 3 in the drive/head register.

8.11.4 Bit 4 (–HS2)

This bit is the negation of bit 2 in the drive/head register.

8.11.5 Bit 3 (–HS1)

This bit is the negation of bit 1 in the drive/head register.

8.11.6 Bit 2 (–HS0)

This bit is the negation of bit 0 in the drive/head register.

8.11.7 Bit 1 (–nDS1)

This bit is '0' when drive 1 is active and selected.

8.11.8 Bit 0 (–nDS0)

This bit is '0' when the drive 0 is active and selected.

Table 45. Card (drive) address register

D7	D6	D5	D4	D3	D2	D1	D0
X	–WTG	–HS3	–HS2	–HS1	–HS0	–nDS1	–nDS0

9 CF-ATA command description

This section defines the software requirements and the format of the commands the host sends to the card. Commands are issued to the card by loading the required registers in the command block with the supplied parameters, and then writing the command code to the command register. There are three classes of command acceptance, all dependent on the host not issuing commands unless the card is not busy (BSY is '0').

- **Class 1.** Upon receipt of a class 1 command, the card sets BSY within 400 ns.
- **Class 2.** Upon receipt of a class 2 command, the card sets BSY within 400 ns, sets up the sector buffer for a write operation, sets DRQ within 700 μ s, and clears BSY within 400 ns of setting DRQ.
- **Class 3.** Upon receipt of a class 3 command, the card sets BSY within 400 ns, sets up the sector buffer for a write operation, sets DRQ within 20 ms (assuming no re-assignments), and clears BSY within 400 ns of setting DRQ.

For reasons of backward compatibility some commands are implemented as 'no operation' NOP.

[Table 46](#) summarizes the CF-ATA command set with the paragraphs that follow describing the individual commands and the task file for each.

Table 46. CF-ATA command set⁽¹⁾

Class	Command	Code	FR	SC	SN	CY	DH	LBA
1	Check Power mode	E5h or 98h					D	
1	Execute Drive Diagnostic	90h					YD	
1	Erase Sector(s)	C0h		Y	Y	Y	Y	Y
1	Identify Drive	ECh					D	
1	Idle	E3h or 97h		Y			D	
1	Idle immediate	E1h or 95h					D	
1	Initialize Drive Parameters	91h		Y			Y	
1	NOP	00h					D	
1	Read Buffer	E4h					D	
1	Read Multiple	C4h		Y	Y	Y	Y	Y
1	Read Sector(s)	20h or 21h		Y	Y	Y	Y	Y
1	Read Verify Sector(s)	40h or 41h		Y	Y	Y	Y	Y
1	Recalibrate	1Xh					D	
1	Request Sense	03h					D	
1	Seek	7Xh			Y	Y	Y	Y
1	Set Features	EFh	Y				D	
1	Set Multiple mode	C6h		Y			D	
1	Set Sleep mode	E6h or 99h					D	
1	Standby	E2h or 96h					D	

Table 46. CF-ATA command set⁽¹⁾ (continued)

Class	Command	Code	FR	SC	SN	CY	DH	LBA
1	Standby immediate	E0h or 94h					D	
1	Translate Sector	87h		Y	Y	Y	Y	Y
1	Wear Level	F5h					Y	
2	Write Buffer	E8h					D	
3	Write Multiple	C5h		Y	Y	Y	Y	Y
3	Write Multiple w/o Erase	CDh		Y	Y	Y	Y	Y
2	Write Sector(s)	30h or 31h		Y	Y	Y	Y	Y
2	Write Sector(s) w/o Erase	38h		Y	Y	Y	Y	Y
3	Write Verify	3Ch		Y	Y	Y	Y	Y

- FR = Features Register, SC = Sector Count Register, SN = Sector Number Register, CY = Cylinder Registers, DH = Card/Drive/Head Register, LBA = Logical Block Address Mode Supported (see command descriptions for use),
 Y - The register contains a valid parameter for this command. For the drive/head register Y means both the Compact Flash memory card and head parameters are used.
 D - only the Compact Flash memory card parameter is valid and not the head parameter
 C - the register contains command specific data (see command descriptors for use).

9.1 Check Power mode command (98h or E5h)

This command checks the power mode.

Issuing the command while the card is in Standby mode, is about to enter Standby, or is exiting Standby, the command will set BSY, set the Sector Count register to 00h, clear BSY and generate an interrupt.

Issuing the command when the card is in Idle mode will set BSY, set the Sector Count register to FFh, clear BSY and generate an interrupt.

[Table 47](#) defines the byte sequence of the Check Power mode command.

Table 47. Check Power mode

Bit	7	6	5	4	3	2	1	0	
Command (7)	98h or E5h								
C/D/H (6)	X			Drive	X				
Cyl High (5)					X				
Cyl Low (4)					X				
Sect Num (3)					X				
Sect Cnt (2)					X				
Feature (1)					X				

9.2 Execute Drive Diagnostic command (90h)

This command performs the internal diagnostic tests implemented by the card.

In PCMCIA configuration, this command only runs on the card which is addressed by the drive/head register when the command is issued. This is because PCMCIA card interface does not allow for direct inter-drive communication.

In True IDE mode, the Drive bit is ignored and the diagnostic command is executed by both the master and the slave with the master responding with the status for both devices.

[Table 48](#) defines the Execute Drive Diagnostic command byte sequence. The diagnostic codes shown in [Table 49](#) are returned in the error register at the end of the command.

Table 48. Execute Drive Diagnostic

Bit	7	6	5	4	3	2	1	0
Command (7)	90h							
C/D/H (6)	X		Drive		X			
Cyl High (5)					X			
Cyl Low (4)					X			
Sect Num (3)					X			
Sect Cnt (2)					X			
Feature (1)					X			

Table 49. Diagnostic codes

Code	Error type
01h	No error detected
02h	Formatter device error
03h	Sector buffer error
04h	ECC circuitry error
05h	Controlling microprocessor error
8Xh	Slave error in True IDE mode

9.3 Erase Sector(s) command (C0h)

This command is used to pre-erase and condition data sectors prior to a Write Sector Without Erase command or a Write Multiple Without Erase command. There is no data transfer associated with this command but a Write Fault error status can occur. [Table 50](#) defines the byte sequence of the Erase Sector command.

Table 50. Erase Sector(s)

Bit	7	6	5	4	3	2	1	0
Command (7)	C0h							
C/D/H (6)	1	LBA	1	Drive	Head (LBA 27-24)			
Cyl High (5)	Cylinder High (LBA 23-16)							
Cyl Low (4)	Cylinder Low (LBA 15-8)							
Sect Num (3)	Sector Number (LBA 7-0)							
Sect Cnt (2)	Sector Count							
Feature (1)	X							

9.4 Identify Drive command (ECh)

The Identify Drive command enables the host to receive parameter information from the card. This command has the same protocol as the Read Sector(s) command. [Table 51](#) defines the Identify Drive command byte sequence. All reserved bits or words are zero. [Table 52](#) shows the definition of each field in the identify drive information.

9.4.1 Word 0: general configuration

This field indicates that the device is a CompactFlash memory card.

9.4.2 Word 1: default number of cylinders

This field contains the number of translated cylinders in the default translation mode. This value will be the same as the number of cylinders.

9.4.3 Word 3: default number of heads

This field contains the number of translated heads in the default translation mode.

9.4.4 Word 6: default number of sectors per track

This field contains the number of sectors per track in the default translation mode.

9.4.5 Word 7-8: number of sectors per card

This field contains the number of sectors per card. This double word value is also the first invalid address in LBA translation mode.

9.4.6 Word 10-19: memory card serial number

The contents of this field are right justified and padded with spaces (20h).

9.4.7 Word 23-26: firmware revision

This field contains the revision of the firmware for this product.

9.4.8 Word 27-46: model number

This field contains the model number for this product and is left justified and padded with spaces (20h).

9.4.9 Word 47: read/write multiple sector count

This field contains the maximum number of sectors that can be read or written per interrupt using the Read Multiple or Write Multiple commands.

9.4.10 Word 49: capabilities

- Bit 13 Standby timer: it is set to '0' to indicate that the Standby timer operation is defined by the manufacturer.
- Bit 9 LBA support: CompactFlash memory cards support LBA mode addressing.
- Bit 8 DMA Support: DMA mode is not supported.

9.4.11 Word 51: PIO data transfer cycle timing mode

This field defines the mode for PIO data transfer. For backward compatibility with BIOSs written before word 64 was defined for advanced modes, a device reports in word 51, the highest original PIO mode it can support (PIO mode 0, 1 or 2).

Bits 15-8: are set to 02H.

9.4.12 Word 53: translation parameter valid

- Bit 1: is set to '1' to indicate that words 64 to 70 are valid
- Bit 0: is set to '1' to indicate that words 54 to 58 are valid

9.4.13 Word 54-56: current number of cylinders, heads, sectors/track

These fields contains the current number of user addressable cylinders, heads, and sectors/track in the current translation mode.

9.4.14 Word 57-58: current capacity

This field contains the product of the current cylinders, heads and sectors.

9.4.15 Word 59: multiple sector setting

- Bits 15-9 are reserved and must be set to '0'.
- Bit 8 is set to '1', to indicate that the multiple sector setting is valid.
- Bits 7-0 are the current setting for the number of sectors to be transferred for every interrupt, on Read/Write Multiple commands; the only values returned are 00h or 01h.

9.4.16 Word 60-61: total sectors addressable in LBA mode

This field contains the number of sectors addressable for the card in LBA mode only.

9.4.17 Word 64: advanced PIO transfer modes supported

This field is bit significant. Any number of bits may be set to '1' in this field by the CompactFlash memory card to indicate the advanced PIO modes it is capable of supporting.

- Bits 7-2 are reserved for future advanced PIO modes.
- Bit 1 is set to '1', indicates that the CompactFlash memory card supports PIO mode 4.
- Bit 0 is set to '1' to indicate that the CompactFlash memory card supports PIO mode 3.

9.4.18 Word 67: minimum PIO transfer cycle time without flow control

This field gives the minimum cycle time (in ns) that the host should use for the CompactFlash memory card to provide data integrity during transfer when flow control is not used. The value returned is 78h (for cycle time values refer to [Table 22](#)).

9.4.19 Word 68: minimum PIO transfer cycle time with IORDY

This field gives the minimum cycle time (in ns) supported by the CompactFlash memory card to perform data transfers using IORDY flow control. The value returned is 78h (for cycle time values refer to [Table 22](#)).

Table 51. Identify drive

Bit	7	6	5	4	3	2	1	0
Command (7)	ECh							
C/D/H (6)	X			Drive	X			
Cyl High (5)					X			
Cyl Low (4)					X			
Sect Num (3)					X			
Sect Cnt (2)					X			
Feature (1)					X			

Table 52. Identify drive information

Word address	Default value	Total bytes	Data field type information
0	848Ah	2	General configuration (signature for the CompactFlash memory card)
1	XXXXh	2	Default number of cylinders
2	0000h	2	Reserved
3	00XXh	2	Default number of heads
4	0000h	2	Obsolete
5	0000h	2	Obsolete
6	XXXXh	2	Default number of sectors per track
7-8	XXXXh	4	Number of sectors per card (word 7 = MSW, word 8 = LSW)
9	0000h	2	Obsolete
10-19	aaaa	20	Serial number in ASCII (right justified)
20	0000h	2	Obsolete
21	0000h	2	Obsolete
22	0004h	2	Reserved
23-26	aaaa	8	Firmware revision in ASCII. Big endian byte order in word
27-46	aaaa	40	Model number in ASCII (right justified) big endian byte order in word
47	0001h	2	Maximum number of sectors on read/write multiple command
48	0000h	2	Reserved
49	0200h	2	Capabilities
50	0000h	2	Reserved
51	0200h	2	PIO data transfer cycle timing mode
52	0000h	2	Obsolete
53	0003h	2	Field validity
54	XXXXh	2	Current numbers of cylinders
55	XXXXh	2	Current numbers of heads
56	XXXXh	2	Current sectors per track
57-58	XXXXh	4	Current capacity in sectors (LBAs) (word 57 = LSW, word 58 = MSW)
59	01XXh	2	Multiple sector setting
60-61	XXXXh	4	Total number of sectors addressable in LBA mode
62-63	0000h	4	Reserved
64	0003h	2	Advanced PIO modes supported
65-66	0000h	4	Reserved
67	0078h	2	Minimum PIO transfer cycle time without flow control
68	0078h	2	Minimum PIO transfer cycle time with IORDY flow control
69-128	0000h	120	Reserved
129-159	0000h	62	Manufacturer unique bytes
160-255	0000h	192	Reserved

9.5 Idle command (97h or E3h)

This command causes the card to set BSY, enter the Idle mode, clear BSY and generate an interrupt. If the sector count is non-zero, it is interpreted as a timer count (each count is 5 ms) and the automatic power down mode is enabled. If the sector count is zero, the automatic power-down mode is disabled. Note that this time base (5 ms) is different from the ATA specification. [Table 53](#) defines the byte sequence of the Idle command.

Table 53. Idle

Bit	7	6	5	4	3	2	1	0
Command (7)	97h or E3h							
C/D/H (6)	X			Drive	X			
Cyl High (5)					X			
Cyl Low (4)					X			
Sect Num (3)					X			
Sect Cnt (2)	Timer Count (5 ms increments)							
Feature (1)					X			

9.6 Idle Immediate command (95h or E1h)

This command causes the card to set BSY, enter the Idle mode, clear BSY and generate an interrupt. [Table 54](#) defines the Idle Immediate command byte sequence.

Table 54. Idle Immediate

Bit	7	6	5	4	3	2	1	0
Command (7)	95h or E1h							
C/D/H (6)	X			Drive	X			
Cyl High (5)					X			
Cyl Low (4)					X			
Sect Num (3)					X			
Sect Cnt (2)					X			
Feature (1)					X			

9.7 Initialize Drive Parameters command (91h)

This command enables the host to set the number of sectors per track and the number of heads per cylinder. Only the Sector Count and the Card/Drive/Head registers are used by this command. [Table 55](#) defines the Initialize Drive Parameters command byte sequence.

Table 55. Initialize Drive Parameters

Bit	7	6	5	4	3	2	1	0
Command (7)	91h							
C/D/H (6)	X	0	X	Drive	Max Head (no. of heads 1)			
Cyl High (5)					X			
Cyl Low (4)					X			
Sect Num (3)					X			
Sect Cnt (2)					Number of sectors			
Feature (1)					X			

9.8 NOP command (00h)

This command always fails with the CompactFlash memory card returning command aborted. [Table 56](#) defines the byte sequence of the NOP command.

Table 56. NOP

Bit	7	6	5	4	3	2	1	0
Command (7)	00h							
C/D/H (6)	X			Drive	X			
Cyl High (5)					X			
Cyl Low (4)					X			
Sect Num (3)					X			
Sect Cnt (2)					X			
Feature (1)					X			

9.9 Read Buffer command (E4h)

The Read Buffer command enables the host to read the current contents of the card's sector buffer. This command has the same protocol as the Read Sector(s) command. [Table 57](#) defines the Read Buffer command byte sequence.

Table 57. Read Buffer

Bit	7	6	5	4	3	2	1	0
Command (7)	E4h							
C/D/H (6)	X			Drive	X			
Cyl High (5)					X			
Cyl Low (4)					X			
Sect Num (3)					X			
Sect Cnt (2)					X			
Feature (1)					X			

9.10 Read Multiple command (C4h)

The Read Multiple command performs similarly to the Read Sectors command. Interrupts are not generated on every sector, but on the transfer of a block which contains the number of sectors defined by a Set Multiple command.

Command execution is identical to the Read Sectors operation except that the number of sectors defined by a Set Multiple command are transferred without intervening interrupts. DRQ qualification of the transfer is required only at the start of the data block, not on each sector.

The block count of sectors to be transferred without intervening interrupts is programmed by the Set Multiple mode command, which must be executed prior to the Read Multiple command. When the Read Multiple command is issued, the Sector Count register contains the number of sectors (not the number of blocks or the block count) requested. If the number of requested sectors is not evenly divisible by the block count, as many full blocks as possible are transferred, followed by a final, partial block transfer. The partial block transfer is for n sectors, where:

$$n = (\text{sector count}) \text{ module } (\text{block count}).$$

If the Read Multiple command is attempted before the Set Multiple mode command has been executed or when Read Multiple commands are disabled, the Read Multiple operation is rejected with an aborted command error. Disk errors encountered during Read Multiple commands are posted at the beginning of the block or partial block transfer, but DRQ is still set and the data transfer will take place as it normally would, including transfer of corrupted data, if any.

Interrupts are generated when DRQ is set at the beginning of each block or partial block. The error reporting is the same as that on a Read Sector(s) command. This command reads from 1 to 256 sectors as specified in the Sector Count register. A sector count of 0 requests 256 sectors. The transfer begins at the sector specified in the Sector Number register.

If an error occurs, the read terminates at the sector where the error occurred. The Command Block registers contain the cylinder, head and sector number of the sector where the error occurred. The flawed data is pending in the sector buffer.

Subsequent blocks or partial blocks are transferred only if the error was a correctable data error. All other errors cause the command to stop after transfer of the block which contained the error.

[Table 58](#) defines the Read Multiple command byte sequence.

Table 58. Read Multiple

Bit	7	6	5	4	3	2	1	0
Command (7)	C4h							
C/D/H (6)	1	LBA	1	Drive	Head (LBA 27-24)			
Cyl High (5)	Cylinder High (LBA 23-16)							
Cyl Low (4)	Cylinder Low (LBA 15-8)							
Sect Num (3)	Sector Number (LBA 7-0)							
Sect Cnt (2)	Sector Count							
Feature (1)	X							

9.11 Read Sector(s) command (20h or 21h)

This command reads from 1 to 256 sectors as specified in the Sector Count register. A sector count of 0 requests 256 sectors. The transfer begins at the sector specified in the Sector Number register. When this command is issued and after each sector of data (except the last one) has been read by the host, the card sets BSY, puts the sector of data in the buffer, sets DRQ, clears BSY, and generates an interrupt. The host then reads the 512 bytes of data from the buffer.

If an error occurs, the read terminates at the sector where the error occurred. The Command Block registers contain the cylinder, head, and sector number of the sector where the error occurred. The flawed data is pending in the sector buffer. [Table 59](#) defines the Read Sector command byte sequence.

Table 59. Read Sector(s)

Bit	7	6	5	4	3	2	1	0
Command (7)	20h or 21h							
C/D/H (6)	1	LBA	1	Drive	Head (LBA 27-24)			
Cyl High (5)	Cylinder High (LBA 23-16)							
Cyl Low (4)	Cylinder Low (LBA 15-8)							
Sect Num (3)	Sector Number (LBA 7-0)							
Sect Cnt (2)	Sector Count							
Feature (1)	X							

9.12 Read Verify Sector(s) command (40h or 41h)

This command is identical to the Read Sectors command, except that DRQ is never set and no data is transferred to the host. When the command is accepted, the card sets BSY. When the requested sectors have been verified, the card clears BSY and generates an interrupt.

If an error occurs, the verify terminates at the sector where the error occurs. The Command Block registers contain the cylinder, head and sector number of the sector where the error occurred. The Sector Count register contains the number of sectors not yet verified.

[Table 60](#) defines the Read Verify Sector command byte sequence.

Table 60. Read Verify Sector(s)

Bit	7	6	5	4	3	2	1	0
Command (7)	40h or 41h							
C/D/H (6)	1	LBA	1	Drive	Head (LBA 27-24)			
Cyl High (5)	Cylinder High (LBA 23-16)							
Cyl Low (4)	Cylinder Low (LBA 15-8)							
Sect Num (3)	Sector Number (LBA 7-0)							
Sect Cnt (2)	Sector Count							
Feature (1)	X							

9.13 Recalibrate command (1Xh)

This command is effectively a NOP command to the card and is provided for compatibility purposes. [Table 61](#) defines the Recalibrate command byte sequence.

Table 61. Recalibrate

Bit	7	6	5	4	3	2	1	0
Command (7)	1Xh							
C/D/H (6)	1	LBA	1	Drive	X			
Cyl High (5)	X							
Cyl Low (4)	X							
Sect Num (3)	X							
Sect Cnt (2)	X							
Feature (1)	X							

9.14 Request Sense command (03h)

This command requests extended error information for the previous command. [Table 62](#) defines the Request Sense command byte sequence. [Table 63](#) defines the valid extended error codes. The extended error code is returned to the host in the Error register.

Table 62. Request Sense

Bit	7	6	5	4	3	2	1	0
Command (7)	03h							
C/D/H (6)	1	X	1	Drive	X			
Cyl High (5)					X			
Cyl Low (4)					X			
Sect Num (3)					X			
Sect Cnt (2)					X			
Feature (1)					X			

Table 63. Extended Error codes

Extended error code	Description
00h	No error detected
01h	Self test OK (no error)
09h	Miscellaneous error
21h	Invalid address (requested head or sector invalid)
2Fh	Address overflow (address too large)
35h, 36h	Supply or generated voltage out of tolerance
11h	Uncorrectable ECC Error
18h	Corrected ECC Error
05h, 30-34h, 37h, 3Eh	Self test or diagnostic failed
10h, 14h	ID not found
3Ah	Spare sectors exhausted
1Fh	Data transfer error / aborted command
0Ch, 38h, 3Bh, 3Ch, 3Fh	Corrupted media format
03h	Write / Erase failed

9.15 Seek command (7Xh)

This command is effectively a NOP command to the card although it does perform a range check of cylinder and head or LBA address and returns an error if the address is out of range. [Table 64](#) shows the Seek command byte sequence.

Table 64. Seek

Bit	7	6	5	4	3	2	1	0
Command (7)	7Xh							
C/D/H (6)	1	LBA	1	Drive	Head (LBA 27-24)			
Cyl High (5)	Cylinder High (LBA 23-16)							
Cyl Low (4)	Cylinder Low (LBA 15-8)							
Sect Num (3)	X (LBA 7-0)							
Sect Cnt (2)	X							
Feature (1)	X							

9.16 Set Features command (EFh)

This command is used by the host to establish or select certain features. [Table 65](#) shows the Set Features command byte sequence. [Table 66](#) defines all features that are supported.

Features 01h and 81h are used to enable and clear 8 bit data transfer modes in True IDE mode. If the 01h Feature command is issued all data transfers will occur on the low order D7D0 data bus and the -IOIS16 signal will not be asserted for data register accesses.

Feature 03h allows the host to select the PIO transfer mode by specifying a value in the Sector Count register (see [Table 67](#) for values). The upper 5 bits define the type of transfer and the low order 3 bits encode the mode value. One PIO mode should be selected at all times. The host may change the selected mode by issuing the Set Features command.

Feature code 9Ah enables the host to configure the card to best meet the host system's power requirements. The host sets a value in the Sector Count register that is equal to one-fourth of the desired maximum average current (in mA) that the card should consume. For example, if the Sector Count register were set to 6, the card would be configured to provide the best possible performance without exceeding 24 mA. Upon completion of the command, the card responds to the host with the range of values supported by the card. The minimum value is set in the Cylinder Low register, and the maximum value is set in the Cylinder Hi register. The default value, after a power on reset, is to operate at the highest performance and therefore the highest current mode.

The card will accept values outside this programmable range, but will operate at either the lowest power or highest performance as appropriate.

Table 65. Set Features

Bit	7	6	5	4	3	2	1	0
Command (7)	EFh							
C/D/H (6)	X		Drive		X			
Cyl High (5)					X			
Cyl Low (4)					X			
Sect Num (3)					X			
Sect Cnt (2)					Config			
Feature (1)					Feature			

Table 66. Features supported

Feature	Operation
01h	Enable 8 bit data transfers.
03h	Set transfer mode based on value in Sector Count register.
55h	Disable Read Look Ahead.
69h	NOP Accepted for backward compatibility.
81h	Disable 8 bit data transfer.
96h	NOP accepted for backward compatibility.
97h	Accepted for backward compatibility. Use of this feature is not recommended.
9Ah	Set the host current source capability. Allows trade-off between current drawn and read/write speed.

Table 67. Transfer mode values

Mode	Bits (7:3)	Bits (2:0)
PIO default mode	00000b	000b
PIO default mode, disable IORDY	00000b	001b
PIO flow control transfer mode	00001b	Mode ⁽¹⁾

1. Mode = transfer mode number.

9.17 Set Multiple mode command (C6h)

This command enables the card to perform Read and Write Multiple operations and establishes the block count for these commands. The Sector Count register is loaded with the number of sectors per block. Upon receipt of the command, the card sets BSY and checks the Sector Count register.

If the Sector Count register contains a valid value and the block count is supported, the value is loaded for all subsequent Read Multiple and Write Multiple commands and execution is enabled. If a block count is not supported, an aborted command error is posted, and Read Multiple and Write Multiple commands are disabled. If the Sector Count register contains '0' when the command is issued, Read and Write Multiple commands are disabled. At power-on the default mode is Read and Write Multiple disabled, unless it is disabled by a Set Feature command. [Table 68](#) defines the Set Multiple Mode command byte sequence.

Table 68. Set Multiple mode

Bit	7	6	5	4	3	2	1	0
Command (7)	C6h							
C/D/H (6)	X			Drive	X			
Cyl High (5)	X							
Cyl Low (4)	X							
Sect Num (3)	X							
Sect Cnt (2)	Sector Count							
Feature (1)	X							

9.18 Set Sleep mode command (99h or E6h)

This command causes the CompactFlash memory card to set BSY, enter the Sleep mode, clear BSY and generate an interrupt. Recovery from sleep mode is accomplished by simply issuing another command. Sleep mode is also entered when internal timers expire so the host does not need to issue this command except when it wishes to enter Sleep mode immediately. The default value for the timer is 5 milliseconds. Note that this time base (5 ms) is different from the ATA specification. [Table 69](#) defines the Set Sleep mode command byte sequence.

Table 69. Set Sleep mode

Bit	7	6	5	4	3	2	1	0
Command (7)	99h or E6h							
C/D/H (6)	X			Drive	X			
Cyl High (5)	X							
Cyl Low (4)	X							
Sect Num (3)	X							
Sect Cnt (2)	X							
Feature (1)	X							

9.19 Standby command (96h or E2)

This command causes the card to set BSY, enter the Sleep mode (which corresponds to the ATA 'Standby' mode), clear BSY and return the interrupt immediately. Recovery from Sleep mode is accomplished by issuing another command. [Table 70](#) defines the Standby command byte sequence.

Table 70. Standby

Bit	7	6	5	4	3	2	1	0
Command (7)	96h or E2h							
C/D/H (6)	X			Drive	X			
Cyl High (5)					X			
Cyl Low (4)					X			
Sect Num (3)					X			
Sect Cnt (2)					X			
Feature (1)					X			

9.20 Standby Immediate command (94h or E0h)

This command causes the card to set BSY, enter the Sleep mode (which corresponds to the ATA Standby mode), clear BSY and return the interrupt immediately.

Recovery from Sleep mode is accomplished by issuing another command. [Table 71](#) defines the Standby Immediate byte sequence.

Table 71. Standby Immediate

Bit	7	6	5	4	3	2	1	0
Command (7)	94h or E0h							
C/D/H (6)	X			Drive	X			
Cyl High (5)					X			
Cyl Low (4)					X			
Sect Num (3)					X			
Sect Cnt (2)					X			
Feature (1)					X			

9.21 Translate Sector command (87h)

This command allows the host a method of determining the exact number of times a user sector has been erased and programmed. The controller responds with a 512-byte buffer of information containing the desired cylinder, head and sector, including its logical address, and the hot count, if available, for that sector. [Table 72](#) defines the Translate Sector command byte sequence. [Table 73](#) represents the information in the buffer.

Table 72. Translate Sector

Bit	7	6	5	4	3	2	1	0
Command (7)	87h							
C/D/H (6)	1	LBA	1	Drive	Head (LBA 27-24)			
Cyl High (5)	Cylinder High (LBA 23-16)							
Cyl Low (4)	Cylinder Low (LBA 15-8)							
Sect Num (3)	Sector Number (LBA 7-0)							
Sect Cnt (2)	X							
Feature (1)	X							

Table 73. Translate Sector information

Address	Information
00h-01h	Cylinder MSB (00), Cylinder LSB (01)
02h	Head
03h	Sector
04-06h	LBA MSB (04) - LSB (06)
07-12h	Reserved
13h	Erased Flag (FFh) = Erased; 00h = Not Erased
14h-17h	Reserved
18h-1Ah	Hot Count MSB (18) - LSB (1A); 0 = Hot Count not supported
1Bh-1FFh	Reserved

9.22 Wear Level command (F5h)

This command is effectively a NOP command and only implemented for backward compatibility. The Sector Count register will always be returned with a 00h indicating Wear Level is not needed.

[Table 74](#) defines the Wear Level command byte sequence.

Table 74. Wear Level

Bit	7	6	5	4	3	2	1	0
Command (7)	F5h							
C/D/H (6)	X			Drive	Flag			
Cyl High (5)					X			
Cyl Low (4)					X			
Sect Num (3)					X			
Sect Cnt (2)	Completion Status							
Feature (1)					X			

9.23 Write Buffer command (E8h)

The Write Buffer command enables the host to overwrite contents of the card's sector buffer with any data pattern desired. This command has the same protocol as the Write Sector(s) command and transfers 512 bytes.

[Table 75](#) defines the Write Buffer command byte sequence.

Table 75. Write Buffer

Bit	7	6	5	4	3	2	1	0
Command (7)	E8h							
C/D/H (6)	X			Drive	X			
Cyl High (5)					X			
Cyl Low (4)					X			
Sect Num (3)					X			
Sect Cnt (2)					X			
Feature (1)					X			

9.24 Write Multiple command (C5h)

This command is similar to the Write Sectors command. The card sets BSY within 400 ns of accepting the command. Interrupts are not presented on each sector but on the transfer of a block which contains the number of sectors defined by Set Multiple. Command execution is identical to the Write Sectors operation except that the number of sectors defined by the Set Multiple command is transferred without intervening interrupts.

DRQ qualification of the transfer is required only at the start of the data block, not on each sector. The block count of sectors to be transferred without intervening interrupts is programmed by the Set Multiple Mode command, which must be executed prior to the Write Multiple command.

When the Write Multiple command is issued, the Sector Count register contains the number of sectors (not the number of blocks or the block count) requested. If the number of requested sectors is not evenly divisible by the sector/block, as many full blocks as possible are transferred, followed by a final, partial block transfer. The partial block transfer is for n sectors, where:

$$n = (\text{sector count}) \text{ module } (\text{block count}).$$

If the Write Multiple command is attempted before the Set Multiple Mode command has been executed or when Write Multiple commands are disabled, the Write Multiple operation will be rejected with an aborted command error.

Errors encountered during Write Multiple commands are posted after the attempted writes of the block or partial block transferred. The Write command ends with the sector in error, even if it is in the middle of a block. Subsequent blocks are not transferred in the event of an error. Interrupts are generated when DRQ is set at the beginning of each block or partial block.

The Command Block registers contain the cylinder, head and sector number of the sector where the error occurred and the Sector Count register contains the residual number of sectors that need to be transferred for successful completion of the command. For example, each block has 4 sectors, a request for 8 sectors is issued and an error occurs on the third sector. The Sector Count register contains 6 and the address is that of the third sector.

Note: The current revision of the CompactFlash memory card only supports a block count of 1 as indicated in the Identify Drive command information. The Write Multiple command is provided for compatibility with future products which may support a larger block count.

[Table 76](#) defines the Write Multiple command byte sequence.

Table 76. Write Multiple

Bit	7	6	5	4	3	2	1	0
Command (7)	C5h							
C/D/H (6)	1	LBA	1	Drive	Head			
Cyl High (5)	Cylinder High							
Cyl Low (4)	Cylinder Low							
Sect Num (3)	Sector Number							
Sect Cnt (2)	Sector Count							
Feature (1)	X							

9.25 Write Multiple without Erase command (CDh)

This command is similar to the Write Multiple command with the exception that an implied erase before write operation is not performed. The sectors should be pre-erased with the Erase Sector(s) command before this command is issued. [Table 77](#) defines the Write Multiple without Erase command byte sequence.

Table 77. Write Multiple without Erase

Bit	7	6	5	4	3	2	1	0
Command (7)	CDh							
C/D/H (6)	X	LBA	1	Drive	Head			
Cyl High (5)	Cylinder High							
Cyl Low (4)	Cylinder Low							
Sect Num (3)	Sector Number							
Sect Cnt (2)	Sector Count							
Feature (1)	X							

9.26 Write Sector(s) command (30h or 31h)

This command writes from 1 to 256 sectors as specified in the Sector Count register. A sector count of zero requests 256 sectors. The transfer begins at the sector specified in the Sector Number register. When this command is accepted, the Card sets BSY, sets DRQ and clears BSY, then waits for the host to fill the sector buffer with the data to be written. No interrupt is generated to start the first host transfer operation. No data should be transferred by the host until BSY has been cleared by the host.

For multiple sectors, after the first sector of data is in the buffer, BSY will be set and DRQ will be cleared. After the next buffer is ready for data, BSY is cleared, DRQ is set and an interrupt is generated. When the final sector of data is transferred, BSY is set and DRQ is cleared. It will remain in this state until the command is completed at which time BSY is cleared and an interrupt is generated. If an error occurs during a write of more than one sector, writing terminates at the sector where the error occurred. The Command Block registers contain the cylinder, head and sector number of the sector where the error occurred. The host may then read the command block to determine what error has occurred, and on which sector. [Table 78](#) defines the Write Sector(s) command byte sequence.

Table 78. Write Sector(s)

Bit	7	6	5	4	3	2	1	0
Command (7)	30h or 31h							
C/D/H (6)	1	LBA	1	Drive	Head (LBA 27-24)			
Cyl High (5)	Cylinder High (LBA 23-16)							
Cyl Low (4)	Cylinder Low (LBA 15-8)							
Sect Num (3)	Sector Number (LBA 7-0)							
Sect Cnt (2)	Sector Count							
Feature (1)	X							

9.27 Write Sector(s) without Erase command (38h)

This command is similar to the Write Sector(s) command with the exception that an implied erase before write operation is not performed. This command has the same protocol as the Write Sector(s) command. The sectors should be pre-erased with the Erase Sector(s) command before this command is issued. If the sector is not pre-erased a normal write sector operation will occur. [Table 79](#) defines the Write Sector(s) without Erase command byte sequence.

Table 79. Write Sector(s) without Erase

Bit	7	6	5	4	3	2	1	0
Command (7)	38h							
C/D/H (6)	1	LB A	1	Drive	Head (LBA 27-24)			
Cyl High (5)	Cylinder High (LBA 23-16)							
Cyl Low (4)	Cylinder Low (LBA 15-8)							
Sect Num (3)	Sector Number (LBA 7-0)							
Sect Cnt (2)	Sector Count							
Feature (1)	X							

9.28 Write Verify command (3Ch)

This command is similar to the Write Sector(s) command, except each sector is verified immediately after being written. This command has the same protocol as the Write Sector(s) command. [Table 80](#) defines the Write Verify command byte sequence.

Table 80. Write Verify

Bit	7	6	5	4	3	2	1	0
Command (7)	3Ch							
C/D/H (6)	1	LBA	1	Drive	Head (LBA 27-24)			
Cyl High (5)	Cylinder High (LBA 23-16)							
Cyl Low (4)	Cylinder Low (LBA 15-8)							
Sect Num (3)	Sector Number (LBA 7-0)							
Sect Cnt (2)	Sector Count							
Feature (1)	X							

10 CIS information (typical)

0000: Code 01, link 04
DF 79 01 FF

- Tuple CISTPL_DEVICE (01), length 4 (04)
- Device type is FUNCSPEC
- Extended speed byte used
- Device speed is 80 ns
- Write protect switch is not in control
- Device size is 2 Kbytes

000C: Code 1C, link 05
02 DF 79 01 FF

- Tuple CISTPL_DEVICE_OC (1C), length 5 (05)
- Device conditions: $V_{CC} = 3.3\text{ V}$
- Device type is FUNCSPEC
- Extended speed byte used
- Device speed is 80 ns
- Write protect switch is not in control
- Device size is 2 Kbytes

001A: Code 18, link 02
DF 01

- Tuple CISTPL_JEDEC_C (18), length 2 (02)
- Device 0 JEDEC id: Manufacturer DF, ID 01

0022: Code 20, link 04
0A 00 00 00

- Tuple CISTPL_MANFID (20), length 4 (04)
- Manufacturer # 0x000A hardware rev 0.00

002E: Code 15, link 12
04 01 53 54 4D 00 53 54 4D 2D x x x x 42 00
00 FF

```
-----
- Tuple CISTPL_VERS_1 (15), length 18 (12)
- Major version 4, minor version 1
- Product Information: Manufacturer: "STM",
- Product name: "STM-xxxxB"
-----

0056: Code 21, link 02
04 01
-----
- Tuple CISTPL_FUNCID (21), length 2 (02)
- Function code 04 (Fixed Disk), system init 01
-----

005E: Code 22, link 02
01 01
-----
- Tuple CISTPL_FUNCE (22), length 2 (02)
- This is a PC Card ATA Disk
-----

0066: Code 22, link 03
02 0C 0F
-----
- Tuple CISTPL_FUNCE (22), length 3 (03)
- VPP is not required
- This is a silicon device
- Identify drive model/serial number is guaranteed unique
- Low-power modes supported: Sleep Standby Idle
- Drive automatically minimizes power
- All modes include 3F7 or 377
- Index bit is not supported
- -IOIS16 is unspecified in twin configurations
-----

0070: Code 1A, link 05
01 03 00 02 0F
```

- Tuple CISTPL_CONFIG (1A), length 5 (05)
- Last valid configuration index is 3
- Configuration register base address is 200
- Configuration registers present: configuration option register at 200
- Card configuration and Status register at 202
- Pin Replacement register at 204
- Socket and Copy register at 206

007E: Code 1B, link 08
 C0 C0 A1 01 55 08 00 20

- Tuple CISTPL_CFTABLE_ENTRY (1B), length 8 (08)
- Configuration table index is 00 (default)
- Interface type is memory
- BVDs not active, WP not active, RdyBsy active
- Wait signal support required
- V_{CC} Power Description: Nom V = 5.0 V
- map 2048 bytes of memory to card address 0
- Miscellaneous Features: Max Twins 0, -Audio, -ReadOnly, +PowerDown

0092: Code 1B, link 06
 00 01 21 B5 1E 4D

- Tuple CISTPL_CFTABLE_ENTRY (1B), length 6 (06)
- Configuration table index is 00
- V_{CC} power description: Nom V = 3.30 V, Peak I = 45.0 mA

00A2: Code 1B, link 0A
 C1 41 99 01 55 64 F0 FF FF 20

- Tuple CISTPL_CFTABLE_ENTRY (1B), length 10 (0A)
- Configuration table index is 01 (default)
- Interface type is I/O
- BVDs not active, WP not active, RdyBsy active
- Wait signal support not required
- V_{CC} power description: Nom V = 5.0 V
- Decode 4 I/O lines, bus size 8 or 16
- IRQ may be shared, pulse and level mode interrupts are supported
- Interrupts in mask FFFF are supported
- Miscellaneous Features: Max Twins 0, -Audio, -ReadOnly, +PowerDown

00BA: Code 1B, link 06
01 01 21 B5 1E 4D

- Tuple CISTPL_CFTABLE_ENTRY (1B), length 6 (06)
- Configuration Table Index is 01
- V_{CC} power description: Nom V = 3.30 V,
- Peak I = 45.0 mA

00CA: Code 1B, link 0F
C2 41 99 01 55 EA 61 F0 01 07 F6 03 01 EE 20

- Tuple CISTPL_CFTABLE_ENTRY (1B), length 15 (0F)
- Configuration Table Index is 02 (default)
- Interface type is I/O
- BVDs not active, WP not active, RdyBsy active
- Wait signal support not required
- V_{CC} power description:
- Nom V = 5.0 V
- Decode 10 I/O lines, bus size 8 or 16
- I/O block at 01F0, length 8
- I/O block at 03F6, length 2
- IRQ may be shared, pulse and level mode interrupts are supported
- Only IRQ14 is supported
- Miscellaneous features: Max Twins 0, -Audio, -ReadOnly, +PowerDown

00EC: Code 1B, link 06
02 01 21 B5 1E 4D

- Tuple CISTPL_CFTABLE_ENTRY (1B), length 6 (06)
- Configuration table index is 02
- V_{CC} power description: Nom V = 3.30 V, Peak I = 45.0 mA

00FC: Code 1B, link 0F
C3 41 99 01 55 EA 61 70 01 07 76 03 01 EE 20

-
- Tuple CISTPL_CFTABLE_ENTRY (1B), length 15 (0F)
 - Configuration table index is 03 (default)
 - Interface type is I/O
 - BVDs not active, WP not active, RdyBsy active
 - Wait signal support not required
 - V_{CC} power description: Nom V = 5.0 V
 - Decode 10 I/O lines, bus size 8 or 16
 - I/O block at 0170, length 8
 - I/O block at 0376, length 2
 - IRQ may be shared, pulse and level mode interrupts are supported
 - Only IRQ14 is supported
 - Miscellaneous features: Max Twins 0, -Audio, -ReadOnly, +PowerDown

011E: Code 1B, link 06
03 01 21 B5 1E 4D

-
- Tuple CISTPL_CFTABLE_ENTRY (1B), length 6 (06)
 - Configuration table index is 03
 - V_{CC} power description: Nom V = 3.30 V, Peak I = 45.0 mA

012E: Code 14, link 00

-
- Tuple CISTPL_NO_LINK (14), length 0 (00)

0134: Code FF

-
- Tuple CISTPL_END (FF)

11 Package mechanical

In order to meet environmental requirements, Numonyx offers these devices in ECOPACK® packages. These packages have a Lead-free second-level interconnect. The category of second-level Interconnect is marked on the package and on the inner box label, in compliance with JEDEC Standard JESD97.

The maximum ratings related to soldering conditions are also marked on the inner box label. ECOPACK is an ST trademark. ECOPACK specifications are available at: www.numonyx.com.

Figure 9. Type I CompactFlash memory card dimensions

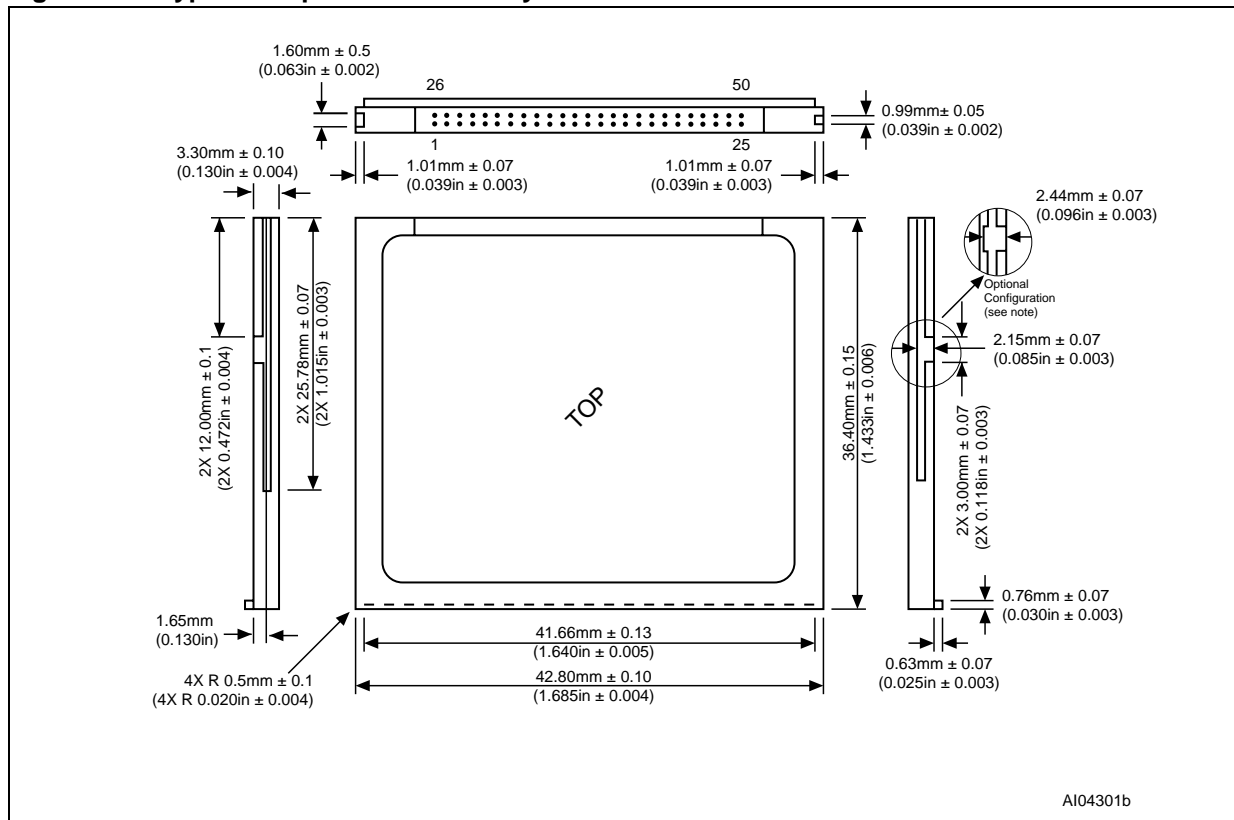

12 Ordering information

Table 81. Ordering information scheme

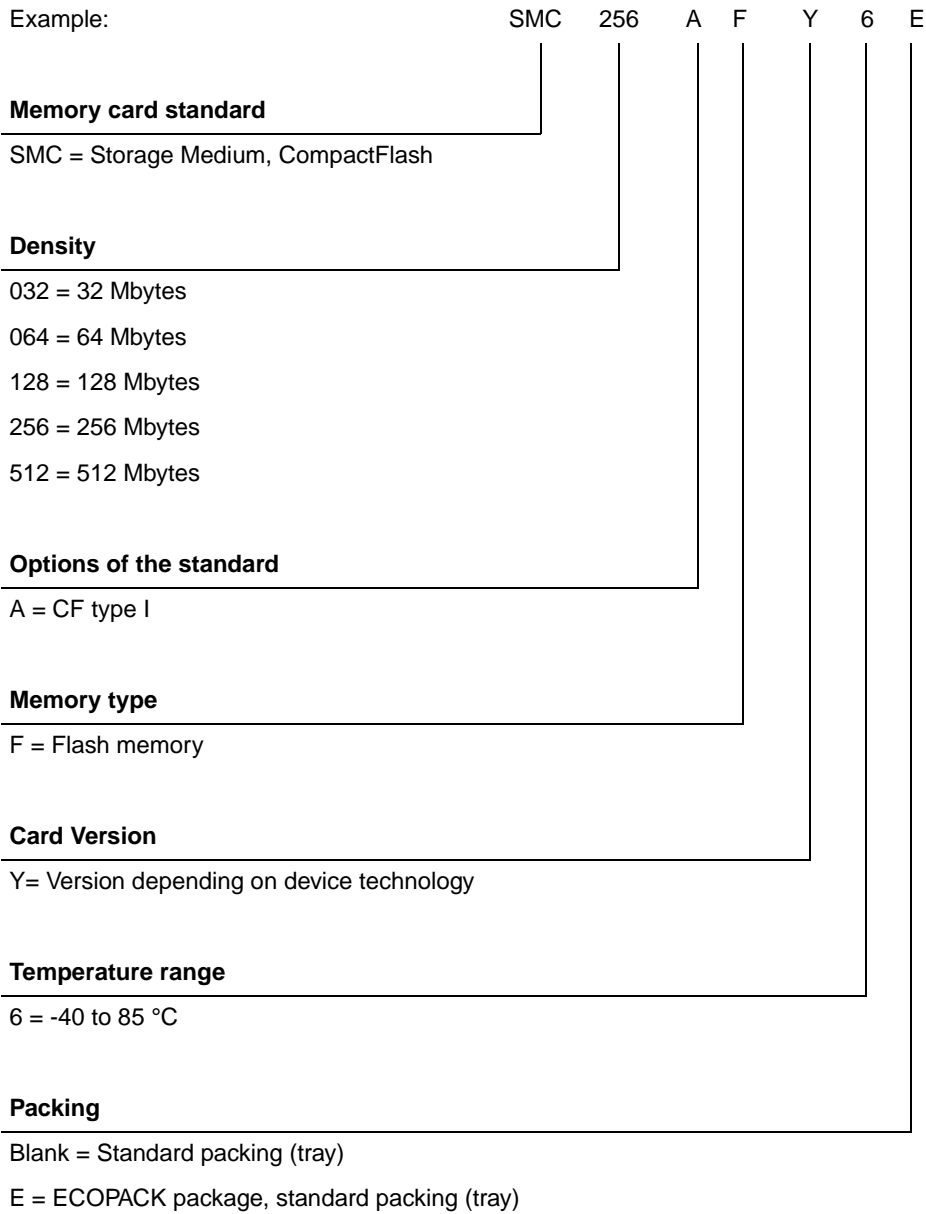

Note: Other digits may be added to the ordering code for preprogrammed parts or other options. Devices are shipped from the factory with the memory content bits erased to '1'. For further information on any aspect of the device, please contact your nearest Numonyx Sales Office.

13 Revision history

Table 82. Document revision history

Date	Revision	Changes
22-Sep-2006	1	Initial release.
14-Nov-2007	2	ECOPACK text added in Section 11: Package mechanical . Minor text changes.
12-Dec-2007	3	Applied Numonyx branding.

Please Read Carefully:

INFORMATION IN THIS DOCUMENT IS PROVIDED IN CONNECTION WITH NUMONYX™ PRODUCTS. NO LICENSE, EXPRESS OR IMPLIED, BY ESTOPPEL OR OTHERWISE, TO ANY INTELLECTUAL PROPERTY RIGHTS IS GRANTED BY THIS DOCUMENT. EXCEPT AS PROVIDED IN NUMONYX'S TERMS AND CONDITIONS OF SALE FOR SUCH PRODUCTS, NUMONYX ASSUMES NO LIABILITY WHATSOEVER, AND NUMONYX DISCLAIMS ANY EXPRESS OR IMPLIED WARRANTY, RELATING TO SALE AND/OR USE OF NUMONYX PRODUCTS INCLUDING LIABILITY OR WARRANTIES RELATING TO FITNESS FOR A PARTICULAR PURPOSE, MERCHANTABILITY, OR INFRINGEMENT OF ANY PATENT, COPYRIGHT OR OTHER INTELLECTUAL PROPERTY RIGHT.

Numonyx products are not intended for use in medical, life saving, life sustaining, critical control or safety systems, or in nuclear facility applications.

Numonyx may make changes to specifications and product descriptions at any time, without notice.

Numonyx, B.V. may have patents or pending patent applications, trademarks, copyrights, or other intellectual property rights that relate to the presented subject matter. The furnishing of documents and other materials and information does not provide any license, express or implied, by estoppel or otherwise, to any such patents, trademarks, copyrights, or other intellectual property rights.

Designers must not rely on the absence or characteristics of any features or instructions marked "reserved" or "undefined." Numonyx reserves these for future definition and shall have no responsibility whatsoever for conflicts or incompatibilities arising from future changes to them.

Contact your local Numonyx sales office or your distributor to obtain the latest specifications and before placing your product order.

Copies of documents which have an order number and are referenced in this document, or other Numonyx literature may be obtained by visiting Numonyx's website at <http://www.numonyx.com>.

Numonyx StrataFlash is a trademark or registered trademark of Numonyx or its subsidiaries in the United States and other countries.

*Other names and brands may be claimed as the property of others.

Copyright © 11/5/7, Numonyx B.V. All Rights Reserved.