

**Harvatek Surface Mount LED Data Sheet
HT-F199 InGaN Series**

Official Product	HT-F199 InGaN Series		Data Sheet No.
Tentative Product			HT-F199 InGaN Series
Specifications are subject to change without notice. Data and drawings herein are copyrighted.	Jul. 10, 2006	Version of 1.1	Page 1/20

DISCLAIMER	3
PRODUCT SPECIFICATIONS	4
ATTENTION: ELECTROSTATIC DISCHARGE (ESD) PROTECTION	4
LABEL SPECIFICATIONS	5
PRODUCT CHARACTERISTICS	9
ABSOLUTE MAXIMUM RATINGS	9
ELECTRO-OPTICAL CHARACTERISTICS	9
PACKAGE OUTLINE DIMENSION	10
RECOMMENDED SOLDERING PATTERN FOR REFLOW SOLDERING	10
CHARACTERISTIC CURVES	11
RADIATION PATTERN	12
PACKAGING	13
TAPE DIMENSION	13
REEL DIMENSION	14
PACKING	15
DRY PACK	16
REFLOW SOLDERING	17
PRECAUTIONS	18
REWORKING	18
CLEANING	18
RELIABILITY TEST	19
REVISION HISTORY	20

Official Product	HT-F199 InGaN Series		Data Sheet No.
Tentative Product			HT-F199 InGaN Series
Specifications are subject to change without notice. Data and drawings herein are copyrighted.	Jul. 10, 2006	Version of 1.1	Page 2/20

DISCLAIMER

HARVATEK reserves the right to make changes without further notice to any products herein to improve reliability, function or design. HARVATEK does not assume any liability arising out of the application or use of any product or circuit described herein; neither does it convey any license under its patent rights, nor the rights of others.

LIFE SUPPORT POLICY

HARVATEK's products are not authorized for use as critical components in life support devices or systems without the express written approval of the President of HARVATEK or HARVATEK INTERNATIONAL. As used herein:

1. Life support devices or systems are devices or systems which, (a) are intended for surgical implant into the body, or (b) support or sustain life, and (c) whose failure to perform when properly used in accordance with instructions for use provided in the labeling, can be reasonably expected to result in a significant injury of the user.
2. A critical component in any component of a life support device or system whose failure to perform can be reasonably expected to cause the failure of the life support device or system, or to affect its safety or effectiveness.

Official Product	HT-F199 InGaN Series		Data Sheet No.
Tentative Product			HT-F199 InGaN Series
Specifications are subject to change without notice. Data and drawings herein are copyrighted.	Jul. 10, 2006	Version of 1.1	Page 3/20

Product Specifications

Product	Emission Color	Technology	Test Current I_F (mA)	Luminous Intensity I_V (mcd)	Forward Voltage V_F (V)	Orderable Part Number
HT-F199NB	Blue	InGaN	20	90 typ	3.3 typ	HT-F199NB-YYYY
HT-F199NG	True Green	InGaN	20	160 typ	3.3 typ	HT-F199NG-YYYY
HT-F199TW	White	InGaN	20	250 typ	3.3 typ	HT-F199TW-YYYY

	Specification	Material	Quantity
Resin	Water clear	Epoxy resin	
Carrier tape	Per EIA 481-1A specs	Conductive black tape	4000pcs per reel
Reel	Per EIA 481-1A specs	Conductive black	
Label	HT standard	Paper	
Packing bag	220x240mm	Aluminum laminated bag/ no-zipper	One reel per bag
Carton	HT standard	Paper	

Others:

Each immediate box consists of 5 reels. The 5 reels may not necessarily have the same lot number or the same bin combinations of I_V , λ_D and V_f . Each reel has a label identifying its specification; the immediate box consists of a product label as well.

ATTENTION: Electrostatic Discharge (ESD) protection



The symbol to the left denotes that ESD precaution is needed. ESD protection for GaP and AlGaAs based chips is necessary even though they are relatively safe in the presence of low static-electric discharge. Parts built with AlInGaP, GaN, or/and InGaN based chips are **STATIC SENSITIVE devices**. ESD precaution must be taken during design and assembly.

If manual work or processing is needed, please ensure the device is adequately protected from ESD during the process.

Official Product	HT-F199 InGaN Series	Data Sheet No.
Tentative Product		HT-F199 InGaN Series
Specifications are subject to change without notice. Data and drawings herein are copyrighted.	Jul. 10, 2006	Version of 1.1
		Page 4/20

Label Specifications

HARVATEK		Date: yyyy/mm/dd
CUSTOMER P/N: 		
HARVATEK P/N: 	QTY: PCS 	
LOT NO: 		QC
IV BIN: COLOR BIN: VF:		

Harvatek P/N:

H T - F199 XX - YYYY

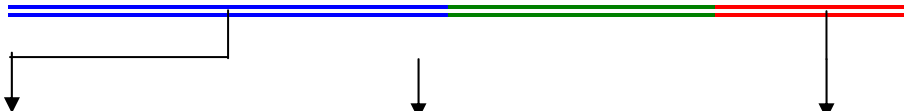

Series Name	Emitting Color	Customer Code
HT-F199 HT: Harvatek F199: 0603 0.25mm series 1.6 (L) x 0.8 (W) x 0.25 (H) mm	XXX NB: Blue NG: True Green TW: White	YYYY Customer Product Code (TBD)

Lot No.:

1	2	3	4	5	6	7	8	9	10
P	1	2	2	3	0	A	-	D	T

Official Product	HT-F199 InGaN Series		Data Sheet No.
Tentative Product			HT-F199 InGaN Series
Specifications are subject to change without notice. Data and drawings herein are copyrighted.	Jul. 10, 2006	Version of 1.1	Page 5/20

Code 1	Code 2	Code 3	Code 4, 5	Code 6, 7	Code 9	Code 10
	Mfg. Year	Mfg. Month	Mfg. Date	Lots	Resin Color	Packaging
Internal Tracing Code	Z: 2000 1: 2001 2: 2002 3: 2003	1: Jan. 2: Feb. 9: Sep. A: Oct. B: Nov. C: Dec.	1~31/ (30)	01~99, A,B,C...	D: Diffused C: Clear	T: Tape & Reel

▣ Luminous Intensity (I_v) Bin:

Bin	Luminous Intensity Range (mcd)		Bin	Luminous Intensity Range (mcd)	
	Minimum	Maximum		Minimum	Maximum
H1	2.8	3.6	H2	3.6	4.5
J1	4.5	5.7	J2	5.7	7.2
K1	7.2	9.0	K2	9.0	11.2
L1	11.2	14.2	L2	14.2	18.0
M1	18.0	22.5	M2	22.5	28.5
N1	28.5	36.0	N2	36.0	45.0
P1	45.0	57.0	P2	57.0	71.5
Q1	71.5	90.0	Q2	90.0	112.5
R1	112.5	142.0	R2	142.0	180.0
S1	180.0	227.0	S2	227.0	285.0
T1	285.0	360.0	T2	360.0	450.0
U1	450.0	570.0	U2	570.0	715.0

@20mA / Ta=25° C, Tolerance: ± 10%

Official Product	HT-F199 InGaN Series	Data Sheet No.	
Tentative Product		HT-F199 InGaN Series	
Specifications are subject to change without notice. Data and drawings herein are copyrighted.	Jul. 10, 2006	Version of 1.1	Page 6/20

Wavelength (λ_D) Bin:

Bin	Wavelength Range (nm)			
	True Green (NG)		Blue (NB)	
	Min	Max	Min	Max
-				
A	515.0	520.0	460.0	464.0
B	520.0	525.0	464.0	468.0
C	525.0	530.0	468.0	472.0
D	530.0	535.0	472.0	476.0
E	535.0	540.0	476.0	480.0
F			480.0	485.0
H				
J				

@20mA / Ta=25° C, Tolerance: \pm 0.5nm

Forward Voltage (V_F) Bin:

Color	Bin Code	Spec. Range
Blue (NB) Green (NG) White (TW)	G8	2.7-2.9 V
	H7	2.9-3.1 V
	H8	3.1-3.3 V
	J7	3.3-3.5 V
	J8	3.5-3.7 V
	K7	3.7-3.9 V

@20mA / Ta=25°C, Tolerance: \pm 0.05 V

Official Product	HT-F199 InGaN Series		Data Sheet No.
Tentative Product			HT-F199 InGaN Series
Specifications are subject to change without notice. Data and drawings herein are copyrighted.	Jul. 10, 2006	Version of 1.1	Page 7/20

Chromaticity Bin (for TW only):

		Rank A0			
x		0.280	0.264	0.283	0.296
y		0.248	0.267	0.305	0.276

		Rank C0			
x		0.330	0.330	0.361	0.356
y		0.318	0.360	0.385	0.351

		Rank B3			
x		0.287	0.283	0.304	0.307
y		0.295	0.305	0.330	0.315

		Rank B5			
x		0.296	0.287	0.307	0.311
y		0.276	0.295	0.315	0.294

		Rank B4			
x		0.307	0.304	0.330	0.330
y		0.315	0.330	0.360	0.339

		Rank B6			
x		0.311	0.307	0.330	0.330
y		0.294	0.315	0.339	0.318

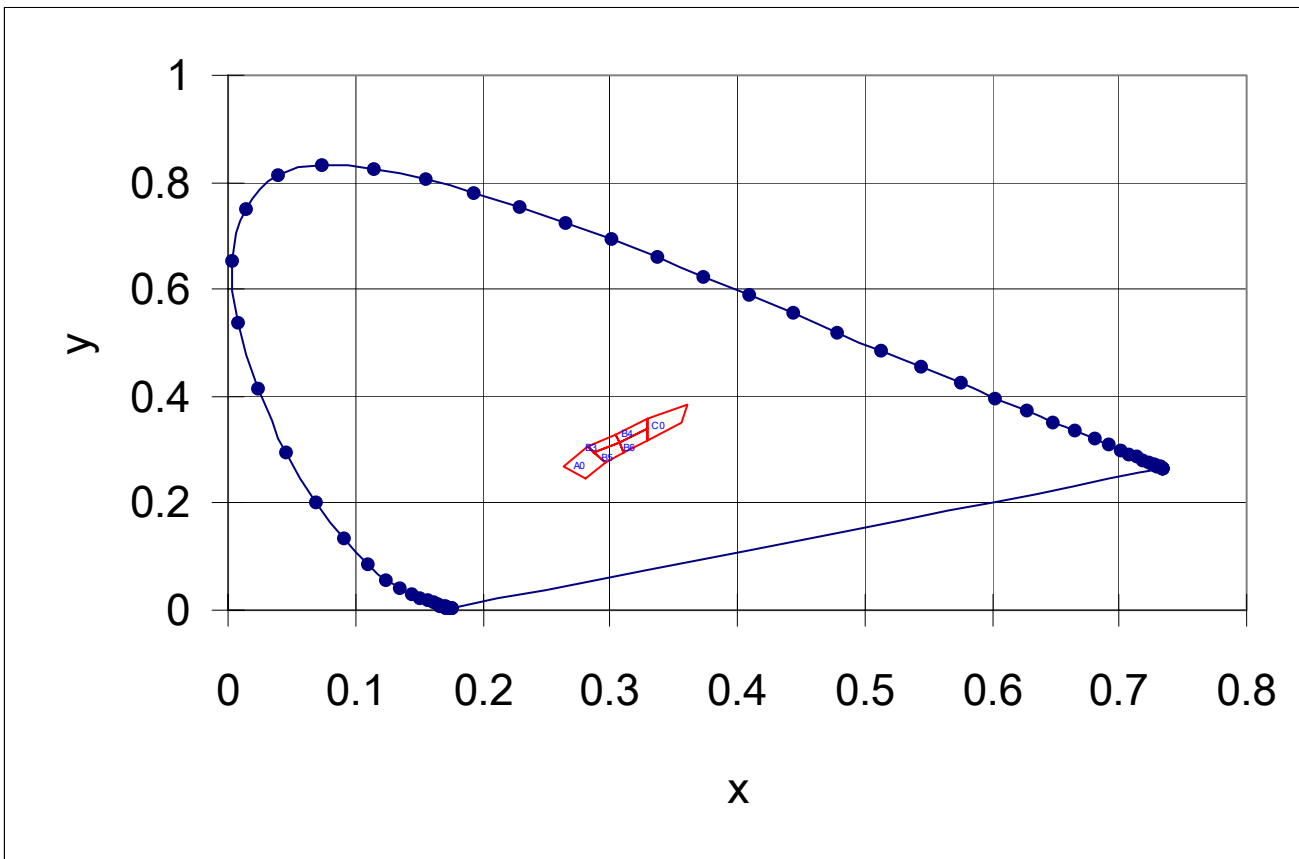

@20mA / Ta=25°C, Tolerance: ± 0.01

Official Product	HT-F199 InGaN Series		Data Sheet No.
Tentative Product			HT-F199 InGaN Series
Specifications are subject to change without notice. Data and drawings herein are copyrighted.	Jul. 10, 2006	Version of 1.1	Page 8/20

Product Characteristics

Absolute Maximum Ratings

Product	Emission Color	P _d (mW)	I _F (mA)	I _{FP} * (mA)	V _R (V)	T _{OP} (°C)	T _{ST} (°C)
HT-F199NB	Blue	117	30	120	5	-40~+100	-40~+100
HT-F199NG	True Green						
HT-F199TW	White						

* Condition for I_{FP} is pulse of 1/10 duty and 0.1msec width

Electro-Optical Characteristics

(T_a = 25 °C)

Product	Emission Color	I _F (mA)	V _F (V)		λ(nm)			I _v (mcd)	
			typ	max	λ _D	λ _P	Δλ	min	typ
HT-F199NB	Blue	20	3.3	3.9	470	468	40	36	90
HT-F199NG	True Green	20	3.3	3.9	527	520	40	90	160
HT-F199TW	White	20	3.3	3.9	X=0.29 Y=0.31	-	-	140	250

* Per NIST standards

Official Product	HT-F199 InGaN Series		Data Sheet No.
Tentative Product			HT-F199 InGaN Series
Specifications are subject to change without notice. Data and drawings herein are copyrighted.		Jul. 10, 2006	Version of 1.1 Page 9/20

Package Outline Dimension
Recommended Soldering Pattern for Reflow Soldering

Unit: mm Tolerance: +/-0.1

Outline Dimension	Solder Pattern
<p>Soldering terminals may shift in the x, y direction.</p>	<p>Unit: mm</p>

Official Product	HT-F199 InGaN Series		Data Sheet No.
Tentative Product			HT-F199 InGaN Series
Specifications are subject to change without notice. Data and drawings herein are copyrighted.	Jul. 10, 2006	Version of 1.1	Page 10/20

Characteristic Curves

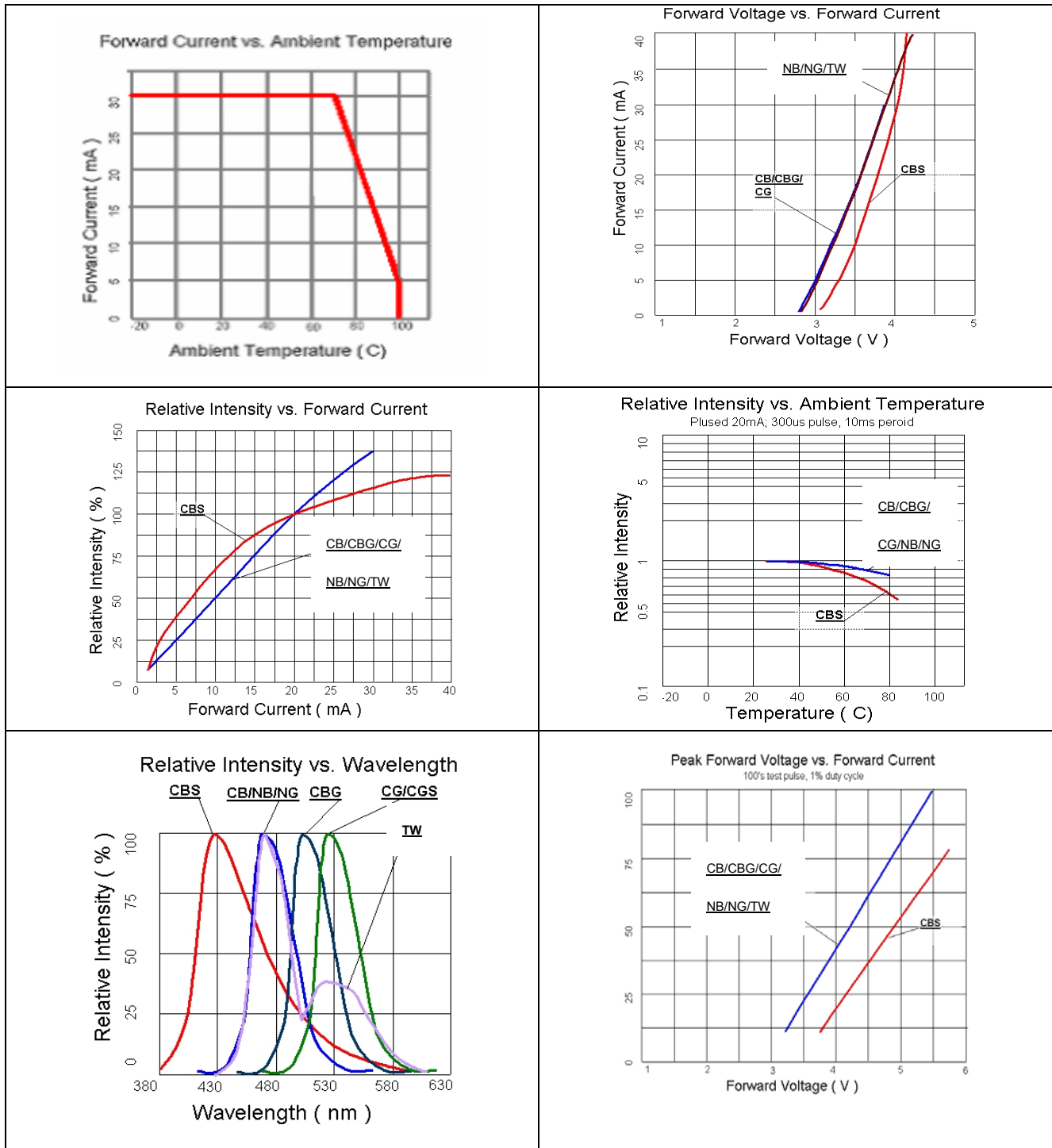

Official Product	HT-F199 InGaN Series	Data Sheet No.	
Tentative Product		HT-F199 InGaN Series	
Specifications are subject to change without notice. Data and drawings herein are copyrighted.	Jul. 10, 2006	Version of 1.1	Page 11/20

Radiation Pattern

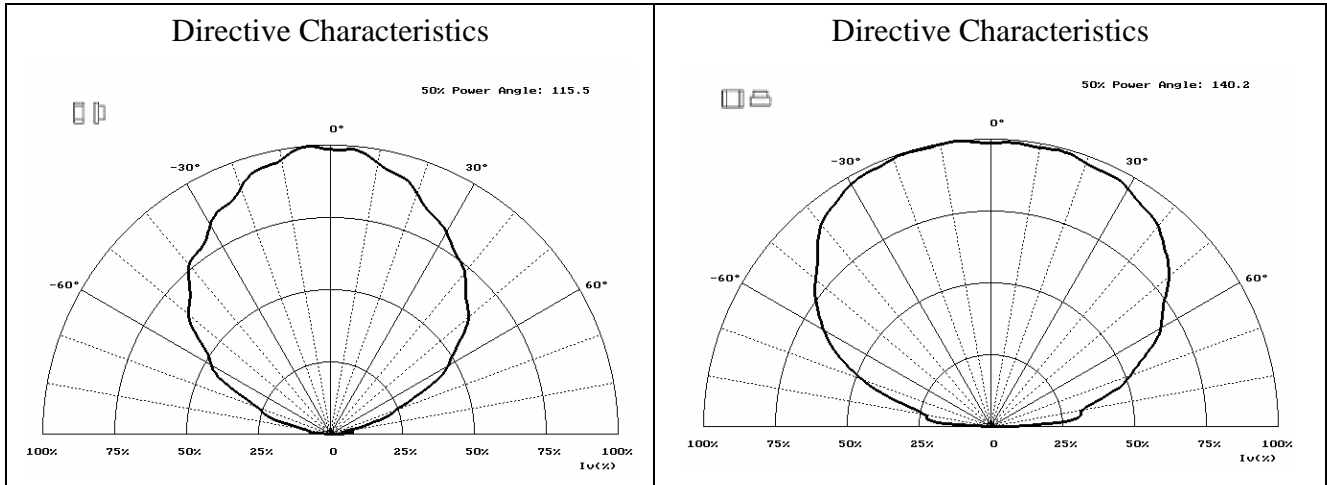

Official Product	HT-F199 InGaN Series		Data Sheet No.
Tentative Product			HT-F199 InGaN Series
Specifications are subject to change without notice. Data and drawings herein are copyrighted.	Jul. 10, 2006	Version of 1.1	Page 12/20

Packaging

Tape Dimension

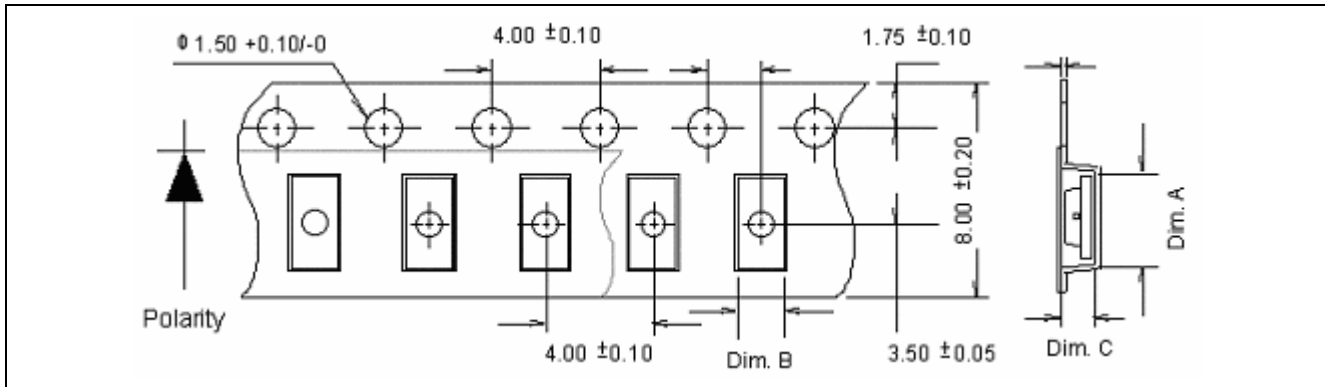

Part No.	Dim. A	Dim. B	Dim. C	Q'ty/Reel
HT-F199	1.80±0.10	0.93±0.10	0.35±0.10	4K

Unit: mm

Official Product	HT-F199 InGaN Series		Data Sheet No.
Tentative Product			HT-F199 InGaN Series
Specifications are subject to change without notice. Data and drawings herein are copyrighted.	Jul. 10, 2006	Version of 1.1	Page 13/20

Reel Dimension

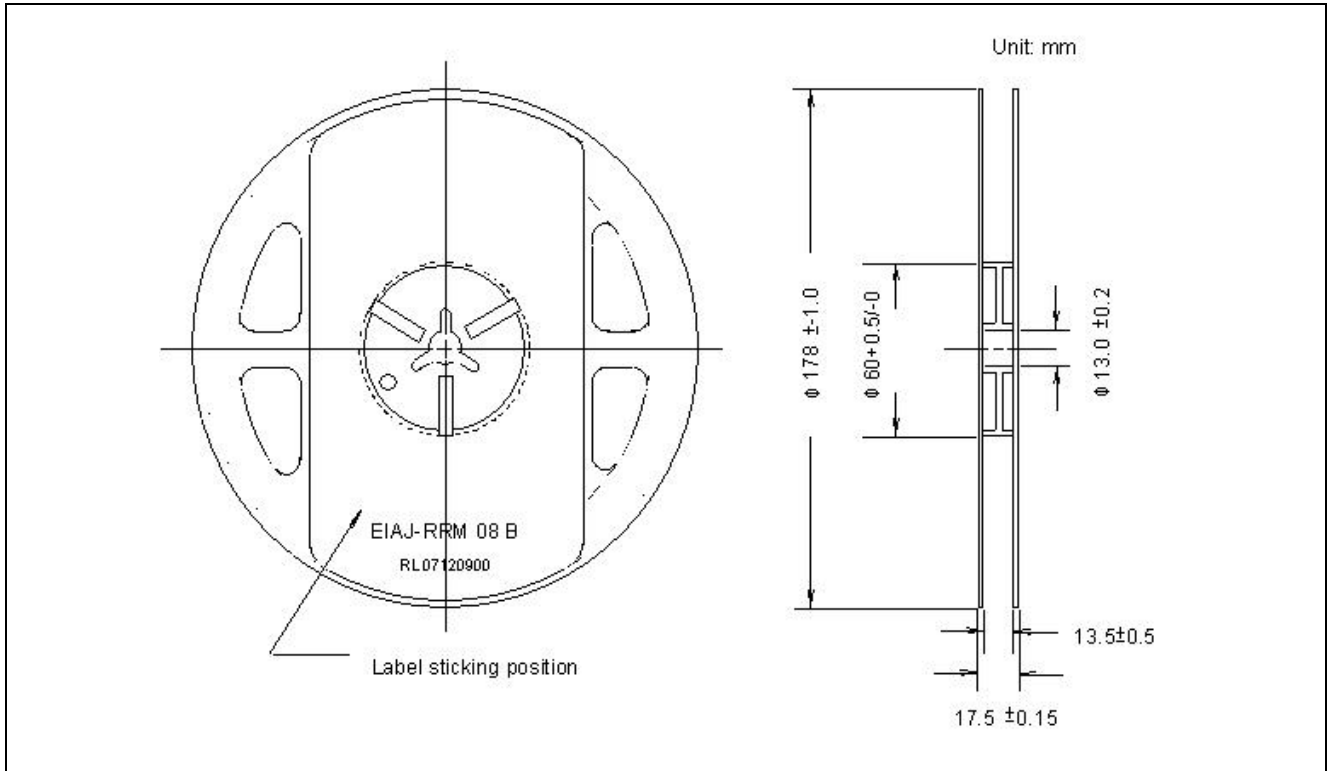

Official Product	HT-F199 InGaN Series		Data Sheet No.
Tentative Product			HT-F199 InGaN Series
Specifications are subject to change without notice. Data and drawings herein are copyrighted.	Jul. 10, 2006	Version of 1.1	Page 14/20

Packing

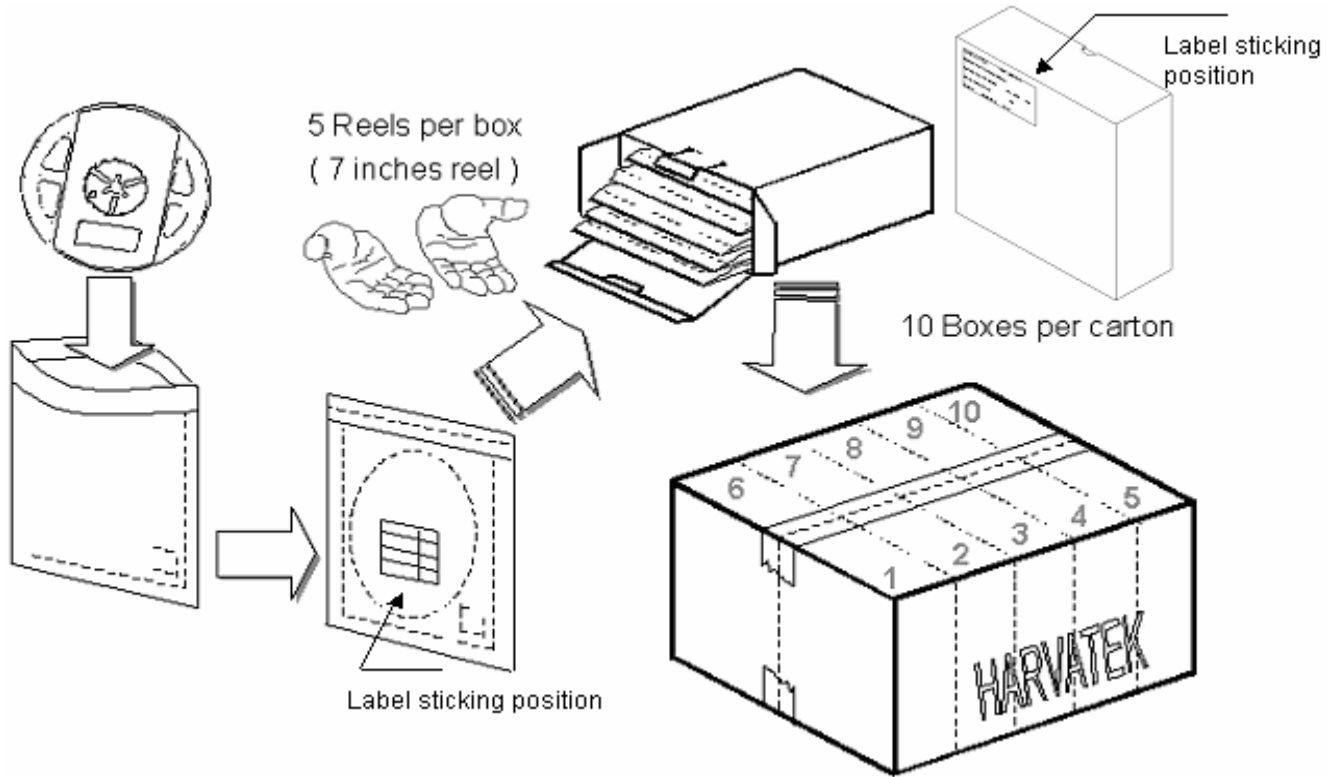

5 boxes per carton is available depending on shipment quantity.

	Specification	Material	Quantity
Carrier tape	Per EIA 481-1A specs	Conductive black tape	4000pcs per reel
Reel	Per EIA 481-1A specs	Conductive black	
Label	HT standard	Paper	
Packing bag	220x240mm	Aluminum laminated bag/ no-zipper	One reel per bag
Carton	HT standard	Paper	Non-specified

Others:

Each immediate box consists of 5 reels. The 5 reels may not necessarily have the same lot number or the same bin combinations of I_v , λ_D and V_f . Each reel has a label identifying its specification; the immediate box consists of a product label as well.

Official Product	HT-F199 InGaN Series		Data Sheet No.
Tentative Product			HT-F199 InGaN Series
Specifications are subject to change without notice. Data and drawings herein are copyrighted.	Jul. 10, 2006	Version of 1.1	Page 15/20

Dry Pack

All SMD optical devices are **MOISTURE SENSITIVE**. Avoid exposure to moisture at all times during transportation or storage. Every reel is packaged in a moisture protected anti-static bag. Each bag is properly sealed prior to shipment.

Upon request, a humidity indicator will be included in the moisture protected anti-static bag prior to shipment.

The packaging sequence is as follows:

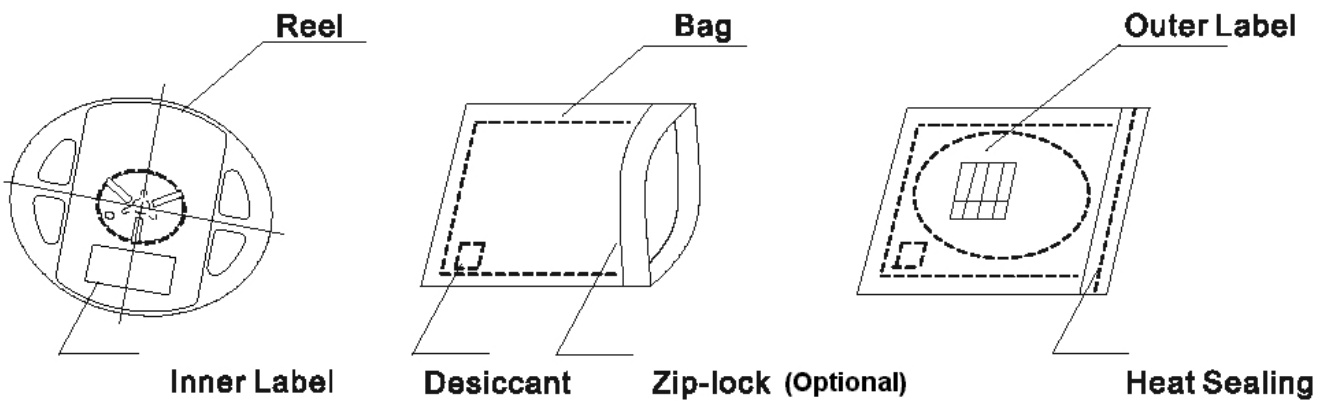

Official Product	HT-F199 InGaN Series		Data Sheet No.
Tentative Product			HT-F199 InGaN Series
Specifications are subject to change without notice. Data and drawings herein are copyrighted.	Jul. 10, 2006	Version of 1.1	Page 16/20

Reflow Soldering

- Recommended tin glue specifications: melting temperature in the range of 178~192 °C
- The recommended reflow soldering profile is as follows (temperatures indicated are as measured on the surface of the LED resin):

Lead Solder Profile

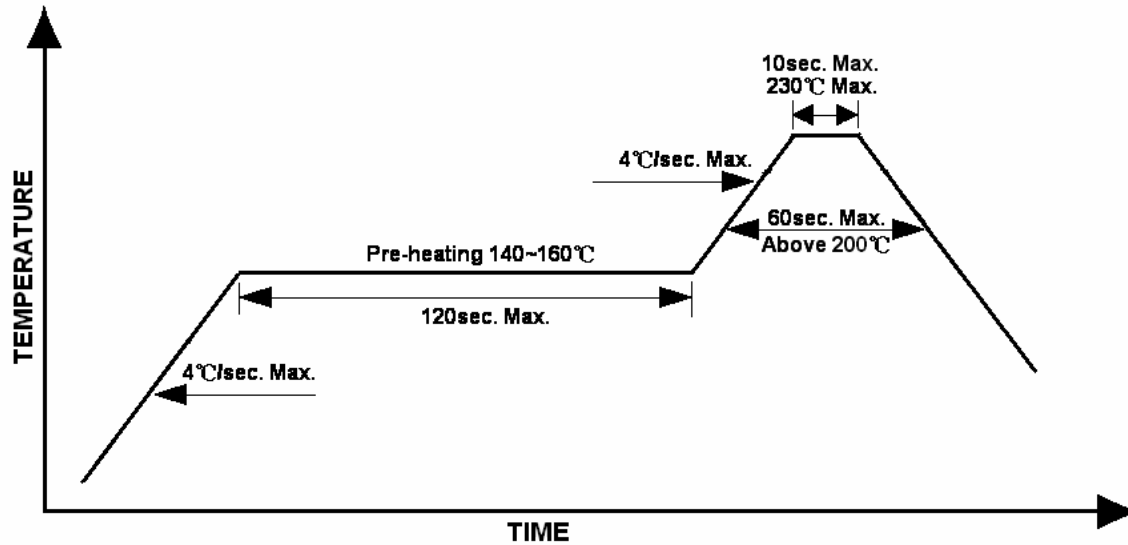

Lead-free Solder Profile

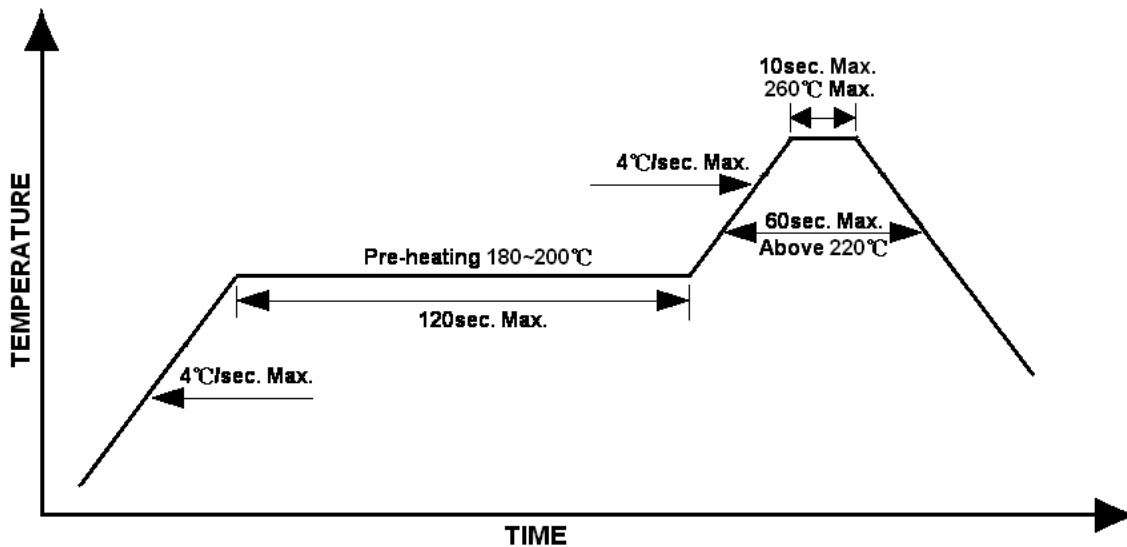

Official Product	HT-F199 InGaN Series		Data Sheet No.
Tentative Product			HT-F199 InGaN Series
Specifications are subject to change without notice. Data and drawings herein are copyrighted.	Jul. 10, 2006	Version of 1.1	Page 17/20

Precautions

1. Avoid exposure to moisture at all times during transportation or storage.
2. Anti-Static precaution must be taken when handling GaN, InGaN, and AlInGaP products.
3. It is suggested to connect the unit with a current limiting resistor of the proper size. Avoid applying a reverse voltage beyond the specified limit.
4. Avoid operation beyond the limits as specified by the absolute maximum ratings.
5. Avoid direct contact with the surface through which the LED emits light.
6. If possible, assemble the unit in a clean room or dust-free environment.

Reworking

- Rework should be completed within 5 seconds under 260 °C.
- The iron tip must not come in contact with the copper foil.
- Twin-head type is preferred.

Cleaning

Following are cleaning procedures after soldering:

- An alcohol-based solvent such as isopropyl alcohol (IPA) is recommended.
- Temperature x Time should be 50°C x 30sec. or <30°C x 3min
- Ultra sonic cleaning: < 15W/ bath; bath volume ≤ 1liter
- Curing: 100 °C max, <3min

Cautions of Pick and Place

- Avoid stress on the resin at elevated temperature.
- Avoid rubbing or scraping the resin by any object.
- Electro-static may cause damage to the component. Please ensure that the equipment is properly grounded. Use of an ionizer fan is recommended.

Official Product	HT-F199 InGaN Series		Data Sheet No.
Tentative Product			HT-F199 InGaN Series
Specifications are subject to change without notice. Data and drawings herein are copyrighted.	Jul. 10, 2006	Version of 1.1	Page 18/20

Reliability Test

Item	Frequency/ lots/ samples/ failures	Standards Reference	Conditions
Precondition	For all reliability monitoring tests according to JEDEC Level 2	J-STD-020	1.) Baking at 85°C for 24hrs 2.) Moisture storage at 85°C/ 60% R.H. for 168hrs
Solderability	1Q/ 1/ 22/ 0	JESD22-B102-B And CNS-5068	Accelerated aging 155°C/ 24hrs Tinning speed: 2.5±0.5cm/s Tinning: A: 215°C/ 3±1s or B: 260°C/ 10±1s
Resistance to soldering heat		CNS-5067	Dipping soldering terminal only Soldering bath temperature A: 260±/-5°C; 10±/-1s B: 350±/-10°C; 3±/-0.5s
Operating life test	1Q/ 1/ 40/ 0	CNS-11829	1.) Precondition: 85°C baking for 24hrs 85°C/ 60%R.H. for 168hrs 2.) T _{amb} 25°C; I _F =20mA; duration 1000hrs
High humidity, high temperature bias	1Q/ 1/ 45/ 0	JESD-A101-B	T _{amb} : 85°C Humidity: 85% R.H., I _F =5mA Duration: 1000hrs
High temperature bias	1Q/ 1/ 20/ 0	HT specs.	T _{amb} : 55°C I _F =20mA Duration: 1000hrs
Pulse life test	1Q/ 1/ 40/ 0		T _{amb} 25°C, I _F =20mA, I _p =100mA, Duty cycle=0.125 (tp=125µs, T=1sec) Duration 500hrs)
Temperature cycle	1Q/ 1/ 76/ 0	JESD-A104-A IEC 68-2-14, Nb	A cycle: -40 degree C 15min; +85 degree C 15min Thermal steady within 5 min.. 300 cycles 2 chamber/ Air-to-air type
High humidity storage test	1Q/ 1/ 40/ 0	CNS-6117	60±3°C 90+5/-10% R.H. for 500hrs
High temperature storage test	1Q/ 1/ 40/ 0	CNS-554	100±10°C for 500hrs
Low temperature storage test	1Q/ 1/ 40/ 0	CNS-6118	-40±5°C for 500hrs

Official Product	HT-F199 InGaN Series		Data Sheet No.
Tentative Product			HT-F199 InGaN Series
Specifications are subject to change without notice. Data and drawings herein are copyrighted.	Jul. 10, 2006	Version of 1.1	Page 19/20

Revision History

Changes since last revision	Page	Version No.	Revision Date
Preliminary		1.0	02-13-2006
New format		1.1	07-10-2006

Official Product	HT-F199 InGaN Series		Data Sheet No.
Tentative Product			HT-F199 InGaN Series
Specifications are subject to change without notice. Data and drawings herein are copyrighted.	Jul. 10, 2006	Version of 1.1	Page 20/20