

0326

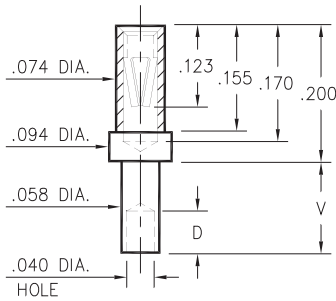

Basic Part Number	Board Thickness	Length V	Depth D
0326-1	.031	.062	.040
0326-2	.062	.094	.062
0326-3	.094	.125	.062
0326-4	.125	.156	.062

0326-X-19-XX-06-XX-10-0
Swage mount in .060 hole

5295

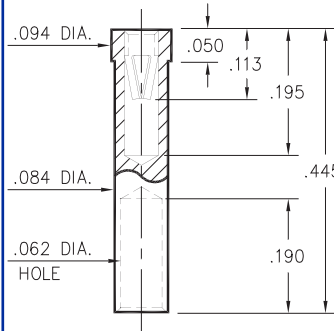

5295-0-19-XX-06-XX-10-0
Solder mount in .086 min. mounting hole

0396

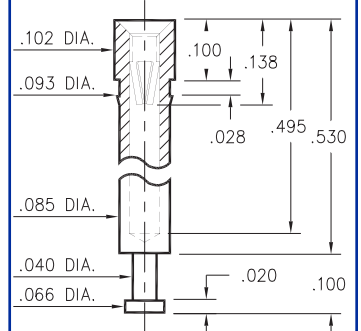

0396-0-15-XX-06-XX-10-0
Press-fit in .090 mounting hole

0298

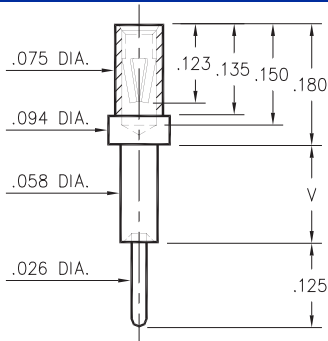

Basic Part Number	Board Thickness	Length V
0298-1	.031	.051
0298-2	.062	.082
0298-3	.094	.113
0298-4	.125	.145

0298-X-15-XX-06-XX-10-0
Swage mount in .060 hole

9293

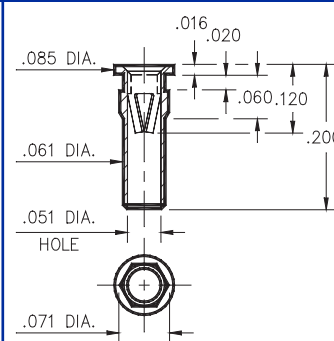

9293-0-15-XX-06-XX-10-0
Hex press-fit in .067 plated thru hole

8864

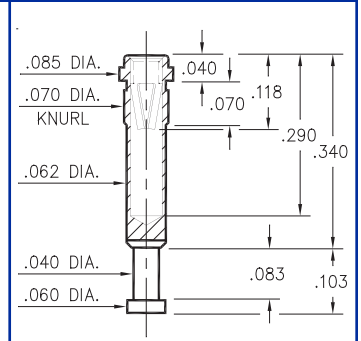

8864-0-15-XX-06-XX-10-0
Press-fit in .067 mounting hole

0664

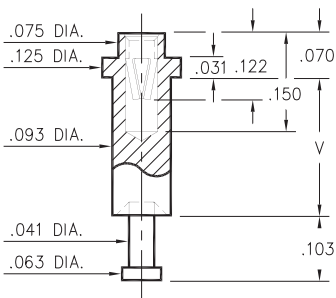

Basic Part Number	Board Thickness	Length V
0664-1	.094	.125
0664-2	.125	.156
0664-3	.188	.219

0664-X-15-XX-06-XX-10-0
Swage mount in .096 hole

SPECIFICATIONS

SHELL MATERIAL:
Brass Alloy 360, 1/2 Hard

CONTACT MATERIAL:
Beryllium Copper Alloy 172, HT

DIMENSION IN INCHES
TOLERANCES ON:
LENGTHS: ±.005
DIAMETERS: ±.002
ANGLES: ± 2°

ORDER CODE: XXXX - X - 1X - XX - 06 - XX - 10 - 0

BASIC PART # →

SPECIFY SHELL FINISH:
01 200μ" TIN/LEAD OVER NICKEL
◇ 80 200μ" TIN OVER NICKEL (RoHS)
◇ 15 10μ" GOLD OVER NICKEL (RoHS)

SPECIFY CONTACT FINISH:
01 200μ" TIN/LEAD OVER NICKEL
◇ 80 200μ" TIN OVER NICKEL (RoHS)
◇ 27 30μ" GOLD OVER NICKEL (RoHS)



CONTACT

#06 CONTACT (DATA ON PAGE 220)