

Part Number:

254-ECM944-RO

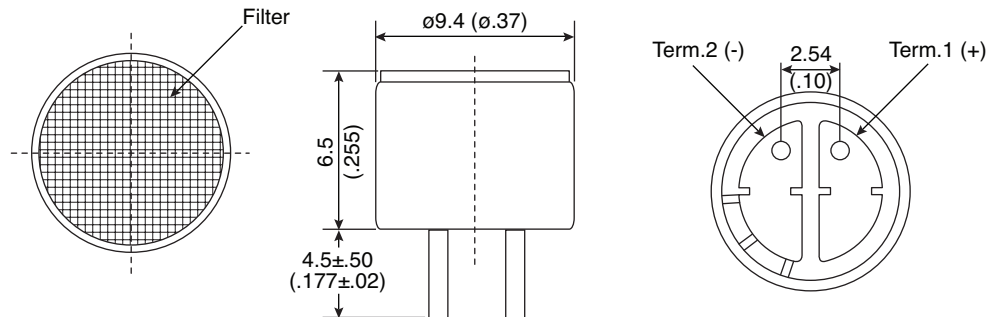

Frequency Response Curve

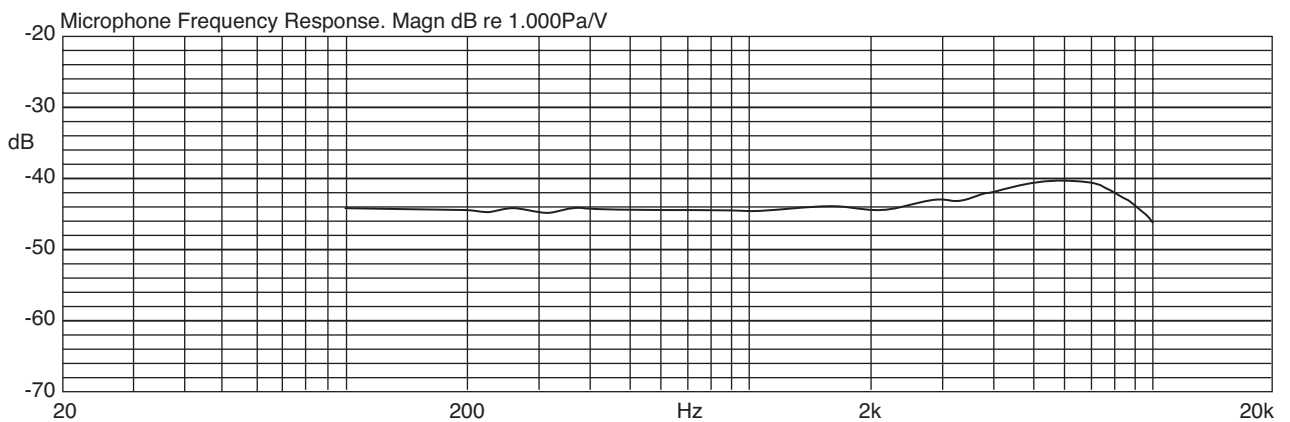

Microphone

KT-400484

Electrical Specifications:

- Sensitivity: -44±2dB
- Standard Operation Voltage: 4.5V
- Frequency Range: 70-20K Hz
- Current Consumption: 0.5mA (max)
- Output Impedance: 2.2kΩ (max)
- S/N Ratio: ≥58db
- Sound Pressure Level: 110dB

Mechanical Specifications:

- Operating Temperature: -20°C to +60°C
- Storage Temperature: -25°C to +70°C

Note:

- RoHS Compliant

Mouser Electronics

Authorized Distributor

Click to View Pricing, Inventory, Delivery & Lifecycle Information:

[Kobitone:](#)

[254-ECM944-RO](#)