



PRELIMINARY

Y/C MIX

■ **FEATURE**

1. Y/C mix circuit
2. Output and Chrominance muting function
3. Output protection function
4. SAG correction function
5. A load sufficient for driving two circuits
6. Low power consumption, 60mw typical
7. Internal voltage clamp circuit

■ **APPLICATION**

- VCR
- Video Camera
- TV
- Video Player

■ **DESCRIPTION**

AA8600AP is a Y/C mix with 6db gain, 75Ω output buffer and SAG correction. The 75Ω buffer is capable of driving two circuits. The SAG could reduce the capacitance of output coupling capacitor. The Y signal is clamped input, while the C signal is biased input. The power saving circuit provides the output and chrominance muting function. The IC is available in 8-pin TSSOP.

■ **BLOCK DIAGRAM & PIN ASSIGNMENT**

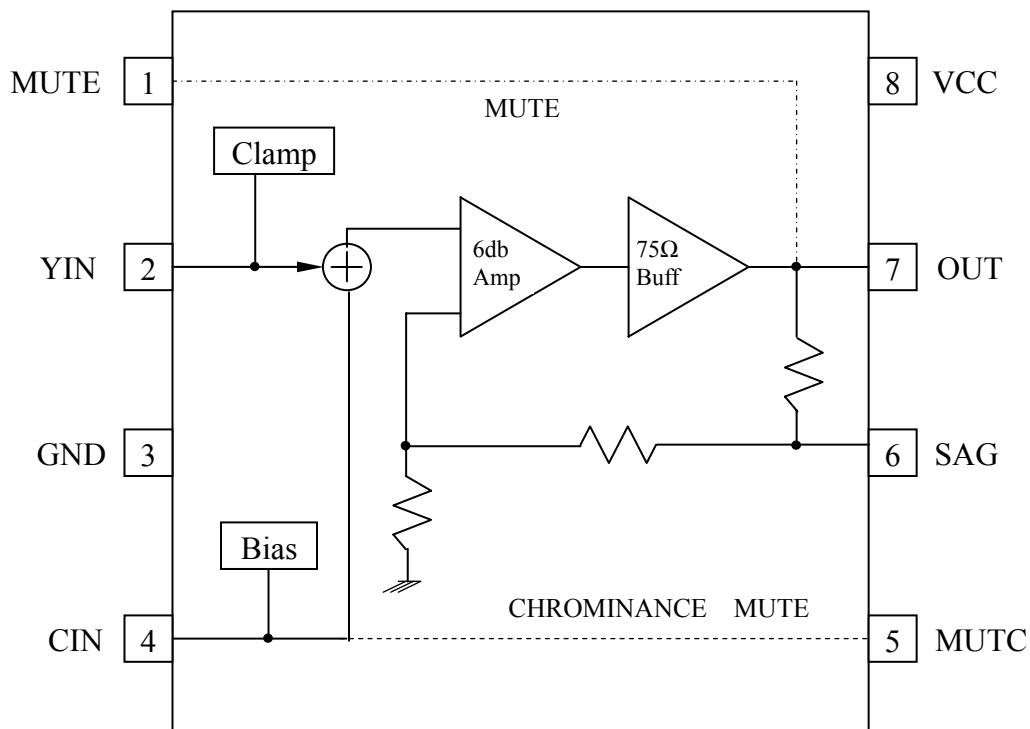



PRELIMINARY

Y/C MIX

■ **PIN DESCRIPTION**

Symbol	Pin-No	Type	Function
MUTE	1	I	Output is muted as this pin is set to high
YIN	2	I	Composite Y input signal is clamped input
GND	3		Ground
CIN	4	I	Chrominance C input signal is bias input
MUTC	5	I	Only chrominance output signal is muted as this pin is set to high
SAG	6	O	SAG correction to reduce the capacitance of output coupling capacitor
OUT	7	O	Y/C mix output. As it is less than 0.6V, the protect circuit is triggered to enable the power saving function
VCC	8		Power supply

■ **ABSOLUTE MAXIMUM RATING**

Ta = 25

Parameter	Symbol	Rating			UNIT	CONDITION
		MIN	TYP	MAX		
Supply Voltage	Vcc	-0.3		8	V	
Operating Ambient Temperature	Ta	-25		75		
Storage Temperature	Ts	-55		125		

NOTE : Stress above those listed under “Absolute Maximum Rating” may cause permanent damage to the device. This is a stress rating only and functional operation of the device at these or any other conditions above those indicated in the operational section of this specification is not implied. Exposure to absolute maximum rating conditions for the extended periods of time may affect device reliability.



PRELIMINARY

Y/C MIX

■ **ELECTRICAL CHARACTERISTICS**

Ta = 25 , Vcc = 5V

Parameter	Symbol	Min	Typ	Max	Unit	Condition
Supply Current	Icc		12.6	20	mA	No input Signal
Voltage Gain	Gv		-0.3		dB	Input Signal Freq = 4.43MHz, 1VP-P, measure VO1
Frequency Characteristic	GF	-1.5	-0.5	0.5	dB	Input Signal Freq = 7MHz/1MHz, 1VP-P, measure VO1
Muting Attenuation	MT		-64		dB	Input Signal Freq = 4.43MHz, 1VP-P, measure VO1
Muting High Level	VMH	2.2		Vcc	V	
Muting Low Level	VML	GND		0.8	V	
Input Impedance	ZIN	15	20	25	KΩ	CIN, 50uA
Muted Current	IM		1	2.5	mA	MUTE = 'H'
SAG-Terminal Gain	GSAG		48		dB	
Differential Gain	DG		1	2	%	VIN = 1VP-P, refer staircase signal
Differential Phase	DP		1	2.5	deg	VIN = 1VP-P, refer staircase signal

■ **MUTE MODE**

Function	MUTE	MUTC
Output Muting	H	NA
Chrominance Muting	L	H



■ **MEASUREMENT CIRCUIT**

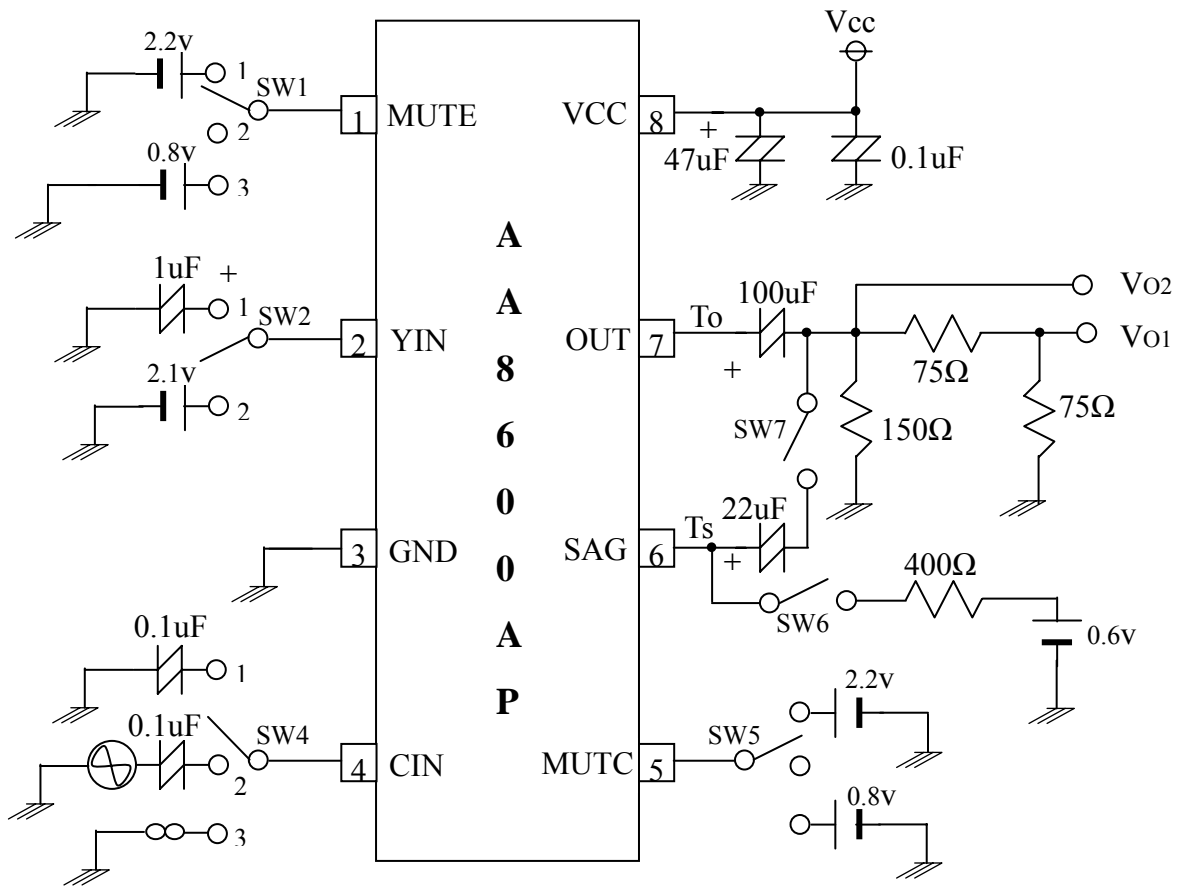



■ MEASUREMENT CONDITIONS

Parameter	Symbol	SW Condition						Measurement Method
		1	2	4	5	6	7	
Supply Current	Icc	2	1	1	2	0	C	No signal input
Voltage Gain	Gv	3	2	2	3	0	C	Input a 4.43MHz, 1Vp-p sine wave from CIN and then measure the output level from VO1
Frequency Characteristic	GF	3	1	2	3	0	C	GV1M : voltage gain at input frequency=1MHz GV7M : voltage gain at input frequency=7MHz GF =GV7M-GV1M
Output Mute	MT	1	1	2	3	0	C	Input a 4.43MHz, 1Vp-p sine wave and then measure the output level from VO1
Chrominance Mute	Mc	3	2	2	1	0	C	Same as output muting
Input Impedance	ZIN	3	1	3	3	0	C	Measure the input voltage VIS & the open voltage VIO when a 50uA is introduced. The $Z_{IN} = V_{IS}-V_{IO} / 50\mu A$
Muted Current	IM	1	1	1	2	0	C	Measure the current of power supply when mute is set at high
AG Terminal Gain	GSAG	3	2	2	3	0	C	Measure the value of Ts and To at the first as VS1 & VO1 and the value at second condition as VS2 & VO2, respectively. $GSAG = 20\log\{(V_{S2} - V_{S1}) / (V_{O2} - V_{O1})\}$
		3	2	2	3	C	O	



■ **APPLICATION**

➤ **With SAG**

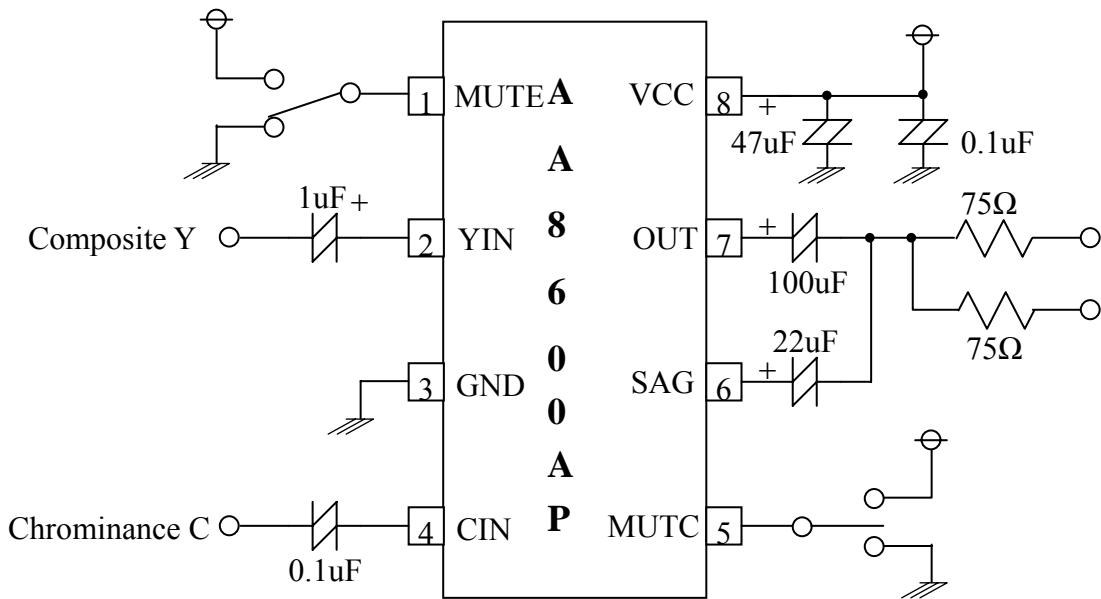

➤ **Without SAG**

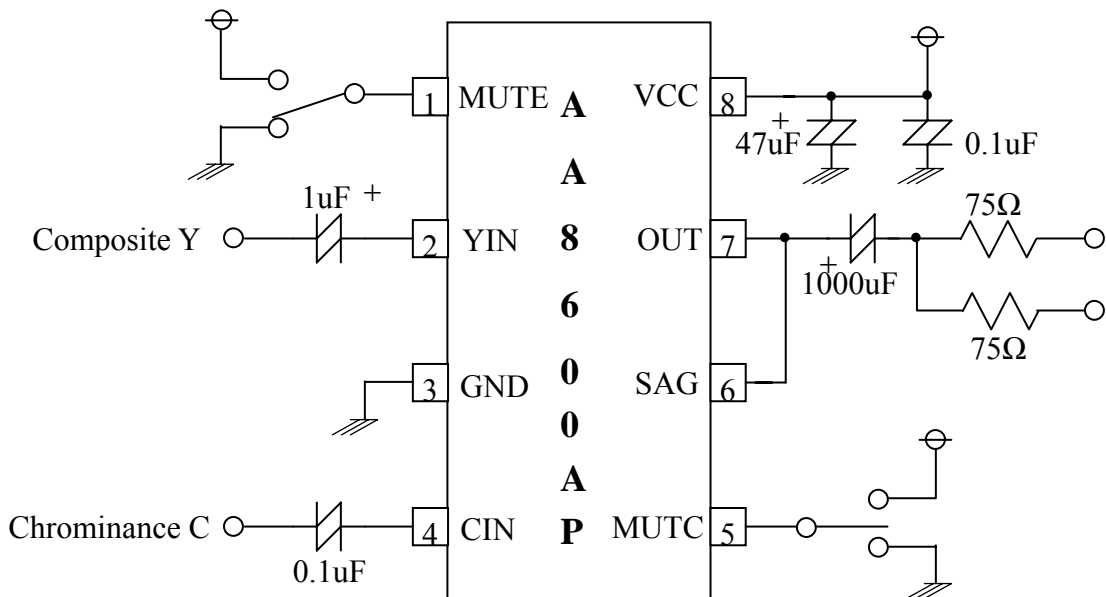



PRELIMINARY

Y/C MIX

■ **TSSOP 8L PACKAGE DIMENSION**

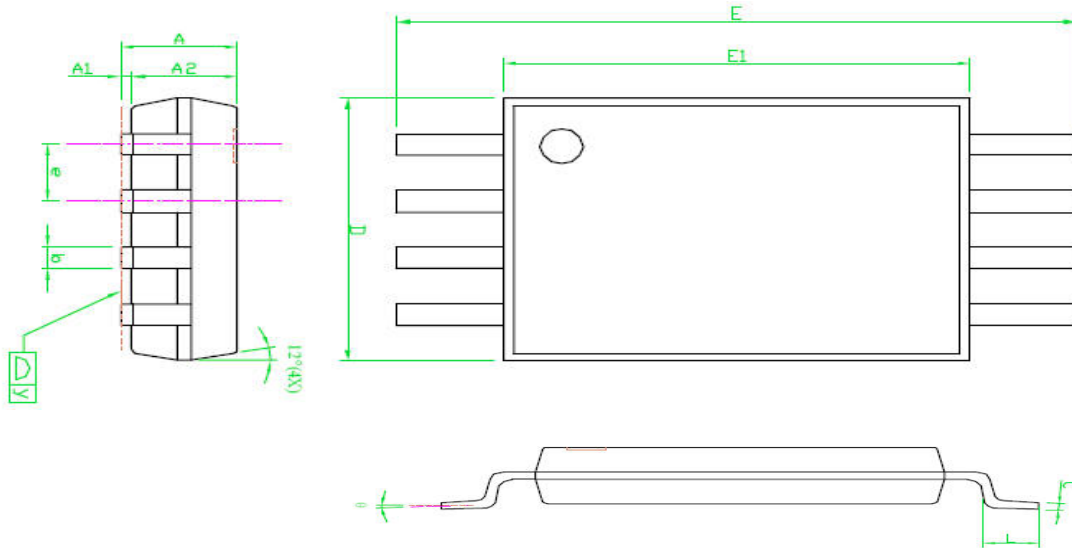

NOTES:

1. Package body sizes exclude mold flash protrusions or gate burrs
2. Tolerance $\pm 0.1 \text{ mm}$ (4 mil) unless otherwise specified
3. Coplanarity: 0.1 mm
4. Controlling dimension is millimeter converted inch dimensions are not necessarily exact
5. Followed from jedec mo-153

SYMBOLS	DIMENSIONS IN MILLIMETERS			DIMENSIONS IN INCHES		
	MIN	NOM	MAX	MIN	NOM	MAX
A	---	---	1.20	---	---	0.048
A1	0.05	---	0.15	0.002	---	0.006
A2	0.80	1.00	1.05	0.031	0.039	0.041
b	0.19	---	0.30	0.007	---	0.012
C	0.09	---	0.20	0.004	---	0.008
D	2.90	3.00	3.10	0.114	0.118	0.122
E	6.20	6.40	6.60	0.244	0.252	0.260
E1	4.30	4.40	4.50	0.169	0.173	0.177
e	---	0.65	---	---	0.026	---
L	0.45	0.60	0.75	0.018	0.024	0.030
y	---	---	0.10	---	---	0.004
	0°	---	8°	0°	---	8°