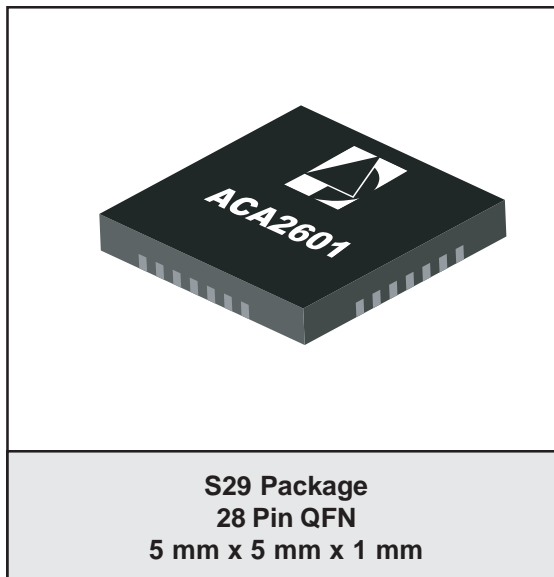


## FEATURES

- 50 - 870 MHz Operating Frequency
- High Linearity: 65 dBc CTB/CSO (79 Chan.)
- Low Equivalent Input Noise: 4.5 pA/rtHz
- 20 dB Gain Adjust
- 400  $\Omega$  Differential Input Impedance: No Transformer Required for Interface to Photodiode
- Single +5 V Supply
- 5 mm x 5 mm x 1 mm Surface Mount Package
- RoHS Compliant Package

## APPLICATIONS

- FTTH RF Amplifier Used in Conjunction With Triplexer in Fiber-Coax Line Terminals



## PRODUCT DESCRIPTION

The ANADIGICS ACA2601 amplifier for Fiber-to-the-Home (FTTH) applications is intended to be used in conjunction with the triplexer in fiber-coax line terminals. The device is driven by, and amplifies the output of, the video downstream path photodiode.

The high-impedance input of the ACA2601 eliminates the need for a costly transformer usually needed to interface to the photodiode, and a low equivalent input noise level offers excellent sensitivity. The device provides sufficient linearity to

maintain low CTB and CSO levels in full-bandwidth (132 channel) systems, even across a wide gain adjustment range.

The ACA2601 is manufactured using ANADIGICS's proven MESFET technology that offers state-of-the-art reliability, temperature stability and ruggedness. The device operates from a single +5V supply and is offered in a 5 mm x 5 mm x 1 mm surface mount package.

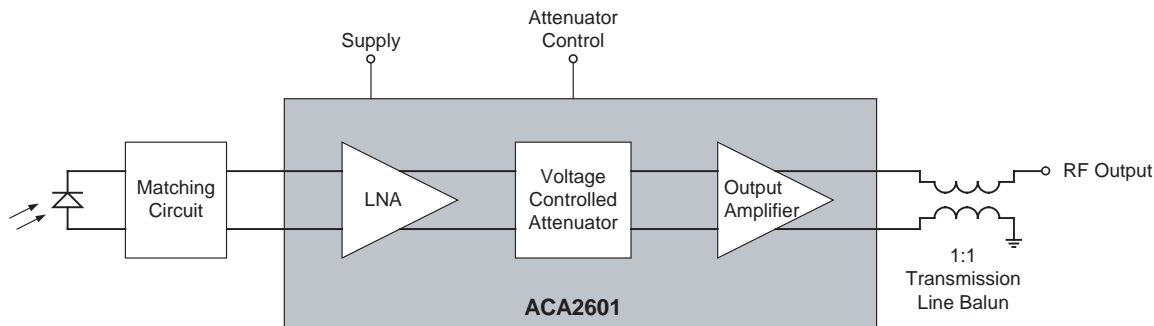
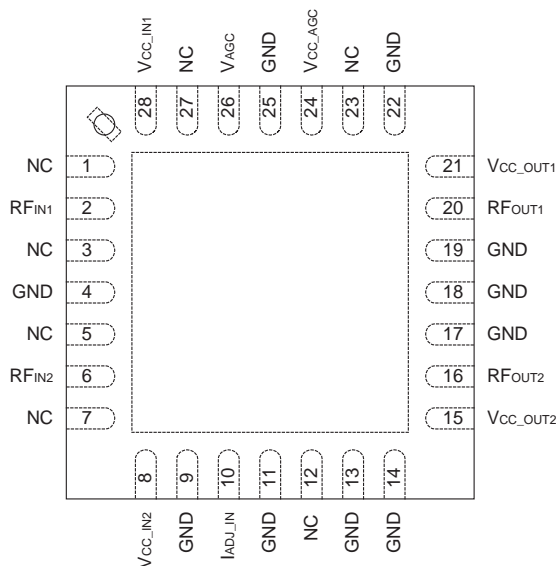


Figure 1: Application Block Diagram



**Figure 2: Pinout (X-ray Top View)**

**Table 1: Pin Description**

PIN	NAME	DESCRIPTION	PIN	NAME	DESCRIPTION
1	NC	No Connection	28	V <sub>CC_IN2</sub>	Input Stage Supply 1
2	RF <sub>IN1</sub>	RF Input 1	27	NC	No Connection
3	NC	No Connection	26	V <sub>AGC</sub>	AGC Control Input
4	GND	Ground	25	GND	Ground
5	NC	No Connection	24	V <sub>CC_AGC</sub>	AGC Supply
6	RF <sub>IN2</sub>	RF Input 2	23	NC	No Connection
7	NC	No Connection	22	GND	Ground
8	V <sub>CC_IN2</sub>	Input Stage Supply 2	21	V <sub>CC_OUT1</sub>	Output Stage Supply 1
9	GND	Ground	20	RF <sub>OUT1</sub>	RF Output 1
10	I <sub>ADJ_IN</sub>	Input Stage Current Adjust	19	GND	Ground
11	GND	Ground	18	GND	Ground
12	NC	No Connection	17	GND	Ground
13	GND	Ground	16	RF <sub>OUT2</sub>	RF Output 2
14	GND	Ground	15	V <sub>CC_OUT2</sub>	Output Stage Supply 2

## ELECTRICAL CHARACTERISTICS

Table 2: Absolute Minimum and Maximum Ratings

PARAMETER	MIN	MAX	UNIT
Supply Voltage ( $V_{CC}$ )	0	+8	V
AGC Voltage ( $V_{AGC}$ )	0	+5	V
RF Input Power ( $P_{IN}$ )	-	+25	dBmV
Storage Temperature	-65	+150	°C

Stresses in excess of the absolute ratings may cause permanent damage. Functional operation is not implied under these conditions. Exposure to absolute ratings for extended periods of time may adversely affect reliability.

Table 3: Operating Ranges

PARAMETER	MIN	TYP	MAX	UNIT	COMMENTS
Operating Frequency (f)	50	-	870	MHz	
Supply Voltage ( $V_{CC}$ )	-	+5	-	V	
RF Output Power ( $P_{OUT}$ )	-	+18	-	dBmV	
Case Temperature ( $T_C$ )	-40	-	+110	°C	

The device may be operated safely over these conditions; however, parametric performance is guaranteed only over the conditions defined in the electrical specifications.

**Table 4: Electrical Specifications**  
 (T<sub>A</sub> = +25 °C, P<sub>OUT</sub> = +18 dBmV, V<sub>CC</sub> = +5 V, 75 Ω system, see Figure 3)

PARAMETER	MIN	TYP	MAX	UNIT	COMMENTS
RF Gain over Temperature <sup>(1)</sup>	20	20.7	-	dB	at 550 MHz
Gain Tilt <sup>(2)</sup> V <sub>AGC</sub> = +3.0 V V <sub>AGC</sub> = +0.5 V	0.5 2.5	1.5 3.5	2.0 4.5	dB	
Gain Tilt over Temperature <sup>(1), (2)</sup> V <sub>AGC</sub> = +3.0 V V <sub>AGC</sub> = +0.5 V	0 2.25	1.5 -	3.0 4.75	dB	
Gain Flatness over Temperature <sup>(1), (3)</sup> V <sub>AGC</sub> = +3.0 V V <sub>AGC</sub> = +0.5 V	- -	0.7 0.5	1.5 1.0	dB	
Gain Adjustment Range	20	22	-	dB	
Gain Adjust Control Voltage	+0.5	-	+3.0	V	Max. gain at +3.0 V
CTB <sup>(5)</sup>	-	-65	-60	dBc	79 Channels
CSO <sup>(5)</sup>	-	-65	-	dBc	79 Channels
OIP2 <sup>(7)</sup>	+47	-	-	dBm	
Equivalent Input Noise (EIN) <sup>(4)</sup>	-	4.5	5.5	pA/rHz	
EIN over Temperature <sup>(1), (4)</sup>	-	5	6	pA/rHz	
Input Impedance	-	400	-	Ω	differential
Output Return Loss <sup>(1), (6)</sup> -30 °C to +85 °C +85 °C to +100 °C	16 15	18 -	- -	dB	differential, 75 Ω system
Current Consumption <sup>(1)</sup>	-	230	295	mA	
Thermal Resistance	-	18	25	°C/W	

## Notes:

- (1) Package slug temperature range of -30 to +100 °C.  
 (2) Recorded tilt of the calculated best fit straight line from 50 to 870 MHz.  
 (3) Flatness is the peak-to-peak deviation from the calculated best fit straight line.  
 (4) Measured using application circuit with photodiode, as shown in Figure 16.  
 (5) Measured at +18 dBmV output power, with 14 dB gain reduction.  
 (6) Over the 50 to 870 MHz Frequency band.  
 (7) Measured using two tones at 379.25 and 301.25 MHz, -12 dBm output power per tone, with 14 dB gain reduction.

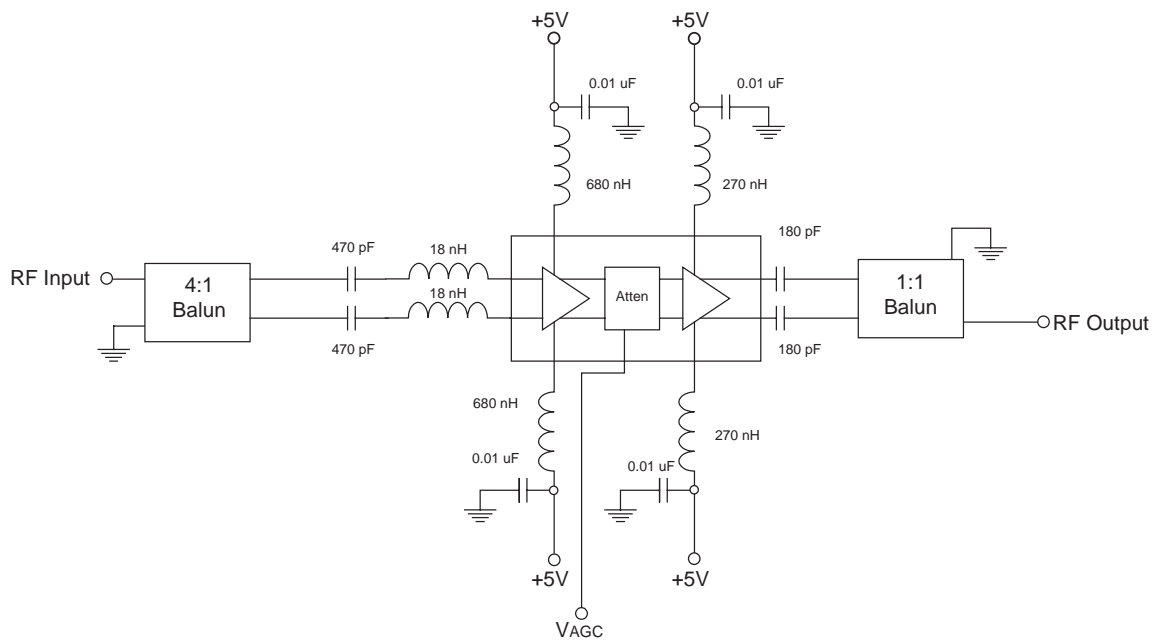


Figure 3: Test Circuit

PERFORMANCE DATA

All performance data measured using application circuit with input photodiode, as shown in Figure 16.

Figure 4: Gain vs. Frequency  
( $T_A = +25\text{ }^\circ\text{C}$ ,  $V_{CC} = +5\text{ V}$ )

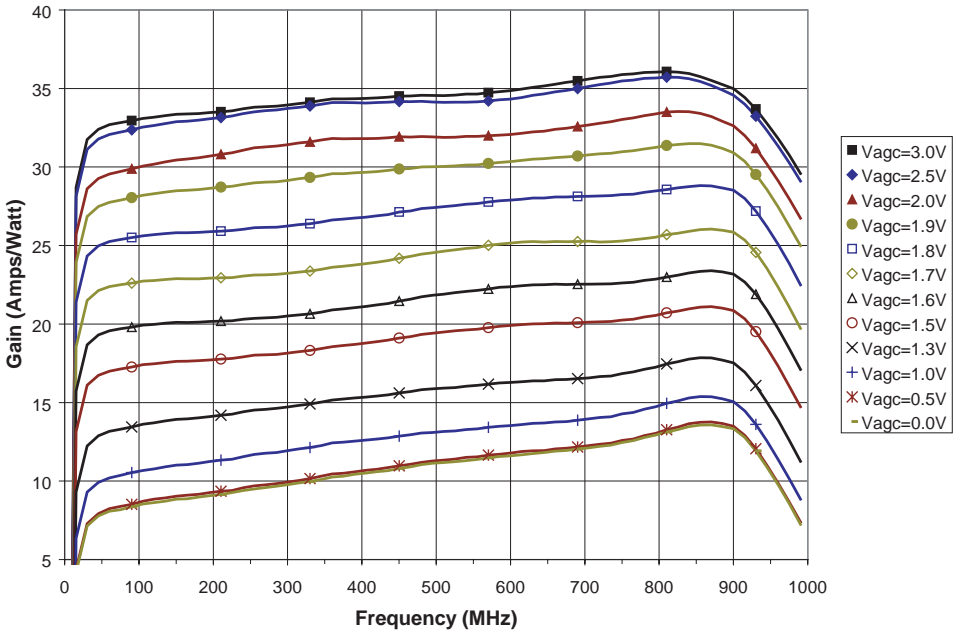
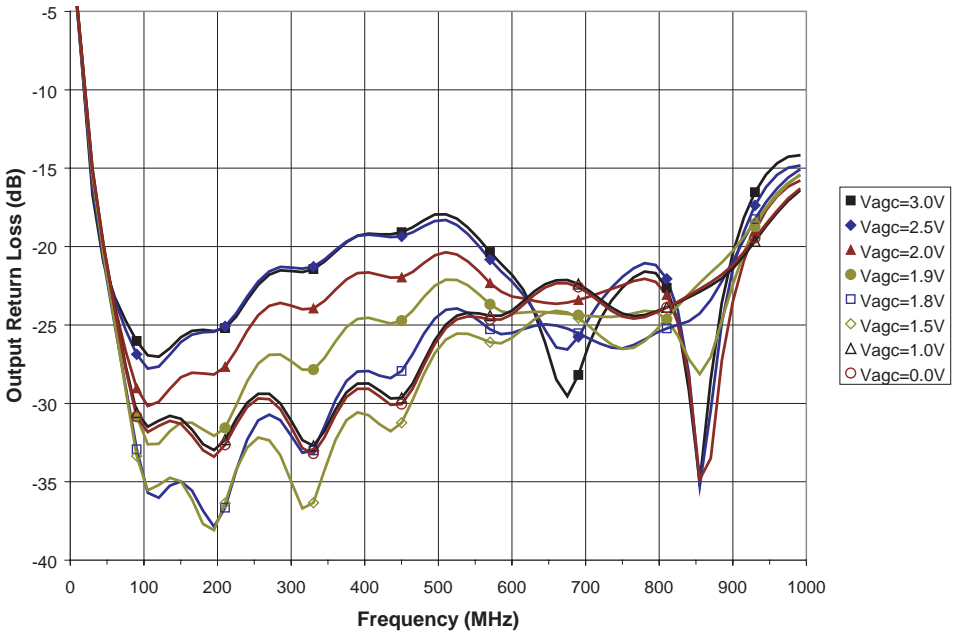
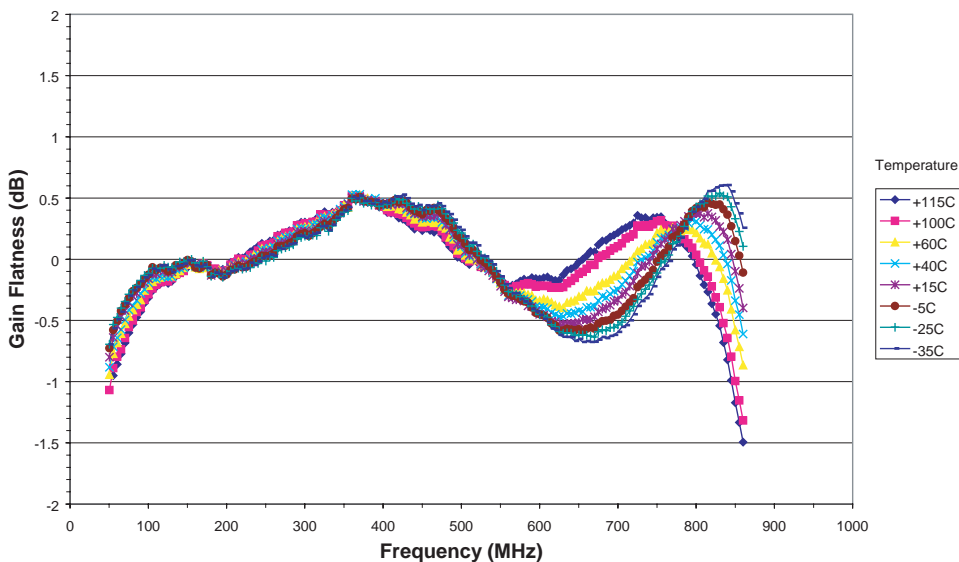


Figure 5: Output Return Loss vs. Frequency  
( $T_A = +25\text{ }^\circ\text{C}$ ,  $V_{CC} = +5\text{ V}$ )



All performance data measured using application circuit with input photodiode, as shown in Figure 16.

**Figure 6: Gain Flatness To Best Fit Line over Temperature**  
( $V_{CC} = +5\text{ V}$ ,  $V_{AGC} = +3.0\text{ V}$ )



**Table 5: Gain Flatness to Best Fit Line**  
( $V_{AGC} = +3.0\text{ V}$ )

Temp (°C)	Tilt (dB)	Flatness (dB)
115	3.5	2
100	3.8	1.8
60	4.4	1.5
40	4.7	1.4
15	5	1.3
-5	5.2	1.2
-25	5.4	1.2
-35	5.6	1.3

The best fit line is calculated using the least mean squares method:

$$y = m \cdot x + b$$

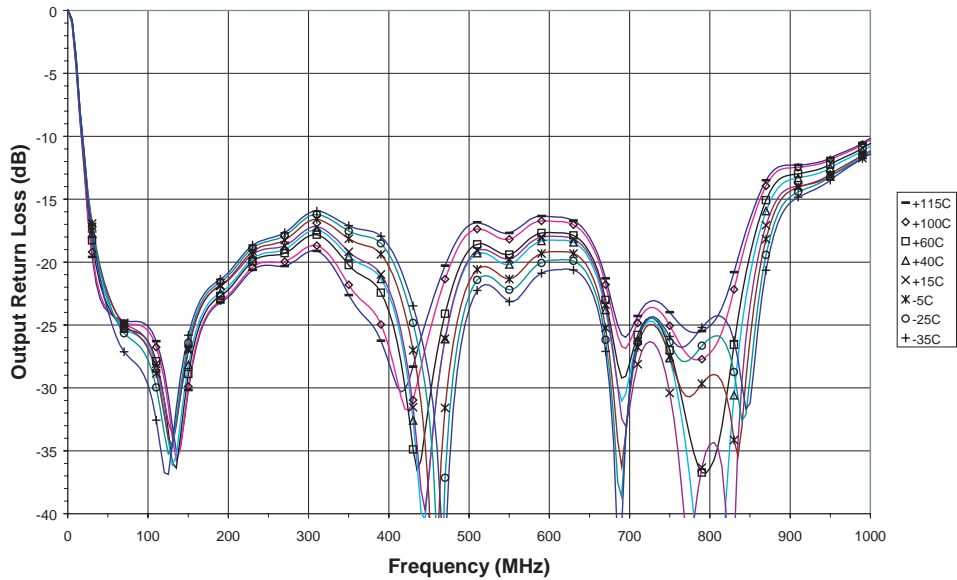
$$m = \frac{\sum(x \cdot y) - \frac{\sum x \cdot \sum y}{n}}{\sum x^2 - \frac{(\sum x)^2}{n}}$$

$$b = \frac{\sum y}{n} - m \cdot \frac{\sum x}{n}$$

$n = \text{number of points}$

All performance data measured using application circuit with input photodiode, as shown in Figure 16.

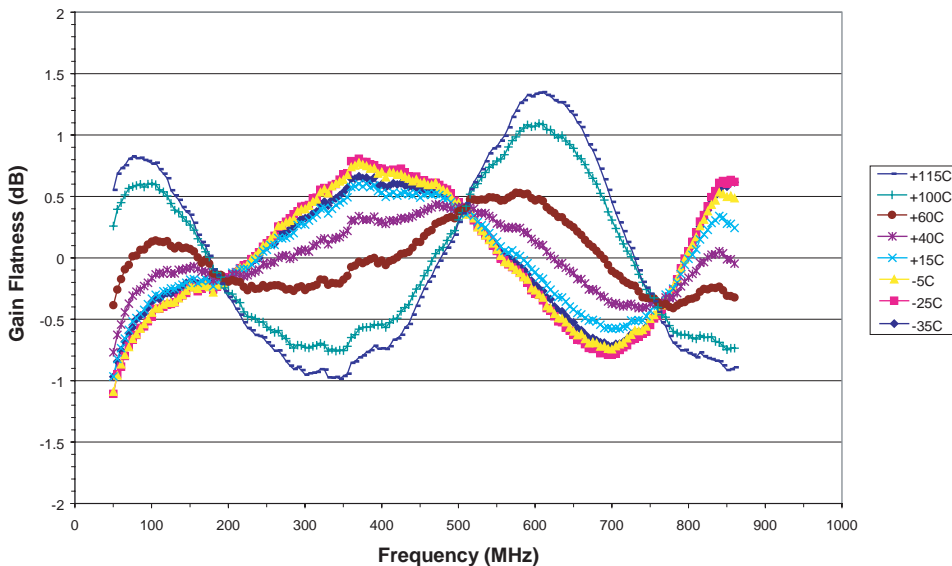
**Figure 7: Output Return Loss over Temperature**  
 ( $V_{CC} = +5\text{ V}$ ,  $V_{AGC} = +3.0\text{ V}$ )





All performance data measured using application circuit with input photodiode, as shown in Figure 16.

**Figure 8: Gain Flatness To Best Fit Line over Temperature**  
 (V<sub>CC</sub> = + 5 V, V<sub>AGC</sub> = +1.6 V)



**Table 6: Gain Flatness to Best Fit Line**  
 (V<sub>AGC</sub> = +1.6 V)

Temp (°C)	Tilt (dB)	Flatness (dB)
115	3.8	2.3
100	4.1	1.9
60	4.7	0.9
40	5.1	1.2
15	5.5	1.6
-5	5.8	1.9
-25	6	1.9
-35	6	1.6

The best fit line is calculated using the least mean squares method:

$$y = m \cdot x + b$$

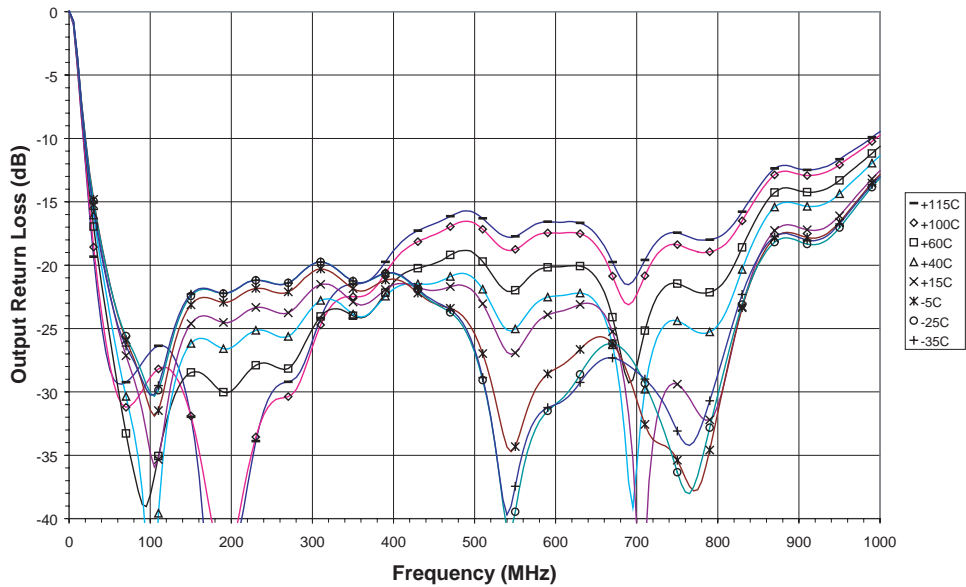
$$m = \frac{\sum(x \cdot y) - \frac{\sum x \cdot \sum y}{n}}{\sum x^2 - \frac{(\sum x)^2}{n}}$$

$$b = \frac{\sum y}{n} - m \cdot \frac{\sum x}{n}$$

*n* = number of points

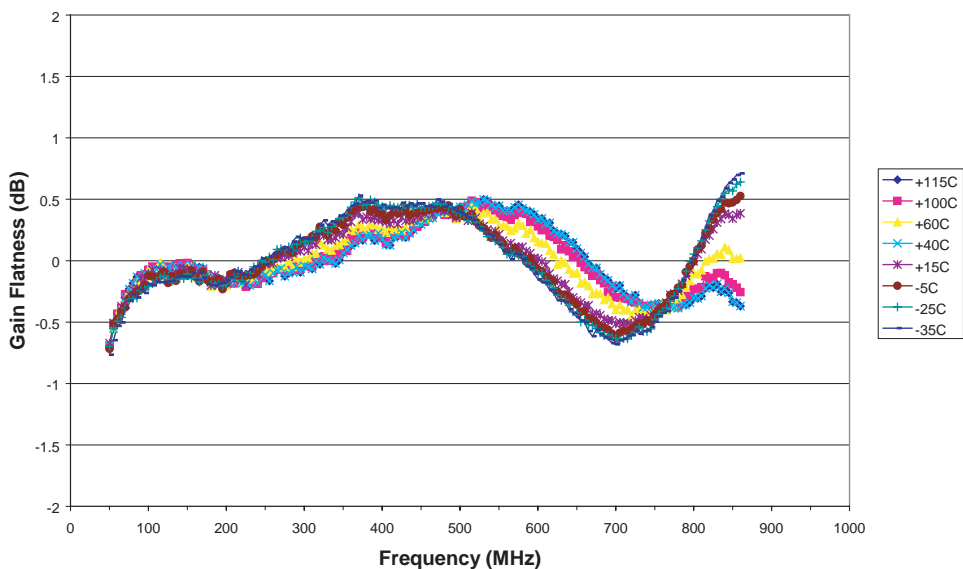
All performance data measured using application circuit with input photodiode, as shown in Figure 16.

**Figure 9: Output Return Loss over Temperature**  
 ( $V_{CC} = +5\text{ V}$ ,  $V_{AGC} = +1.6\text{ V}$ )



All performance data measured using application circuit with input photodiode, as shown in Figure 16.

**Figure 10: Gain Flatness To Best Fit Line vs. Frequency over Temperature**  
( $V_{CC} = +5\text{ V}$ ,  $V_{AGC} = 0\text{ V}$ )



**Table 7: Gain Flatness to Best Fit Line**  
( $V_{AGC} = 0\text{ V}$ )

Temp (°C)	Tilt (dB)	Flatness (dB)
115	5.4	1.2
100	5.7	1.2
60	6.1	1.1
40	6.3	1.1
15	6.6	1.1
-5	6.8	1.2
-25	6.9	1.3
-35	7	1.5

The best fit line is calculated using the least mean squares method:

$$y = m \cdot x + b$$

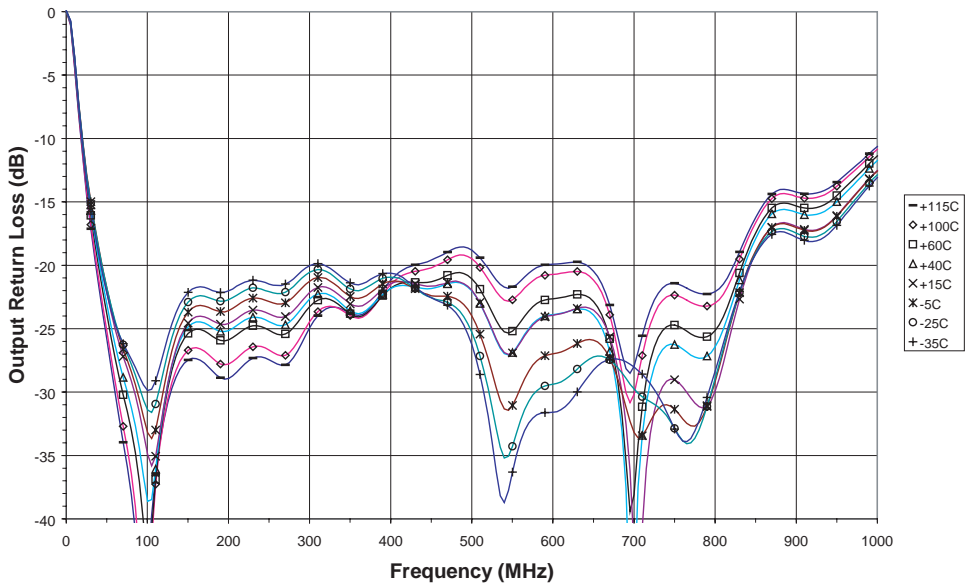
$$m = \frac{\sum(x \cdot y) - \frac{\sum x \cdot \sum y}{n}}{\sum x^2 - \frac{(\sum x)^2}{n}}$$

$$b = \frac{\sum y}{n} - m \cdot \frac{\sum x}{n}$$

$n = \text{number of points}$

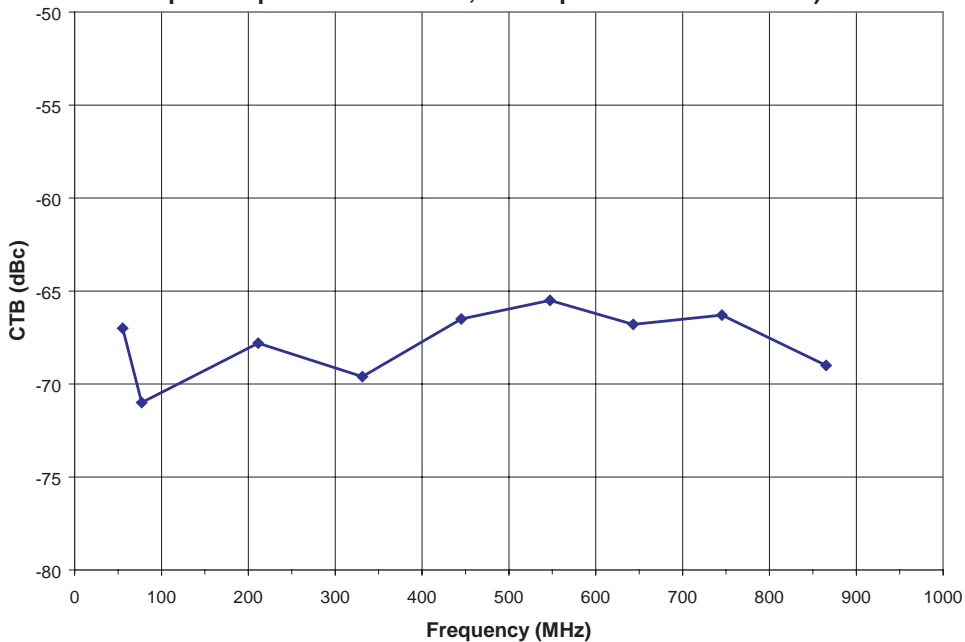
All performance data measured using application circuit with input photodiode, as shown in Figure 16.

**Figure 11: Output Return Loss over Temperature**  
 ( $V_{CC} = +5\text{ V}$ ,  $V_{AGC} = 0\text{ V}$ )

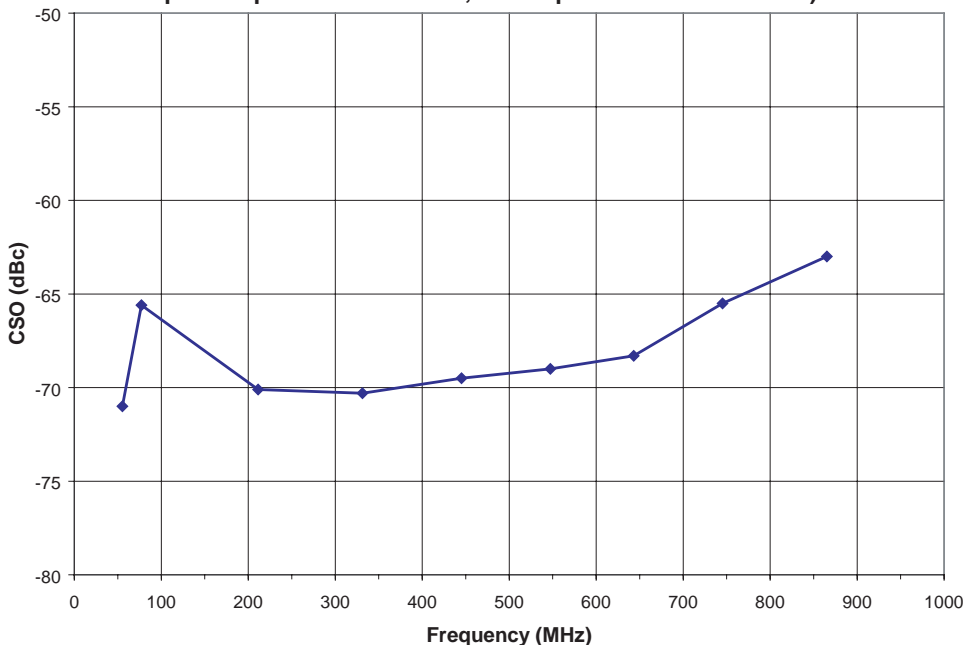


All performance data measured using application circuit with input photodiode, as shown in Figure 16.

**Figure 12: CTB vs. Frequency**  
 (T<sub>A</sub> = +25 °C, V<sub>CC</sub> = + 5 V, 132 Analog Channel Loading,  
 Optical Input Power = 0 dBm, RF Output Power = +18 dBmV)

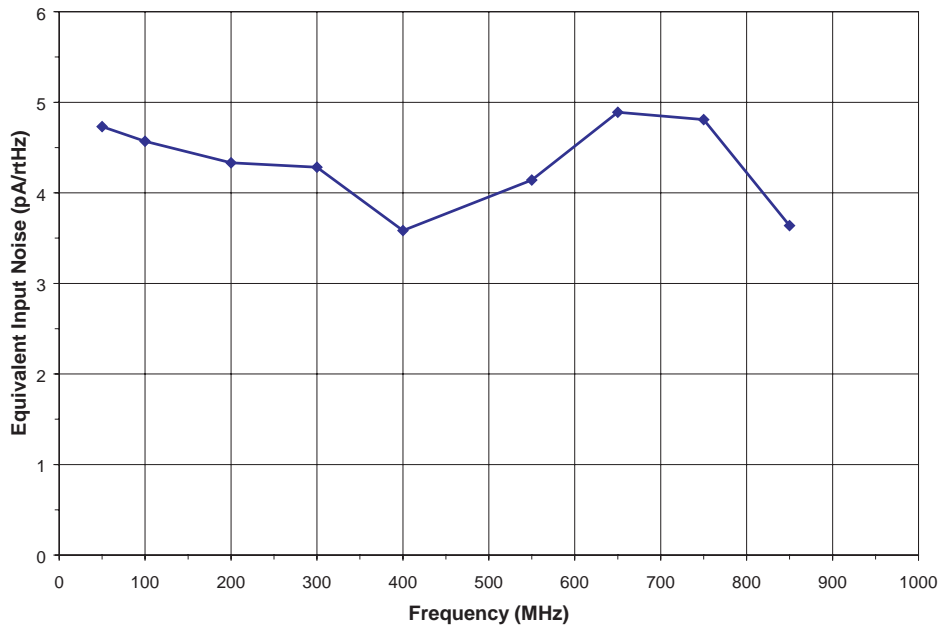


**Figure 13: CSO vs. Frequency**  
 (T<sub>A</sub> = +25 °C, V<sub>CC</sub> = + 5 V, 132 Analog Channel Loading,  
 Optical Input Power = 0 dBm, RF Output Power = +18 dBmV)

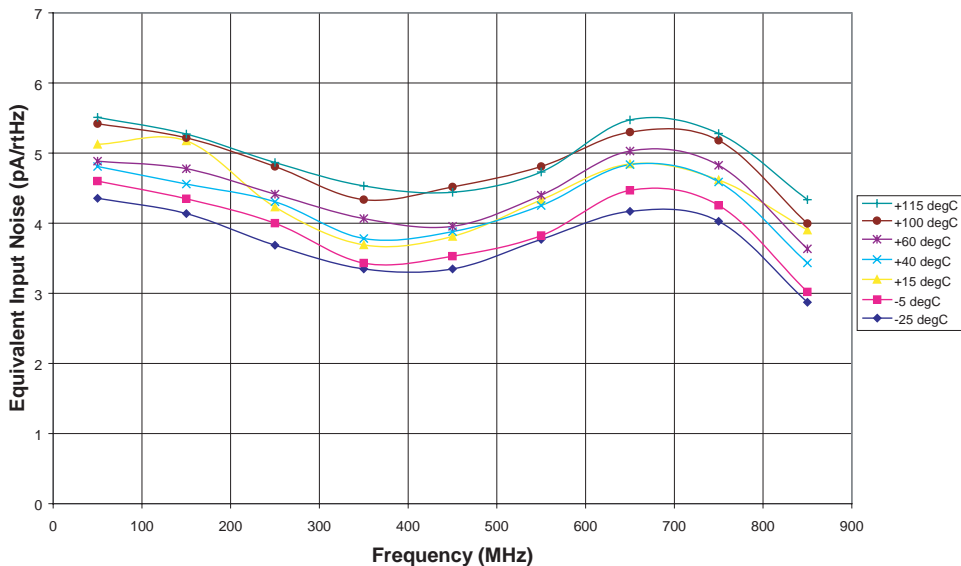


All performance data measured using application circuit with input photodiode, as shown in Figure 16.

**Figure 14: Equivalent Input Noise vs. Frequency**  
 (TA = +25 °C, VCC = +5 V, VAGC = +3.0)



**Figure 15: Equivalent Input Noise over Temperature**  
 (VCC = +5 V, VAGC = +3.0)



APPLICATION INFORMATION

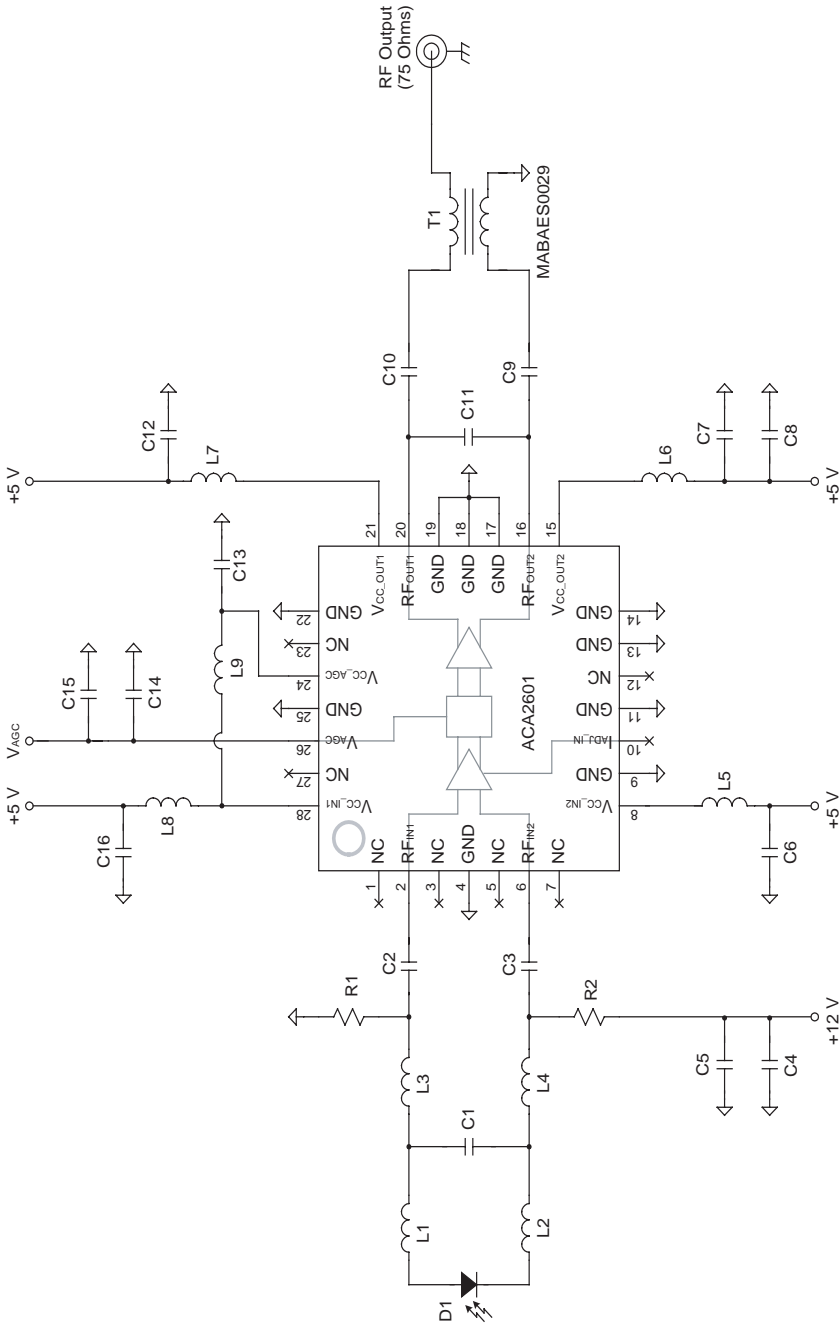


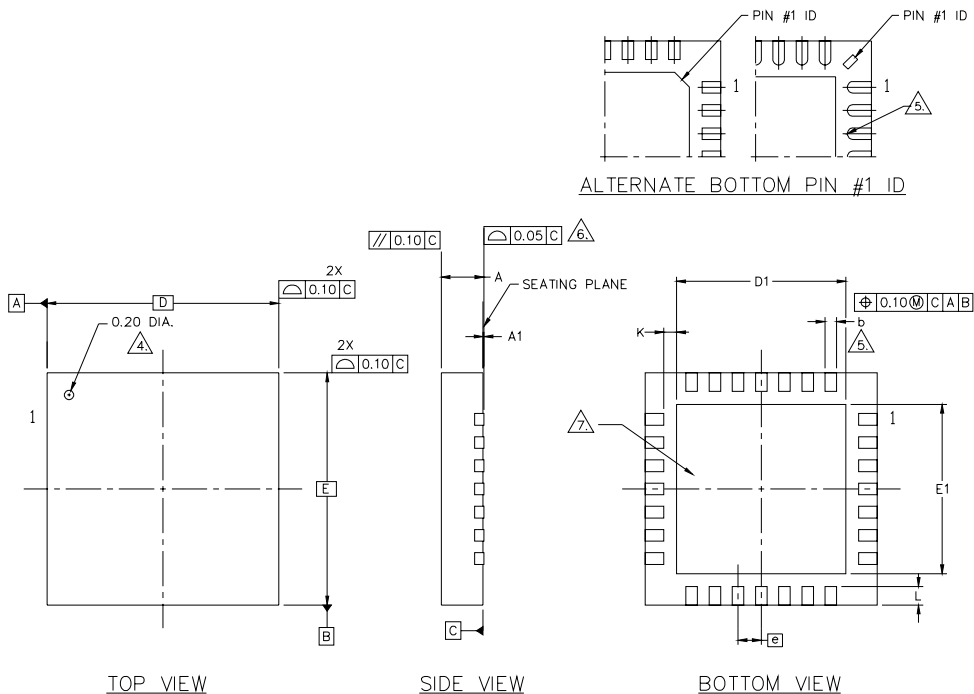
Figure 16: Application Circuit with Input Photodiode

Table 8: Evaluation Board Parts List

REF	DESCRIPTION	QTY	VENDOR	VENDOR PART NO.
C11	0.5 pF; 0603 Cap	1	Murata Electronics	GRM1885C1HR50CZ01D
C1	1 pF; 0603 Cap	1	Murata Electronics	GRM1885C1H1R0CZ01D
C9, C10	180 pF; 0603 Cap	2	TDK Corporation	C1608C0G1H181J
C2, C3	470 pF; 0603 Cap	2	Murata Electronics	GRM155R71H471KA01D
C5	1000 pF; 0603 Cap	1	Murata Electronics	GRM1885C1H102JA01D
C6, C7, C12, C13, C15, C16	0.01 $\mu$ F; 0603 Cap	6	Murata Electronics	GRM1885C1HR50CZ01D
C4	0.1 $\mu$ F; 0603 Cap	1	Murata Electronics	GRM188F51C104ZA01D
C14	1 $\mu$ F; 0603 Cap	1	Murata Electronics	GRM188R61C105KA93D
C8	47 $\mu$ F; Elect. Cap 25 V	1	Panasonic-ECG	ECA-1EM470B
L1, L2, L3, L4	27 nH; 0603 Ind	4	Coilcraft	0603CS-27NXJB
L5, L8	180 nH; 0603 Ind	2	Coilcraft	0603CS-R18XJB
L6, L7	270 nH; 0603 Ind	2	Coilcraft	0603CS-R27XJB
L9	820 nH; 1008 Ind	1	Panasonic	ELJ-NCR82JF
R1, R2	1 k $\Omega$ ; 0603 Res	2	Panasonic-ECG	ERJ-3EKF1001V
T1	1:1 Balun Transformer; 0603 Cap	1	M/A-COM	MABAES0029
D1	Analog Photodiode	1	ANADIGICS	PD070-HL1-300 or PD070-HL2-300
Connector	75 $\Omega$ N Male Panel Mount	1	Pasternack Enterprises	PE4504



PACKAGE OUTLINE



S V W G	DIMENSIONS—MM		N <sub>o</sub>	T <sub>ε</sub>	S V W G	DIMENSIONS—INCHES		N <sub>o</sub>	T <sub>ε</sub>
	MIN.	MAX.				MIN.	MAX.		
A	0.80	1.00	A		0.031	0.039			
A1	0.00	0.05	A1		0.000	0.002			
b	0.18	0.30	b		0.007	0.012			
D	5.00 BSC		D		0.197 BSC				
D1	3.40	3.80	D1		0.134	0.149			
E	5.00 BSC		E		0.197 BSC				
E1	3.40	3.80	E1		0.134	0.149			
Ⓞ	0.50 BSC		Ⓞ		0.020 BSC				
K	0.20 MIN.		K		0.007 MIN.				
L	0.35	0.57	L		0.014	0.022			

NOTES :

- ALL DIMENSIONS ARE IN MILLIMETERS.
- MAX. PACKAGE WARPAGE IS 0.05 mm.
- MAXIMUM ALLOWABLE BURRS IS 0.076 mm IN ALL DIRECTIONS.
- PIN #1 ID ON TOP WILL BE LASER MARKED.
- DIMENSION b APPLIES TO METALLIZED TERMINAL AND IS MEASURED BETWEEN 0.25 AND 0.30mm FROM TERMINAL TIP. RADIUS OPTIONAL. DIMENSION b SHOULD NOT BE MEASURED IN RADIUS AREA.
- BILATERAL COPLANARITY ZONE APPLIES TO THE EXPOSED HEAT SINK SLUG AS WELL AS THE TERMINALS.
- REFERENCE JEDEC OUTLINE MO-220.

Figure 17: S29 Package Outline - 28 Pin 5 mm x 5 mm x 1 mm QFN



NOTES

**ORDERING INFORMATION**

ORDER NUMBER	TEMPERATURE RANGE	PACKAGE DESCRIPTION	COMPONENT PACKAGING
ACA2601RS29P8	-40 °C to +110 °C	RoHS-Compliant 28 Pin QFN 5 mm x 5 mm x 1 mm	Tape and Reel, 2500 pieces per Reel



**ANADIGICS, Inc.**  
141 Mount Bethel Road  
Warren, New Jersey 07059, U.S.A.  
Tel: +1 (908) 668-5000  
Fax: +1 (908) 668-5132

URL: <http://www.anadigics.com>  
E-mail: [Mktg@anadigics.com](mailto:Mktg@anadigics.com)

**IMPORTANT NOTICE**

ANADIGICS, Inc. reserves the right to make changes to its products or to discontinue any product at any time without notice. The product specifications contained in Advanced Product Information sheets and Preliminary Data Sheets are subject to change prior to a product's formal introduction. Information in Data Sheets have been carefully checked and are assumed to be reliable; however, ANADIGICS assumes no responsibilities for inaccuracies. ANADIGICS strongly urges customers to verify that the information they are using is current before placing orders.

**WARNING**

ANADIGICS products are not intended for use in life support appliances, devices or systems. Use of an ANADIGICS product in any such application without written consent is prohibited.