

NOTES

1. MATERIAL:

- CAGE: NICKEL SILVER, THICKNESS: 0.25mm
- CONNECTOR HOUSING: GLASS FILLED LIQUID CRYSTAL POLYMER (LCP), UL 94V-0, COLOR: BLACK
- OVERMOLD TERMINAL HOUSING: GLASS FILLED LIQUID CRYSTAL POLYMER (LCP), UL 94V-0, COLOR: BLACK
- TERMINALS: TIN BRASS
- LIGHTPIPE HOUSING: ZINC
- LIGHTPIPER: POLYCARBONATE, COLOR: CLEAR

2. FINISHES:

TERMINALS: CONTACT AREA: 0.76 MICROMETERS MINIMUM HARD GOLD OVER 1.27 MICROMETERS MINIMUM NICKEL.

COMPLIANT TAIL: 0.76 TO 1.52 MICROMETERS MATTE TIN OVER 0.76 MICROMETERS MINIMUM NICKEL.

LIGHTPIPE HOUSING: 80 MICROMETERS MINIMUM NICKEL OVER COPPER

3. REFER TO PS-75310-001 PRODUCT SPEC FOR ALL ELECTRICAL, MECHANICAL AND ENVIRONMENTAL SPECIFICATIONS.

4. LIGHT PIPE PAD LAYOUT IS FOR 0805 LOW-PROFILE LED PACKAGE, FOR OTHER RECOMMENDED LAYOUTS REFER TO MOLEX'S REPORT TS-75310-001.

5. REFER TO PK-75450-001 FOR ALL PACKAGING SPECIFICATIONS.

6. ALL EXTERIOR SURFACES TO BE CLASS "B" SURFACE EXCEPT THE UNDER SIDE OF THE CAGE (CLASS "C") WHERE THE PCB WOULD BE LOCATED AND AS OTHERWISE NOTED.

THE SURFACES TO CONFORM TO THE MOLEX COSMETIC DOC PS-45499-002.

7. REFER TO AS-76090-001 FOR HIGH SPEED ROUTING RECOMMENDATIONS.

8. DATE CODE LOCATION IS SHOWN ABOVE.

DATE CODE FORMAT: DDDY MX A1

DDD = DAY OF THE YEAR

Y = YEAR

MX = MOLEX

A = ALPHA CHARACTER - INDICATES MANUFACTURING LINE

1 = NUMERIC CHARACTER - INDICATES PRODUCTION SHIFT

PART NUMBER	LIGHT PIPE CONFIGURATION - SEE SHEET 2	CAGE PLATING
76046-5901	4 LIGHT PORTS	NONE
	INNER 2 PORTS	NONE
	OUTER 2 PORTS	NONE

INITIAL RELEASE EC NO: UCP2014-0581 DRWN:BBARKER 2013/08/06 CHKD: APPR:SMILLER 2013/12/20	DESCRIPTION 2013/12/20	QUALITY SYMBOLS	GENERAL TOLERANCES (UNLESS SPECIFIED)		DIMENSION STYLE MM ONLY		SCALE 3:1	DESIGN UNITS METRIC	THIRD ANGLE PROJECTION	
		▽=0	mm	INCH	DRAWN BY BBARKER	DATE 2013/08/06	TITLE STACKED SFP+ 2X4 ASS'Y NO GASKET/FLANGE WITH LIGHTPIPER molex	DOCUMENT NO. RSD-76046-5900	SHEET NO. 1 OF 4	
		▽=0	4 PLACES ± --- ± ---	3 PLACES ± --- ± ---	CHECKED BY TIBARRA	DATE 2013/08/08				
		▽=0	2 PLACES ± 0.13 ± ---	1 PLACE ± 0.25 ± ---	APPROVED BY SMILLER	DATE 2013/12/20				
▽=0	0 PLACE ± ±	ANGULAR ± 5 °								
A	REV	DRAFT WHERE APPLICABLE MUST REMAIN WITHIN DIMENSIONS		SIZE C	THIS DRAWING CONTAINS INFORMATION THAT IS PROPRIETARY TO MOLEX INCORPORATED AND SHOULD NOT BE USED WITHOUT WRITTEN PERMISSION					

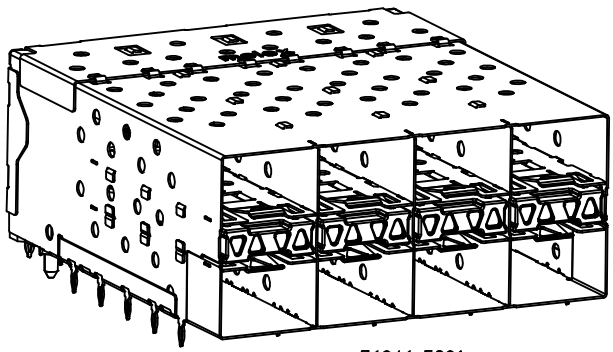

76046-5901
WITH INNER & OUTER LIGHTPIPE PORTS

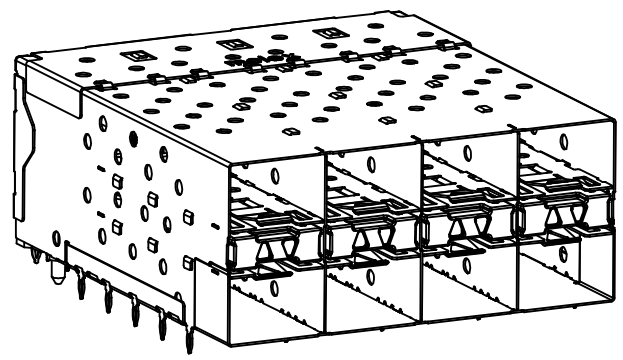

WITH INNER LIGHTPIPE PORTS

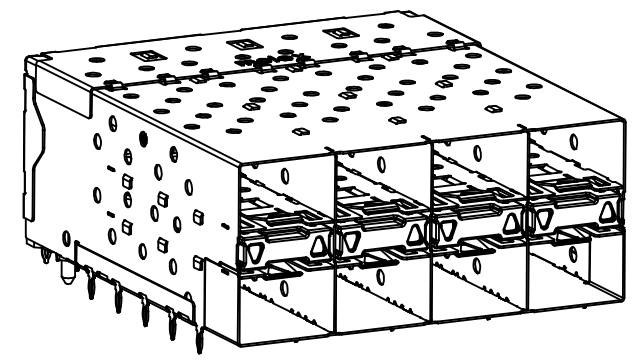

WITH OUTER LIGHTPIPE PORTS

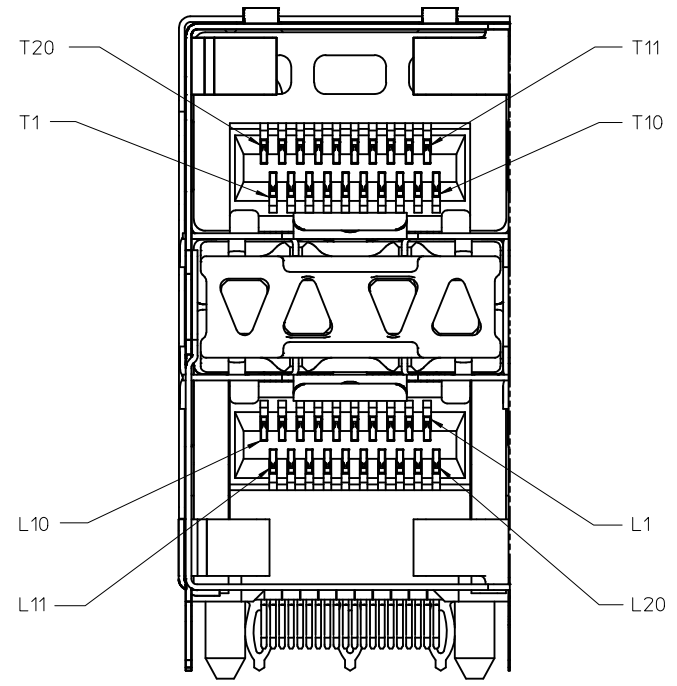
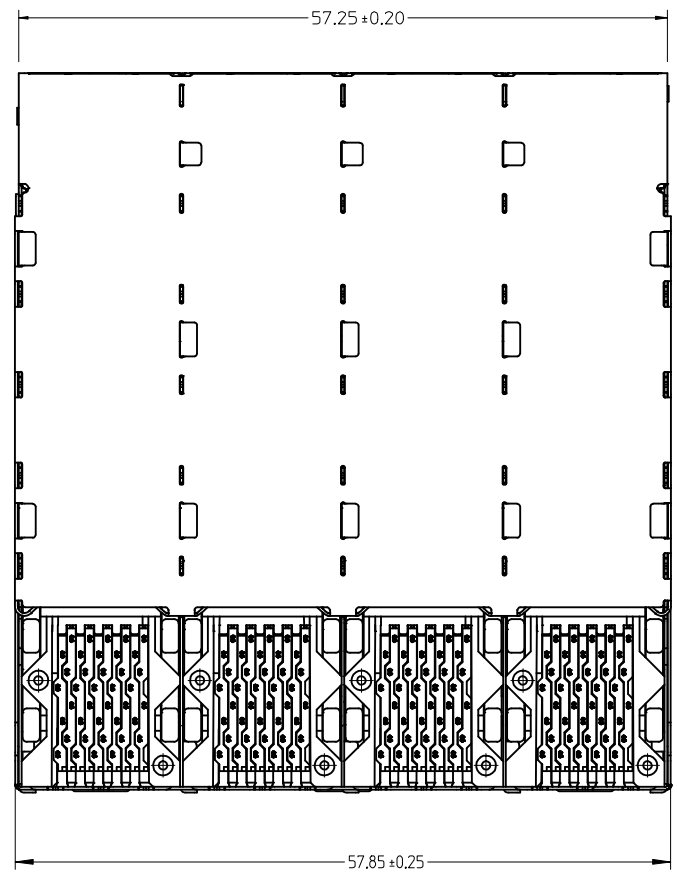

DETAIL B SCALE 6:1
CIRCUIT NUMBERING AND LIGHTPIPE IDENTIFICATION

SEE SHEET 1 EC NO: UCP2014-0581 DRWN:BBARKER 2013/08/06 CHKD: APPR:SMILLER 2013/12/20 REVISIONS A	QUALITY SYMBOLS ▽=0 ▽=0 ▽=0	GENERAL TOLERANCES (UNLESS SPECIFIED) mm INCH 4 PLACES ± --- ± --- 3 PLACES ± --- ± --- 2 PLACES ± 0.13 ± --- 1 PLACE ± 0.25 ± --- 0 PLACE ± ± ANGULAR ± 5 ° DRAFT WHERE APPLICABLE MUST REMAIN WITHIN DIMENSIONS	DIMENSION STYLE MM ONLY DRAWN BY DATE BBARKER 2013/08/06 CHECKED BY DATE TIBARRA 2013/08/08 APPROVED BY DATE SMILLER 2013/12/20 MATERIAL NO. SEE TBL, SHT 1	SCALE 3:1 DESIGN UNITS METRIC THIRD ANGLE PROJECTION STACKED SFP+ 2X4 ASS'Y NO GASKET/FLANGE WITH LIGHTPIPER molex DOCUMENT NO. RSD-76046-5900 SHEET NO. 2 OF 4
	THIS DRAWING CONTAINS INFORMATION THAT IS PROPRIETARY TO MOLEX INCORPORATED AND SHOULD NOT BE USED WITHOUT WRITTEN PERMISSION			

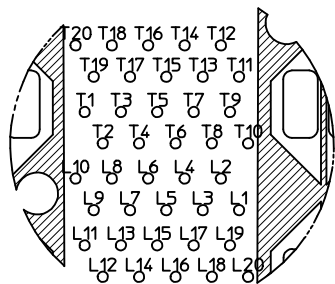

CIRCUIT NUMBERING
COMPONENT SIDE OF BOARD

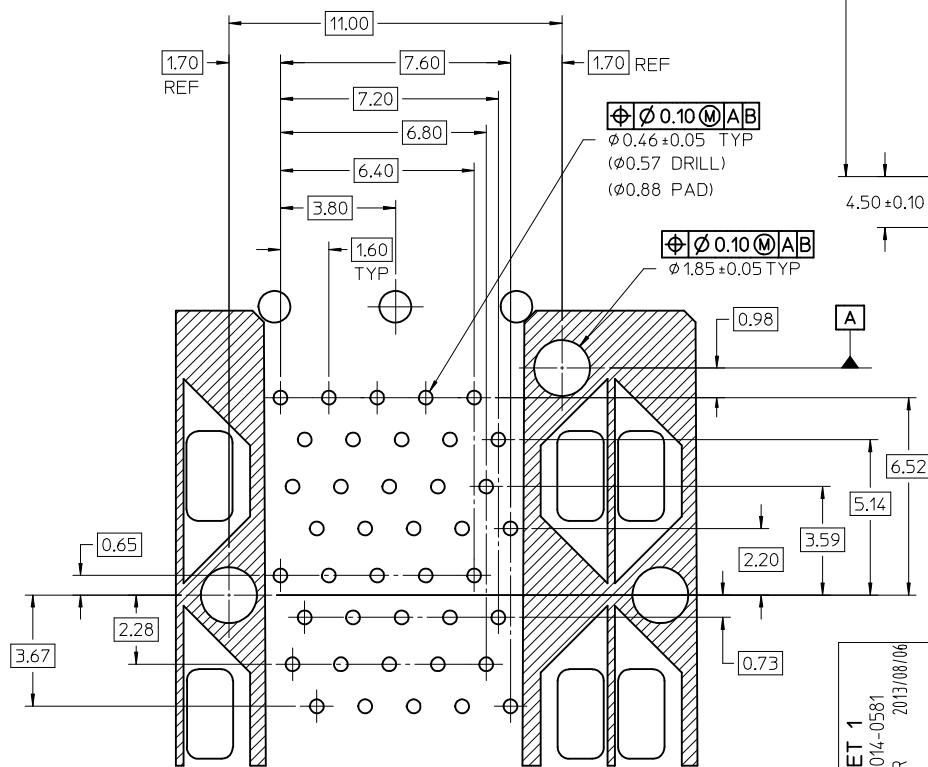

DETAIL A
SCALE 8:1

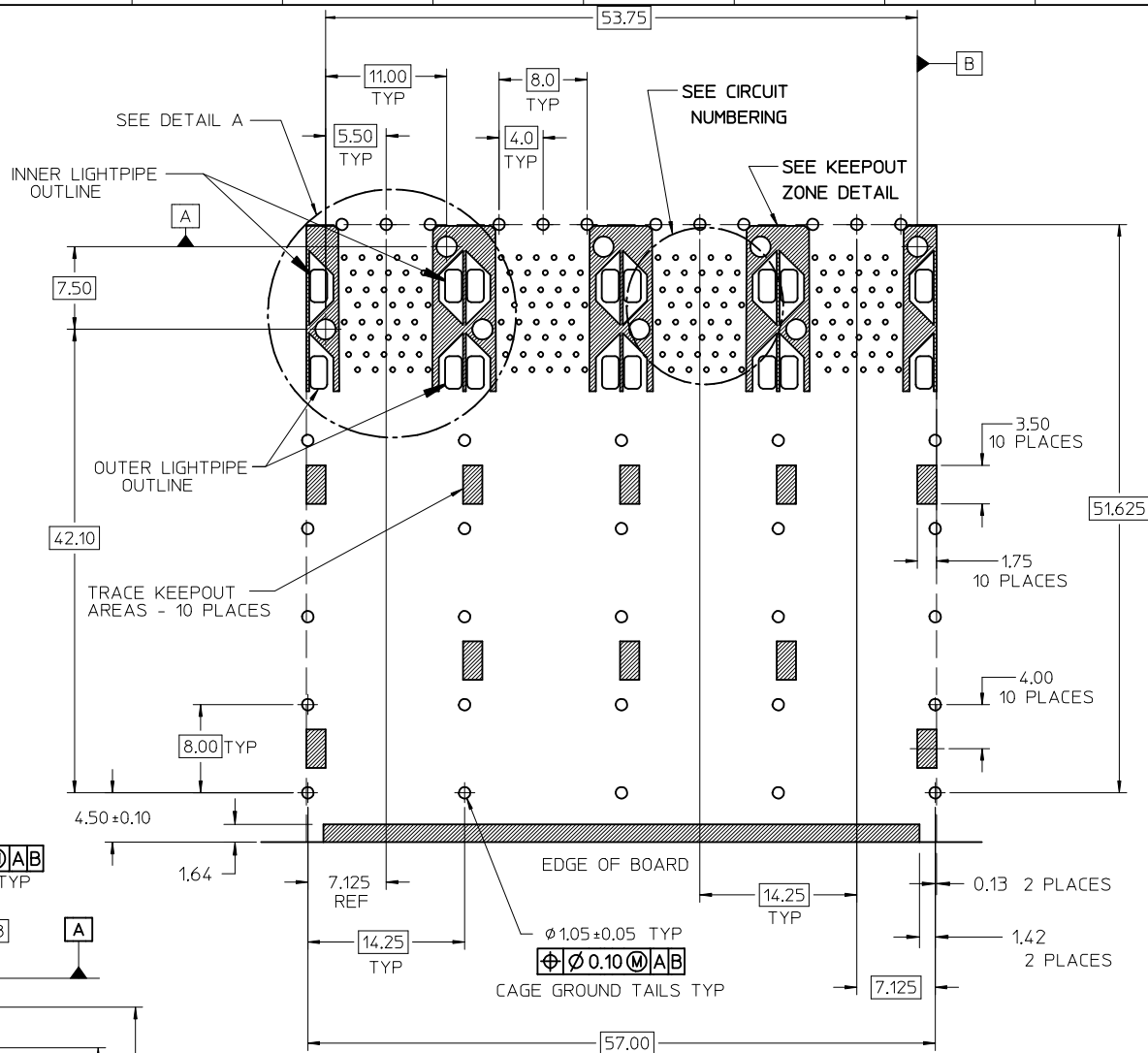

RECOMMENDED PCB LAYOUT - COMPONENT SIDE
MINIMUM PCB THICKNESS OF 157MM
THE ENTIRE AREA OF THE CONNECTOR FOOTPRINT
TO BE CONSIDERED THE KEEP OUT AREA INDICATED
BY THE DASHED LINE

SEE SHEET 1 EC NO: UCP2014-0581 DRAWN: BBARKER 2013/08/06 CHKD: APPR: MILLER 2013/12/20	QUALITY SYMBOLS	GENERAL TOLERANCES (UNLESS SPECIFIED)	DIMENSION STYLE MM ONLY	SCALE 3:1	DESIGN UNITS METRIC	THIRD ANGLE PROJECTION
	▽=0 ▽=0 ▽=0	mm INCH	DRAWN BY DATE BBARKER 2013/08/06	TITLE STACKED SFP+ 2X4 ASS'Y NO GASKET/FLANGE WITH LIGHTPIPES	DOCUMENT NO. RSD-76046-5900	SHEET NO. 3 OF 4
REV A	DESCRIPTION	ANGULAR ± 5°	APPROVED BY DATE SMILLER 2013/12/20	THIS DRAWING CONTAINS INFORMATION THAT IS PROPRIETARY TO MOLEX INCORPORATED AND SHOULD NOT BE USED WITHOUT WRITTEN PERMISSION		

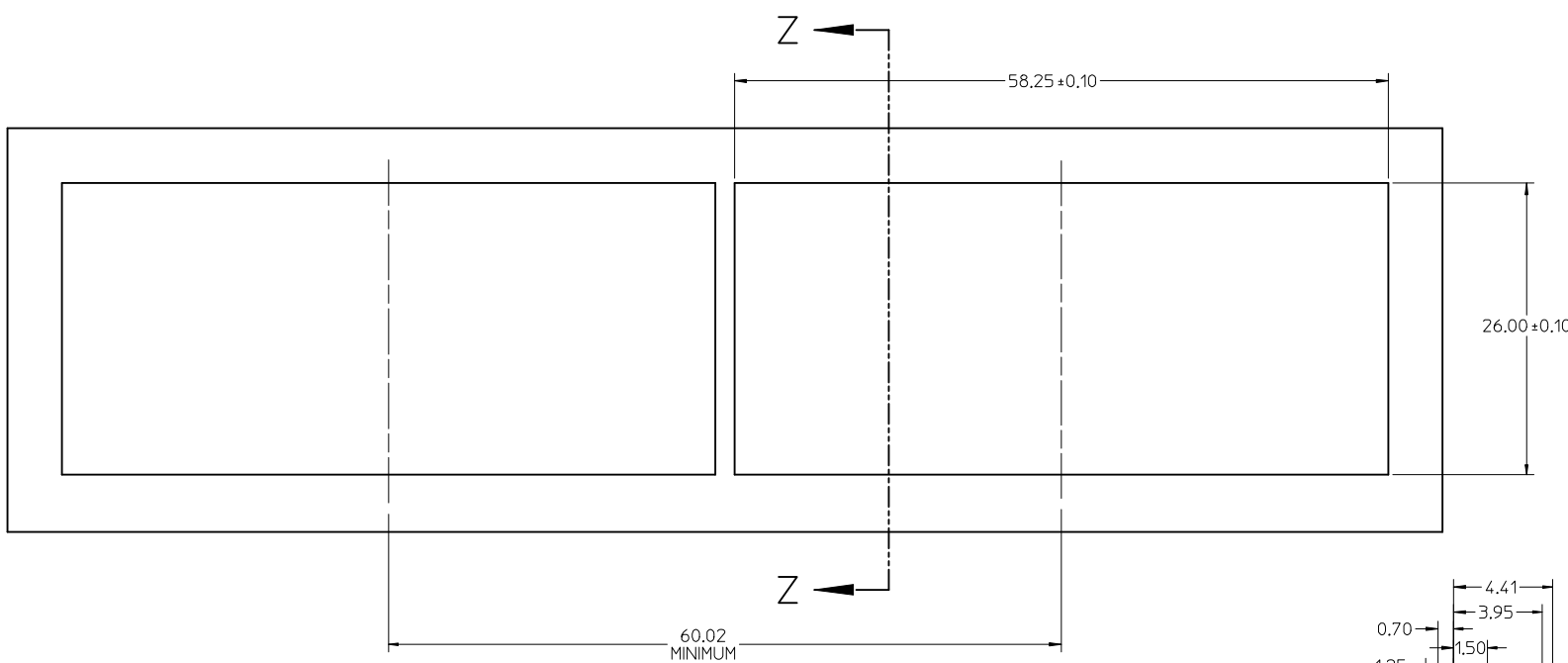

BEZEL CUTOUT CENTER SPACING DETAIL
BEZEL THICKNESS 0.8-2.6

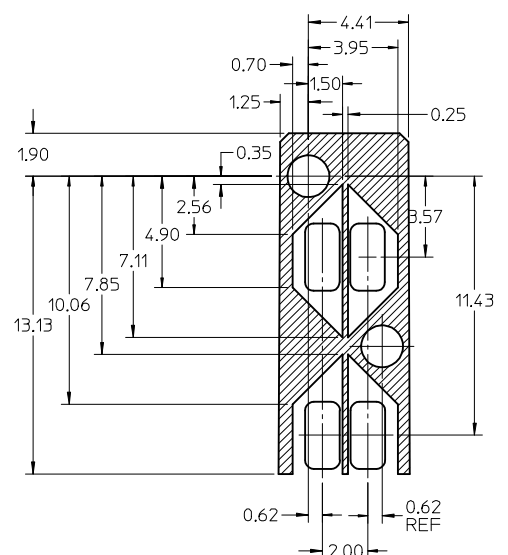

KEEP OUT ZONE DETAIL - LIGHTPIPE LOCATION AND OTHER ZONES
SCALE 6:1

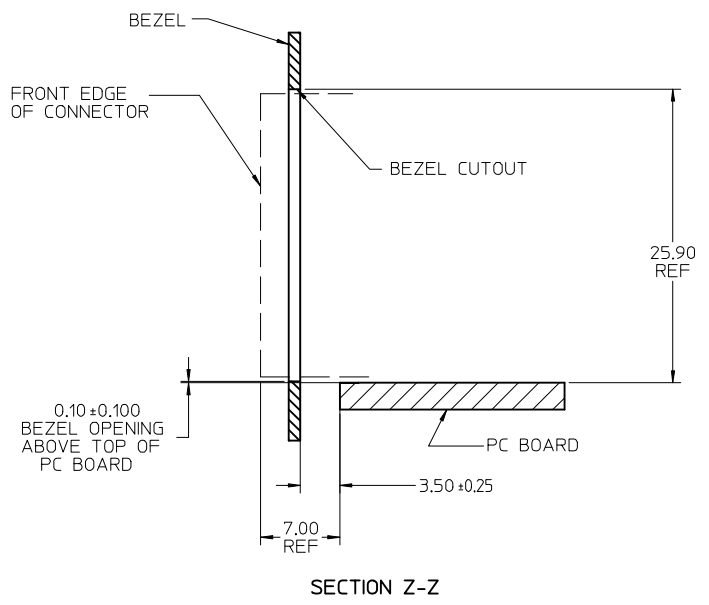

SECTION Z-Z

SEE SHEET 1 EC NO: UCP2014-0581 DRWN:BBARKER 2013/08/06 CHKD: APPR:SMILLER 2013/12/20	QUALITY SYMBOLS ▽=0 ▽=0 ▽=0	GENERAL TOLERANCES (UNLESS SPECIFIED)		DIMENSION STYLE MM ONLY	SCALE 3:1	DESIGN UNITS METRIC	THIRD ANGLE PROJECTION	
		mm	INCH	DRAWN BY BBARKER	DATE 2013/08/06	TITLE STACKED SFP+ 2X4 ASS'Y NO GASKET/FLANGE WITH LIGHTPIPES		
A	DESCRIPTION REV	4 PLACES	± ---	± ---	CHECKED BY TIBARRA	DATE 2013/08/08	DOCUMENT NO. RSD-76046-5900	SHEET NO. 4 OF 4
		3 PLACES	± ---	± ---	APPROVED BY SMILLER	DATE 2013/12/20		
		2 PLACES	± 0.13	± ---	MATERIAL NO.			
		1 PLACE	± 0.25	± ---	SIZE SEE TBL, SHT 1			
		0 PLACE	±	±	THIS DRAWING CONTAINS INFORMATION THAT IS PROPRIETARY TO MOLEX. INCORPORATED AND SHOULD NOT BE USED WITHOUT WRITTEN PERMISSION			
		ANGULAR ± 5 °						
		DRAFT WHERE APPLICABLE MUST REMAIN WITHIN DIMENSIONS						

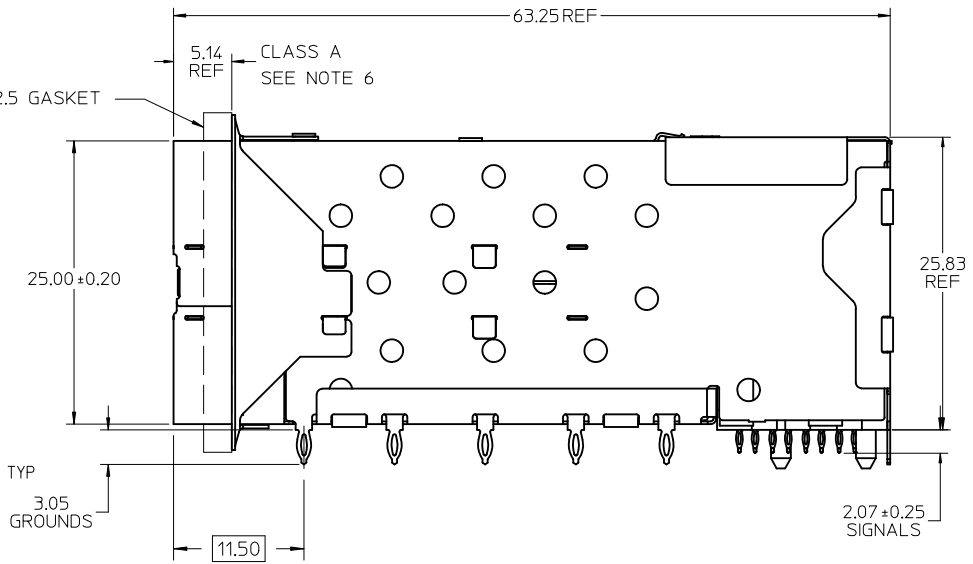
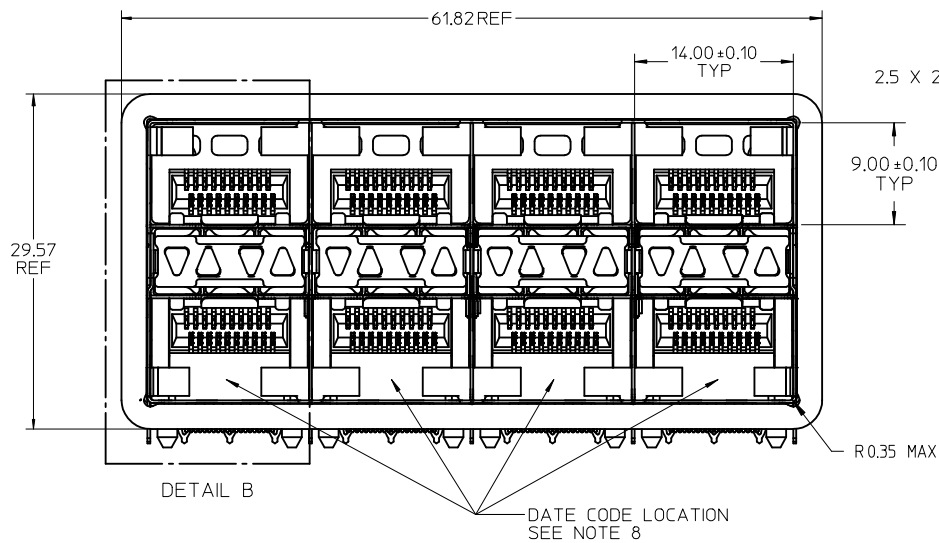

NOTES

1. MATERIAL:

- CAGE: NICKEL SILVER, THICKNESS: 0.25mm
- CONNECTOR HOUSING: GLASS FILLED LIQUID CRYSTAL POLYMER (LCP), UL 94V-0, COLOR: BLACK
- OVERMOLD TERMINAL HOUSING: GLASS FILLED LIQUID CRYSTAL POLYMER (LCP), UL 94V-0, COLOR: BLACK
- TERMINALS: TIN BRASS
- EMI GASKET: CONDUCTIVE ELASTOMER
- LIGHTPIPE HOUSING: ZINC
- LIGHTPIPES: POLYCARBONATE, COLOR: CLEAR

2. FINISHES:

- TERMINALS: CONTACT AREA: 0.76 MICROMETERS MINIMUM HARD GOLD OVER 1.27 MICROMETERS MINIMUM NICKEL.
- COMPLIANT TAIL - MATTE TIN/LEAD OPTION: 0.76 TO 1.52 MICROMETERS 90/10 MATTE TIN-LEAD OVER 0.76 MICROMETERS MINIMUM NICKEL.
- COMPLIANT TAIL - MATTE TIN OPTION: 0.76 TO 1.52 MICROMETERS MATTE TIN OVER 0.76 MICROMETERS MINIMUM NICKEL.
- LIGHTPIPE HOUSING: 80 MICROMETERS MINIMUM NICKEL OVER COPPER

- 3. REFER TO PS-75310-001 PRODUCT SPEC FOR ALL ELECTRICAL, MECHANICAL AND ENVIRONMENTAL SPECIFICATIONS.
- 4. LIGHT PIPE PAD LAYOUT IS FOR 0805 LOW-PROFILE LED PACKAGE, FOR OTHER RECOMMENDED LAYOUTS REFER TO MOLEX'S REPORT TS-75310-001.
- 5. REFER TO PK-75450-001 FOR ALL PACKAGING SPECIFICATIONS.
- 6. ALL EXTERIOR SURFACES TO BE CLASS 'B' SURFACE EXCEPT THE UNDER SIDE OF THE CAGE WHERE THE PCB WOULD BE LOCATED AND AS NOTED. THE SURFACES TO CONFORM TO THE MOLEX COSMETIC DOC PS-45499-002.
- 7. REFER TO AS-76090-001 FOR HIGH SPEED ROUTING RECOMMENDATIONS.
- 8. DATE CODE LOCATION IS SHOWN ABOVE.

DATE CODE FORMAT: DDDY MX A1

DDD = DAY OF THE YEAR

Y = YEAR

MX = MOLEX

A = ALPHA CHARACTER - INDICATES MANUFACTURING LINE

1 = NUMERIC CHARACTER - INDICATES PRODUCTION SHIFT

PART NUMBER	DESCRIPTION	VIEW	COMPLIANT TAIL PLATING	CAGE PLATING
760920001	4 LIGHT PORTS	SEE PG 2	MATTE TIN / LEAD	N/A
760920002	INNER 2 PORTS	SEE PG 2	MATTE TIN / LEAD	N/A
760920003	OUTER 2 PORTS	SEE PG 2	MATTE TIN / LEAD	N/A
760925001	4 LIGHT PORTS	SEE PG 2	MATTE TIN	N/A
760925002	INNER 2 PORTS	SEE PG 2	MATTE TIN	N/A
760925003	OUTER 2 PORTS	SEE PG 2	MATTE TIN	N/A

ADD NOTE 7 & 8 EC NO: UCP2011-2594 DR: WIMOLFE 2011/02/28 CHK: BBARKER 2011/02/28 APPR: SMILLER 2011/09/20	DESCRIPTION QUALITY SYMBOLS ▽=0 ▽=0 ▽=0	GENERAL TOLERANCES (UNLESS SPECIFIED)		DIMENSION STYLE MM ONLY		SCALE 3:1	DESIGN UNITS METRIC	THIRD ANGLE PROJECTION																
		<table border="1"> <thead> <tr> <th></th> <th>mm</th> <th>INCH</th> </tr> </thead> <tbody> <tr> <td>4 PLACES</td> <td>± ---</td> <td>± ---</td> </tr> <tr> <td>3 PLACES</td> <td>± ---</td> <td>± ---</td> </tr> <tr> <td>2 PLACES</td> <td>± 0.13</td> <td>± ---</td> </tr> <tr> <td>1 PLACE</td> <td>± 0.25</td> <td>± ---</td> </tr> </tbody> </table>			mm	INCH	4 PLACES	± ---	± ---	3 PLACES	± ---	± ---	2 PLACES	± 0.13	± ---	1 PLACE	± 0.25	± ---	DRAWN BY DATE JLONG 01-26-2007		TITLE STACKED SFP+ 2X4 ASS'Y WITH ELASTOMERIC GASKET AND LIGHTPIPES			
			mm	INCH																				
		4 PLACES	± ---	± ---																				
3 PLACES	± ---	± ---																						
2 PLACES	± 0.13	± ---																						
1 PLACE	± 0.25	± ---																						
ANGULAR ± 5 °		CHECKED BY DATE MSANDBERG 01-26-2007		APPROVED BY DATE RNELSON 01-26-2007																				
DRAFT WHERE APPLICABLE MUST REMAIN WITHIN DIMENSIONS		SEE TABLE		MATERIAL NO.		DOCUMENT NO.		SHEET NO.																
						MOLEX INCORPORATED		SD-76092-001																
				SIZE C		THIS DRAWING CONTAINS INFORMATION THAT IS PROPRIETARY TO MOLEX INCORPORATED AND SHOULD NOT BE USED WITHOUT WRITTEN PERMISSION		1 OF 4																

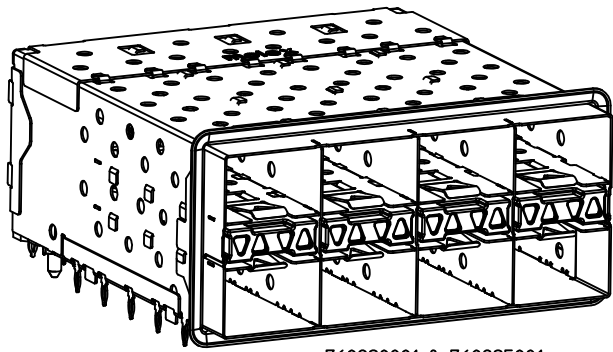

760920001 & 760925001
WITH INNER & OUTER LIGHTPIPE PORTS

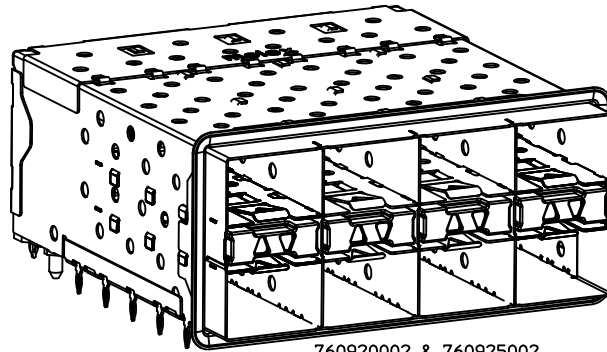

760920002 & 760925002
WITH INNER LIGHTPIPE PORTS

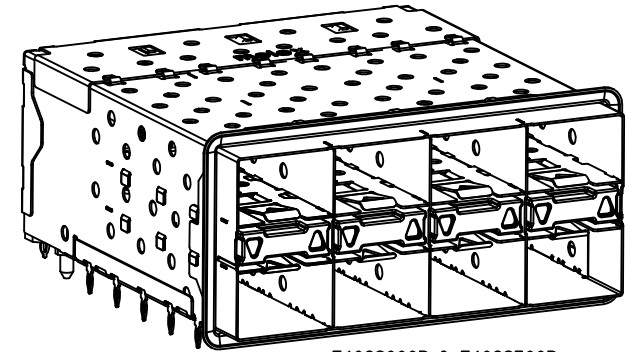

760920003 & 760925003
WITH OUTER LIGHTPIPE PORTS

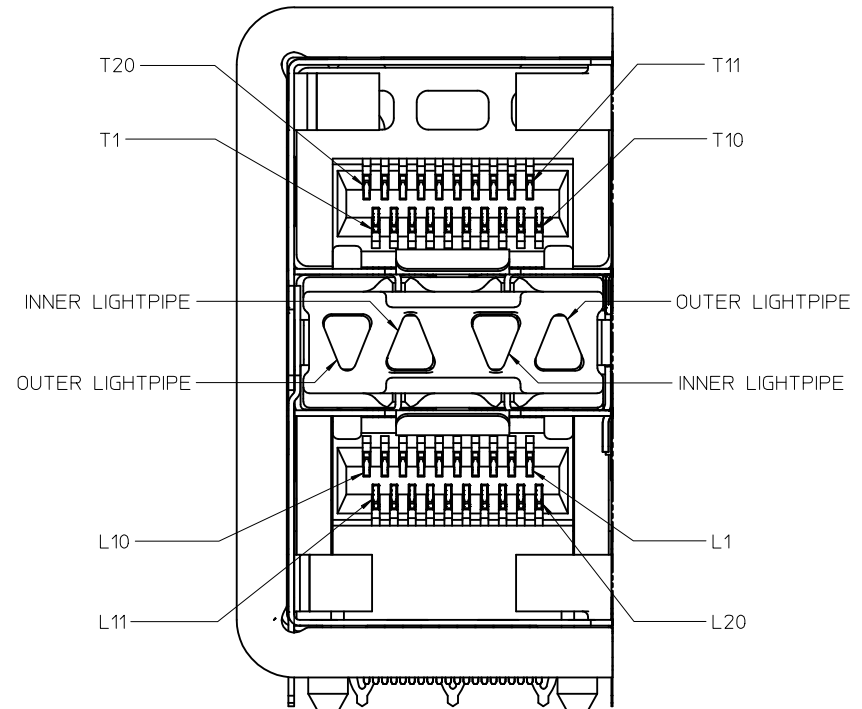
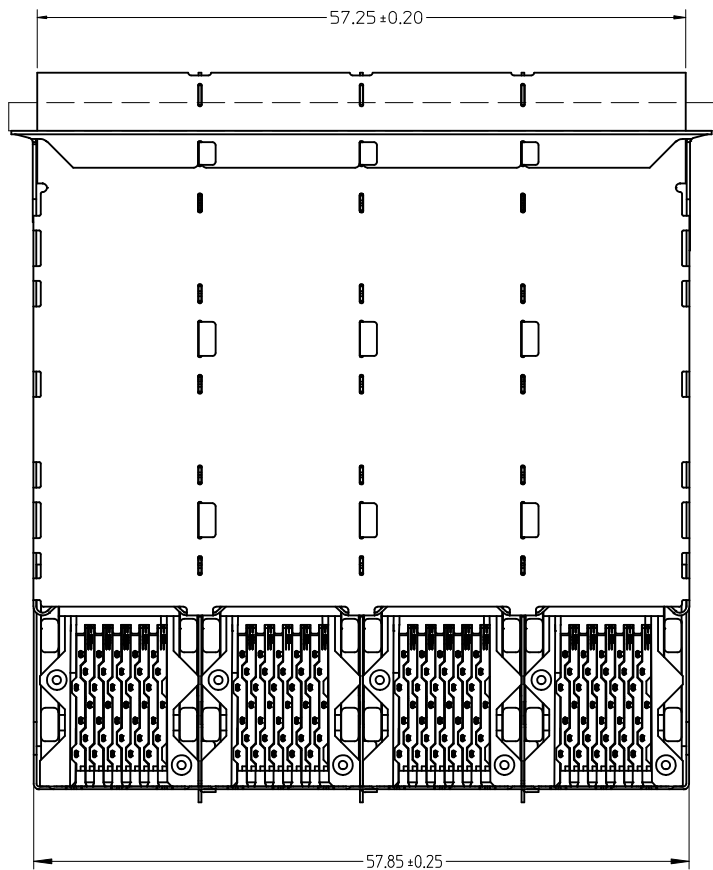

DETAIL B SCALE 6:1
CIRCUIT NUMBERING AND LIGHTPIPE IDENTIFICATION

ADD DETAIL B EC NO: UCP2011-2594 DRWN:WOLFE 2011/02/28 CHKD:BBARKER 2011/02/28 APPR:SMILLER 2011/09/20	QUALITY SYMBOLS ▽=0 ▽=0 ▽=0	GENERAL TOLERANCES (UNLESS SPECIFIED)		DIMENSION STYLE MM ONLY	SCALE 3:1	DESIGN UNITS METRIC	THIRD ANGLE PROJECTION	
		4 PLACES ± --- ± ---	3 PLACES ± --- ± ---	DRAWN BY JLONG	DATE 01-26-2007	STACKED SFP+ 2X4 ASS'Y WITH ELASTOMERIC GASKET AND LIGHTPIPES MOLEX INCORPORATED MATERIAL NO. SD-76092-001 DOCUMENT NO. SD-76092-001 SHEET NO. 2 OF 4		
		2 PLACES ± 0.13 ± ---	1 PLACE ± 0.25 ± ---	CHECKED BY MSANDBERG	DATE 01-26-2007			
		ANGULAR ± 5 °		APPROVED BY RNELSON	DATE 01-26-2007			
DRAFT WHERE APPLICABLE MUST REMAIN WITHIN DIMENSIONS		SEE TABLE	THIS DRAWING CONTAINS INFORMATION THAT IS PROPRIETARY TO MOLEX INCORPORATED AND SHOULD NOT BE USED WITHOUT WRITTEN PERMISSION					

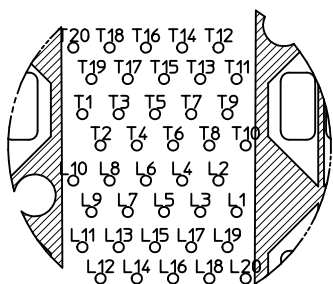

CIRCUIT NUMBERING
COMPONENT SIDE OF BOARD

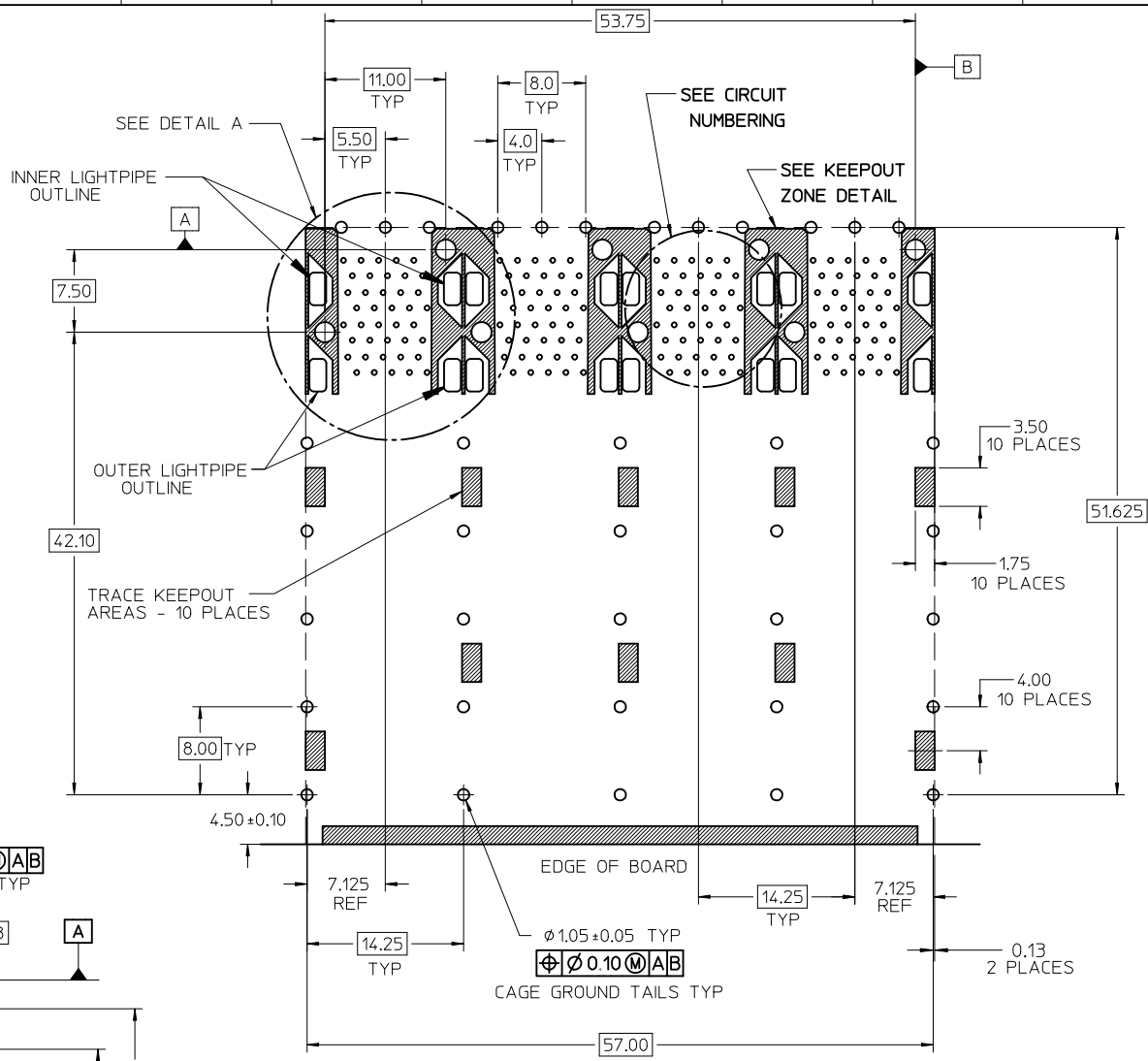

RECOMMENDED PCB LAYOUT - COMPONENT SIDE
MINIMUM PCB THICKNESS OF 1.57MM
THE ENTIRE AREA OF THE CONNECTOR FOOTPRINT
TO BE CONSIDERED THE KEEP OUT AREA INDICATED
BY THE DASHED LINE

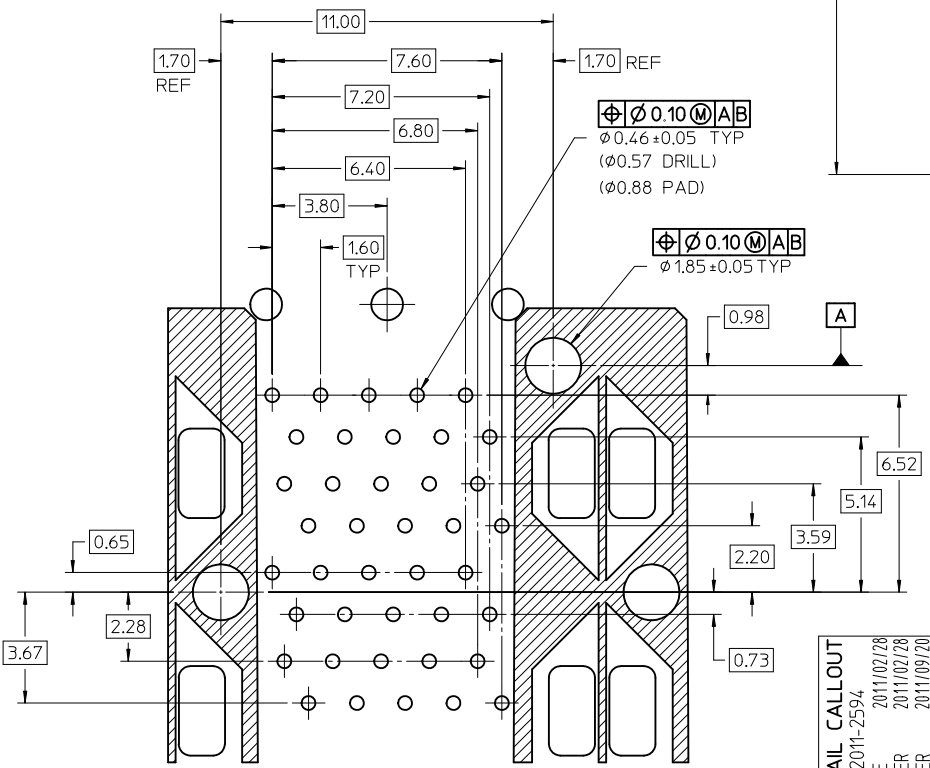

DETAIL A
SCALE 8:1

CHG EC NO: UCP2011-2594 DRAWN: MWOLFE CHKD: BBARKER APPR: SMILLER	2011/02/28	2011/02/28	2011/09/20
	DESCRIPTION		
	REV		

QUALITY SYMBOLS ▽=0 ▽=0 ▽=0	GENERAL TOLERANCES (UNLESS SPECIFIED)	
	mm	INCH
	4 PLACES ± ---	± ---
	3 PLACES ± ---	± ---
	2 PLACES ± 0.13	± ---
	1 PLACE ± 0.25	± ---
	ANGULAR ± 5 °	
DRAFT WHERE APPLICABLE MUST REMAIN WITHIN DIMENSIONS		

DIMENSION STYLE MM ONLY	
DRAWN BY	DATE
JLONG	01-26-2007
CHECKED BY	DATE
MSANDBERG	01-26-2007
APPROVED BY	DATE
RNELSON	01-26-2007
MATERIAL NO.	DOCUMENT NO.
SEE TABLE	SD-76092-001

SCALE 3:1	DESIGN UNITS METRIC	THIRD ANGLE PROJECTION
STACKED SFP+ 2X4 ASS'Y WITH ELASTOMERIC GASKET AND LIGHTPIPES		
MOLEX INCORPORATED		
SHEET NO. 3 OF 4		

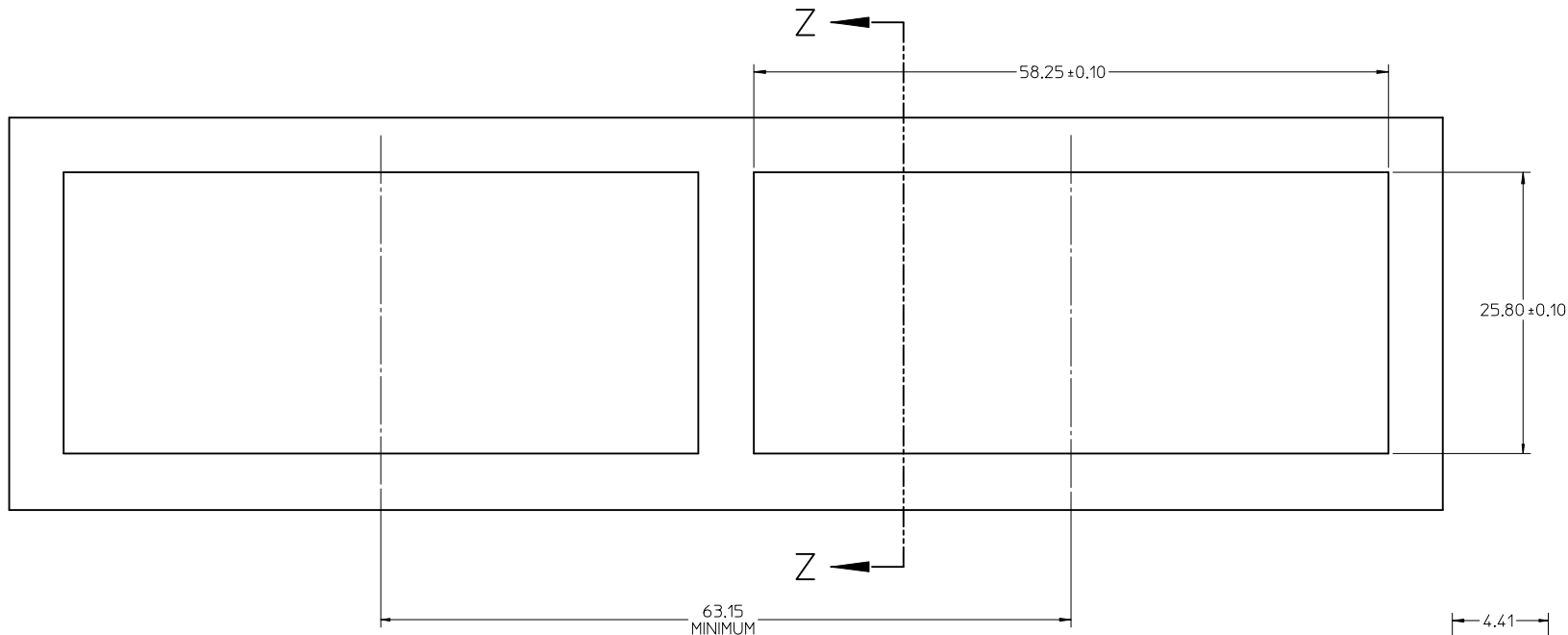

BEZEL CUTOUT CENTER SPACING DETAIL
BEZEL THICKNESS 0.8-2.6

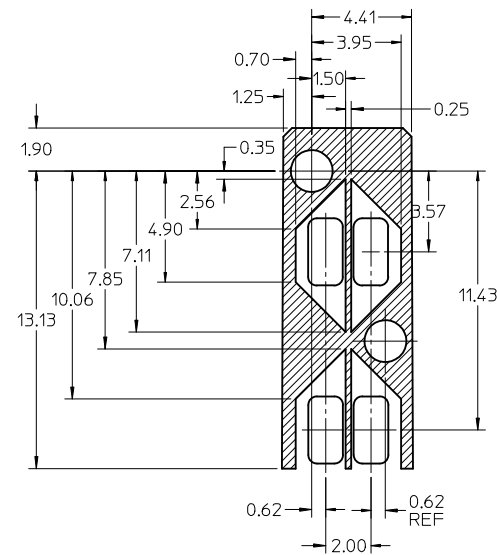
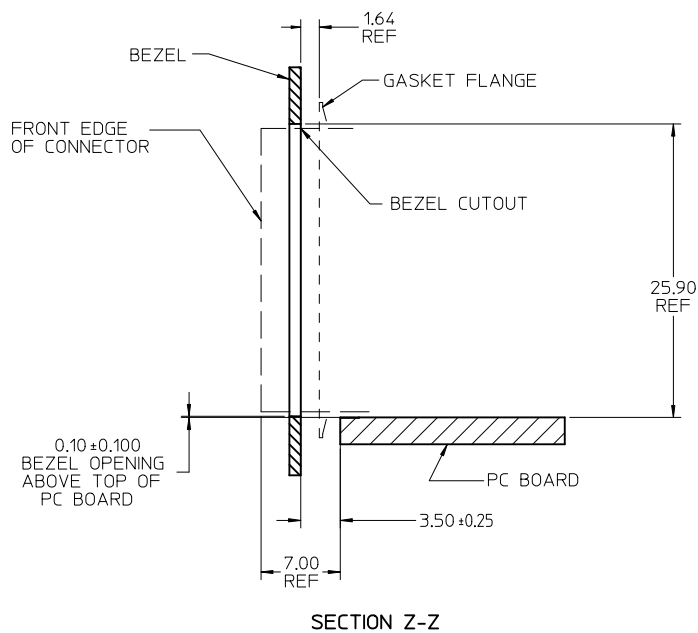

KEEP OUT ZONE DETAIL - LIGHTPIPE LOCATION AND OTHER ZONES
SCALE 6:1

DELETE MIDDLE BEZEL DIM EC NO: UCP2011-2594 DRAWN: WOLFE 2011/02/28 CHKD: BARKER 2011/02/28 APPR: MILLER 2011/09/20	QUALITY SYMBOLS ∇=0 ∇=0 ∇=0	GENERAL TOLERANCES (UNLESS SPECIFIED)		DIMENSION STYLE	SCALE	DESIGN UNITS	THIRD ANGLE PROJECTION	
				MM ONLY	3:1	METRIC		
				DRAWN BY	DATE	TITLE		
				CHECKED BY	DATE	STACKED SFP+ 2X4 ASS'Y WITH ELASTOMERIC GASKET AND LIGHTPIPES		
				APPROVED BY	DATE	MOLEX INCORPORATED		
				RNELSON	01-26-2007	MOLEX INCORPORATED		
		ANGULAR ± 5 °		MATERIAL NO.		DOCUMENT NO.		
		DRAFT WHERE APPLICABLE MUST REMAIN WITHIN DIMENSIONS		SEE TABLE		SD-76092-001		
				SIZE		SHEET NO.		
				C THIS DRAWING CONTAINS INFORMATION THAT IS PROPRIETARY TO MOLEX INCORPORATED AND SHOULD NOT BE USED WITHOUT WRITTEN PERMISSION		4 OF 4		