

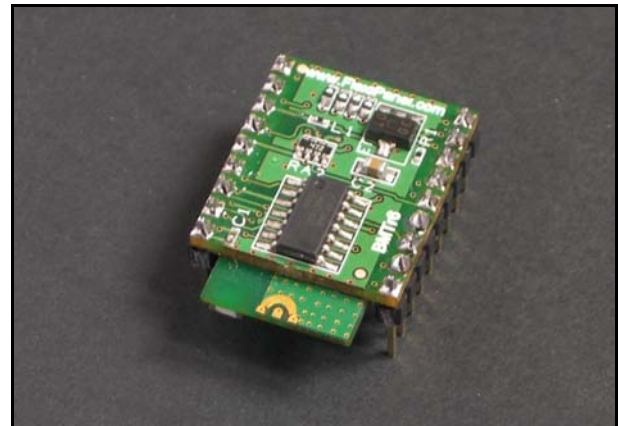

LinkMatik 2.0TM

Bluetooth 2.0 serial / audio transceiver with auto-connect modes and command interface

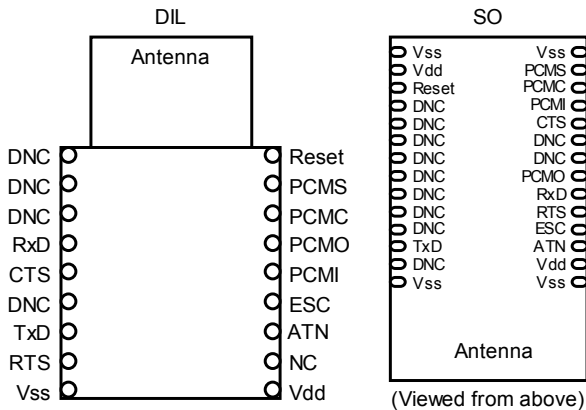

- Auto-Slave and Auto-Master configurations for no-host control, otherwise controlled with simple command set
- Connects with up to 4 slaves (command mode only)
- PCM audio profile (command mode only)
- Bluetooth 2.0 certified
- FCC / CE certified with integral antenna
- End-to-end latency 8-15 ms
- Low power: ~25mA transmitting, 370µA sleep
- Authentication and encryption
- Device discovery
- Sniff, park and hold low power modes
- Hardware flow control or no flow control
- Bluetooth error correction layer
- Class I Bluetooth radio, 100m range
- 3.3-5V supply (DIL), or 3.3V supply (SO)
- Wide range of baud rates up to 230kbaud (serial port only, not over-the-air)

Enquire about related products, including:

- Puck antenna for external mounting
- Audio codec

Summary

LinkMatik 2.0 is a serial / PCM audio to Bluetooth data link. It can be controlled from a host controller using simple commands.

LinkMatik 2.0 can also operate without a host controller for point-to-point serial connections. Auto-Slave and Auto-Master modes allow LinkMatik 2.0 to operate a slave, master or wedded pair. LinkMatik is shipped in Auto-Slave mode.

The module can be interfaced to many standard Bluetooth devices, e.g. Laptop computers, PDA's, Mobile phones etc. PCM (Pulse Code Modulation) audio connections provide an audio interface when used with a suitable audio codec.

LinkMatik 2.0 replaces our earlier LinkMatik and BlueMatik products providing an enhanced feature set, faster data rates and substantially lower power.

Applications

- Direct access to PDA's, Laptops, Mobile Phones etc
- Wireless audio
- Cable replacement
- Process Control
- Robotics

Manufactured to ISO9001:2000



Ordering Information

Part No	Description
LM20-DIL	Class I Bluetooth 2.0 transceiver 18pin Dual in Line package, 3.3V – 5V
LM20-SO	Class I Bluetooth 2.0 transceiver surface mount package, 3.3V

Contents

POWER CONNECTIONS	3	<i>Configuring Bluetooth Device Class</i>	5
RADIO LINK / ANTENNA	3	<i>Set PIN Code Security</i>	5
SERIAL CONNECTIONS	3	<i>Wedded Pairs</i>	6
OPERATING MODES.....	4	<i>Command Mode</i>	6
AUTO-SLAVE MODE.....	4	MIGRATION FROM LINKMATIK 1.0	6
AUTO-MASTER MODE.....	4	MIGRATION FROM BLUEMATIK 1.0	6
COMMAND MODE	4	BLUETOOTH DEVICE CLASSES	7
CONFIGURATION COMMANDS	4	<i>Services and Major Device Class</i>	7
<i>Sending Configuration Commands</i>	4	<i>Minor device class</i>	7
<i>Configuring Auto-Slave Mode</i>	5	<i>Example</i>	8
<i>Configuring Auto-Master Mode</i>	5	MECHANICAL DATA.....	9
<i>Setting the Baud Rate</i>	5	TECHNICAL SPECIFICATIONS	10
<i>Configuring the Bluetooth Name</i>	5		

Pin Connections

Pin Name	Description
ATN	Attention output: In Auto-Slave and Auto-Master modes, output is high if connected, low if unconnected. In command mode, output is high if serial data on RxD is from a remote device, low if a command mode response. (note 1)
ESC	Escape input: A low to high transition causes the module to revert to the mode where it accepts commands rather than transmits transparent data. (note 1)
CTS	Clear To Send: Flow control input to <i>LinkMatik 2.0</i> . When low, <i>LinkMatik 2.0</i> will output data on the TxD line. (note 1)
DNC	Do not connect
NC	Not connected
PCMC	3.3V PCM audio clock. (note 2)
PCMI	3.3V PCM audio input. (note 2)
PCMO	3.3V PCM audio output. (note2)
PCMS	3.3V PCM audio sync. (note 2)
Reset	Reset – Low to operate, high for at least 10ms to reset. (note 1, 3)
RTS	Flow control output from <i>LinkMatik 2.0</i> . When high, do not send data to <i>LinkMatik 2.0</i> . (note 1)
RxD	Serial data input to <i>LinkMatik 2.0</i> . (note 1)
TxD	Serial data output from <i>LinkMatik 2.0</i> . (note 1)
Vss	Power ground reference.
Vdd	3.3V - 5V power supply (DIL version) 3.3V power supply (SO version)

1. Vdd logic. Output highs are Vdd. Input high must not exceed Vdd.
2. 3.3V logic. Output highs are 3.3V. Input high must not exceed 3.3V.
3. DIL module has pull-down resistor and this pin may be left unconnected.

Power Connections

The DIL module contains all necessary power supply filtering components.

The SO module should have a 100nF decoupling capacitor placed between each of the two Vdd pins and their adjacent Vss pin, close to the module. In addition, a series inductor capable of choking 2.54GHz (approx 10nH) should be placed between the power supply and Vdd. The recommended part is muRata LQW15AN10NJ00.

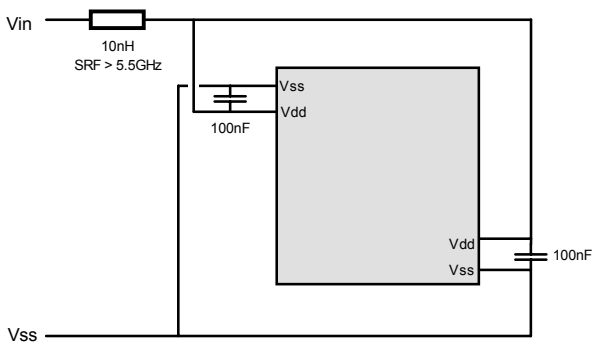

Figure 2. Power supply filtering

Radio Link / Antenna

The radio is a 2.4GHz Class I Bluetooth device with an integral antenna. To achieve 100m range, the corresponding Bluetooth device must also be Class I.

There should be no PCB copper or components within 2cm of the antenna.

Note that the use of an external antenna is not recommended due to coax losses and requirements for recertification.

If an external antenna is required because the product is to be housed in a metal enclosure, enquire about our puck antenna housings. These enclose the entire module and permit it to be externally mounted.

If an external antenna is required to achieve directional gain, enquire about our dish antenna housing. This encloses the entire module at the focus of a parabolic dish for directional operation.

Serial Connections

The serial data default baud rate is 9600 baud standard active low format with 8 data bits, no parity bit and 1 stop bit. Hardware flow control is

supported. If no flow control is required, RTS should be connected to CTS.

CTS and RTS can only be used for flow control. Since data is buffered inside the Bluetooth module, the RTS and CTS signals are locally generated and do not necessarily correspond to the state of the RTS and CTS lines at the other end of the link.

In Auto-Slave and Auto-Master modes, if no connection is indicated on the ATN output, any data on the RxD pin will be interpreted as a command. If the device connected to LinkMatik cannot suppress serial data when there is no connection, the ATN output should be used to clamp the RxD pin high when the device is not connected. An example clamping circuit is shown in figure 3a. (Simpler logic circuits would work, but this circuit uses of the same IC as fig 3b.)

To convert RxD and TxD and, if required, CTS and RTS, to RS232 levels, a level shifter such as a MAX232 may be used.

To convert the serial data lines RxD and TxD to RS485 signals, an RS485 transceiver such as a MAX 3082 may be used. This requires a device enable (DE) signal whenever the TxD output is active. A suitable monostable circuit to generate DE from TxD is shown in figure 3b.

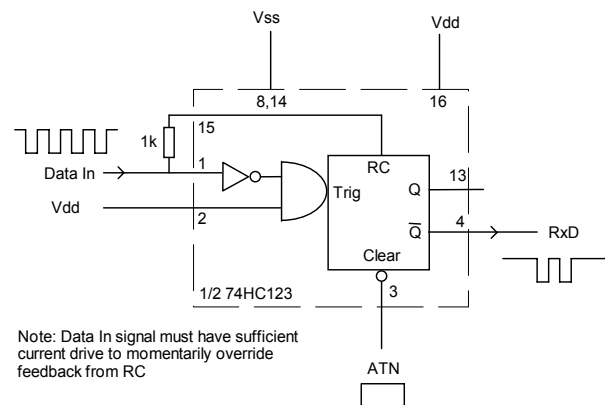

Note: Data In signal must have sufficient current drive to momentarily override feedback from RC

Figure 3a. RxD Clamping

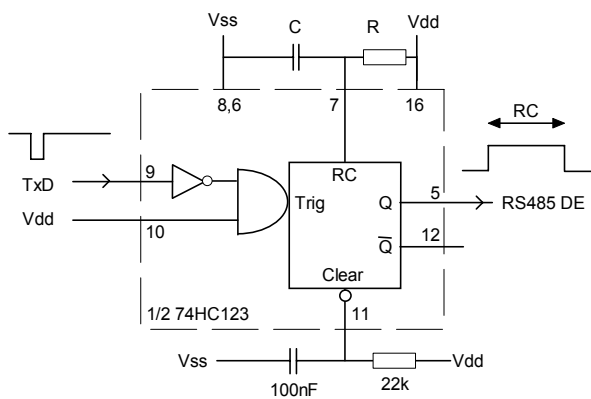

$$\text{For } C = 100\text{nF} \quad R = \frac{250000}{\text{Baud}} \text{ (K}\Omega\text{)}$$

e.g. for 9600 baud, $R \sim 27\text{K}$

Figure 3b. RS485 driver enable

Operating Modes

There are three operating modes for LinkMatik 2.0:

- Auto-Slave Mode, where LinkMatik 2.0 allows other devices to connect to it.
- Auto-Master Mode, where LinkMatik 2.0 tries to connect to devices it is paired with.
- Command Mode, where LinkMatik accepts instructions from the host. Command mode is also used for:
 - Configuring Auto-Slave and Auto-Master settings such as baud rates
 - Audio modes
 - Connections to multiple devices

LinkMatik is shipped in Auto-Slave mode with the PIN code 0000 (four zeroes).

Auto-Slave Mode

In Auto-Slave mode, LinkMatik 2.0 waits for a remote device to discover and connect to it. No commands are required, and, unless configuration commands are sent, no responses are generated except data from the remote device.

The ESC input would normally be tied low in Auto-Slave mode unless configuration commands were to be sent to LinkMatik 2.0.

The ATN output indicates whether the module is in a connected state. The ATN output will be set high when a connection is complete and low when there is no connection. If data is sent while the ATN is low, it will be interpreted as a command.

Auto-Master Mode

In Auto-Master mode, LinkMatik 2.0 searches for any device it has in its list of paired devices and connects to the first one it finds. A slave and a master can thus be wedded and require no host control. No commands are required, and, unless configuration commands are sent, no responses are generated except data from the remote device.

The ESC input would normally be tied low in Auto-Master mode unless configuration commands were to be sent to LinkMatik 2.0.

The ATN output indicates whether the module is in a connected state. The ATN output will be set high when a connection is complete and low when there is no connection. If data is sent while the ATN is low, it will be interpreted as a command.

Command Mode

In Command mode, commands are sent to LinkMatik to control it. Only those commands required to configure Auto-Slave and Auto-Master modes are detailed in this document.

Refer to the LinkMatik 2.0 Command Reference DS389-1 for complete details about other commands available in command mode, including audio mode commands.

Configuration Commands

Sending Configuration Commands

To send commands for configuration purposes (as opposed to host control), connect LinkMatik to a serial terminal emulator such as Windows HyperTerminal. Commands should be terminated with carriage return and linefeed characters.

If required, FlexiPanel's Pixie Config Tool can be used to convert between USB and TTL serial signals in order to make the connections. If used to connect to the SO module, however, care should be taken to clamp the TxD maximum voltage to 3.3V using a circuit such as shown in figure 4. The tool has no flow control, so CTS is connected to RTS.

To ensure all commands take effect, reset LinkMatik 2.0.

To see a list of all current settings, send the following command:

```
SET
```

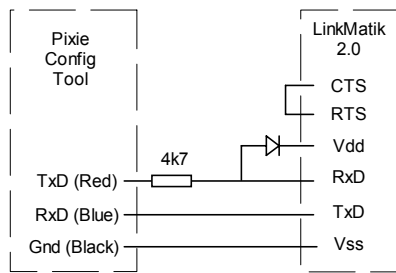

Figure 4 - Interfacing to Pixie Config Tool

Configuring Auto-Slave Mode

To configure LinkMatik for Auto-Slave mode, send the following commands:

```
SET CONTROL AUTOCALL
SET CONTROL ECHO 0
SET CONTROL CD 4 0
SET BT PAGEMODE 4 2000 1
```

Configuring Auto-Master Mode

The following commands are used to set up Auto-Master mode:

```
SET CONTROL AUTOCALL 1101
SET CONTROL ECHO 0
SET CONTROL CD 4 0
SET BT PAGEMODE 0 2000 1
```

In Auto-Master mode, LinkMatik searches for a device it is already paired with and connects to it. If more than one device is paired, LinkMatik will connect to the first paired device it detects and is able to connect to.

Therefore the LinkMatik must be paired with the devices it should connect to. You can do this by pairing from the remote device. Alternatively you can use commands to discover the remote device and pair with it. This is detailed in the Wedded Pairs section.

Setting the Baud Rate

Format: SET CONTROL BAUD RATE,8PS

Example: SET CONTROL BAUD 9600,8N1

Response: (none)

This command sets the RxD / TxD baud rate. *There must be no spaces between the arguments.* The baud rate change takes effect immediately. The baud rate must be changed with care. If you set it incorrectly by accident, you may no longer be able to communicate with LinkMatik.

Only 8 bit data is permitted, with or without parity; however, 7-bit data with odd or even parity may be transmitted as 8-bit, no parity. Note that baud rates below 9600 baud are somewhat inaccurate.

RATE 1200 = 1200 baud (+1.73% error)
 2400 = 2400 baud (+1.73% error)
 4800 = 4800 baud (+1.73% error)
 9600 = 19200 baud (-0.82% error)
 19200 = 9600 baud (+0.45% error)
 38400 = 38400 baud (-0.18% error)
 57600 = 57600 baud (+0.03% error)
 76800 = 76800 baud (+0.14% error)
 115200 = 115200 baud (+0.03% error)
 230400 = 230400 baud (+0.03% error)

P N = no parity bit

E = even parity bit

O = odd parity bit

S 1 = one stop bit

2 = 2 stop bits

Although setting higher baud rates than 230400 baud is permitted, this is not recommended since it is greater than can be achieved over-the-air. Additionally, once the baud rate has been changed to a higher level, it is not possible to revert it without successfully communicating at the higher baud rate, which some customers have experienced difficulty in doing.

Configuring the Bluetooth Name

Format: SET BT NAME DEVNAME

Example: SET BT NAME "Fred"

Response: (none)

This command sets the Bluetooth device name. The name can be up to 256 ASCII characters long, but not all remote devices will be able to display that many.

Configuring Bluetooth Device Class

Format: SET BT CLASS DEVCLS

Example: SET BT CLASS 522204

Response: (none)

This command sets the Bluetooth device class represented as a 6-digit hexadecimal (3-byte) number. Device classes are detailed in the section Bluetooth Device Classes.

Set PIN Code Security

Format: SET BT AUTH * [PIN]

Example: SET BT AUTH * 0000

Response: (none)

This command sets the PIN code security settings. If the optional PIN argument is specified, this becomes the pin code used to pair with other devices.

If the optional `PIN` argument is not specified, security and PIN codes are disabled. This is not recommended as some devices require PIN codes and connection will therefore not be possible.

The PIN code may be up to 16 characters long. Note that many mobile phones can only specify the digits 0-9 as PIN codes.

Wedded Pairs

To create a wedded pair, one device must be the master and the other the slave. Set the same PIN code on both devices. Then place the first device in Auto-Slave mode.

Place the second device in Auto-Master mode. It will have nothing paired with it initially. To set up its pair, use the `I` command to scan for the slave device.

Example: `I 8 N`

Response example:

```
INQUIRY_PARTIAL 01:23:45:67:89:AB DEVCLS
INQUIRY 1
INQUIRY BTADDR DEVCLS "" RSSI
NAME BTADDR DEVNAME
```

When the inquiry command is complete, connect to the Auto-Slave device using the `C` command, referring to the Bluetooth address reported in the `INQUIRY` response obtained during the scan.

Format: `C BTADDR 1101 RFC`

Example: `C 01:23:45:67:89:AB 1101 RFC`

Response: `CALL LINKID`
`CONNECT LINKID RFCOMM`

The devices will now be paired. When both devices power up, they will connect together automatically

Command Mode

To configure LinkMatik for Command / Data mode, send the following commands:

```
SET CONTROL AUTOCALL
SET CONTROL ECHO 4
SET CONTROL CD 4 1
SET BT PAGEMODE 3 2000 1
```

Migration from LinkMatik 1.0

Migration from LinkMatik 1.0 should be relatively straightforward. The following issues must be considered:

- The MSM pin is replaced with the ESC pin which should be kept low except to switch to command mode.

- ATN pin performs the same function as the earlier Status pin outputting high when the device is connected.
- Data should not be sent to LinkMatik when ATN is low; it will be interpreted as a command
- Connect / Sleep pin is no longer functional. Sleep mode can only be entered from command mode.
- Auto-Master Mode connects according to its list of paired devices rather than the name of the remote device.

Migration from BlueMatik 1.0

Migration from BlueMatik 1.0 is possible but will require modification of the motherboard and host firmware. The following issues must be considered:

- Pin-out substantially changed
- Command set substantially changed.

Bluetooth Device Classes

The 3-byte Bluetooth device class determines what the module claims to be when other Bluetooth devices ask it. It affects the icon that appears on other Bluetooth devices and may affect the device discovery function. In particular some mobile phones only look for certain sub classes, e.g. headsets.

The device class consists of three elements: the services available, the major device class and the minor device class. Any number of services can be indicated, but exactly one Major Class must be specified. The minor device class is an optional addition, defining a subset of the major device class.

Services and Major Device Class

The first two bytes of the device class contain the services information and the major device class. They are calculated by adding together as many service byte values that are required and one Major Device Class.

Byte 1	Byte 2	Description	Data Type
0x00	0x20	Limited discovery mode	Services
0x01	0x00	Positioning	
0x02	0x00	Network	
0x04	0x00	Rendering	
0x08	0x00	Capturing	
0x10	0x00	Object transfer	
0x20	0x00	Audio	
0x40	0x00	Telephony	
0x80	0x00	Information	
0x00	0x01	Computer	Device Major Class
0x00	0x02	Phone	
0x00	0x03	LAN	
0x00	0x04	AV	
0x00	0x05	Peripheral	
0x00	0x06	Imaging	
0x00	0x1F	Uncategorized	
0x00	0x00	Miscellaneous Device Class	

Minor device class

The last byte defines the minor device class and is optional. Its interpretation depends on the major device class specified as follows.

Byte 3	Computer Major Class	Phone Major Class	LAN Major Class	AV Major Class
0x00	Other	Other	LAN 0% utilized	Other
0x04	Desktop	Cellphone		Wearable headset
0x08	Server	Cordless phone		Hands free device
0x0C	Laptop	Smartphone		
0x10	Handheld	Gateway / modem		Microphone
0x14	Palm-sized	ISDN		Loudspeaker
0x18	Wearable			Headphones
0x1C				Walkman
0x20			LAN 1-17% utilized	Car audio
0x24				Set top box
0x28				Hi-Fi
0x2C				VCR
0x30				Video camera
0x34				Camcorder
0x38				Monitor
0x3C				Monitor with audio
0x40			LAN 17-33% utilized	Conferencing device
0x48				Toy
0x60			LAN 33-50% utilized	
0x80			LAN 50-67% utilized	
0xA0			LAN 67-83% utilized	
0xC0			LAN 83-99% utilized	
0xE0			LAN 100% utilized	

Byte 3	Peripheral Device Class <i>Add together one † value and one ‡ value</i>	Imaging Device Class <i>Add together as many values as apply</i>	Uncategorized / Miscellaneous Device Class
0x00	No keyboard or pointing device †		Uncategorized / Miscellaneous
0x00	Other ‡		
0x04	Joystick		
0x08	Gamepad ‡		
0x0C	Remote control ‡		
0x10	Sensing device ‡	Display	
0x14	Digitizer ‡		
0x18	Card reader‡		
0x1C			
0x20		Camera	
0x40	Keyboard but no pointing device †	Scanner	
0x80	Pointing device but no keyboard †	Printer	
0xC0	Keyboard and pointing device †		

Example

A cellphone might have Object Transfer, Telephony, Network and Limited Discovery services. Its major class would be Phone and its minor class would be Cellphone. The calculation of the device class is as follows:

Byte 1	Byte 2	Byte 3	Notes
10			Object Transfer services
40			Telephony services
02			Network services
	20		Limited Discovery services
	02		Phone Major class
		04	Cellphone minor class
52	22	04	Total = 522204 = Cellphone device class

This device class is the default when shipped. All values shown are hexadecimal.

Mechanical Data

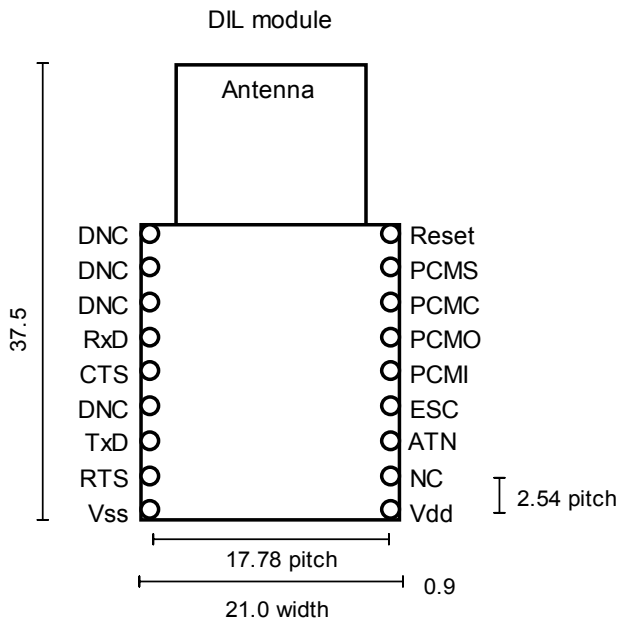

Pins are formed pin type,
1mm dia hole required on PCB pad

All dimensions mm

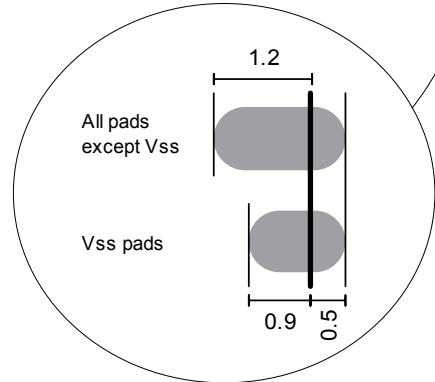
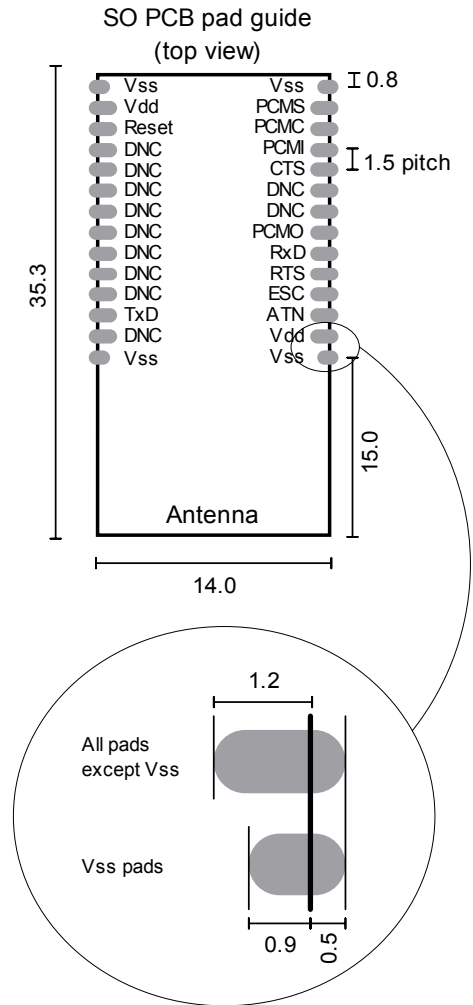

Note: Aries brand ZIF sockets will accept LinkMatik 2.0 DIL. (e.g. Farnell p/n 1169111, Digi-Key p/n A309-ND)

Technical Specifications

Max operating temperature	-40°C to +85 °C
Max storage temperature	-40°C to +105 °C
Dimensions L × W × H (DIL)	37.5mm × 19.5mm × 6.5mm excluding pins
Dimensions L × W × H (SO Class I)	35.5mm × 14mm × 2.3mm

Electrical

Supply Voltage (DIL) Vdd	3.2V to 5.1V
Supply Voltage (SO) Vdd	3.2V to 3.4V
Average current, Idle	3mA
Average current, Idle, Deep Sleep on	1.5mA
Average current, Idle, Deep Sleep on, not connectable, not visible	370µA
Average current, during discovery and connecting	55mA
Average current, connected as slave	6.5mA
Average current, connected as master	21.5mA
Average current, connected as slave, sniff mode	3.7mA
Average current, connected as master, sniff mode	4.85mA
Average current, connected as slave, park mode	3.4mA
Average current, connected, transmitting	22mA
Average current, connected, receiving	33.4mA
Average current, connected, transmitting, sniff mode	18.3mA
Average current, connected, receiving, sniff mode	23.8mA
Max voltage on I/O pins (DIL)	-0.4V to 3.4V (PCM audio pins) -0.4V to Vdd+0.1V (other pins)
Max voltage on I/O pins (SO)	-0.4V to 3.4V

Radio

Max RF output power	Class I = 100mW = +20dBm
RF frequency range	2402MHz to 2480MHz
RF channels	79
Frequency hopping	1600 Hz
Range	100m nominal
Communication latency, serial to serial via two LinkMatik 2.0 radios	8ms to 15ms

Bluetooth qualification & logos and trademarks

The radio has been pre-qualified and is listed in the Bluetooth Qualified Products as B03005. FlexiPanel Ltd is registered as an Adopter Member with the Bluetooth SIG, Inc. OEMs wishing to re-brand FlexiPanel Ltd Bluetooth products and use the Bluetooth Logos and trademarks must also register as Adopter Members. Membership is free, refer to www.bluetooth.org for details.

FCC and CE modular approval

The radio has 'modular approval' for USA and certain European countries, provided the existing integral antenna is used. The module indicates that it does not require further R&TTE certification. The exterior of the product should be marked as follows:

Contains Transmitter Module FCC ID: QOQWT11

Distributor Contact Details

LinkMatik 2.0 is assembled and distributed by agreement by RF Solutions Ltd:



RF Solutions Ltd
Unit 21, Cliffe Industrial Estate,
Lewes, E. Sussex, BN8 6JL, United Kingdom
email : sales@rfsolutions.co.uk
<http://www.rfsolutions.co.uk>
Tel: +44 (0)1273 898 000, Fax: +44 (0)1273 480 661

Manufacturer Contact Details

LinkMatik 2.0 was developed by FlexiPanel Ltd:



FlexiPanel Ltd
2 Marshall St, 3rd Floor
London W1F 9BB, United Kingdom
<http://www.flexipanel.com>
email: support@flexipanel.com

Mouser Electronics

Authorized Distributor

Click to View Pricing, Inventory, Delivery & Lifecycle Information:

[FlexiPanel:](#)

[LM20-SO](#) [LM20-DIL](#)